



**THE DATASHEET OF
CY62128ELL-45ZAXI**



Features

- Very high speed: 45 ns
- Temperature ranges
 - Industrial: -40 °C to +85 °C
 - Automotive-A: -40 °C to +85 °C
 - Automotive-E: -40 °C to +125 °C
- Voltage range: 4.5 V to 5.5 V
- Pin compatible with CY62128B
- Ultra low standby power
 - Typical standby current: 1 μA
 - Maximum standby current: 4 μA (Industrial)
- Ultra low active power
 - Typical active current: 1.3 mA at f = 1 MHz
- Easy memory expansion with \overline{CE}_1 , CE_2 , and \overline{OE} features
- Automatic power down when deselected
- Complementary metal oxide semiconductor (CMOS) for optimum speed and power
- Offered in standard Pb-free 32-pin STSOP, 32-pin SOIC, and 32-pin thin small outline package (TSOP) Type I packages

Functional Description

The CY62128E is a high performance CMOS static RAM organized as 128K words by 8 bits. This device features advanced circuit design to provide ultra low active current. This is ideal for providing More Battery Life™ (MoBL®) in portable applications. The device also has an automatic power down feature that significantly reduces power consumption when addresses are not toggling. Placing the device into standby mode reduces power consumption by more than 99 percent when deselected (\overline{CE}_1 HIGH or CE_2 LOW). The eight input and output pins (I/O₀ through I/O₇) are placed in a high impedance state when the device is deselected (\overline{CE}_1 HIGH or CE_2 LOW), the outputs are disabled (\overline{OE} HIGH), or a write operation is in progress (CE_1 LOW and CE_2 HIGH and \overline{WE} LOW).

To write to the device, take Chip Enable (\overline{CE}_1 LOW and CE_2 HIGH) and Write Enable (\overline{WE}) inputs LOW. Data on the eight I/O pins (I/O₀ through I/O₇) is then written into the location specified on the address pins (A₀ through A₁₆).

To read from the device, take Chip Enable (\overline{CE}_1 LOW and CE_2 HIGH) and Output Enable (\overline{OE}) LOW while forcing Write Enable (\overline{WE}) HIGH. Under these conditions, the contents of the memory location specified by the address pins appear on the I/O pins.

The CY62128E device is suitable for interfacing with processors that have TTL I/P levels. It is not suitable for processors that require CMOS I/P levels. Please see [Electrical Characteristics on page 5](#) for more details and suggested alternatives.

For a complete list of related resources, [click here](#).

Logic Block Diagram

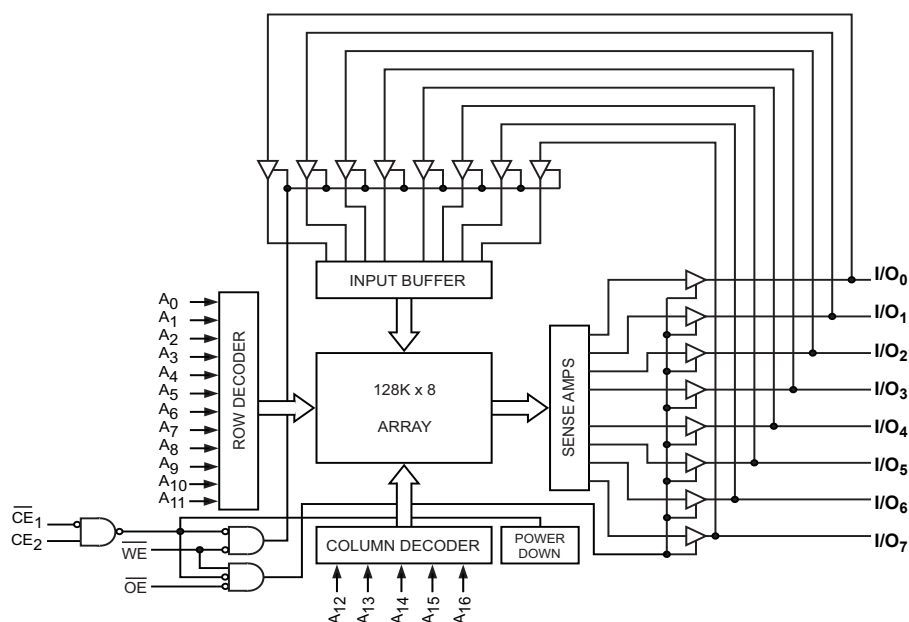

Contents

Pin Configuration	3	Ordering Information	13
Product Portfolio	4	Ordering Code Definitions	13
Maximum Ratings	5	Package Diagrams	14
Operating Range	5	Acronyms	17
Electrical Characteristics	5	Document Conventions	17
Capacitance	6	Units of Measure	17
Thermal Resistance	6	Document History Page	18
AC Test Loads and Waveforms	6	Sales, Solutions, and Legal Information	20
Data Retention Characteristics	7	Worldwide Sales and Design Support	20
Data Retention Waveform	7	Products	20
Switching Characteristics	8	PSoC® Solutions	20
Switching Waveforms	9	Cypress Developer Community	20
Truth Table	12	Technical Support	20

Pin Configuration

Figure 1. 32-pin STSOP pinout [1]

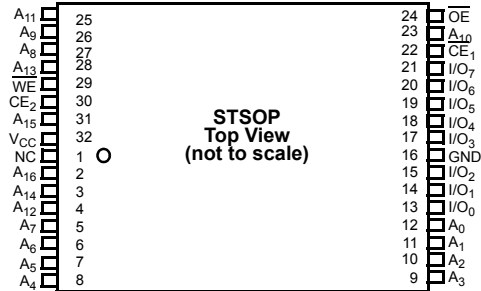

Figure 2. 32-pin TSOP I pinout [1]

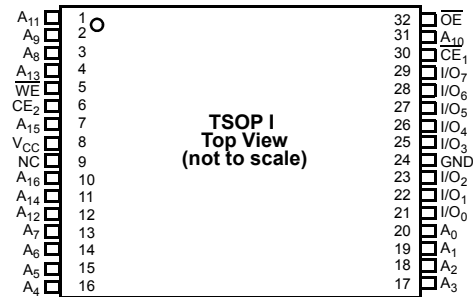
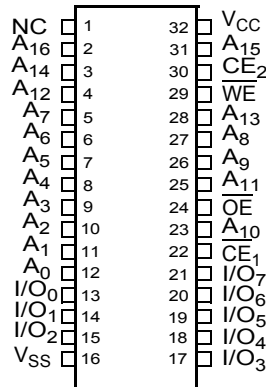

Figure 3. 32-pin SOIC pinout [1]

Top View



Note

1. NC pins are not connected on the die.

Product Portfolio

Product	Range	V _{CC} Range (V)			Speed (ns)	Power Dissipation					
						Operating I _{CC} (mA)				Standby I _{SB2} (μA)	
		f = 1MHz		f = f _{max}							
		Typ ^[2]	Max	Typ ^[2]		Max	Typ ^[2]	Max			
CY62128ELL	Industrial / Automotive-A	4.5	5.0	5.5	45 ^[3]	1.3	2	11	16	1	4
CY62128ELL	Automotive-E	4.5	5.0	5.5	55	1.3	4	11	35	1	30

Notes

- Typical values are included for reference only and are not guaranteed or tested. Typical values are measured at V_{CC} = V_{CC(typ)}, T_A = 25 °C.
- When used with a 100 pF capacitive load and resistive loads as shown on page 4, access times of 55 ns (t_{AA}, t_{ACE}) and 25 ns (t_{DOE}) are guaranteed.

Maximum Ratings

Exceeding maximum ratings may shorten the useful life of the device. User guidelines are not tested.

Storage temperature -65 °C to +150 °C

Ambient temperature
with power applied -55 °C to +125 °C

Supply voltage
to ground potential [4, 5] ... -0.5 V to 6.0 V ($V_{CC(max)}$ + 0.5 V)

DC voltage applied to outputs
in High Z State [4, 5] -0.5 V to 6.0 V ($V_{CC(max)}$ + 0.5 V)

DC input voltage [4, 5] -0.5 V to 6.0 V ($V_{CC(max)}$ + 0.5 V)

Output current into outputs (LOW) 20 mA

Static discharge voltage
(MIL-STD-883, Method 3015) > 2001 V

Latch up current > 200 mA

Operating Range

Device	Range	Ambient Temperature	V_{CC} [6]
CY62128ELL	Industrial / Automotive-A	-40 °C to +85 °C	4.5 V to 5.5 V
	Automotive-E	-40 °C to +125 °C	

Electrical Characteristics

Over the Operating Range

Parameter	Description	Test Conditions	45 ns (Industrial/ Automotive-A)			55 ns (Automotive-E)			Unit
			Min	Typ [7]	Max	Min	Typ [7]	Max	
V_{OH}	Output HIGH voltage	$V_{CC} = 4.5\text{ V}$ $I_{OH} = -1\text{ mA}$	2.4	-	-	2.4	-	-	V
		$V_{CC} = 5.5\text{ V}$ $I_{OH} = -0.1\text{ mA}$	-	-	3.4 [8]	-	-	3.4 [8]	
V_{OL}	Output LOW voltage	$I_{OL} = 2.1\text{ mA}$	-	-	0.4	-	-	0.4	V
V_{IH}	Input HIGH voltage	$V_{CC} = 4.5\text{ V to } 5.5\text{ V}$	2.2	-	$V_{CC} + 0.5$	2.2	-	$V_{CC} + 0.5$	V
V_{IL}	Input LOW voltage	$V_{CC} = 4.5\text{ V to } 5.5\text{ V}$	-0.5	-	0.8	-0.5	-	0.8	V
I_{IX}	Input leakage current	$GND \leq V_I \leq V_{CC}$	-1	-	+1	-4	-	+4	μA
I_{OZ}	Output leakage current	$GND \leq V_O \leq V_{CC}$, Output Disabled	-1	-	+1	-4	-	+4	μA
I_{CC}	V_{CC} Operating supply current	$f = f_{max} = 1/t_{RC}$ $V_{CC} = V_{CC(max)}$	-	11	16	-	11	35	mA
		$f = 1\text{ MHz}$ $I_{OUT} = 0\text{ mA}$ CMOS levels	-	1.3	2	-	1.3	4	
I_{SB2} [9]	Automatic CE power-down Current—CMOS inputs	$\overline{CE}_1 \geq V_{CC} - 0.2\text{ V}$ or $CE_2 \leq 0.2\text{ V}$, $V_{IN} \geq V_{CC} - 0.2\text{ V}$ or $V_{IN} \leq 0.2\text{ V}$, $f = 0$, $V_{CC} = V_{CC(max)}$	-	1	4	-	1	30	μA

Notes

- $V_{IL(min)}$ = -2.0 V for pulse durations less than 20 ns.
- $V_{IH(max)}$ = $V_{CC} + 0.75\text{ V}$ for pulse durations less than 20 ns.
- Full device AC operation assumes a 100 μs ramp time from 0 to $V_{CC(min)}$ and 200 μs wait time after V_{CC} stabilization.
- Typical values are included for reference only and are not guaranteed or tested. Typical values are measured at $V_{CC} = V_{CC(typ)}$, $T_A = 25\text{ }^\circ\text{C}$.
- Please note that the maximum V_{OH} limit does not exceed minimum CMOS V_{IH} of 3.5 V. If you are interfacing this SRAM with 5 V legacy processors that require a minimum V_{IH} of 3.5 V, please refer to Application Note AN6081 for technical details and options you may consider.
- Only chip enables (\overline{CE}_1 and CE_2) must be at CMOS level to meet the I_{SB2} / I_{CCDR} spec. Other inputs can be left floating.

Capacitance

Parameter ^[10]	Description	Test Conditions	Max	Unit
C _{IN}	Input capacitance	T _A = 25 °C, f = 1 MHz, V _{CC} = V _{CC(typ)}	10	pF
C _{OUT}	Output capacitance		10	pF

Thermal Resistance

Parameter ^[10]	Description	Test Conditions	32-pin SOIC Package	32-pin STSOP Package	32-pin TSOP Package	Unit
Θ _{JA}	Thermal resistance (junction to ambient)	Still Air, soldered on a 3 × 4.5 inch, two-layer printed circuit board	48.67	32.56	33.01	°C/W
Θ _{JC}	Thermal resistance (junction to case)		25.86	3.59	3.42	°C/W

AC Test Loads and Waveforms

Figure 4. AC Test Loads and Waveforms

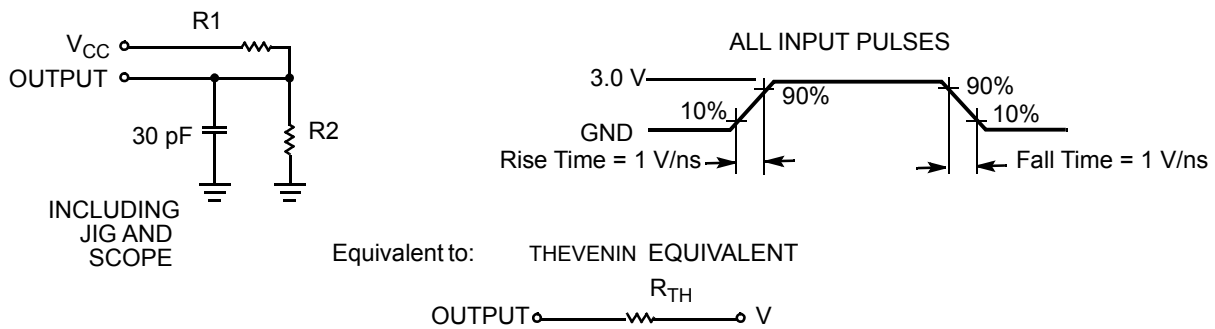

Parameters	Value	Unit
R1	1800	Ω
R2	990	Ω
R _{TH}	639	Ω
V _{TH}	1.77	V

Note

10. Tested initially and after any design or process changes that may affect these parameters.

Data Retention Characteristics

Over the Operating Range

Parameter	Description	Conditions	Min	Typ ^[11]	Max	Unit	
V_{DR}	V_{CC} for data retention		2	–	–	V	
I_{CCDR} ^[12]	Data retention current	$V_{CC} = V_{DR}$, $\overline{CE}_1 \geq V_{CC} - 0.2 \text{ V}$ or $CE_2 \leq 0.2 \text{ V}$, $V_{IN} \geq V_{CC} - 0.2 \text{ V}$ or $V_{IN} \leq 0.2 \text{ V}$	Industrial / Automotive-A	–	–	4	μA
			Automotive-E	–	–	30	μA
t_{CDR} ^[13]	Chip deselect to data retention time		0	–	–	ns	
t_R ^[14]	Operation recovery time		CY62128ELL-45	45	–	–	ns
			CY62128ELL-55	55	–	–	

Data Retention Waveform

Figure 5. Data Retention Waveform ^[15]

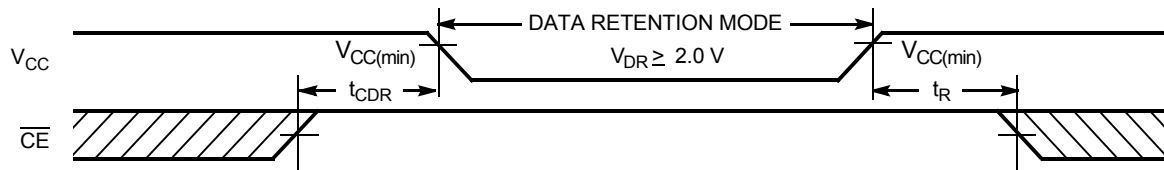

Notes

11. Typical values are included for reference only and are not guaranteed or tested. Typical values are measured at $V_{CC} = V_{CC(yp)}$, $T_A = 25^\circ\text{C}$.
12. Only chip enables (\overline{CE}_1 and CE_2) must be at CMOS level to meet the I_{SBZ} / I_{CCDR} spec. Other inputs can be left floating.
13. Tested initially and after any design or process changes that may affect these parameters.
14. Full device AC operation requires linear V_{CC} ramp from V_{DR} to $V_{CC(min)} > 100 \mu\text{s}$ or stable at $V_{CC(min)} > 100 \mu\text{s}$.
15. \overline{CE} is the logical combination of \overline{CE}_1 and CE_2 . When \overline{CE}_1 is LOW and CE_2 is HIGH, \overline{CE} is LOW; when \overline{CE}_1 is HIGH or CE_2 is LOW, \overline{CE} is HIGH.

Switching Characteristics

Over the Operating Range

Parameter ^[16]	Description	45 ns (Industrial / Automotive-A)		55 ns (Automotive-E)		Unit
		Min	Max	Min	Max	
Read Cycle						
t _{RC}	Read cycle time	45	–	55	–	ns
t _{AA}	Address to data valid	–	45	–	55	ns
t _{OHA}	Data hold from address change	10	–	10	–	ns
t _{ACE}	\overline{CE}_1 LOW and CE ₂ HIGH to data valid	–	45	–	55	ns
t _{DOE}	\overline{OE} LOW to data valid	–	22	–	25	ns
t _{LZOE}	\overline{OE} LOW to Low Z ^[17]	5	–	5	–	ns
t _{HZOE}	\overline{OE} HIGH to High Z ^[17, 18]	–	18	–	20	ns
t _{LZCE}	\overline{CE}_1 LOW and CE ₂ HIGH to Low Z ^[17]	10	–	10	–	ns
t _{HZCE}	\overline{CE}_1 HIGH or CE ₂ LOW to High Z ^[17, 18]	–	18	–	20	ns
t _{PU}	\overline{CE}_1 LOW and CE ₂ HIGH to power-up	0	–	0	–	ns
t _{PD}	\overline{CE}_1 HIGH or CE ₂ LOW to power-down	–	45	–	55	ns
Write Cycle ^[19, 20]						
t _{WC}	Write cycle time	45	–	55	–	ns
t _{SCE}	\overline{CE}_1 LOW and CE ₂ HIGH to write end	35	–	40	–	ns
t _{AW}	Address setup to write end	35	–	40	–	ns
t _{HA}	Address hold from write end	0	–	0	–	ns
t _{SA}	Address setup to write start	0	–	0	–	ns
t _{PWE}	\overline{WE} pulse width	35	–	40	–	ns
t _{SD}	Data setup to write end	25	–	25	–	ns
t _{HD}	Data hold from write end	0	–	0	–	ns
t _{HZWE}	\overline{WE} LOW to High Z ^[17, 18]	–	18	–	20	ns
t _{LZWE}	\overline{WE} HIGH to Low Z ^[17]	10	–	10	–	ns

Notes

16. Test conditions for all parameters other than tri-state parameters assume signal transition time of 3 ns (1 V/ns) or less, timing reference levels of 1.5 V, input pulse levels of 0 to 3 V, and output loading of the specified I_{OL}/I_{OH} as shown in the [Figure 4 on page 6](#).

17. At any given temperature and voltage condition, t_{HZCE} is less than t_{LZCE}, t_{HZOE} is less than t_{LZOE}, and t_{HZWE} is less than t_{LZWE} for any given device.

18. t_{HZOE}, t_{HZCE}, and t_{HZWE} transitions are measured when the outputs enter a high impedance state.

19. The internal Write time of the memory is defined by the overlap of \overline{WE} , CE = V_{IL}. All signals must be ACTIVE to initiate a write and any of these signals can terminate a write by going INACTIVE. The data input setup and hold timing must be referenced to the edge of the signal that terminates the write.

20. The minimum write cycle pulse width for Write Cycle No. 3 (\overline{WE} Controlled, \overline{OE} LOW) should be equal to sum of t_{SD} and t_{HZWE}.

Switching Waveforms

Figure 6. Read Cycle 1 (Address Transition Controlled) [21, 22]

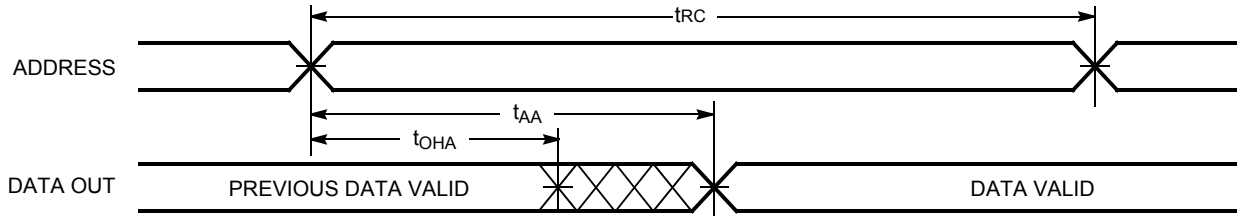
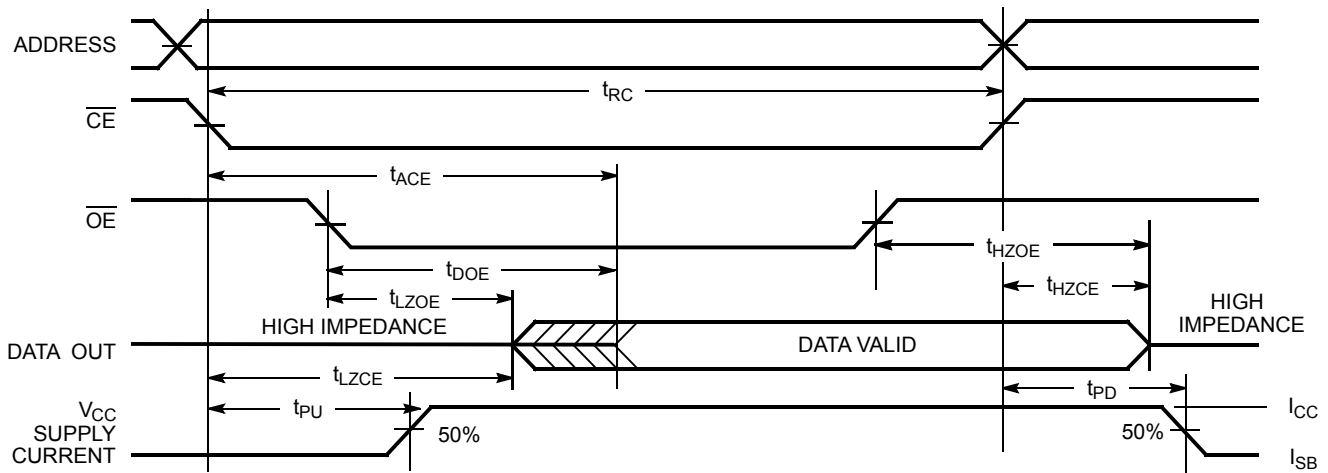

Figure 7. Read Cycle No. 2 (\overline{OE} Controlled) [22, 23, 24]



Notes

21. The device is continuously selected. \overline{OE} , $\overline{CE}_1 = V_{IL}$, $CE_2 = V_{IH}$.

22. \overline{WE} is HIGH for read cycle.

23. Address valid before or similar to \overline{CE}_1 transition LOW and CE_2 transition HIGH.

24. \overline{CE} is the logical combination of \overline{CE}_1 and CE_2 . When \overline{CE}_1 is LOW and CE_2 is HIGH, \overline{CE} is LOW; when \overline{CE}_1 is HIGH or CE_2 is LOW, \overline{CE} is HIGH.

Switching Waveforms (continued)

Figure 8. Write Cycle No. 1 (\overline{WE} Controlled) [25, 26, 27, 28]

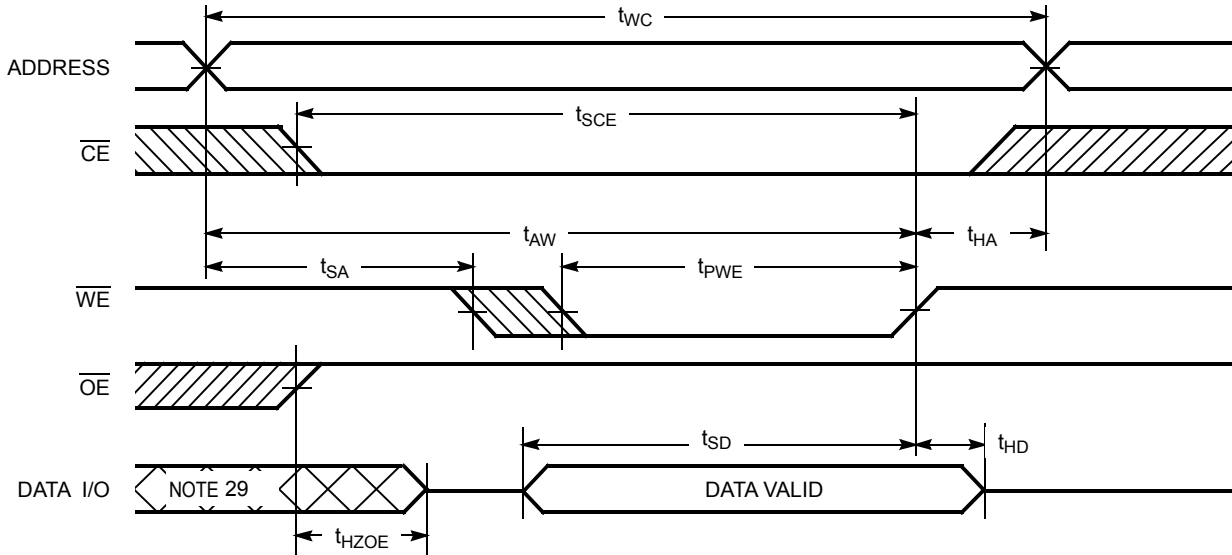

Notes

- 25. \overline{CE} is the logical combination of \overline{CE}_1 and CE_2 . When \overline{CE}_1 is LOW and CE_2 is HIGH, \overline{CE} is LOW; when \overline{CE}_1 is HIGH or CE_2 is LOW, \overline{CE} is HIGH.
- 26. The internal Write time of the memory is defined by the overlap of \overline{WE} , $\overline{CE} = V_{IL}$. All signals must be ACTIVE to initiate a write and any of these signals can terminate a write by going INACTIVE. The data input setup and hold timing must be referenced to the edge of the signal that terminates the write.
- 27. Data I/O is high impedance if $\overline{OE} = V_{IH}$.
- 28. If \overline{CE}_1 goes HIGH or CE_2 goes LOW simultaneously with \overline{WE} HIGH, the output remains in high impedance state.
- 29. During this period, the I/Os are in output state and input signals must not be applied.

Switching Waveforms (continued)

Figure 9. Write Cycle No. 2 (\overline{CE}_1 or CE_2 Controlled) [30, 31, 32, 33]

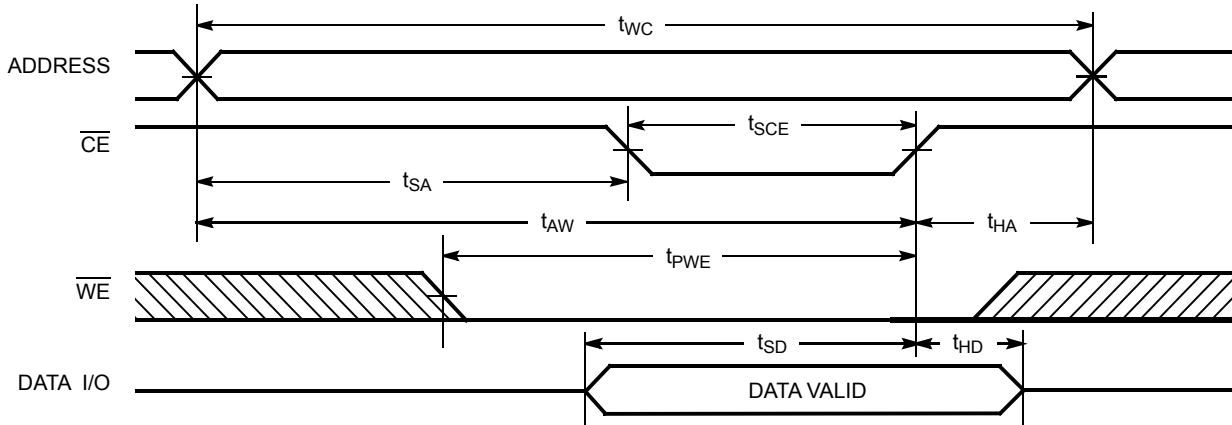
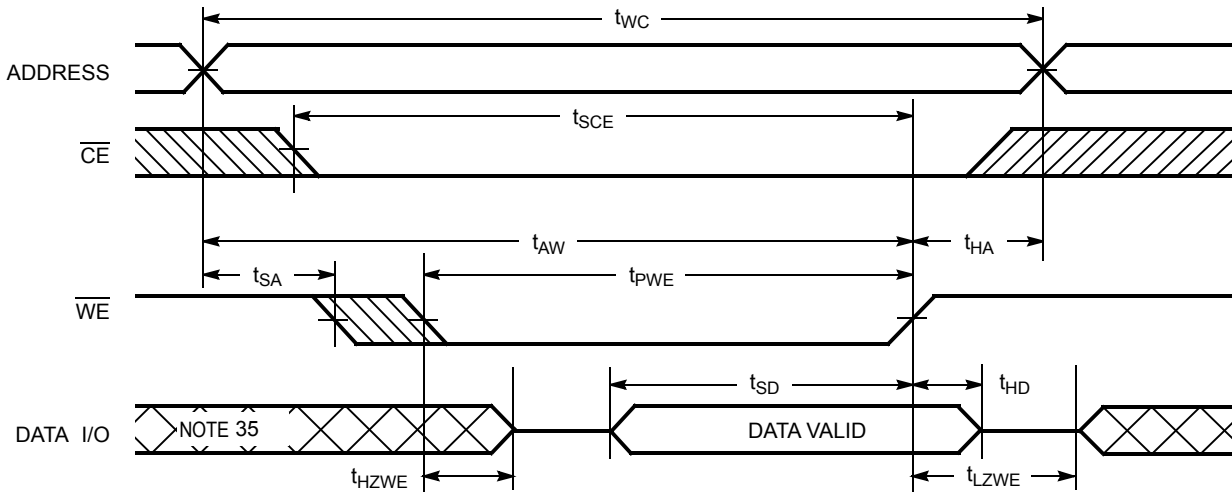

Figure 10. Write Cycle No. 3 (\overline{WE} Controlled, \overline{OE} LOW) [30, 33, 34]



Notes

- 30. \overline{CE} is the logical combination of \overline{CE}_1 and CE_2 . When \overline{CE}_1 is LOW and CE_2 is HIGH, \overline{CE} is LOW; when \overline{CE}_1 is HIGH or CE_2 is LOW, \overline{CE} is HIGH.
- 31. The internal Write time of the memory is defined by the overlap of \overline{WE} , $\overline{CE} = V_{IL}$. All signals must be ACTIVE to initiate a write and any of these signals can terminate a write by going INACTIVE. The data input setup and hold timing must be referenced to the edge of the signal that terminates the write.
- 32. Data I/O is high impedance if $\overline{OE} = V_{IH}$.
- 33. If \overline{CE}_1 goes HIGH or CE_2 goes LOW simultaneously with \overline{WE} HIGH, the output remains in high impedance state.
- 34. The minimum write cycle pulse width should be equal to sum of t_{SD} and t_{HZWE} .
- 35. During this period, the I/Os are in output state and input signals must not be applied.

Truth Table

\overline{CE}_1	CE_2	\overline{WE}	\overline{OE}	Inputs/Outputs	Mode	Power
H	X ^[36]	X	X	High Z	Deselect/Power down	Standby (I_{SB})
X ^[36]	L	X	X	High Z	Deselect/Power down	Standby (I_{SB})
L	H	H	L	Data Out	Read	Active (I_{CC})
L	H	L	X	Data In	Write	Active (I_{CC})
L	H	H	H	High Z	Selected, outputs disabled	Active (I_{CC})

Note

36. The 'X' (Don't care) state for the Chip enables in the truth table refer to the logic state (either HIGH or LOW). Intermediate voltage levels on these pins is not permitted.

Ordering Information

Speed (ns)	Ordering Code	Package Diagram	Package Type	Operating Range
45	CY62128ELL-45SXI	51-85081	32-pin 450-Mil SOIC (Pb-free)	Industrial
	CY62128ELL-45ZAXI	51-85094	32-pin STSOP (Pb-free)	
	CY62128ELL-45ZXI	51-85056	32-pin TSOP Type I (Pb-free)	
	CY62128ELL-45SXA	51-85081	32-pin 450-Mil SOIC (Pb-free)	Automotive-A
	CY62128ELL-45ZXA	51-85056	32-pin TSOP Type I (Pb-free)	
55	CY62128ELL-55SXE	51-85081	32-pin 450-Mil SOIC (Pb-free)	Automotive-E
	CY62128ELL-55ZAXE	51-85094	32-pin STSOP (Pb-free)	

Contact your local Cypress sales representative for availability of these parts.

Ordering Code Definitions

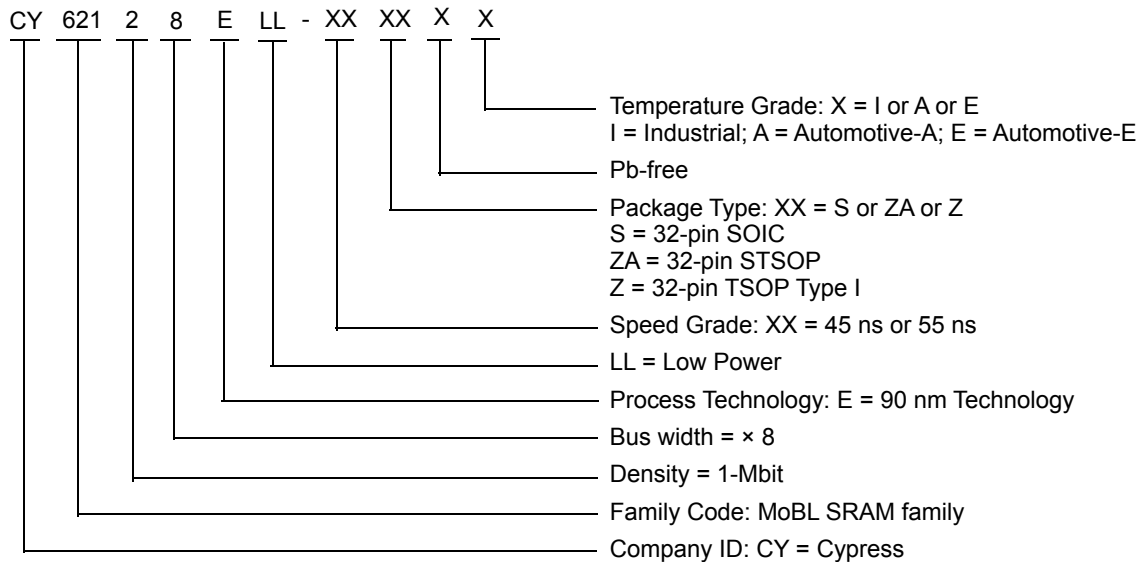

Package Diagrams

Figure 11. 32-pin Molded SOIC (450 Mil) S32.45/SZ32.45 Package Outline, 51-85081

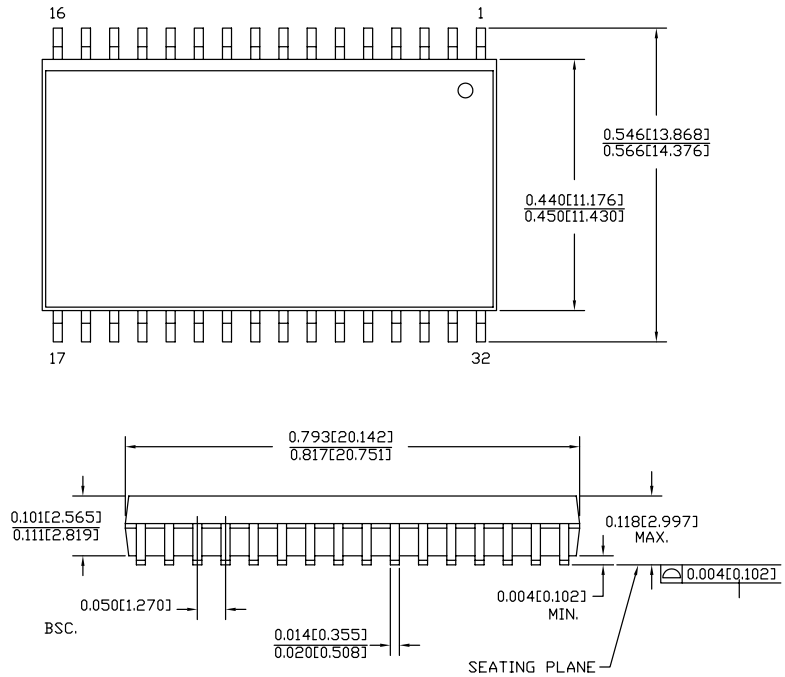

DIMENSIONS IN INCHES(MM) ^{MIN.}
MAX.

PACKAGE WEIGHT: See Cypress Package Material Declaration Datasheet (PMDD) posted on the Cypress web.

PART #	
S32.45	STANDARD PKG.
SZ32.45	LEAD FREE PKG.

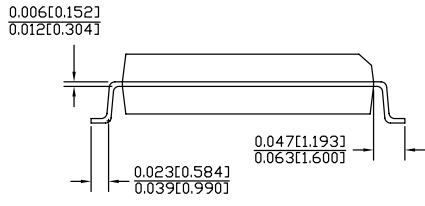

51-85081 *E

Package Diagrams (continued)

Figure 12. 32-pin Small TSOP (8 × 13.4 × 1.2 mm) ZA32 Package Outline, 51-85094

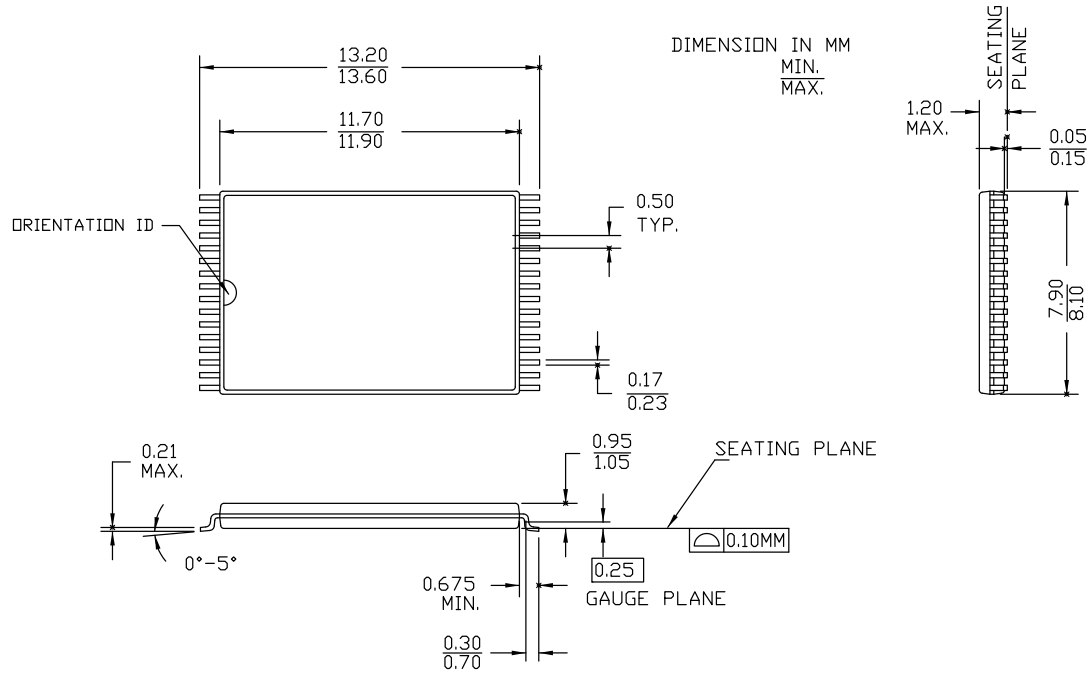

51-85094 *G

Package Diagrams (continued)

Figure 13. 32-pin TSOP I (8 × 20 × 1.0 mm) Z32R Package Outline, 51-85056

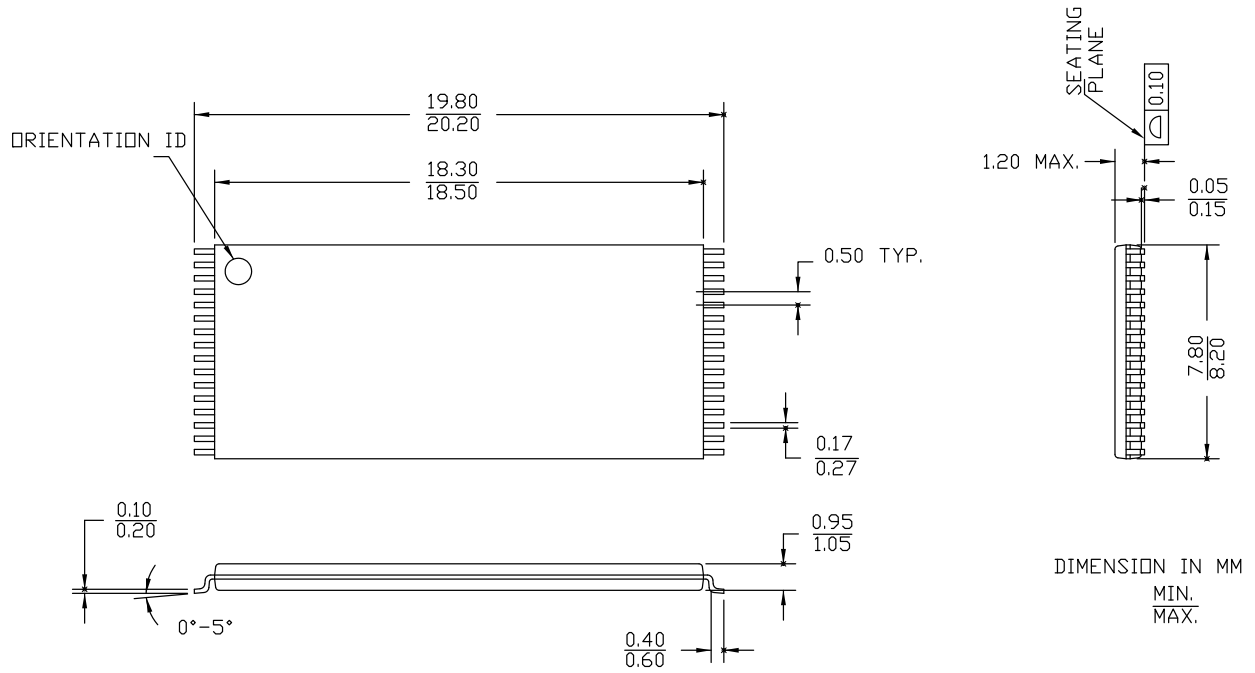

51-85056 *G

Acronyms

Acronym	Description
\overline{CE}	Chip Enable
CMOS	Complementary Metal Oxide Semiconductor
I/O	Input/Output
\overline{OE}	Output Enable
SRAM	Static Random Access Memory
SOIC	Small Outline Integrated Circuit
STSOP	Small Thin Small Outline Package
TSOP	Thin Small Outline Package
\overline{WE}	Write Enable

Document Conventions

Units of Measure

Symbol	Unit of Measure
°C	degree Celsius
MHz	megahertz
μA	microampere
μs	microsecond
mA	milliampere
mm	millimeter
ns	nanosecond
Ω	ohm
%	percent
pF	picofarad
V	volt
W	watt

Document History Page

Document Title: CY62128E MoBL®, 1-Mbit (128 K × 8) Static RAM				
Document Number: 38-05485				
Rev.	ECN No.	Submission Date	Orig. of Change	Description of Change
**	203120	See ECN	AJU	New data sheet
*A	299472	See ECN	SYT	Converted from Advance Information to Preliminary Changed t_{OHA} from 6 ns to 10 ns for both 35 ns and 45 ns, respectively Changed t_{DOE} from 15 ns to 18 ns for 35 ns speed bin Changed t_{HZOE} , t_{HZWE} from 12 and 15 ns to 15 and 18 ns for the 35 and 45 ns speed bins, respectively Changed t_{HZCE} from 12 and 15 ns to 18 and 22 ns for the 35 and 45 ns speed bins, respectively Changed t_{SCE} from 25 and 40 ns to 30 and 35 ns for the 35 and 45 ns speed bins, respectively Changed t_{SD} from 15 and 20 ns to 18 and 22 ns for the 35 and 45 ns speed bins, respectively Added Pb-free package information Added footnote #9 Changed operating range for SOIC package from Commercial to Industrial Modified signal transition time from 5 ns to 3 ns in footnote #11 Changed max of I_{SB1} , I_{SB2} and I_{CCDR} from 1.0 μ A to 1.5 μ A
*B	461631	See ECN	NXR	Converted from Preliminary to Final Included Automotive Range and 55 ns speed bin Removed 35 ns speed bin Removed "L" version of CY62128E Removed Reverse TSOP I package from Product offering Changed $I_{CC(Typ)}$ from 8 mA to 11 mA and $I_{CC(max)}$ from 12 mA to 16 mA for $f = f_{max}$ Changed $I_{CC(max)}$ from 1.5 mA to 2.0 mA for $f = 1$ MHz Removed I_{SB1} DC Specs from Electrical characteristics table Changed $I_{SB2(max)}$ from 1.5 μ A to 4 μ A Changed $I_{SB2(Typ)}$ from 0.5 μ A to 1 μ A Changed $I_{CCDR(max)}$ from 1.5 μ A to 4 μ A Changed the AC Test load Capacitance value from 100 pF to 30 pF Changed t_{LZOE} from 3 to 5 ns Changed t_{LZCE} from 6 to 10 ns Changed t_{HZCE} from 22 to 18 ns Changed t_{PWE} from 30 to 35 ns Changed t_{SD} from 22 to 25 ns Changed t_{LZWE} from 6 to 10 ns Updated the Ordering Information Table
*C	464721	See ECN	NXR	Updated the Block Diagram on page # 1
*D	563144	See ECN	AJU	Added footnote 4 on page 2
*E	1024520	See ECN	VKN	Added Automotive-A information Converted Automotive-E specs to final Added footnote #9 related to I_{SB2} and I_{CCDR} Updated Ordering Information table
*F	2548575	08/05/08	NXR	Corrected typo error in Ordering Information table
*G	2934396	06/03/10	VKN	Added footnote #22 related to chip enable Updated package diagrams Updated template
*H	3113780	12/17/2010	PRAS	Updated Logic Block Diagram. Added Ordering Code Definitions.

Document History Page (continued)

Document Title: CY62128E MoBL®, 1-Mbit (128 K × 8) Static RAM Document Number: 38-05485				
Rev.	ECN No.	Submission Date	Orig. of Change	Description of Change
*I	3223635	04/12/2011	RAME	Removed V30 value from Ordering Code Definition. Updated Package diagram 51-85056 from *E to *F and 51-85094 *E to *F Added Acronyms and Units of Measure. Updated to new template.
*J	3292276	06/24/2011	RAME	Updated Data Retention Characteristics (Changed the conditions and minimum value of t_R parameter). Updated to new template.
*K	4018425	06/03/2013	MEMJ	Updated Functional Description . Updated Electrical Characteristics : Added one more Test Condition " $V_{CC} = 5.5\text{ V}$, $I_{OH} = -0.1\text{ mA}$ " for V_{OH} parameter and added maximum value corresponding to that Test Condition. Added Note 8 and referred the same note in maximum value for V_{OH} parameter corresponding to Test Condition " $V_{CC} = 5.5\text{ V}$, $I_{OH} = -0.1\text{ mA}$ ". Updated Package Diagrams : spec 51-85081 – Changed revision from *C to *E. Completing Sunset Review.
*L	4410948	06/17/2014	VINI	Updated Switching Characteristics : Added Note 20 and referred the same note in "Write Cycle". Updated Switching Waveforms : Added Note 34 and referred the same note in Figure 10 . Updated Package Diagrams : spec 51-85094 – Changed revision from *F to *G. spec 51-85056 – Changed revision from *F to *G. Updated to new template. Completing Sunset Review.
*M	4478332	08/19/2014	BMAH	Updated Truth Table : Fixed typo (Replaced WE with \overline{WE} and OE with \overline{OE} in the header row).
*N	4581542	11/27/2014	VINI	Updated Functional Description : Added "For a complete list of related resources, click here ." at the end. Updated Maximum Ratings : Referred Notes 4, 5 in "Supply voltage to ground potential".
*O	4797476	06/15/2015	VINI	Updated to new template. Completing Sunset Review.
*P	5726469	05/04/2017	AESATMP7	Updated Cypress Logo and Copyright.

Sales, Solutions, and Legal Information

Worldwide Sales and Design Support

Cypress maintains a worldwide network of offices, solution centers, manufacturer's representatives, and distributors. To find the office closest to you, visit us at [Cypress Locations](#).

Products

Automotive	cypress.com/go/automotive
Clocks & Buffers	cypress.com/go/clocks
Interface	cypress.com/go/interface
Lighting & Power Control	cypress.com/go/powerpsoc
Memory	cypress.com/go/memory
PSoC	cypress.com/go/psoc
Touch Sensing	cypress.com/go/touch
USB Controllers	cypress.com/go/USB
Wireless/RF	cypress.com/go/wireless

PSoC® Solutions

[psoc.cypress.com/solutions](#)
[PSoC 1](#) | [PSoC 3](#) | [PSoC 4](#) | [PSoC 5LP](#) | [PSoC 6](#)

Cypress Developer Community

[Community](#) | [Forums](#) | [Blogs](#) | [Video](#) | [Training](#)

Technical Support

[cypress.com/go/support](#)

© Cypress Semiconductor Corporation, 2004-2017. This document is the property of Cypress Semiconductor Corporation and its subsidiaries, including Spansion LLC ("Cypress"). This document, including any software or firmware included or referenced in this document ("Software"), is owned by Cypress under the intellectual property laws and treaties of the United States and other countries worldwide. Cypress reserves all rights under such laws and treaties and does not, except as specifically stated in this paragraph, grant any license under its patents, copyrights, trademarks, or other intellectual property rights. If the Software is not accompanied by a license agreement and you do not otherwise have a written agreement with Cypress governing the use of the Software, then Cypress hereby grants you a personal, non-exclusive, nontransferable license (without the right to sublicense) (1) under its copyright rights in the Software (a) for Software provided in source code form, to modify and reproduce the Software solely for use with Cypress hardware products, only internally within your organization, and (b) to distribute the Software in binary code form externally to end users (either directly or indirectly through resellers and distributors), solely for use on Cypress hardware product units, and (2) under those claims of Cypress's patents that are infringed by the Software (as provided by Cypress, unmodified) to make, use, distribute, and import the Software solely for use with Cypress hardware products. Any other use, reproduction, modification, translation, or compilation of the Software is prohibited.

TO THE EXTENT PERMITTED BY APPLICABLE LAW, CYPRESS MAKES NO WARRANTY OF ANY KIND, EXPRESS OR IMPLIED, WITH REGARD TO THIS DOCUMENT OR ANY SOFTWARE OR ACCOMPANYING HARDWARE, INCLUDING, BUT NOT LIMITED TO, THE IMPLIED WARRANTIES OF MERCHANTABILITY AND FITNESS FOR A PARTICULAR PURPOSE. To the extent permitted by applicable law, Cypress reserves the right to make changes to this document without further notice. Cypress does not assume any liability arising out of the application or use of any product or circuit described in this document. Any information provided in this document, including any sample design information or programming code, is provided only for reference purposes. It is the responsibility of the user of this document to properly design, program, and test the functionality and safety of any application made of this information and any resulting product. Cypress products are not designed, intended, or authorized for use as critical components in systems designed or intended for the operation of weapons, weapons systems, nuclear installations, life-support devices or systems, other medical devices or systems (including resuscitation equipment and surgical implants), pollution control or hazardous substances management, or other uses where the failure of the device or system could cause personal injury, death, or property damage ("Unintended Uses"). A critical component is any component of a device or system whose failure to perform can be reasonably expected to cause the failure of the device or system, or to affect its safety or effectiveness. Cypress is not liable, in whole or in part, and you shall and hereby do release Cypress from any claim, damage, or other liability arising from or related to all Unintended Uses of Cypress products. You shall indemnify and hold Cypress harmless from and against all claims, costs, damages, and other liabilities, including claims for personal injury or death, arising from or related to any Unintended Uses of Cypress products.

Cypress, the Cypress logo, Spansion, the Spansion logo, and combinations thereof, WICED, PSoC, CapSense, EZ-USB, F-RAM, and Traveo are trademarks or registered trademarks of Cypress in the United States and other countries. For a more complete list of Cypress trademarks, visit [cypress.com](#). Other names and brands may be claimed as property of their respective owners.

Looking for pricing, stock, or lifecycle information?

Click below to explore more details on WIN SOURCE:

- [View CY62128ELL-45ZAXI on WIN SOURCE](#)
- [Cypress Semiconductor Corp Information](#)

Optimize Your Supply Chain with WIN SOURCE Solutions

- ✓ Global Sourcing Solution
- ✓ Obsolete Management
- ✓ Cost Control Management
- ✓ Shortage Management
- ✓ Alternative Solution
- ✓ Excess Inventory Management