



**THE DATASHEET OF
CY62128BLL-70ZXI**



128K x 8 Static RAM

Features

- **Temperature Ranges**
 - Commercial: 0°C to 70°C
 - Industrial: -40°C to 85°C
 - Automotive: -40°C to 125°C
- **4.5V – 5.5V operation**
- **CMOS for optimum speed/power**
- **Low active power**
(70 ns, LL version, Commercial, Industrial)
 - 82.5 mW (max.) (15 mA)
- **Low standby power**
(70 ns, LL version, Commercial, Industrial)
 - 110 μW (max.) (15 μA)
- **Automatic power-down when deselected**
- **TTL-compatible inputs and outputs**
- **Easy memory expansion with \overline{CE}_1 , CE_2 , and \overline{OE} options**

Functional Description^[1]

The CY62128B is a high-performance CMOS static RAM organized as 131,072 words by 8 bits. Easy memory expansion is provided by an active LOW Chip Enable (\overline{CE}_1), an active HIGH Chip Enable (CE_2), an active LOW Output Enable (\overline{OE}), and three-state drivers. This device has an automatic power-down feature that reduces power consumption by more than 75% when deselected.

Writing to the device is accomplished by taking Chip Enable One (\overline{CE}_1) and Write Enable (\overline{WE}) inputs LOW and Chip Enable Two (CE_2) input HIGH. Data on the eight I/O pins (I/O_0 through I/O_7) is then written into the location specified on the address pins (A_0 through A_{16}).

Reading from the device is accomplished by taking Chip Enable One (\overline{CE}_1) and Output Enable (\overline{OE}) LOW while forcing Write Enable (\overline{WE}) and Chip Enable Two (CE_2) HIGH. Under these conditions, the contents of the memory location specified by the address pins will appear on the I/O pins.

The eight input/output pins (I/O_0 through I/O_7) are placed in a high-impedance state when the device is deselected (\overline{CE}_1 HIGH or CE_2 LOW), the outputs are disabled (\overline{OE} HIGH), or during a write operation (\overline{CE}_1 LOW, CE_2 HIGH, and \overline{WE} LOW).

The CY62128B is available in a standard 450-mil-wide SOIC, 32-pin TSOP type I and STSOP packages.

Logic Block Diagram

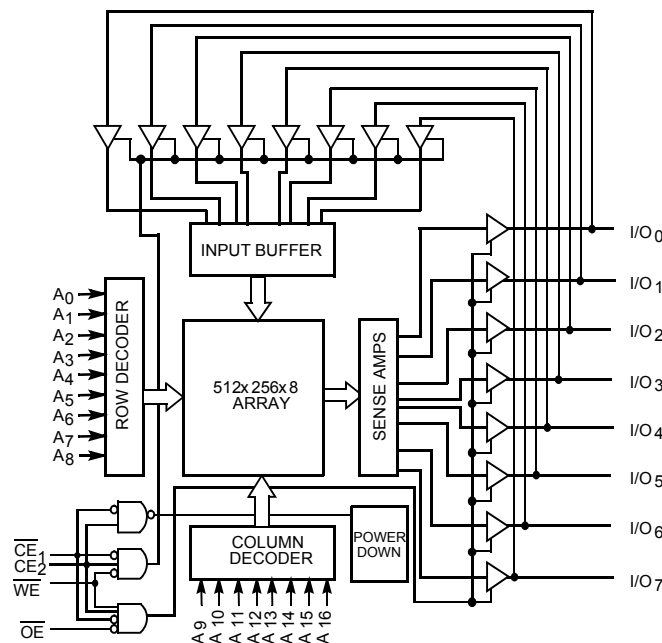

Note:

1. For best practice recommendations, please refer to the Cypress application note "System Design Guidelines" on <http://www.cypress.com>.



Maximum Ratings

(Above which the useful life may be impaired. For user guidelines, not tested.)

- Storage Temperature -65°C to +150°C
- Ambient Temperature with Power Applied..... -55°C to +125°C
- Supply Voltage on V_{CC} to Relative GND^[3] -0.5V to +7.0V
- DC Voltage Applied to Outputs in High-Z State^[3] -0.5V to V_{CC} + 0.5V
- DC Input Voltage^[3]..... -0.5V to V_{CC} + 0.5V

- Current into Outputs (LOW)..... 20 mA
- Static Discharge Voltage..... > 2001V (per MIL-STD-883, Method 3015)
- Latch-up Current..... > 200 mA

Operating Range

Range	Ambient Temperature (T _A) ^[4]	V _{CC}
Commercial	0°C to +70°C	5V ± 10%
Industrial	-40°C to +85°C	5V ± 10%
Automotive	-40°C to +125°C	5V ± 10%

Electrical Characteristics Over the Operating Range

Parameter	Description	Test Conditions	CY62128B-55			CY62128B-70			Unit
			Min.	Typ. ^[2]	Max.	Min.	Typ. ^[2]	Max.	
V _{OH}	Output HIGH Voltage	V _{CC} = Min., I _{OH} = -1.0 mA	2.4			2.4			V
V _{OL}	Output LOW Voltage	V _{CC} = Min., I _{OL} = 2.1 mA			0.4			0.4	V
V _{IH}	Input HIGH Voltage		2.2		V _{CC} + 0.3	2.2		V _{CC} + 0.3	V
V _{IL}	Input LOW Voltage ^[3]		-0.3		0.8	-0.3		0.8	V
I _{IX}	Input Load Current	GND ≤ V _I ≤ V _{CC}	-1		+1	-1		+1	μA
		Automotive				-10		+10	μA
I _{OZ}	Output Leakage Current	GND ≤ V _I ≤ V _{CC} , Output Disabled	-1		+1	-1		+1	μA
		Automotive				-10		+10	μA
I _{OS}	Output Short Circuit Current ^[5]	V _{CC} = Max., V _{OUT} = GND			-300			-300	mA
I _{CC}	V _{CC} Operating Supply Current	V _{CC} = Max., I _{OUT} = 0 mA, f = f _{MAX} = 1/t _{RC}		7.5	20		6	15	mA
		Automotive					6	25	mA
I _{SB1}	Automatic CE Power-down Current —TTL Inputs	Max. V _{CC} , CE ₁ ≥ V _{IH} or CE ₂ ≤ V _{IL} , V _{IN} ≥ V _{IH} or V _{IN} ≤ V _{IL} , f = f _{MAX}		0.1	2		0.1	1	mA
		Automotive					0.1	2	mA
I _{SB2}	Automatic CE Power-down Current —CMOS Inputs	Max. V _{CC} , CE ₁ ≥ V _{CC} - 0.3V, or CE ₂ ≤ 0.3V, V _{IN} ≥ V _{CC} - 0.3V, or V _{IN} ≤ 0.3V, f = 0		2.5	15		2.5	15	μA
		Automotive					2.5	25	μA

Thermal Resistance^[6]

Parameter	Description	Test Conditions	32 SOIC	32 TSOP	32 STSOP	32 RTSOP	Unit
θ _{JA}	Thermal Resistance (Junction to Ambient)	Test conditions follow standard test methods and procedures for measuring thermal impedance, per EIA / JESD51.	66.17	97.44	105.14	97.44	°C/W
θ _{JC}	Thermal Resistance (Junction to Case)		30.87	26.05	14.09	26.05	°C/W

Note:

3. V_{IL} (min.) = -2.0V for pulse durations of less than 20 ns.
4. T_A is the "Instant On" case temperature.
5. Not more than one output should be shorted at one time. Duration of the short circuit should not exceed 30 seconds.
6. Tested initially and after any design or process changes that may affect these parameters.

Capacitance^[6]

Parameter	Description	Test Conditions	Max.	Unit
C_{IN}	Input Capacitance	$T_A = 25^\circ\text{C}, f = 1\text{ MHz},$ $V_{CC} = 5.0\text{V}$	9	pF
C_{OUT}	Output Capacitance		9	pF

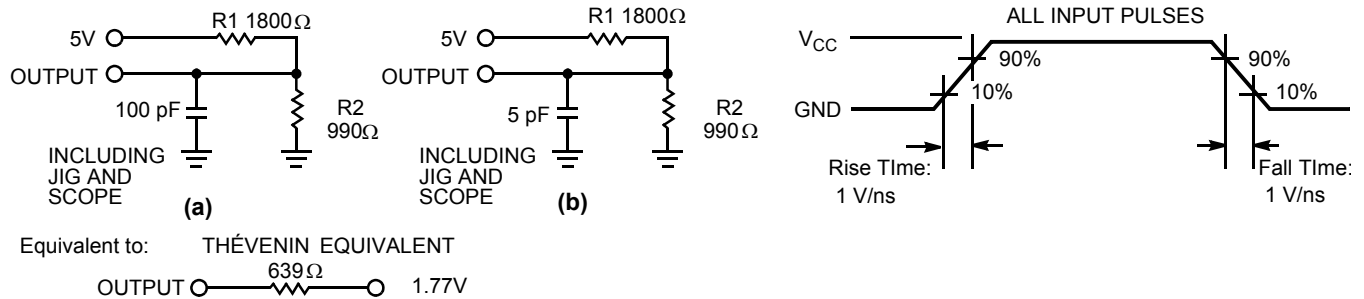
AC Test Loads and Waveforms

Data Retention Characteristics (Over the Operating Range for “LL” version only)

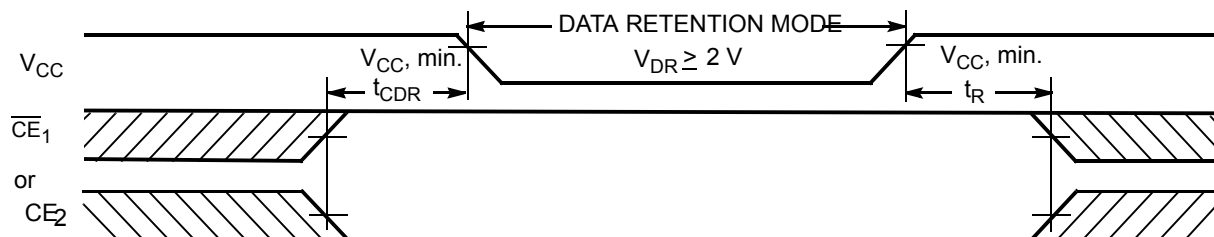
Parameter	Description	Conditions	Min.	Typ.	Max.	Unit
V_{DR}	V_{CC} for Data Retention		2.0			V
I_{CCDR}	Data Retention Current	$V_{CC} = V_{DR} = 2.0\text{V}, CE_1 \geq V_{CC} - 0.3\text{V},$ or $CE_2 \leq 0.3\text{V}, V_{IN} \geq V_{CC} - 0.3\text{V}$ or, $V_{IN} \leq 0.3\text{V}$		1.5	15	μA
t_{CDR}	Chip Deselect to Data Retention Time		0			ns
t_R	Operation Recovery Time		70			ns

Data Retention Waveform

Switching Characteristics^[7] Over the Operating Range

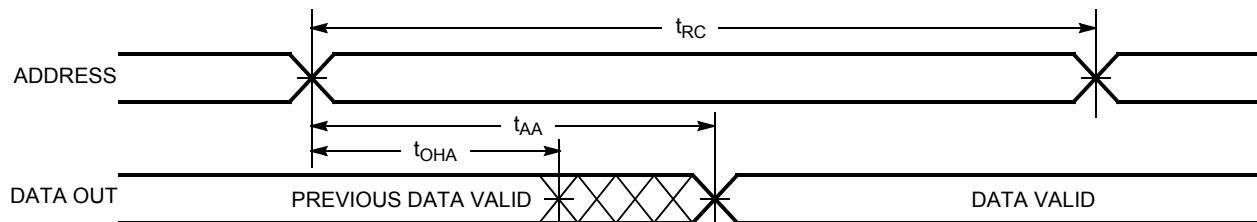
Parameter	Description	62128B-55		62128B-70		Unit
		Min.	Max.	Min.	Max.	
READ CYCLE						
t_{RC}	Read Cycle Time	55		70		ns
t_{AA}	Address to Data Valid		55		70	ns
t_{OHA}	Data Hold from Address Change	5		5		ns
t_{ACE}	\overline{CE}_1 LOW to Data Valid, CE_2 HIGH to Data Valid		55		70	ns
t_{DOE}	\overline{OE} LOW to Data Valid		20		35	ns
t_{LZOE}	\overline{OE} LOW to Low Z	0		0		ns
t_{HZOE}	\overline{OE} HIGH to High Z ^[8, 9]		20		25	ns
t_{LZCE}	\overline{CE}_1 LOW to Low Z, CE_2 HIGH to Low Z ^[9]	5		5		ns
t_{HZCE}	\overline{CE}_1 HIGH to High Z, CE_2 LOW to High Z ^[8, 9]		20		25	ns
t_{PU}	\overline{CE}_1 LOW to Power-up, CE_2 HIGH to Power-up	0		0		ns
t_{PD}	\overline{CE}_1 HIGH to Power-down, CE_2 LOW to Power-down		55		70	ns
WRITE CYCLE^[10]						
t_{WC}	Write Cycle Time	55		70		ns
t_{SCE}	\overline{CE}_1 LOW to Write End, CE_2 HIGH to Write End	45		60		ns
t_{AW}	Address Set-up to Write End	45		60		ns
t_{HA}	Address Hold from Write End	0		0		ns
t_{SA}	Address Set-up to Write Start	0		0		ns
t_{PWE}	\overline{WE} Pulse Width	45		50		ns
t_{SD}	Data Set-up to Write End	25		30		ns
t_{HD}	Data Hold from Write End	0		0		ns
t_{LZWE}	\overline{WE} HIGH to Low Z ^[9]	5		5		ns
t_{HZWE}	\overline{WE} LOW to High Z ^[8, 9]		20		25	ns

Switching Waveforms
Read Cycle No.1^[12, 13]

Notes:

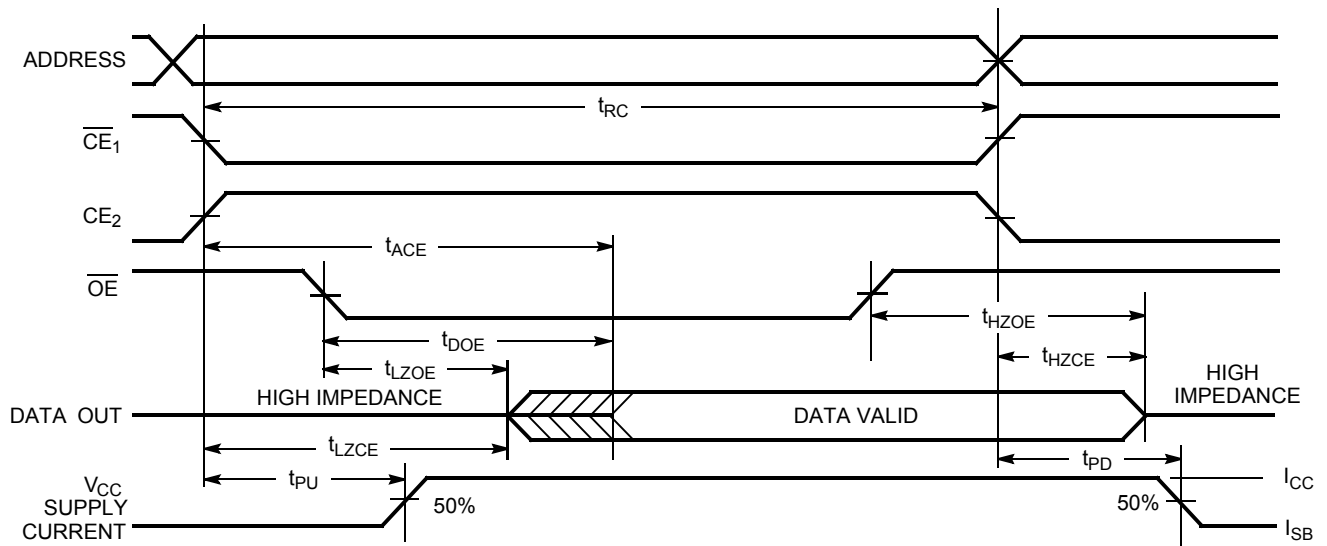
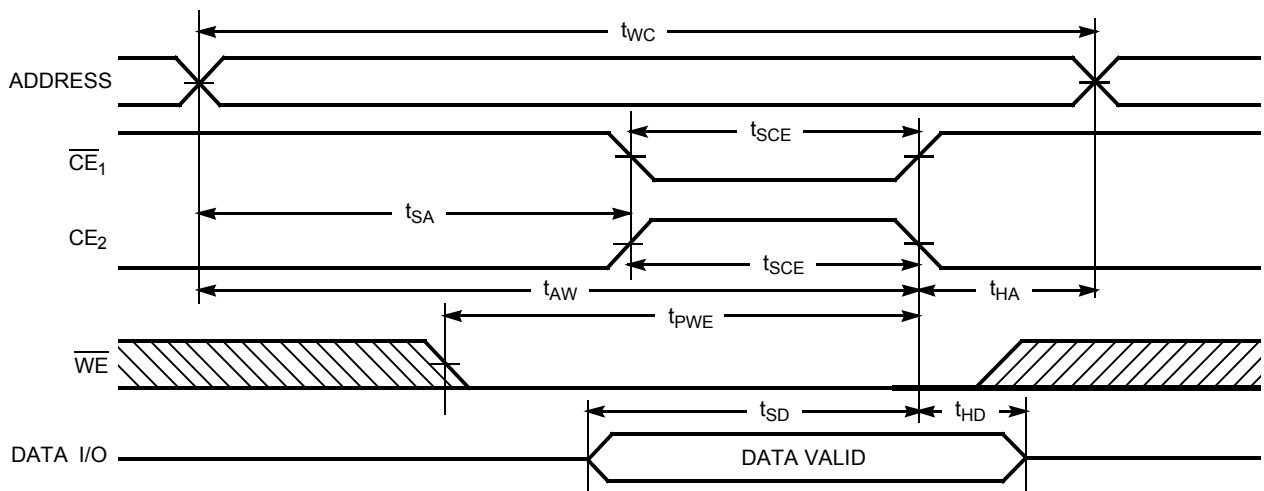
7. Test conditions assume signal transition time of 5 ns or less, timing reference levels of 1.5V, input pulse levels of 0 to 3.0V, and output loading of the specified I_{OL}/I_{OH} and 100-pF load capacitance.
8. t_{HZOE} , t_{HZCE} , and t_{HZWE} are specified with a load capacitance of 5 pF as in (b) of AC Test Loads. Transition is measured ± 500 mV from steady-state voltage.
9. At any given temperature and voltage condition, t_{HZCE} is less than t_{LZCE} , t_{HZOE} is less than t_{LZOE} , and t_{HZWE} is less than t_{LZWE} for any given device.
10. The internal write time of the memory is defined by the overlap of \overline{CE}_1 LOW, CE_2 HIGH, and \overline{WE} LOW. \overline{CE}_1 and \overline{WE} must be LOW and CE_2 HIGH to initiate a write, and the transition of any of these signals can terminate the write. The input data set-up and hold timing should be referenced to the leading edge of the signal that terminates the write.
11. No input may exceed $V_{CC} + 0.5V$.
12. Device is continuously selected. \overline{OE} , $\overline{CE}_1 = V_{IL}$, $CE_2 = V_{IH}$.
13. \overline{WE} is HIGH for read cycle.

Switching Waveforms (continued)
Read Cycle No. 2 (\overline{OE} Controlled)^[13, 14]

Write Cycle No. 1 (\overline{CE}_1 or CE_2 Controlled)^[15, 16]

Notes:

14. Address valid prior to or coincident with \overline{CE}_1 transition LOW and CE_2 transition HIGH.

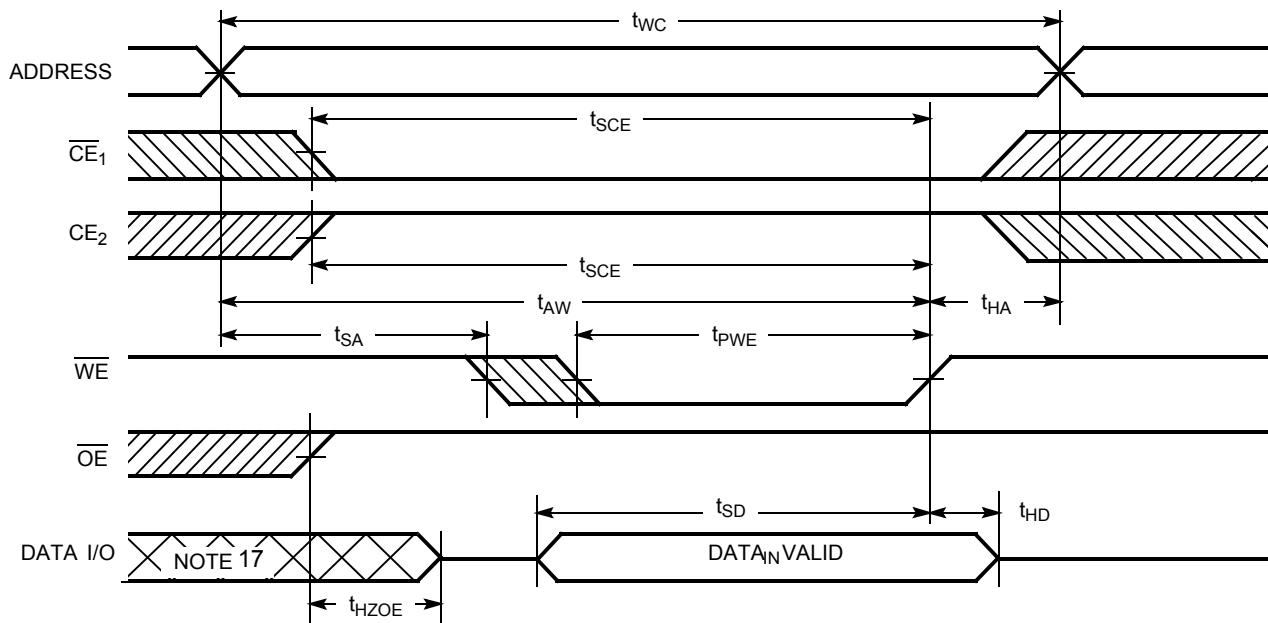
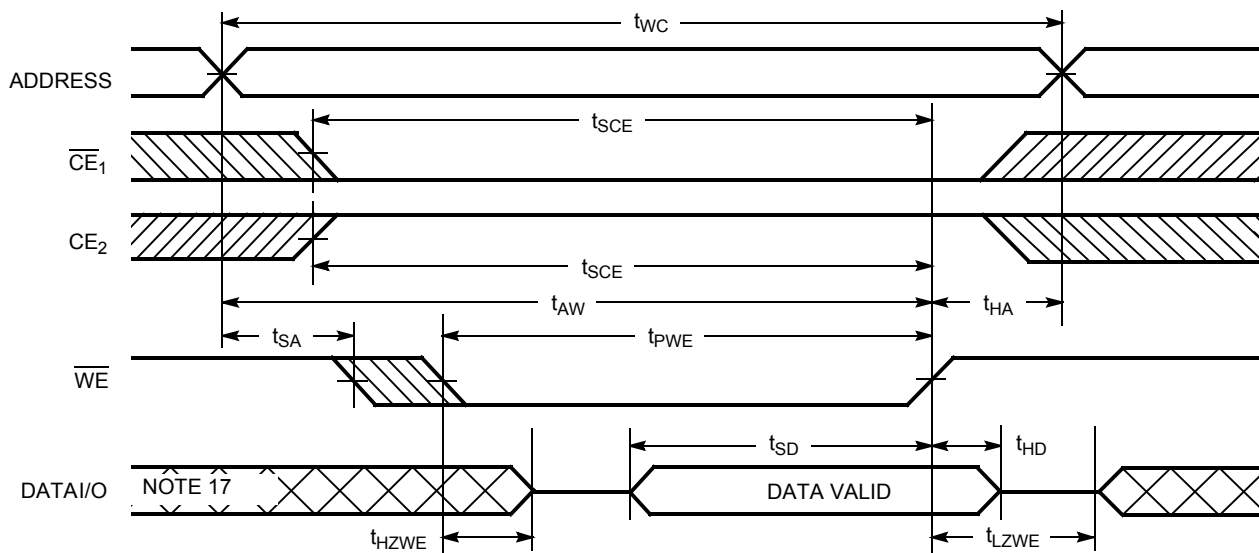
15. Data I/O is high impedance if $\overline{OE} = V_{IH}$.

16. If \overline{CE}_1 goes HIGH or CE_2 goes LOW simultaneously with \overline{WE} going HIGH, the output remains in a high-impedance state.

Switching Waveforms (continued)
Write Cycle No. 2 (\overline{WE} Controlled, \overline{OE} HIGH During Write)^[15, 16]

Write Cycle No.3 (\overline{WE} Controlled, \overline{OE} LOW)^[15, 16]

Note:

17. During this period the I/Os are in the output state and input signals should not be applied.

Truth Table

\overline{CE}_1	\overline{CE}_2	\overline{OE}	\overline{WE}	I/O ₀ -I/O ₇	Mode	Power
H	X	X	X	High Z	Power-down	Standby (I _{SB})
X	L	X	X	High Z	Power-down	Standby (I _{SB})
L	H	L	H	Data Out	Read	Active (I _{CC})
L	H	X	L	Data In	Write	Active (I _{CC})
L	H	H	H	High Z	Selected, Outputs Disabled	Active (I _{CC})

Ordering Information

Speed (ns)	Ordering Code	Package Name	Package Type	Operating Range
55	CY62128BLL-55SI	S34	32-Lead 450-Mil SOIC	Industrial
	CY62128BLL-55SXI	S34	32-Lead 450-Mil SOIC (Pb-free)	Industrial
	CY62128BLL-55SC	S34	32-Lead 450-Mil SOIC	Commercial
	CY62128BLL-55SXC	S34	32-Lead 450-Mil SOIC (Pb-free)	Commercial
	CY62128BLL-55ZI	Z32	32-Lead TSOP Type I	Industrial
	CY62128BLL-55ZXI	Z32	32-Lead TSOP Type I (Pb-free)	Industrial
	CY62128BLL-55ZAI	ZA32	32-Lead STSOP Type I	Industrial
	CY62128BLL-55ZAXI	ZA32	32-Lead STSOP Type I (Pb-free)	Industrial
70	CY62128BLL-70SI	S34	32-Lead 450-Mil SOIC I	Industrial
	CY62128BLL-70SXI	S34	32-Lead 450-Mil SOIC I (Pb-free)	Industrial
	CY62128BLL-70SC	S34	32-Lead 450-Mil SOIC I	Commercial
	CY62128BLL-70SXC	S34	32-Lead 450-Mil SOIC I (Pb-free)	Commercial
	CY62128BLL-70SE	S34	32-Lead 450-Mil SOIC I	Automotive
	CY62128BLL-70SXE	S34	32-Lead 450-Mil SOIC I (Pb-free)	Automotive
	CY62128BLL-70ZI	Z32	32-Lead TSOP Type I	Industrial
	CY62128BLL-70ZXI	Z32	32-Lead TSOP Type I (Pb-free)	Industrial
	CY62128BLL-70ZC	Z32	32-Lead TSOP Type I	Commercial
	CY62128BLL-70ZXC	Z32	32-Lead TSOP Type I (Pb-free)	Commercial
	CY62128BLL-70ZE	Z32	32-Lead TSOP Type I	Automotive
	CY62128BLL-70ZXE	Z32	32-Lead TSOP Type I (Pb-free)	Automotive
	CY62128BLL-70ZAI	ZA32	32-Lead STSOP Type I	Industrial
	CY62128BLL-70ZAXI	ZA32	32-Lead STSOP Type I (Pb-free)	Industrial
	CY62128BLL-70ZAE	ZA32	32-Lead STSOP Type I	Automotive
	CY62128BLL-70ZAXE	ZA32	32-Lead STSOP Type I (Pb-free)	Automotive
CY62128BLL-70ZRXE	ZR32	32-Lead Reverse TSOP Type I (Pb-free)	Automotive	

Package Diagrams

32-Lead (450 MIL) Molded SOIC S34

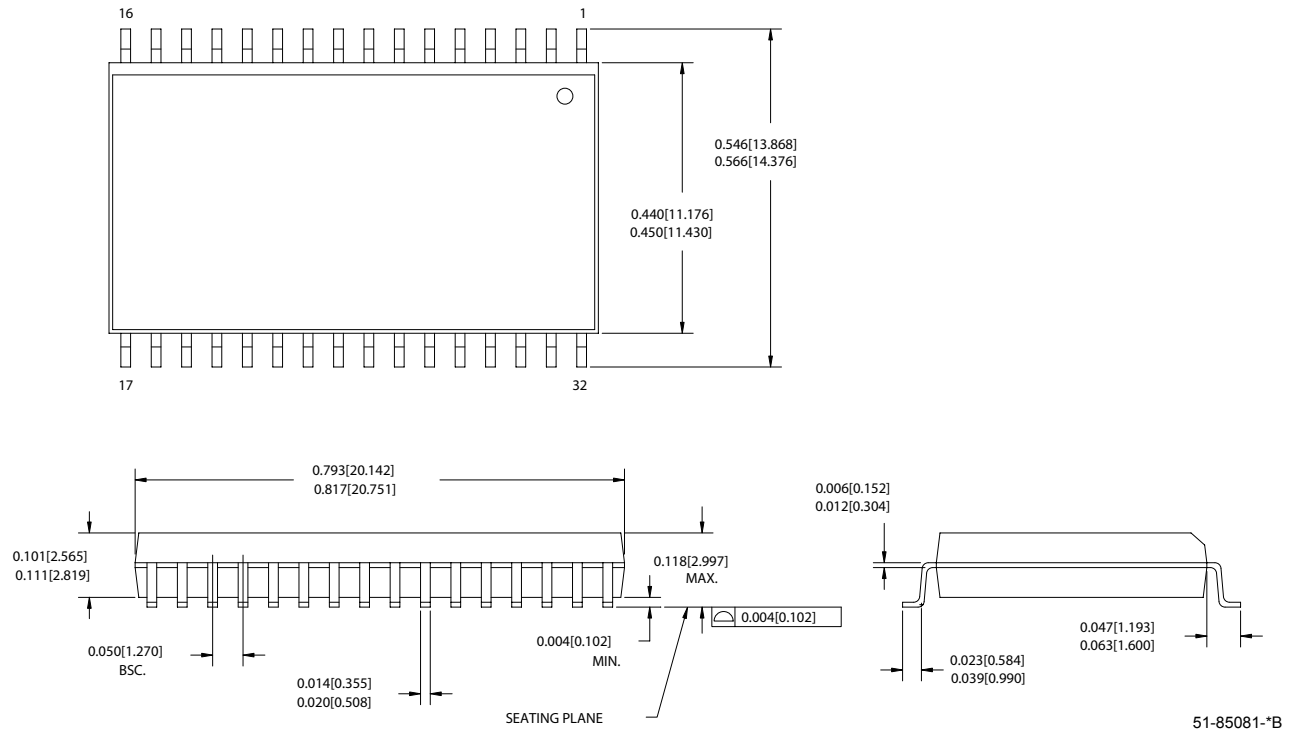

32-Lead Thin Small Outline Package Type I (8x20 mm) Z32

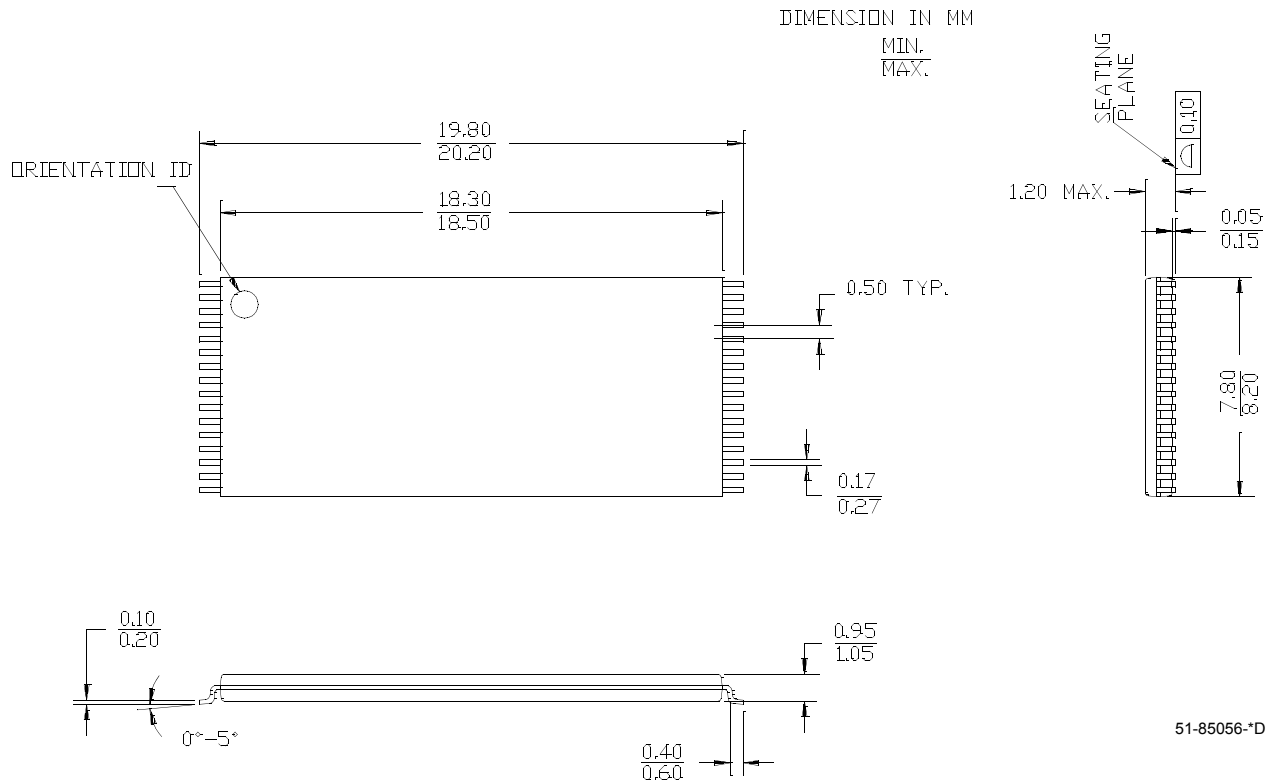

Package Diagrams (continued)

32-Lead Shrunken Thin Small Outline Package (8x13.4 mm) ZA32

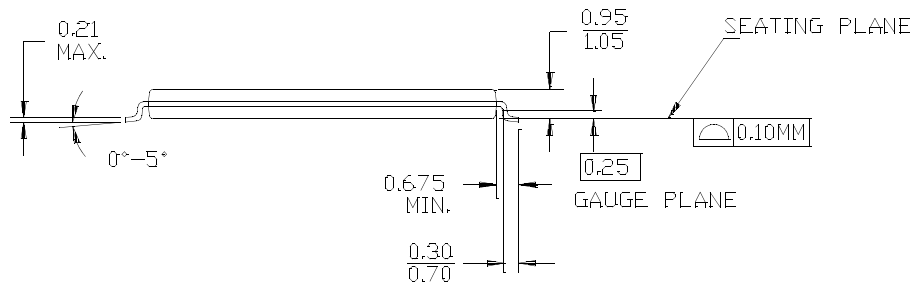
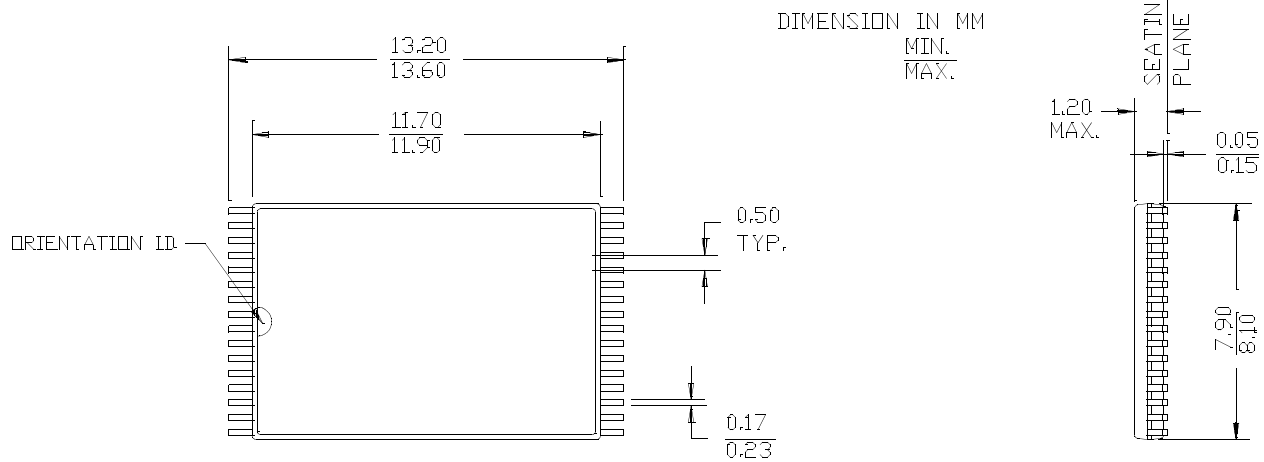

51-85094-*D

32-Lead Reverse Thin Small Outline Package ZR32

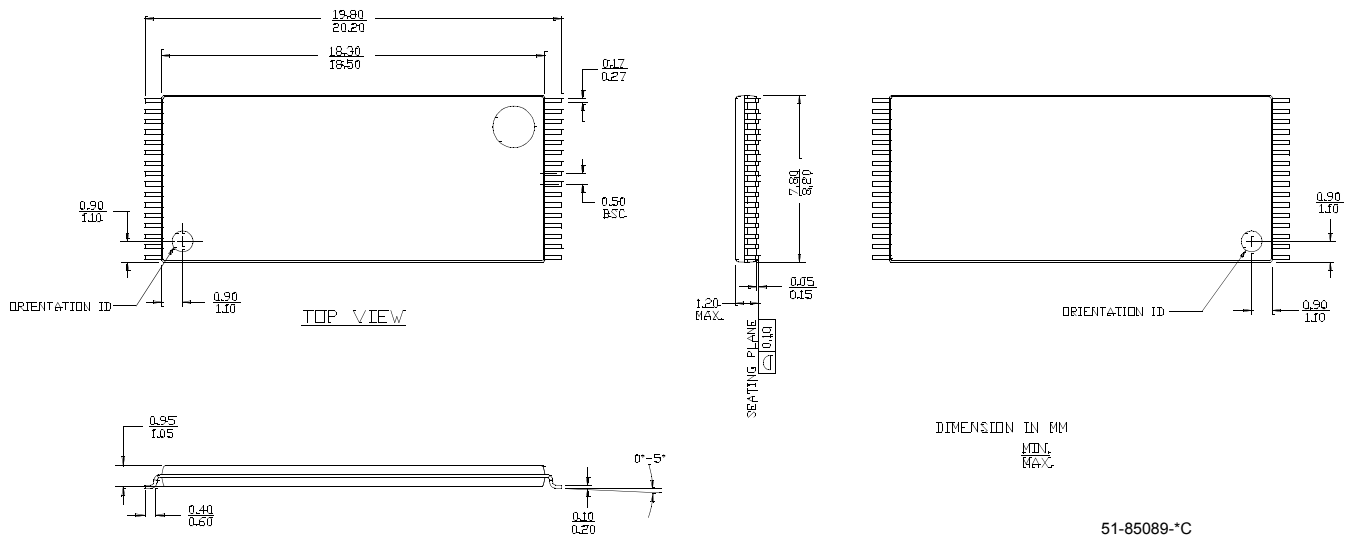

51-85089-*C

MoBL is a registered trademark of Cypress Semiconductor Corporation. All product and company names mentioned in this document are the trademarks of their respective holders.

Document History Page

Document Title: CY62128B MoBL [®] 128K x 8 Static RAM				
Document Number: 38-05300				
REV.	ECN NO.	Issue Date	Orig. of Change	Description of Change
**	116566	06/20/02	DSG	Changed from Spec number: 38-00524 to 38-05300
*A	126601	06/09/03	JUI	Changed CE to CE ₁ and added CE ₂ ≤ 0.3V in Data Retention Characteristics table Removed these part numbers from Ordering Information table: CY62128BLL-55ZC, CY62128BLL-55ZAC, CY62128BLL-55ZRC, CY62128BLL-70ZAC, CY62128BLL-70ZRI, CY62128BLL-70ZRC
*B	239134	See ECN	AJU	Added Thermal Resistance table Added Automotive product information
*C	321335	See ECN	AJU	Added Pb-free package information

Looking for pricing, stock, or lifecycle information?

Click below to explore more details on WIN SOURCE:

- [View CY62128BLL-70ZXI on WIN SOURCE](#)
- [Cypress Semiconductor Corp Information](#)

Optimize Your Supply Chain with WIN SOURCE Solutions

- ✓ Global Sourcing Solution
- ✓ Obsolete Management
- ✓ Cost Control Management
- ✓ Shortage Management
- ✓ Alternative Solution
- ✓ Excess Inventory Management