

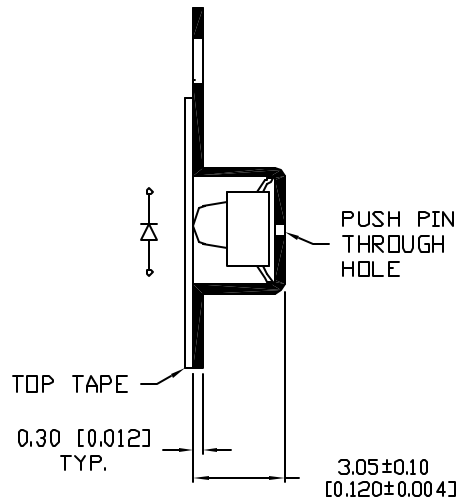

**THE DATASHEET OF
SSL-LXA228YD-TR11**

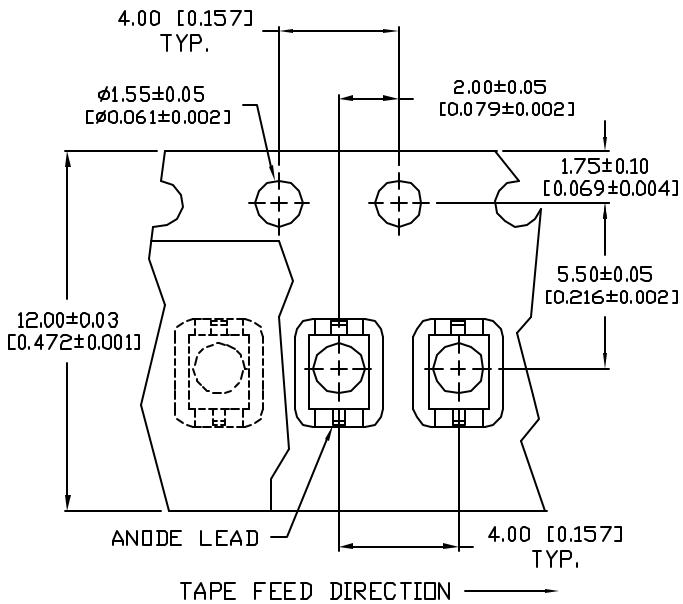

UNCONTROLLED DOCUMENT

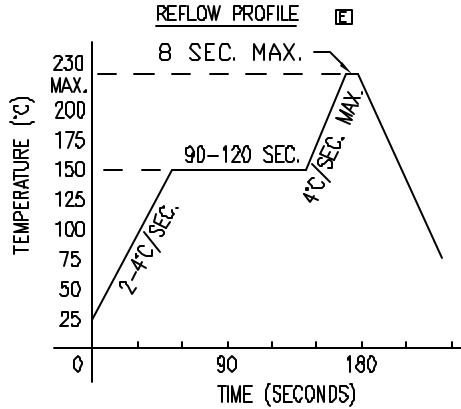
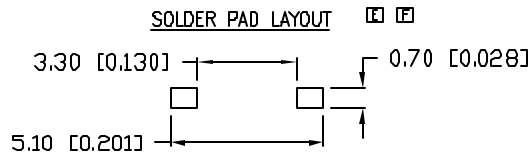
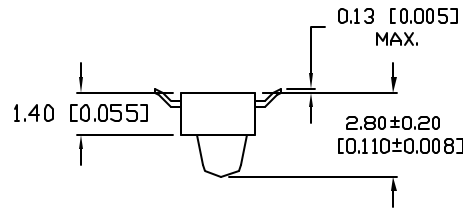
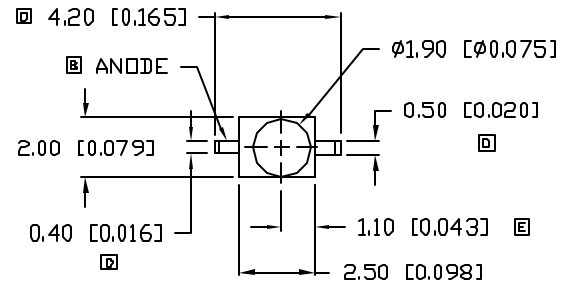

REPLACES PART #: SSL-LX223YD-TR11

PART NUMBER		REV.
SSL-LXA228YD-TR11		G
REV.	E.C.N. NUMBER AND REVISION COMMENTS	DATE
A	CHG'D SOLDERING TEMP.	6-28-94
B	CHG'D SPECS. WHERE NOTED./	8-3-94
C	CHG'D WHERE NOTED./	11-29-94
D	ADDED LEAD WIDTHS, UPDATED LEAD O.A.L./	11-7-95
E	E.C.N. #10550. & #10BRDR.	10-21-99
F	E.C.N. #11146.	7-8-04
G	E.C.N. #11148	11.15.06

ELECTRO-OPTICAL CHARACTERISTICS $T_A=25^\circ\text{C}$ $I_f=20\text{mA}$

PARAMETER	MIN	TYP	MAX	UNITS	TEST COND
PEAK WAVELENGTH		585 (YELLOW)		nm	
FORWARD VOLTAGE		2.1	2.8	V_f	
REVERSE VOLTAGE	5.0			V_r	$I_f=100\mu\text{A}$
AXIAL INTENSITY		15		mcd	$I_f=20\text{mA}$
VIEWING ANGLE		50		2x theta	
EMITTED COLOR: YELLOW					
EPOXY LENS FINISH: YELLOW DIFFUSED					

LIMITS OF SAFE OPERATION AT 25°C

PARAMETER	MAX	UNITS
PEAK FORWARD CURRENT*	150	mA
STEADY CURRENT	30	mA
POWER DISSIPATION	100	mW
DERATE FROM 25°C	-1.2	mW/°C
OPERATING, STORAGE TEMP.	-40 TO +85	°C

* $t < 10\mu\text{s}$

NOTES:

1. 1K PER REEL.



UNCONTROLLED DOCUMENT

*UNLESS OTHERWISE SPECIFIED TOLERANCE IS $\pm 0.25\text{mm}$ ($\pm 0.010"$)

REV.	PART NUMBER
G	SSL-LXA228YD-TR11

CONFIDENTIAL INFORMATION
 THE INFORMATION CONTAINED IN THIS DOCUMENT IS THE PROPERTY OF LUMEX INC. EXCEPT AS SPECIFICALLY AUTHORIZED IN WRITING BY LUMEX INC, THE HOLDER OF THIS DOCUMENT SHALL KEEP ALL INFORMATION CONTAINED HEREIN CONFIDENTIAL AND SHALL PROTECT SAME IN WHOLE OR IN PART FROM DISCLOSURE AND DISSEMINATION TO ALL THIRD PARTIES.

RELIABILITY NOTE
 OUR MANY YEARS OF EXPERIENCE DATA ACCUMULATION INDICATE THAT SOLDER HEAT IS A MAJOR CAUSE OF EARLY AND FUTURE FAILURE. PLEASE PAY ATTENTION TO YOUR SOLDERING PROCESS.

LUMEX INCORPORATED		290 E. HELLEN ROAD PALATINE, ILLINOIS 60067 PHONE: 1-847-359-2790 WEB: HTTP://WWW.LUMEX.COM	
DRAWN BY:	CHECKED BY:	APPROVED BY:	DATE: 11.15.08
J.C.			PAGE: 1 OF 1
			SCALE: N/A

AXIAL LED, 585nm YELLOW LED, YELLOW DIFFUSED LENS,
 GULL WING LEADS, TAPE AND REEL.

Looking for pricing, stock, or lifecycle information?

Click below to explore more details on WIN SOURCE:

- ⊖ [View SSL-LXA228YD-TR11 on WIN SOURCE](#)
- ⊖ [Lumex Opto/Components Inc. Information](#)

Optimize Your Supply Chain with WIN SOURCE Solutions

- ✓ Global Sourcing Solution
- ✓ Obsolete Management
- ✓ Cost Control Management
- ✓ Shortage Management
- ✓ Alternative Solution
- ✓ Excess Inventory Management