

CAUTION: STATIC SENSITIVE DEVICE
FOLLOW PROPER E.S.D. HANDLING PROCEDURES
WHEN WORKING WITH THIS PART.
ESD CLASSIFICATION: CLASS II BASED ON MIL-STD 883E

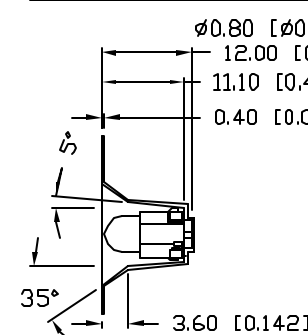

ELECTRO-OPTICAL CHARACTERISTICS $T_A=25^\circ\text{C}$ $I_f=20\text{mA}$

PARAMETER	MIN	TYP	MAX	UNITS	TEST COND
PEAK WAVELENGTH		635 (RED)		nm	
		465 (BLUE)		nm	
		520 (GREEN)		nm	
FORWARD VOLTAGE	(R)	2.2	2.7	V_f	
	(B)	3.4	4.0	V_f	
	(G)	3.4	4.0	V_f	
REVERSE VOLTAGE	5.0			V_r	$I_r=100\mu\text{A}$
AXIAL INTENSITY (R/B/G)	1100/800/2200			mcd	$I_f=20\text{mA}$
VIEWING ANGLE		70		2x theta	
EMITTED COLOR	RED/BLUE/GREEN				
EPOXY LENS FINISH	WATER CLEAR				

LIMITS OF SAFE OPERATION AT 25°C PER DIE.

PARAMETER	COLORS	MAX	UNITS
PEAK FORWARD CURRENT*	R/B/G	100	mA
STEADY CURRENT	R/B/G	30/20/20	mA
POWER DISSIPATION	R/B/G	95/80/80	mW
DERATE FROM 25°C		-1.2	mW/°C
OPERATING TEMP.		-30 TO +80	°C
STORAGE TEMP.		-40 TO +100	°C

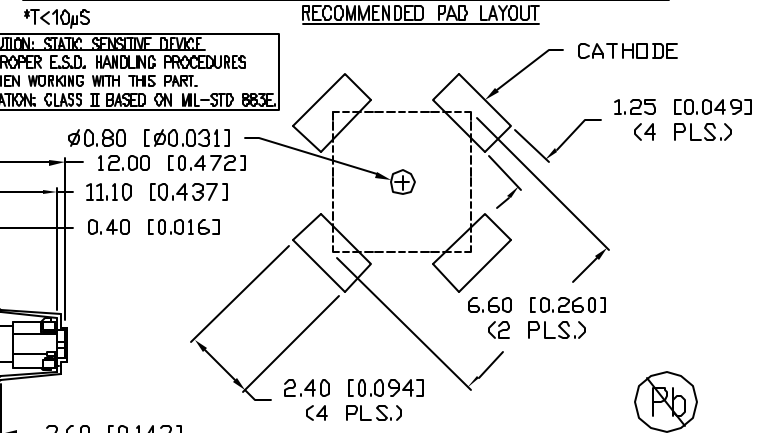

*UNLESS OTHERWISE SPECIFIED TOLERANCES PER DECIMAL PRECISION ARE: X=±1 (±0.039), XX=±0.5 (±0.020), XXX=±0.25 (±0.010), XXXX=±0.127 (±0.005), LEAD SIZE=±0.05 (±0.002), LEAD LENGTH=±0.75 (±0.030), MIN.=+DECIMAL PRECISION -0.00, MAX.=+0.00 -DECIMAL PRECISION

REV.	PART NUMBER
	SML-H1505SIUGUBCTR

5mm SURFACE MOUNT DOMED LED,
RED/BLUE/GREEN, WATER CLEAR LENS.

CONFIDENTIAL INFORMATION
THE INFORMATION CONTAINED IN THIS DOCUMENT IS THE PROPERTY OF LUMEX INC. EXCEPT AS SPECIFICALLY AUTHORIZED IN WRITING BY LUMEX INC., THE HOLDER OF THIS DOCUMENT SHALL KEEP ALL INFORMATION CONTAINED HEREIN CONFIDENTIAL AND SHALL PROTECT SAME IN WHOLE OR IN PART FROM DISCLOSURE AND DISSEMINATION TO ALL THIRD PARTIES.

RELIABILITY NOTE
OUR MANY YEARS OF EXPERIENCE DATA ACCUMULATION INDICATE THAT SOLDER HEAT IS A MAJOR CAUSE OF EARLY AND FUTURE FAILURE. PLEASE PAY ATTENTION TO YOUR SOLDERING PROCESS.

		290 E. HELEN ROAD PALATINE, IL 60067-6976 PHONE: +1.847.359.2790 US WEB: www.lumex.com TW WEB: www.lumex.com.tw
DRAWN BY:	CHECKED BY:	APPROVED BY:
JN		
DATE: 03.31.08		PAGE: 1 OF 1
SCALE: N/A		

Looking for pricing, stock, or lifecycle information?

Click below to explore more details on WIN SOURCE:

- ⊖ [View SML-H1505SIUGUBCTR on WIN SOURCE](#)
- ⊖ [Lumex Opto/Components Inc. Information](#)

Optimize Your Supply Chain with WIN SOURCE Solutions

- ✓ Global Sourcing Solution
- ✓ Obsolete Management
- ✓ Cost Control Management
- ✓ Shortage Management
- ✓ Alternative Solution
- ✓ Excess Inventory Management