



**THE DATASHEET OF  
CY2CP1504ZXC**



# 1:4 LVCMOS to LVPECL Fanout Buffer with Selectable Clock Input

## Features

- Select one of two low-voltage complementary metal oxide semiconductor (LVCMOS) inputs to distribute to four low-voltage positive emitter-coupled logic (LVPECL) output pairs
- 30-ps maximum output-to-output skew
- 480-ps maximum propagation delay
- 0.15-ps maximum additive RMS phase jitter at 156.25 MHz (12-kHz to 20-MHz offset)
- Up to 250 MHz operation
- Synchronous clock enable function
- 20-Pin thin shrunk small outline package (TSSOP) package
- 2.5-V or 3.3-V operating voltage <sup>[1]</sup>
- Commercial and industrial operating temperature range

## Functional Description

The CY2CP1504 is an ultra-low noise, low-skew, low-propagation delay 1:4 LVCMOS to LVPECL fanout buffer targeted to meet the requirements of high-speed clock distribution applications. The CY2CP1504 can select between two separate LVCMOS input clocks using the IN\_SEL pin. The synchronous clock enable function ensures glitch-free output transitions during enable and disable periods. The device has a fully differential internal architecture that is optimized to achieve low additive jitter and low skew at operating frequencies of up to 250 MHz.

For a complete list of related documentation, [click here](#).

## Logic Block Diagram

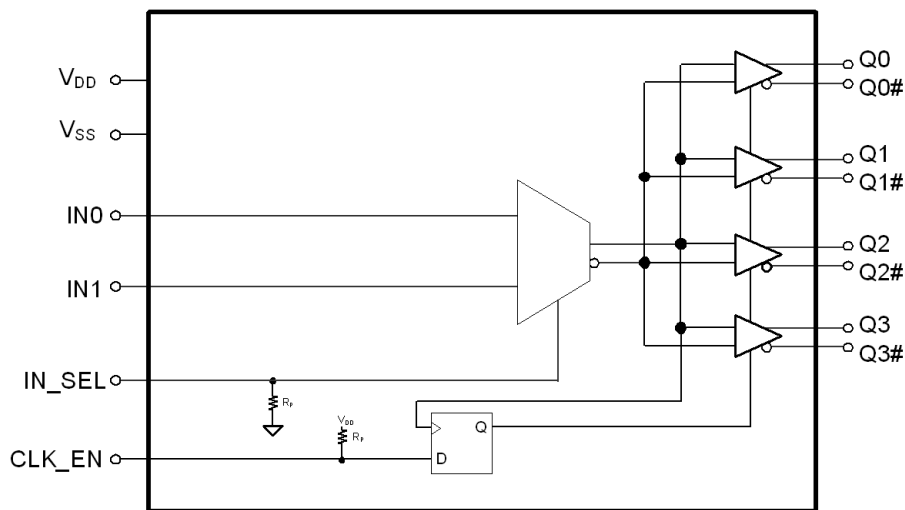

### Note

1. Input AC-coupling capacitors are required for voltage-translation applications.

## Contents

<b>Pin Configurations</b> .....	<b>3</b>	<b>Acronyms</b> .....	<b>11</b>
<b>Pin Definitions</b> .....	<b>3</b>	<b>Document Conventions</b> .....	<b>11</b>
<b>Absolute Maximum Ratings</b> .....	<b>4</b>	Units of Measure .....	11
<b>Operating Conditions</b> .....	<b>4</b>	<b>Document History Page</b> .....	<b>12</b>
<b>DC Electrical Specifications</b> .....	<b>5</b>	<b>Sales, Solutions, and Legal Information</b> .....	<b>14</b>
<b>Thermal Resistance</b> .....	<b>5</b>	Worldwide Sales and Design Support .....	14
<b>AC Electrical Specifications</b> .....	<b>6</b>	Products .....	14
<b>Ordering Information</b> .....	<b>9</b>	PSoC@Solutions .....	14
Ordering Code Definitions .....	9	Cypress Developer Community .....	14
<b>Package Diagram</b> .....	<b>10</b>	Technical Support .....	14

## Pin Configurations

**Figure 1. 20-pin TSSOP Package pinout**

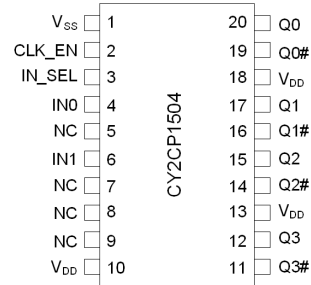

## Pin Definitions

Pin No.	Pin Name	Pin Type	Description
1	V <sub>SS</sub>	Power	Ground
2	CLK_EN	Input	Synchronous clock enable. LVCMOS/low-voltage transistor-transistor logic (LVTTL). When CLK_EN = Low, Q(0:3) outputs are held low and Q(0:3)# outputs are held high
3	IN_SEL	Input	Input clock select pin. LVCMOS/LVTTL; When IN_SEL = Low, input IN0 is active When IN_SEL = High, input IN1 is active
4	IN0	Input	LVCMOS input clock. Active when IN_SEL = Low
5, 7, 8, 9	NC		No connection
6	IN1	Input	LVCMOS input clock. Active when IN_SEL = High
10, 13, 18	V <sub>DD</sub>	Power	Power supply
11, 14, 16, 19	Q(0:3)#	Output	LVPECL complementary output clocks
12, 15, 17, 20	Q(0:3)	Output	LVPECL output clocks

## Absolute Maximum Ratings

Parameter	Description	Condition	Min	Max	Unit
$V_{DD}$	Supply voltage	Nonfunctional	-0.5	4.6	V
$V_{IN}^{[2]}$	Input voltage, relative to $V_{SS}$	Nonfunctional	-0.5	lesser of 4.0 or $V_{DD} + 0.4$	V
$V_{OUT}^{[2]}$	DC output or I/O voltage, relative to $V_{SS}$	Nonfunctional	-0.5	lesser of 4.0 or $V_{DD} + 0.4$	V
$T_S$	Storage temperature	Nonfunctional	-55	150	°C
$ESD_{HBM}$	Electrostatic discharge (ESD) protection (Human body model)	JEDEC STD 22-A114-B	2000	-	V
$L_U$	Latch up		Meets or exceeds JEDEC Spec JESD78B IC latch up test		
UL-94	Flammability rating	At 1/8 in	V-0		
MSL	Moisture sensitivity level		3		

## Operating Conditions

Parameter	Description	Condition	Min	Max	Unit
$V_{DD}$	Supply voltage	2.5 V supply	2.375	2.625	V
		3.3 V supply	3.135	3.465	V
$T_A$	Ambient operating temperature	Commercial	0	70	°C
		Industrial	-40	85	°C
$t_{PU}$	Power ramp time	Power-up time for $V_{DD}$ to reach minimum specified voltage (power ramp must be monotonic)	0.05	500	ms

**Note**

2. The voltage on any I/O pin cannot exceed the power pin during power up. Power supply sequencing is not required.

## DC Electrical Specifications

( $V_{DD} = 3.3\text{ V} \pm 5\%$  or  $2.5\text{ V} \pm 5\%$ ;  $T_A = 0\text{ }^\circ\text{C}$  to  $70\text{ }^\circ\text{C}$  (Commercial) or  $-40\text{ }^\circ\text{C}$  to  $85\text{ }^\circ\text{C}$  (Industrial))

Parameter	Description	Condition	Min	Max	Unit
$I_{DD}$	Operating supply current	All LVPECL outputs floating (internal $I_{DD}$ )	–	61	mA
$V_{IH1}$	Input high voltage, All inputs	$V_{DD} = 3.3\text{ V}$	2.0	$V_{DD} + 0.3$	V
$V_{IL1}$	Input low voltage, All inputs	$V_{DD} = 3.3\text{ V}$	–0.3	0.8	V
$V_{IH2}$	Input high voltage, All inputs	$V_{DD} = 2.5\text{ V}$	1.7	$V_{DD} + 0.3$	V
$V_{IL2}$	Input low voltage, All inputs	$V_{DD} = 2.5\text{ V}$	–0.3	0.7	V
$I_{IH}$	Input high current, All inputs	Input = $V_{DD}$ <sup>[3]</sup>	–	150	$\mu\text{A}$
$I_{IL}$	Input low current, All inputs	Input = $V_{SS}$ <sup>[3]</sup>	–150	–	$\mu\text{A}$
$V_{OH}$	LVPECL output high voltage	Terminated with $50\ \Omega$ to $V_{DD} - 2.0$ <sup>[4]</sup>	$V_{DD} - 1.20$	$V_{DD} - 0.70$	V
$V_{OL}$	LVPECL output low voltage	Terminated with $50\ \Omega$ to $V_{DD} - 2.0$ <sup>[4]</sup>	$V_{DD} - 2.0$	$V_{DD} - 1.63$	V
$R_P$	Internal pull-up/pull-down resistance	CLK_EN has pull-up only IN_SEL has pull-down only	60	165	$\text{k}\Omega$
$C_{IN}$	Input capacitance	Measured at 10 MHz; per pin	–	3	pF

## Thermal Resistance

Parameter <sup>[5]</sup>	Description	Test Conditions	20-pin TSSOP	Unit
$\theta_{JA}$	Thermal resistance (junction to ambient)	Test conditions follow standard test methods and procedures for measuring thermal impedance, in accordance with EIA/JESD51.	80	$^\circ\text{C}/\text{W}$
$\theta_{JC}$	Thermal resistance (junction to case)		16	$^\circ\text{C}/\text{W}$

### Notes

3. Positive current flows into the input pin, negative current flows out of the input pin.
4. Refer to Figure 2 on page 7.
5. These parameters are guaranteed by design and are not tested.

## AC Electrical Specifications

( $V_{DD} = 3.3\text{ V} \pm 5\%$  or  $2.5\text{ V} \pm 5\%$ ;  $T_A = 0\text{ }^\circ\text{C}$  to  $70\text{ }^\circ\text{C}$  (Commercial) or  $-40\text{ }^\circ\text{C}$  to  $85\text{ }^\circ\text{C}$  (Industrial))

Parameter	Description	Condition	Min	Typ	Max	Unit
$F_{IN}$	Input frequency		DC	–	250	MHz
$F_{OUT}$	Output frequency	$F_{OUT} = F_{IN}$	DC	–	250	MHz
$V_{PP}$	LVPECL differential output voltage peak- to-peak, single-ended. Terminated with $50\ \Omega$ to $V_{DD} - 2.0$ [4]	$F_{out} = \text{DC to } 150\text{ MHz}$	600	–	–	mV
		$F_{out} = >150\text{ MHz to } 250\text{ MHz}$	400	–	–	mV
$t_{PD}$ [6]	Propagation delay input to output pair	Input rise/fall time $< 1.5\text{ ns}$ (20% to 80%)	–	–	480	ps
$t_{ODC}$ [7]	Output duty cycle	Rail-to-rail input swing, 50% input DTCY measured at $V_{dd}/2$	45	–	55	%
$t_{SK1}$ [8]	Output-to-output skew	Any output to any output, with same load conditions at DUT	–	–	30	ps
$t_{SK1 D}$ [8]	Device-to-device output skew	Any output to any output between two or more devices. Devices must have the same input and have the same output load.	–	–	150	ps
$PN_{ADD}$	Additive RMS phase noise 156.25-MHz Input Rise/fall time $< 150\text{ ps}$ (20% to 80%) $V_{ID} > 400\text{ mV}$	Offset = 1 kHz	–	–	–120	dBc/Hz
		Offset = 10 kHz	–	–	–130	dBc/Hz
		Offset = 100 kHz	–	–	–135	dBc/Hz
		Offset = 1 MHz	–	–	–150	dBc/Hz
		Offset = 10 MHz	–	–	–150	dBc/Hz
		Offset = 20 MHz	–	–	–150	dBc/Hz
$t_{JIT}$ [9]	Additive RMS phase jitter (Random)	156.25 MHz sinewave, 12 kHz to 20 MHz offset; input swing = $2.2\text{V}$ , $V_{bias} = V_{DD}/2$	–	–	0.15	ps
$t_R, t_F$ [10]	Output rise/fall time	50% duty cycle at input, 20% to 80% of full swing ( $V_{OL}$ to $V_{OH}$ ) Input rise/fall time $< 1.5\text{ ns}$ (20% to 80%)	–	–	300	ps
$t_{SOD}$	Time from clock edge to outputs disabled	Synchronous clock enable (CLK_EN) switched Low	–	–	700	ps
$t_{SOE}$	Time from clock edge to outputs enabled	Synchronous clock enable (CLK_EN) switched high	–	–	700	ps

### Notes

6. Refer to Figure 3 on page 7.
7. Refer to Figure 4 on page 7.
8. Refer to Figure 5 on page 7.
9. Refer to Figure 6 on page 8.
10. Refer to Figure 7 on page 8.

**Figure 2. Output Differential Voltage**

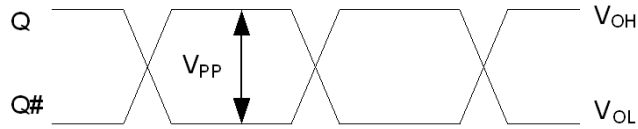

**Figure 3. Input to Any Output Pair Propagation Delay**

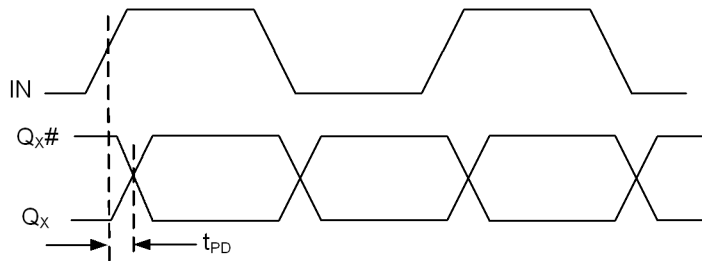

**Figure 4. Output Duty Cycle**

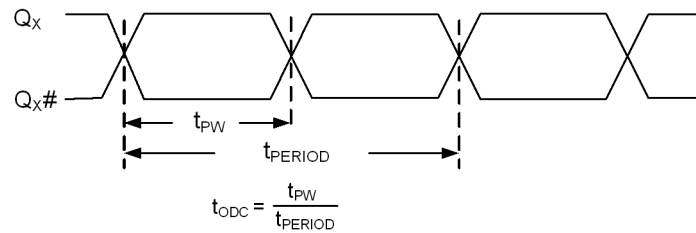

**Figure 5. Output-to-Output and Device-to-Device Skew**

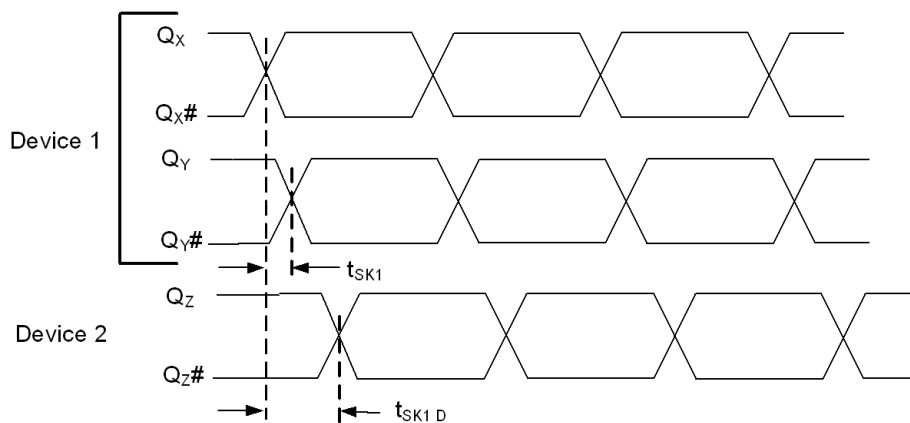

Figure 6. RMS Phase Jitter

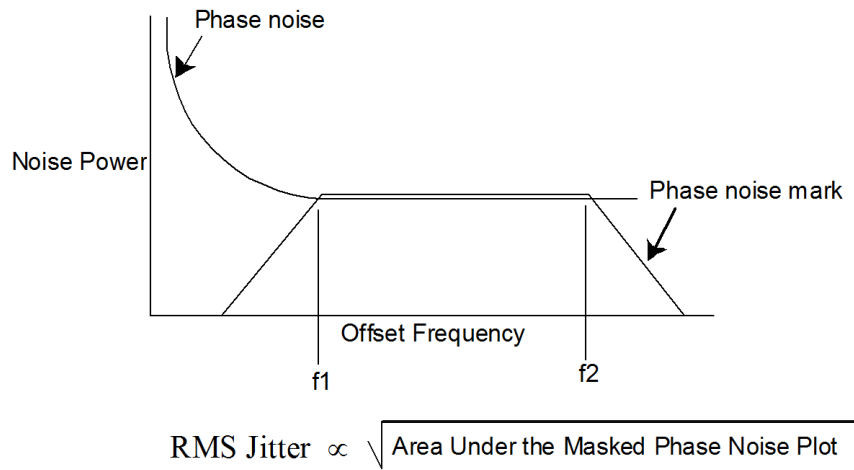

Figure 7. Output Rise/Fall Time

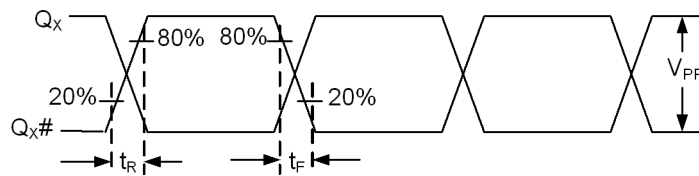
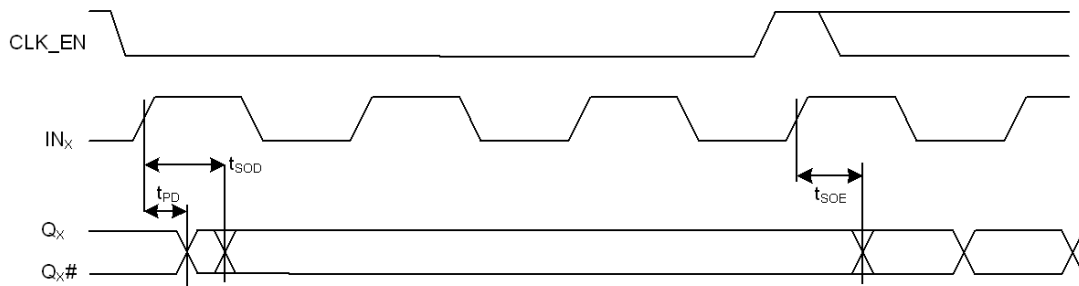

Figure 8. Synchronous Clock Enable Timing



## Ordering Information

Part Number	Type	Production Flow
<b>Pb-free</b>		
CY2CP1504ZXC	20-pin TSSOP	Commercial, 0 °C to 70 °C
CY2CP1504ZXCT	20-pin TSSOP – Tape and Reel	Commercial, 0 °C to 70 °C
CY2CP1504ZXI	20-pin TSSOP	Industrial, –40 °C to 85 °C
CY2CP1504ZXIT	20-pin TSSOP – Tape and Reel	Industrial, –40 °C to 85 °C

## Ordering Code Definitions

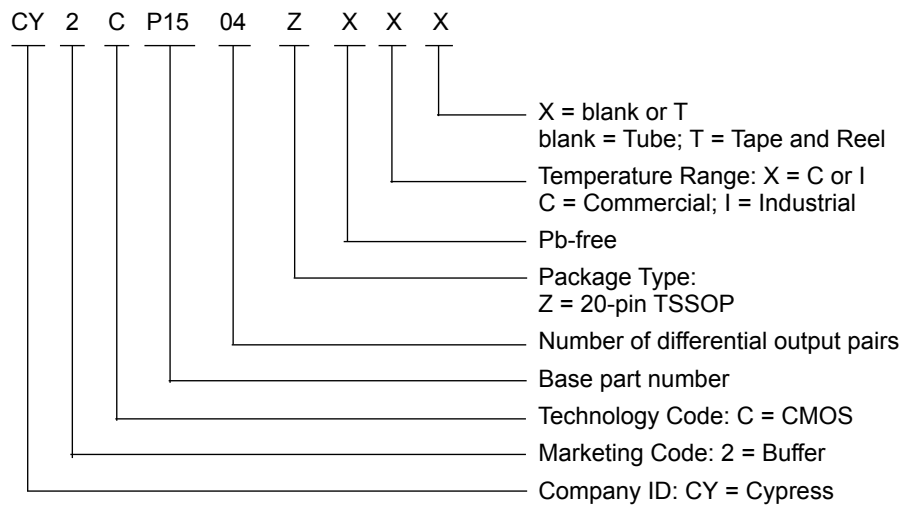

**Package Diagram**

**Figure 9. 20-pin TSSOP (4.40 mm Body) Z20.173/ZZ20.173 Package Outline, 51-85118**

20 Lead TSSOP 4.40 MM BODY

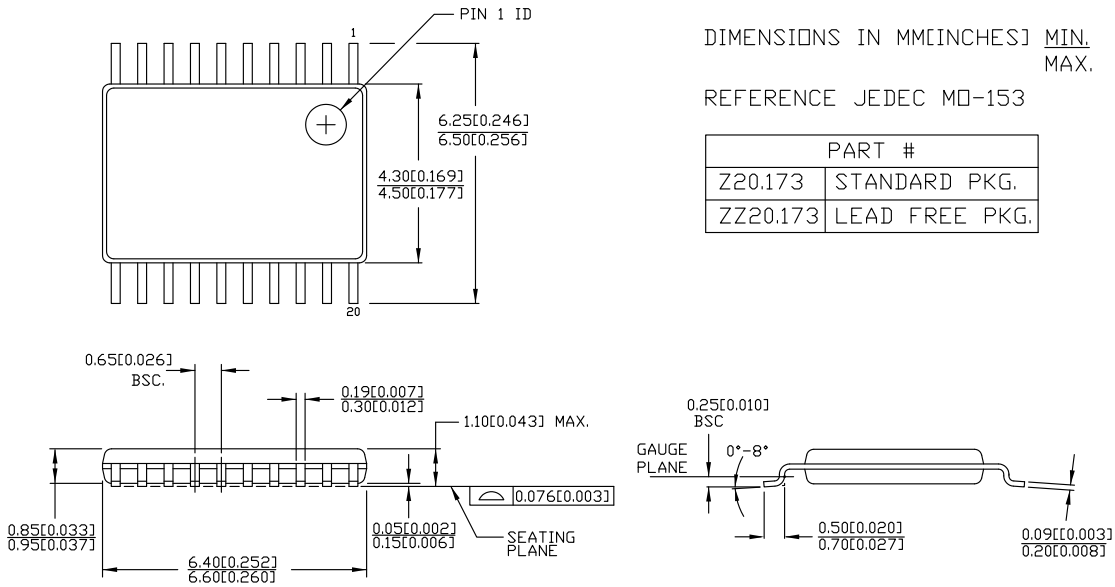

DIMENSIONS IN MM[INCHES] MIN. MAX.

REFERENCE JEDEC MO-153

PART #	
Z20.173	STANDARD PKG.
ZZ20.173	LEAD FREE PKG.

51-85118 \*E

## Acronyms

**Table 1. Acronyms Used in this Document**

Acronym	Description
ESD	electrostatic discharge
HBM	human body model
JEDEC	joint electron devices engineering council
LVDS	low-voltage differential signal
LVC MOS	low-voltage complementary metal oxide semiconductor
LVPECL	low-voltage positive emitter-coupled logic
LVTTTL	low-voltage transistor-transistor logic
RMS	root mean square
TSSOP	thin shrunk small outline package

## Document Conventions

### Units of Measure

**Table 2. Units of Measure**

Symbol	Unit of Measure
°C	degree Celsius
dBc	decibels relative to the carrier
GHz	gigahertz
Hz	hertz
kΩ	kilohm
μA	microampere
μF	microfarad
μs	microsecond
mA	milliampere
ms	millisecond
mV	millivolt
MHz	megahertz
ns	nanosecond
Ω	ohm
pF	picofarad
ps	picosecond
V	volt
W	watt

**Document History Page**

Document Title: CY2CP1504, 1:4 LVCMOS to LVPECL Fanout Buffer with Selectable Clock Input				
Document Number: 001-56313				
Revision	ECN	Orig. of Change	Submission Date	Description of Change
**	2782891	CXQ	10/09/09	New data sheet
*A	2838916	CXQ	05/01/2010	<p>Changed status from “ADVANCE” to “PRELIMINARY”.</p> <p>Changed from 0.34 ps to 0.25 ps maximum additive jitter in “Features” on page 1 and in <math>t_{JIT}</math> in the AC Electrical Specs table on page 5.</p> <p>Added <math>t_{PU}</math> spec to the Operating Conditions table on page 3.</p> <p>Changed max <math>I_{DD}</math> spec in the DC Electrical Specs table on page 4 from 60 mA to 61 mA.</p> <p>Changed <math>V_{OH}</math> in the DC Electrical Specs table on page 4: minimum from <math>V_{DD} - 1.15V</math> to <math>V_{DD} - 1.20V</math>; maximum from <math>V_{DD} - 0.75V</math> to <math>V_{DD} - 0.70V</math>.</p> <p>Removed <math>V_{OD}</math> spec from the DC Electrical Specs table on page 4.</p> <p>Added <math>R_P</math> spec in the DC Electrical Specs table on page 4. Min = 60 k<math>\Omega</math>, Max = 140 k<math>\Omega</math>.</p> <p>Added a measurement definition for <math>C_{IN}</math> in the DC Electrical Specs table on page 4.</p> <p>Added <math>V_{PP}</math> spec to the AC Electrical Specs table on page 5. <math>V_{PP}</math> min = 600 mV for DC - 150 MHz and min = 400 mV for 150 MHz to 250 MHz.</p> <p>Changed letter case and some names of all the timing parameters in the AC Electrical Specs table on page 5 to be consistent with EROS.</p> <p>Lowered all additive phase noise mask specs by 3 dB in the AC Electrical Specs table on page 5.</p> <p>Added condition to <math>t_R</math> and <math>t_F</math> specs in the AC Electrical specs table on page 5 that input rise/fall time must be less than 1.5 ns (20% to 80%).</p> <p>Changed letter case and some names of all the timing parameters in Figures 2, 3, 4, 5 and 7, to be consistent with EROS.</p>
*B	3011766	CXQ	08/20/2010	<p>Changed from 0.25 ps to 0.15 ps maximum additive jitter in “Features” on page 1 and in <math>t_{JIT}</math> in the AC Electrical Specs table on page 6.</p> <p>Added note 2 to describe <math>I_{IH}</math> and <math>I_{IL}</math> specs.</p> <p>Removed reference to data distribution from “Functional Description”.</p> <p>Updated phase noise specs for 1 k/10 k/100 k/1 M/10 M/20 MHz offset to -120/-130/-135/-150/-150/-150dBc/Hz, respectively, in the AC Electrical Specs table.</p> <p>Updated package diagram.</p> <p>Added Acronyms and Ordering Code Definition.</p>
*C	3017258	CXQ	08/27/2010	Corrected Output Rise/Fall time diagram.
*D	3100234	CXQ	11/18/2010	<p>Changed <math>V_{IN}</math> and <math>V_{OUT}</math> specs from 4.0V to “lesser of 4.0 or <math>V_{DD} + 0.4</math>”</p> <p>Removed 200mA min LU spec, replaced with “Meets or exceeds JEDEC Spec JESD78B IC Latchup Test”</p> <p>Changed <math>C_{IN}</math> condition to “Measured at 10 MHz”.</p> <p>Removed <math>t_R</math> and <math>t_F</math> input specs from AC specs table.</p> <p>Changed <math>t_{ODC}</math> from 48/52% to 45/55%, changed condition to “Rail-to-rail input swing, 50% input duty cycle measured at <math>V_{DD}/2</math>”.</p> <p>Changed phase jitter condition to “156.25 MHz sinewave, 12 kHz to 20 MHz offset; input swing = 2.2V, <math>V_{bias} = V_{DD}/2</math>”</p> <p>Removed <math>t_S</math> and <math>t_H</math> specs from AC specs table.</p>
*E	3137726	CXQ	01/13/2011	<p>Removed “Preliminary” status heading.</p> <p>Removed resistors from IN0/IN1 in <a href="#">Logic Block Diagram</a>.</p> <p>Added <a href="#">Figure 8</a> to describe <math>T_{SOE}</math> and <math>T_{SOD}</math>.</p>
*F	3182321	CXQ	02/25/11	Post to external web.
*G	3208968	CXQ	03/29/2011	Changed $R_P$ max from 140 k $\Omega$ to 165 k $\Omega$ and updated $R_P$ in <a href="#">Logic Block Diagram</a> .

**Document History Page** (continued)

Document Title: CY2CP1504, 1:4 LVCMOS to LVPECL Fanout Buffer with Selectable Clock Input Document Number: 001-56313				
Revision	ECN	Orig. of Change	Submission Date	Description of Change
*H	3878020	PURU	01/21/2013	Updated <a href="#">Package Diagram</a> : spec 51-85118 – Changed revision from *C to *D. Updated to new template.
*I	4587249	PURU	12/03/2014	Updated <a href="#">Functional Description</a> : Added “For a complete list of related documentation, <a href="#">click here.</a> ” at the end. Updated <a href="#">Package Diagram</a> : spec 51-85118 – Changed revision from *D to *E.
*J	5267558	PSR	05/13/2016	Added <a href="#">Thermal Resistance</a> . Updated to new template.

## Sales, Solutions, and Legal Information

### Worldwide Sales and Design Support

Cypress maintains a worldwide network of offices, solution centers, manufacturer's representatives, and distributors. To find the office closest to you, visit us at [Cypress Locations](#).

#### Products

ARM® Cortex® Microcontrollers	<a href="http://cypress.com/arm">cypress.com/arm</a>
Automotive	<a href="http://cypress.com/automotive">cypress.com/automotive</a>
Clocks & Buffers	<a href="http://cypress.com/clocks">cypress.com/clocks</a>
Interface	<a href="http://cypress.com/interface">cypress.com/interface</a>
Lighting & Power Control	<a href="http://cypress.com/powerpsoc">cypress.com/powerpsoc</a>
Memory	<a href="http://cypress.com/memory">cypress.com/memory</a>
PSoC	<a href="http://cypress.com/psoc">cypress.com/psoc</a>
Touch Sensing	<a href="http://cypress.com/touch">cypress.com/touch</a>
USB Controllers	<a href="http://cypress.com/usb">cypress.com/usb</a>
Wireless/RF	<a href="http://cypress.com/wireless">cypress.com/wireless</a>

#### PSoC® Solutions

[PSoC 1](#) | [PSoC 3](#) | [PSoC 4](#) | [PSoC 5LP](#)

#### Cypress Developer Community

[Forums](#) | [Projects](#) | [Video](#) | [Blogs](#) | [Training](#) | [Components](#)

#### Technical Support

[cypress.com/support](http://cypress.com/support)

---

© Cypress Semiconductor Corporation, 2009-2016. This document is the property of Cypress Semiconductor Corporation and its subsidiaries, including Spansion LLC ("Cypress"). This document, including any software or firmware included or referenced in this document ("Software"), is owned by Cypress under the intellectual property laws and treaties of the United States and other countries worldwide. Cypress reserves all rights under such laws and treaties and does not, except as specifically stated in this paragraph, grant any license under its patents, copyrights, trademarks, or other intellectual property rights. If the Software is not accompanied by a license agreement and you do not otherwise have a written agreement with Cypress governing the use of the Software, then Cypress hereby grants you a personal, non-exclusive, nontransferable license (without the right to sublicense) (1) under its copyright rights in the Software (a) for Software provided in source code form, to modify and reproduce the Software solely for use with Cypress hardware products, only internally within your organization, and (b) to distribute the Software in binary code form externally to end users (either directly or indirectly through resellers and distributors), solely for use on Cypress hardware product units, and (2) under those claims of Cypress's patents that are infringed by the Software (as provided by Cypress, unmodified) to make, use, distribute, and import the Software solely for use with Cypress hardware products. Any other use, reproduction, modification, translation, or compilation of the Software is prohibited.

TO THE EXTENT PERMITTED BY APPLICABLE LAW, CYPRESS MAKES NO WARRANTY OF ANY KIND, EXPRESS OR IMPLIED, WITH REGARD TO THIS DOCUMENT OR ANY SOFTWARE OR ACCOMPANYING HARDWARE, INCLUDING, BUT NOT LIMITED TO, THE IMPLIED WARRANTIES OF MERCHANTABILITY AND FITNESS FOR A PARTICULAR PURPOSE. To the extent permitted by applicable law, Cypress reserves the right to make changes to this document without further notice. Cypress does not assume any liability arising out of the application or use of any product or circuit described in this document. Any information provided in this document, including any sample design information or programming code, is provided only for reference purposes. It is the responsibility of the user of this document to properly design, program, and test the functionality and safety of any application made of this information and any resulting product. Cypress products are not designed, intended, or authorized for use as critical components in systems designed or intended for the operation of weapons, weapons systems, nuclear installations, life-support devices or systems, other medical devices or systems (including resuscitation equipment and surgical implants), pollution control or hazardous substances management, or other uses where the failure of the device or system could cause personal injury, death, or property damage ("Unintended Uses"). A critical component is any component of a device or system whose failure to perform can be reasonably expected to cause the failure of the device or system, or to affect its safety or effectiveness. Cypress is not liable, in whole or in part, and you shall and hereby do release Cypress from any claim, damage, or other liability arising from or related to all Unintended Uses of Cypress products. You shall indemnify and hold Cypress harmless from and against all claims, costs, damages, and other liabilities, including claims for personal injury or death, arising from or related to any Unintended Uses of Cypress products.

Cypress, the Cypress logo, Spansion, the Spansion logo, and combinations thereof, PSoC, CapSense, EZ-USB, F-RAM, and Traveo are trademarks or registered trademarks of Cypress in the United States and other countries. For a more complete list of Cypress trademarks, visit [cypress.com](http://cypress.com). Other names and brands may be claimed as property of their respective owners.

## Looking for pricing, stock, or lifecycle information?

Click below to explore more details on WIN SOURCE:

- ⊖ [View CY2CP1504ZXC on WIN SOURCE](#)
- ⊖ [Cypress Semiconductor Corp Information](#)

## Optimize Your Supply Chain with WIN SOURCE Solutions

- ✓ Global Sourcing Solution
- ✓ Obsolete Management
- ✓ Cost Control Management
- ✓ Shortage Management
- ✓ Alternative Solution
- ✓ Excess Inventory Management