



**THE DATASHEET OF
CY2544C012**



Quad-PLL Programmable Clock Generator with Spread Spectrum

Features

- Four fully-integrated phase-locked loops (PLLs)
 - External crystal: 8 to 48 MHz for CY2544 and CY2546
 - External reference: 8 to 166 MHz clock
- Input frequency range
 - 2.5 V, 3.0 V, and 3.3 V for CY2548
 - 1.8 V for CY2544 and CY2546
- Reference clock input voltage range
 - 2.5 V, 3.0 V, and 3.3 V for CY2548
 - 1.8 V for CY2544 and CY2546
- Wide operating output frequency range
 - 3 to 166 MHz
- Programmable spread spectrum with center and down spread option and Lexmark and Linear modulation profiles
- V_{DD} supply voltage options:
 - 2.5 V, 3.0 V, and 3.3 V for CY2544 and CY2548
 - 1.8 V for CY2546
- Selectable output clock voltages:
 - 1.8 V, 2.5 V, 3.0 V, and 3.3 V for CY2544 and CY2548
 - 1.8 V for CY2546
- Frequency select feature with option to select eight different frequencies over nine clock outputs
- Power down, output enable, and SS ON/OFF controls
- Low jitter, high accuracy outputs
- Ability to synthesize nonstandard frequencies with Fractional-N capability
- Up to nine clock outputs with programmable drive strength

- Glitch free outputs while frequency switching
- 24-pin QFN package
- Commercial and Industrial temperature ranges
- One-time programmability
For programming support, contact [Cypress technical support](#) or send an e-mail to clocks@cypress.com

Benefits

- Multiple high-performance PLLs allow synthesis of unrelated frequencies
- Nonvolatile programming for personalization of PLL frequencies, spread spectrum characteristics, drive strength, crystal load capacitance, and output frequencies
- Application specific programmable EMI reduction using spread spectrum for clocks
- Programmable PLLs for system frequency margin tests
- Meets critical timing requirements in complex system designs
- Suitability for PC, consumer, portable, and networking applications
- Capable of Zero PPM frequency synthesis error
- Uninterrupted system operation during clock frequency switch
- Application compatibility in standard and low-power systems

Functional Description

For a complete list of related documentation, click [here](#).

Logic Block Diagram

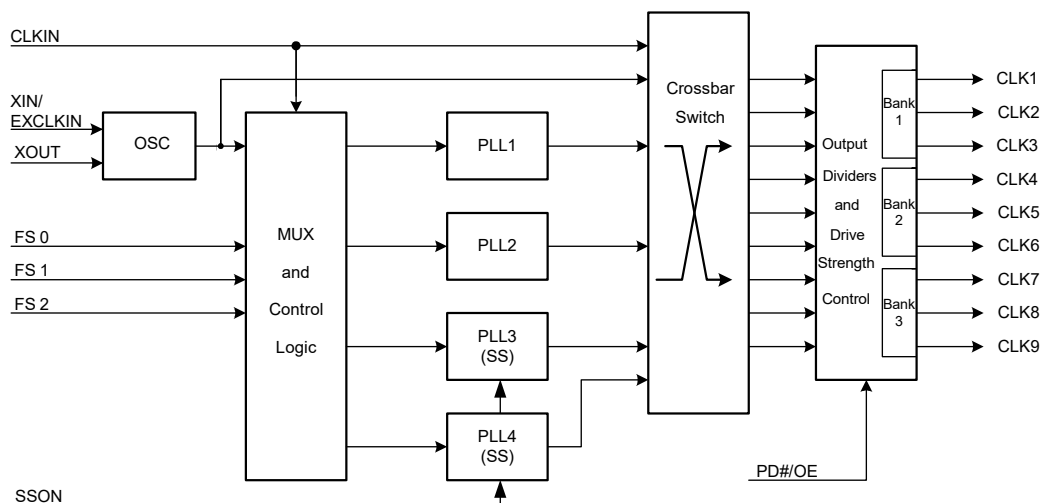

Contents

Device Selection Guide	3	DC Electrical Specifications	7
Pinout	3	AC Electrical Specifications	9
Pin Definitions	3	Configuration Example for C-C Jitter	9
Pinout	4	Recommended Crystal Specification	9
Pin Definitions	5	Recommended Crystal Specification	10
Functional Overview	5	Test and Measurement Setup	10
Four Configurable PLLs	5	Voltage and Timing Definitions	10
Input Reference Clocks	5	Ordering Information	11
Multiple Power Supplies	6	Possible Configurations	11
Output Bank Settings	6	Ordering Code Definitions	12
Output Source Selection	6	Package Drawing and Dimensions	13
Spread Spectrum Control	6	Acronyms	14
Frequency Select	6	Document Conventions	14
Glitch-Free Frequency Switch	6	Units of Measure	14
PD#/OE Mode	6	Document History Page	15
Output Drive Strength	6	Sales, Solutions, and Legal Information	17
Generic Configuration and Custom Frequency	6	Worldwide Sales and Design Support	17
Output Driver Supply	6	Products	17
and Multi-Function Input Restriction	6	PSoC® Solutions	17
Absolute Maximum Conditions	7	Cypress Developer Community	17
Recommended Operating Conditions	7	Technical Support	17

Device Selection Guide

Device	Crystal Input	EXCKLKIN Input	CLKIN Input	V _{DD}	V _{DD_CLK_BX}
CY2544	Yes	1.8 V LVCMOS	2.5 V, 3.0 V, 3.3 V LVCMOS	2.5 V, 3.0 V, 3.3 V	1.8 V, 2.5 V, 3.0 V, 3.3 V
CY2546	Yes	1.8 V LVCMOS	1.8 V LVCMOS	1.8 V	1.8 V
CY2548	No	2.5 V, 3.0 V, 3.3 V LVCMOS	2.5 V, 3.0 V, 3.3 V LVCMOS	2.5 V, 3.0 V, 3.3 V	1.8 V, 2.5 V, 3.0 V, 3.3 V

Pinout

Figure 1. 24-pin QFN pinout
CY2544 / CY2548

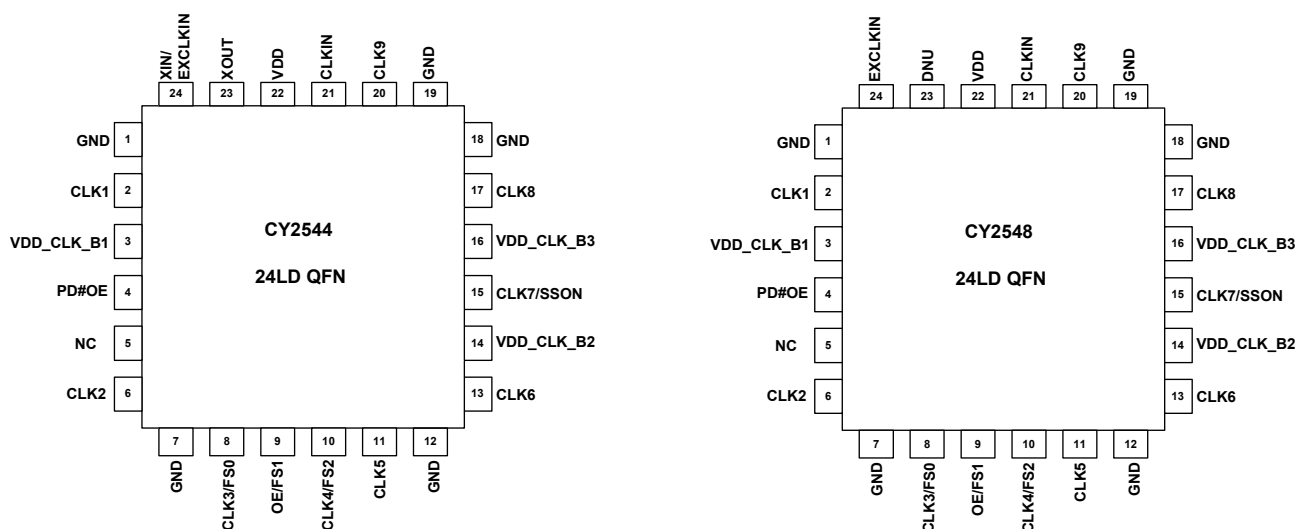

Pin Definitions

CY2544/CY2548 (V_{DD} = 2.5 V, 3.0 V or 3.3 V Supply)

Pin Number	Name	I/O	Description
1	GND	Power	Power supply ground
2	CLK1	Output	Programmable clock output with spread spectrum. Output voltage depends on V _{DD_CLK_B1} voltage
3	V _{DD_CLK_B1}	Power	Power supply for Bank1, (CLK1, CLK2, CLK3) Outputs: 1.8 V/2.5 V/3.0 V/3.3 V
4	PD#/OE	Input	Multifunction programmable pin. Output enable or power-down mode
5	NC	NC	No Connect
6	CLK2	Output	Programmable clock output with spread spectrum. Output voltage depends on V _{DD_CLK_B1} voltage
7	GND	Power	Power supply ground
8	CLK3/FS0	Output/input	Multifunction programmable pin. Programmable clock output with no spread spectrum or frequency select pin. Output voltage of CLK3 depends on V _{DD_CLK_B1} voltage
9	OE/FS1	Input	Multifunction programmable pin. Output enable or frequency select pin
10	CLK4/FS2	Output/input	Multifunction programmable pin. Programmable clock output with no spread spectrum or frequency select input pin. Output voltage of CLK4 depends on V _{DD_CLK_B2} voltage

Pin Definitions (continued)

CY2544/CY2548 ($V_{DD} = 2.5\text{ V}, 3.0\text{ V}$ or 3.3 V Supply)

Pin Number	Name	I/O	Description
11	CLK5	Output	Programmable clock output with no spread spectrum. Output voltage depends on $V_{DD_CLK_B2}$ voltage
12	GND	Power	Power supply ground
13	CLK6	Output	Programmable clock output with spread spectrum. Output voltage depends on $V_{DD_CLK_B2}$ voltage
14	$V_{DD_CLK_B2}$	Power	Power supply for Bank2, (CLK4, CLK5, CLK6) Outputs: 1.8 V/2.5 V/3.0 V/3.3 V
15	CLK7/SSON	Output/input	Multifunction programmable pin. Programmable clock output with spread spectrum or spread spectrum ON/OFF control input pin. Output voltage of CLK7 depends on Bank3 voltage
16	$V_{DD_CLK_B3}$	Power	Power supply for Bank3, (CLK7, CLK8, CLK9) Outputs: 1.8 V/2.5 V/3.0 V/3.3 V
17	CLK8	Output	Programmable output clock with spread spectrum. Output voltage depends on Bank3 voltage
18	GND	Power	Power supply ground
19	GND	Power	Power supply ground
20	CLK9	Output	Programmable clock output with spread spectrum. Output voltage depends on $V_{DD_CLK_B3}$ voltage
21	CLKIN	Input	2.5 V/3.0 V/3.3 V reference clock input. The signal level of CLKIN input must track V_{DD} power supply on pin 22.
22	V_{DD}	Power	Power supply. 2.5 V/3.0 V/3.3 V
23	XOUT	Output	Crystal output for CY2544
	DNU	Output	Do not use this pin for CY2548
24	XIN/EXCLKIN	Input	Crystal input or 1.8 V external clock input for CY2544
	EXCLKIN	Input	2.5 V/3.0 V/3.3 V external clock input for CY2548

Pinout

Figure 2. 24-pin QFN pinout

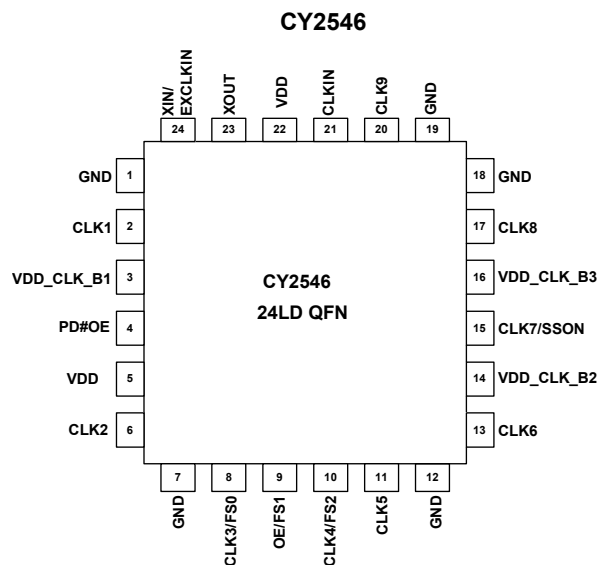

Pin Definitions

CY2546 ($V_{DD} = 1.8\text{ V}$ Supply)

Pin Number	Name	I/O	Description
1	GND	Power	Power supply ground
2	CLK1	Output	Programmable clock output with spread spectrum. Output voltage depends on $V_{DD_CLK_B1}$ voltage
3	$V_{DD_CLK_B1}$	Power	Power supply for Bank1, (CLK1, CLK2, CLK3) Outputs. 1.8 V
4	PD#/OE	Input	Multifunction programmable pin. Output enable or power down mode
5	V_{DD}	Power	Power supply. 1.8 V
6	CLK2	Output	Programmable clock output with spread spectrum. Output voltage depends on $V_{DD_CLK_B1}$ voltage
7	GND	Power	Power supply ground
8	CLK3/FS0	Output/Input	Multifunction programmable pin. Programmable clock output with no spread spectrum or frequency select input pin. Output voltage of CLK3 depends on $V_{DD_CLK_B1}$ voltage
9	OE/FS1	Input	Multifunction programmable pin. Output enable or frequency select pin
10	CLK4/FS2	Output/Input	Multifunction programmable pin. Programmable clock output with no spread spectrum or frequency select input pin. Output voltage of CLK4 depends on $V_{DD_CLK_B2}$ voltage
11	CLK5	Output	Programmable clock output with no spread spectrum. Output voltage depends on $V_{DD_CLK_B2}$ voltage
12	GND	Power	Power supply ground
13	CLK6	Output	Programmable clock output with spread spectrum. Output voltage depends on $V_{DD_CLK_B2}$ voltage
14	$V_{DD_CLK_B2}$	Power	Power supply for Bank2, (CLK4, CLK5, CLK6) Outputs. 1.8 V
15	CLK7/SSON	Output/input	Multifunction programmable pin. Programmable clock output with spread spectrum or spread spectrum ON/OFF control input pin. Output voltage of CLK7 depends on $V_{DD_CLK_B3}$ voltage
16	$V_{DD_CLK_B3}$	Power	Power supply for Bank3, (CLK7, CLK8, CLK9) Outputs. 1.8 V
17	CLK8	Output	Programmable clock output with spread spectrum. Output voltage depends on $V_{DD_CLK_B3}$ voltage
18	GND	Power	Power supply ground
19	GND	Power	Power supply ground
20	CLK9	Output	Programmable clock output with spread spectrum. Output voltage depends on $V_{DD_CLK_B3}$ voltage
21	CLKIN	Input	External 1.8 V low voltage reference clock input
22	V_{DD}	Power	Power supply. 1.8 V
23	XOUT	Output	Crystal output
24	XIN/EXCLKIN	Input	Crystal input or 1.8 V external clock input

Functional Overview

Four Configurable PLLs

The CY2544, CY2548, and CY2546 have four programmable PLLs that can be used to generate output frequencies ranging from 3 to 166 MHz. The advantage of having four PLLs is that a single device generates up to four independent frequencies from a single crystal.

Input Reference Clocks

The input to the CY2544, CY2548 and CY2546 can be either a crystal or a clock signal. The input frequency range for crystal (XIN) is 8 MHz to 48 MHz and that for external reference clock (EXCLKIN) is 8 MHz to 166 MHz. The voltage range for the reference clock input of CY2548 is 2.5 V/3.0 V/3.3 V while that for CY2544 and CY2546 is 1.8 V. This gives user an option for this device to be compatible for different input clock voltage levels in the system.

There is provision for a secondary reference clock input, CLKIN with applied frequency range of 8 MHz to 166 MHz. When CLKIN signal at pin 21 is used as a reference input to the PLL, a valid signal at EXCLKIN (as specified in the AC and DC Electrical Specification table) must be present for the devices to operate properly.

Multiple Power Supplies

These devices are designed to operate at internal supply voltage of 1.8 V. In the case of the high voltage part (CY2544/CY2548), an internal regulator is used to generate 1.8 V from the 2.5 V/3.0 V/3.3 V V_{DD} supply voltage at pin 22. For the low voltage part (CY2546), this internal regulator is bypassed and 1.8 V at V_{DD} pin 22 is directly used.

Output Bank Settings

There are nine clock outputs grouped in three output driver banks. The Bank 1, Bank 2, and Bank 3 correspond to (CLK1, CLK2, CLK3), (CLK4, CLK5, CLK6), and (CLK7, CLK8, CLK9) respectively. Separate power supplies are used for each of these banks and they can be any of 1.8 V, 2.5 V, 3.0 V, or 3.3 V for CY2544/CY2548 and 1.8 V for CY2546 giving user multiple choice of output clock voltage levels.

Output Source Selection

These devices have programmable input sources for each of its nine clock outputs (CLK1–9). There are six available clock sources for these outputs. These clock sources are: XIN/EXCLKIN, CLKIN, PLL1, PLL2, PLL3, or PLL4. Output clock source selection is done using four out of six crossbar switch. Thus, any one of these six available clock sources can be arbitrarily selected for the clock outputs. This gives user a flexibility to have up to four independent clock outputs.

Spread Spectrum Control

Two of the four PLLs (PLL3 and PLL4) have spread spectrum capability for EMI reduction in the system. The device uses a Cypress proprietary PLL and spread spectrum clock (SSC) technology to synthesize and modulate the frequency of the PLL. The spread spectrum feature can be turned on or off using a multifunction control pin (CLK7/SSON). It can be programmed to either center spread range from $\pm 0.125\%$ to $\pm 2.50\%$ or down spread range from -0.25% to -5.0% with Lexmark or Linear profile.

Frequency Select

There are three multifunction frequency select pins (FS0, FS1 and FS2) that provide an option to select eight different sets of frequencies among each of the four PLLs. Each output has programmable output divider options.

Glitch-Free Frequency Switch

When the frequency select pin (FS) is used to switch frequency, the outputs are glitch-free provided frequency is switched using output dividers. This feature enables uninterrupted system operation while clock frequency is being switched.

PD#/OE Mode

PD#/OE (Pin 4) can be programmed to operate as either power down (PD#) or output enable (OE) mode. PD# is a low-true input. If activated it shuts off the entire chip, resulting in minimum power consumption for the device. Setting this signal high brings the device in the operational mode with default register settings.

When this pin is programmed as Output Enable (OE), clock outputs can be enabled or disabled using OE (pin 4). Individual clock outputs can be programmed to be sensitive to this OE pin.

Output Drive Strength

The DC drive strength of the individual clock output can be programmed for different values. Table 1 shows the typical rise and fall times for different drive strength settings.

Table 1. Output Drive Strength

Output Drive Strength	Rise/Fall Time (ns) (Typical Value)
Low	6.8
Mid Low	3.4
Mid High	2.0
High	1.0

Generic Configuration and Custom Frequency

There is a generic set of output frequencies available from the factory that can be used for the device evaluation purposes. The devices, CY2544, CY2548 and CY2546 can be custom programmed to any desired frequencies and listed features. For customer specific programming, contact your local Cypress Field application engineer (FAE) or sales representative.

Output Driver Supply and Multi-Function Input Restriction

There are three programmable Output/Input function pins, for CLK3/FS0, CLK4/FS2, and CLK7/SSON. These are configurable as clock output or select input or spread spectrum ON/OFF control input pin.

- When configured as Output, the driver supply voltage is defined by $V_{DD_CLK_Bx}$ and can be individually used with 1.8 V, 2.5 V, 3.0 V, or 3.3 V power supply apart from the V_{DD} supply.
- When configured as Input, the input threshold level is defined by V_{DD} supply while the protection diode is connected to the respective $V_{DD_CLK_Bx}$ power supply. Therefore, if $V_{DD_CLK_Bx}$ is less than $V_{DD} - 0.5$ V, a large leakage current would flow from the input pin to the $V_{DD_CLK_Bx}$ supply. The device does not permit this condition; it is required that the power supply for the bank ($V_{DD_CLK_Bx}$) is more than $V_{DD} - 0.5$ V.

Example: In CY2544/CY2548, if $V_{DD_CLK_B1} = 1.8$ V, CLK3/FS0 is configured as FS0, and $V_{DD} = 3.3$ V, there will be a leakage current from FS0 high to $V_{DD_CLK_B1}$. The multi-function pin should only be used as clock output if the $V_{DD_CLK_Bx}$ is less than $V_{DD} - 0.5$ V. In other words, when these multi-function programmable pins are configured as input, the power supply for the bank ($V_{DD_CLK_Bx}$) should be more than $V_{DD} - 0.5$ V.

Absolute Maximum Conditions

Parameter	Description	Conditions	Min	Max	Unit
V _{DD}	Supply voltage for CY2544/CY2548		-0.5	4.5	V
V _{DD}	Supply voltage for CY2546		-0.5	2.6	V
V _{DD_CLK_BX}	Output bank supply voltage		-0.5	4.5	V
V _{IN}	Input voltage for CY2544/CY2548	Relative to V _{SS}	-0.5	V _{DD} + 0.5	V
V _{IN}	Input voltage for CY2546	Relative to V _{SS}	-0.5	2.2	V
T _S	Temperature, storage	Non functional	-65	+150	°C
ESD _{HBM}	ESD protection (Human body model)	JEDEC EIA/JESD22-A114-E	2000	-	V
UL-94	Flammability rating	V-0 at 1/8 in.	-	10	ppm
MSL	Moisture sensitivity level		3		

Recommended Operating Conditions

Parameter	Description	Min	Typ	Max	Unit
V _{DD}	V _{DD} operating voltage for CY2544/CY2548	2.25	-	3.60	V
V _{DD}	V _{DD} operating voltage for CY2546	1.65	1.8	1.95	V
V _{DD_CLK_BX}	Output driver voltage for Bank 1, 2 and 3 for CY2544/CY2548	1.43	-	3.60	V
	Output driver voltage for Bank 1, 2 and 3 for CY2546	1.43	-	1.98	V
T _{AC}	Commercial ambient temperature	0	-	+70	°C
T _{AI}	Industrial ambient temperature	-40	--	+85	°C
C _{LOAD}	Maximum load capacitance	-	-	15	pF
t _{PU}	Power up time for all V _{DD} to reach minimum specified voltage (power ramps must be monotonic)	0.05	-	500	ms

DC Electrical Specifications

Parameter	Description	Conditions	Min	Typ	Max	Unit
V _{OL}	Output low voltage	I _{OL} = 2 mA, drive strength = [00]	-	-	0.4	V
		I _{OL} = 3 mA, drive strength = [01]				
		I _{OL} = 7 mA, drive strength = [10]				
		I _{OL} = 12 mA, drive strength = [11]				
V _{OH}	Output high voltage	I _{OH} = -2 mA, drive strength = [00]	V _{DD_CLK_BX} - 0.4	-	-	V
		I _{OH} = -3 mA, drive strength = [01]				
		I _{OH} = -7 mA, drive strength = [10]				
		I _{OH} = -12 mA, drive strength = [11]				
V _{IL1}	Input low voltage of PD#/OE, FS0, FS1, FS2 and SSON	-	-	-	0.2 × V _{DD}	V
V _{IL2}	Input low voltage of CLKIN for CY2544/CY2548	-	-	-	0.2 × V _{DD}	V

DC Electrical Specifications (continued)

Parameter	Description	Conditions	Min	Typ	Max	Unit
V _{IL3}	Input low voltage of EXCLKIN for CY2544	–	–	–	0.3	V
V _{IL4}	Input low voltage of EXCLKIN for CY2548	–	–	–	0.2 × V _{DD}	V
V _{IL5}	Input low voltage of CLKIN, EXCLKIN for CY2546	–	–	–	0.2 × V _{DD}	V
V _{IH1}	Input high voltage of PD#/OE, FS0, FS1, FS2 and SSON	–	0.8 × V _{DD}	–	–	V
V _{IH2}	Input high voltage of CLKIN for CY2544/CY2548	–	0.8 × V _{DD}	–	–	V
V _{IH3}	Input high voltage of EXCLKIN for CY2544	–	1.6	–	2.2	V
V _{IH4}	Input high voltage of EXCLKIN for CY2548	–	0.8 × V _{DD}	–	–	V
V _{IH5}	Input high voltage of CLKIN, EXCLKIN for CY2546	–	0.8 × V _{DD}	–	–	V
I _{IL1}	Input low current of PD#/OE and FS1	V _{IL} = 0 V	–	–	10	μA
I _{IH1}	Input high current of PD#/OE and FS1	V _{IH} = V _{DD}	–	–	10	μA
I _{IL2}	Input low current of SSON, FS0, and FS2	V _{IL} = 0 V (Internal pull dn = 160k typ)	–	–	10	μA
I _{IH2}	Input high current of SSON, FS0, and FS2	V _{IH} = V _{DD} (Internal pull dn = 160k typ)	14	–	36	μA
R _{DN}	Pull down resistor of SSON, FS0, FS2 and clocks (CLK1–CLK9) in off-state	Clock outputs in off-state by setting PD# = Low	100	160	250	kΩ
I _{DD} ^[1, 2]	Supply current for CY2546	PD# = High, No load	–	20	–	mA
	Supply current for CY2544/CY2548	PD# = High, No load	–	22	–	mA
I _{DDS} ^[1]	Standby current	PD# = Low	–	3	–	μA
C _{IN} ^[1]	Input capacitance	SSON, CLKIN, PD#/OE, FS0, FS1, and FS2 pins	–	–	7	pF

Notes

1. Guaranteed by design but not 100% tested.
2. Configuration dependent.

AC Electrical Specifications

Parameter	Description	Conditions	Min	Typ	Max	Unit
F _{IN} (crystal)	Crystal frequency, XIN	–	8	–	48	MHz
F _{IN} (clock)	Input clock frequency (CLKIN or EXCLKIN)	–	8	–	166	MHz
F _{CLK}	Output clock frequency	CY2544/CY2548 (V _{DD_CLK_BX} = 2.5 V, 3.0 V, 3.3 V) and CY2546	3	–	166	MHz
		CY2544/CY2548 (V _{DD_CLK_BX} = 1.8 V)	3	–	50	MHz
DC1	Output duty cycle, All clocks except ref out	Duty cycle is defined in Figure 4 ; t ₁ /t ₂ , measured at 50% of V _{DD_CLK_BX}	45	50	55	%
DC2	Ref Out clock duty cycle	Ref In Min 45%, Max 55%	40	–	60	%
T _{RF1} ^[3]	Output rise/fall Time	Measured from 20% to 80% of V _{DD_CLK_BX} , as shown in Figure 5 , C _{LOAD} = 15 pF, Drive strength [00]	–	6.8	–	ns
T _{RF2} ^[3]	Output rise/fall time	Measured from 20% to 80% of V _{DD_CLK_BX} , as shown in Figure 5 , C _{LOAD} = 15 pF, Drive strength [01]	–	3.4	–	ns
T _{RF3} ^[3]	Output rise/fall time	Measured from 20% to 80% of V _{DD_CLK_BX} , as shown in Figure 5 , C _{LOAD} = 15 pF, Drive strength [10]	–	2.0	–	ns
T _{RF4} ^[3]	Output rise/fall time	Measured from 20% to 80% of V _{DD_CLK_BX} , as shown in Figure 5 , C _{LOAD} = 15 pF, Drive strength [11]	–	1.0	–	ns
T _{CCJ} ^[3,4]	Cycle-to-cycle Jitter (peak)	Configuration dependent. See Configuration Example for C-C Jitter	–	150	–	ps
T _{LOCK} ^[3]	PLL lock time	Measured from 90% of the applied power supply level	–	1	3	ms

Configuration Example for C-C Jitter

Ref. Freq. (MHz)	CLK1 Output		CLK2 Output		CLK3 Output		CLK4 Output		CLK5 Output	
	Freq. (MHz)	C-C Jitter Typ (ps)	Freq. (MHz)	C-C Jitter Typ (ps)	Freq. (MHz)	C-C Jitter Typ (ps)	Freq. (MHz)	C-C Jitter Typ (ps)	Freq. (MHz)	C-C Jitter Typ (ps)
14.3181	8.0	134	166	103	48	92	74.25	81	Not Used	
19.2	74.25	99	166	94	8	91	27	110	48	75
27	48	67	27	109	166	103	74.25	97	Not Used	
48	48	93	27	123	166	137	166	138	8	103

Recommended Crystal Specification

For SMD Package

Parameter	Description	Range 1	Range 2	Range 3	Unit
F _{IN}	Crystal frequency	8–14	14–28	28–48	MHz
R1	Maximum motional resistance (ESR)	135	50	30	Ω
CL	Parallel load capacitance (see Note 3 below)	8–18	8–14	8–12	pF
DL(max)	Maximum crystal drive level	300	300	300	μW

Notes

- Guaranteed by design but not 100% tested.
- Configuration dependent.

Recommended Crystal Specification

For Thru-Hole Package

Parameter ^[5]	Description	Range 1	Range 2	Range 3	Unit
F _{IN}	Crystal frequency	8–14	14–24	24–32	MHz
R1	Maximum motional resistance (ESR)	90	50	30	Ω
CL	Parallel load capacitance (see Note 6 below)	8–18	8–12	8–12	pF
DL(max)	Maximum crystal drive level	1000	1000	1000	μW

Test and Measurement Setup

Figure 3. Test and Measurement Setup

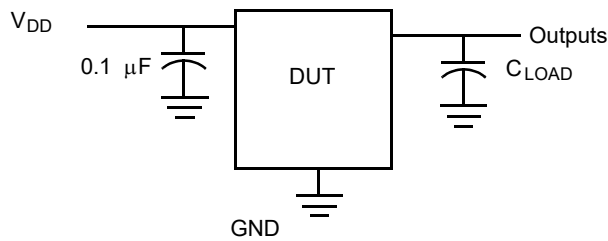

Voltage and Timing Definitions

Figure 4. Duty Cycle Definition

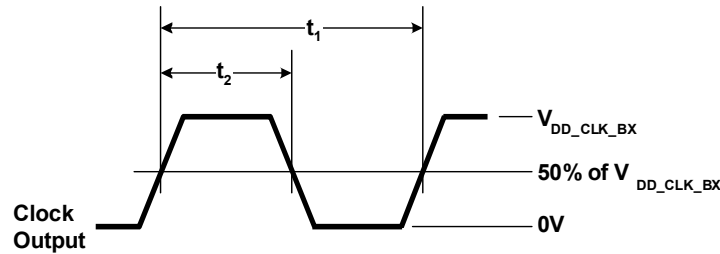
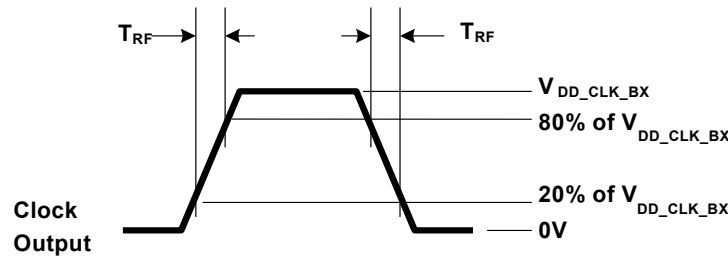

Figure 5. Rise Time = T_{RF}, Fall Time = T_{RF}



Notes

- CY2544, CY2548 and CY2546 have internal crystal load capacitance (CL) adjustment feature.
- Guaranteed by design but not 100% tested.

Ordering Information

Part Number	Type ^[7]	Package	Supply Voltage	Operating Range
Pb-free				
CY2544QFC	Field Programmable	24-pin QFN	2.5 V, 3.0 V or 3.3 V	Commercial, 0 °C to 70 °C
CY2544QFCT	Field Programmable	24-pin QFN – Tape and Reel	2.5 V, 3.0 V or 3.3 V	Commercial, 0 °C to 70 °C
CY2544QFI	Field Programmable	24-pin QFN	2.5 V, 3.0 V or 3.3 V	Industrial, –40 °C to +85 °C
CY2544QFIT	Field Programmable	24-pin QFN – Tape and Reel	2.5 V, 3.0 V or 3.3 V	Industrial, –40 °C to +85 °C
CY2548QI	Field Programmable	24-pin QFN	2.5 V, 3.0 V or 3.3 V	Industrial, –40 °C to +85 °C
CY2548QIT	Field Programmable	24-pin QFN – Tape and Reel	2.5 V, 3.0 V or 3.3 V	Industrial, –40 °C to +85 °C
Programmer				
CY3675-CLKMAKER1	Programming kit			
CY3675-QFN24A	Socket adapter board, for programming CY2544 and CY2548 ^[8]			

Some product offerings are factory programmed customer specific devices with customized part numbers. The [Possible Configurations](#) table shows the available device types, but not complete part numbers. Contact your local Cypress FAE or sales representative for more information.

Possible Configurations

Part Number ^[9]	Type ^[7]	Package	Supply Voltage	Operating Range
Pb-free				
CY2544QCxxx	Factory Programmed	24-pin QFN	2.5 V, 3.0 V or 3.3 V	Commercial, 0 °C to 70 °C
CY2544QCxxxT	Factory Programmed	24-pin QFN – Tape and Reel	2.5 V, 3.0 V or 3.3 V	Commercial, 0 °C to 70 °C
CY2548QCxxx	Factory Programmed	24-pin QFN	2.5 V, 3.0 V or 3.3 V	Commercial, 0 °C to 70 °C
CY2548QCxxxT	Factory Programmed	24-pin QFN – Tape and Reel	2.5 V, 3.0 V or 3.3 V	Commercial, 0 °C to 70 °C
CY2546QCxxx	Factory Programmed	24-pin QFN	1.8 V	Commercial, 0 °C to 70 °C
CY2546QCxxxT	Factory Programmed	24-pin QFN – Tape and Reel	1.8 V	Commercial, 0 °C to 70 °C
CY2544QIxxx	Factory Programmed	24-pin QFN	2.5 V, 3.0 V or 3.3 V	Industrial, –40 °C to +85 °C
CY2544QIxxxT	Factory Programmed	24-pin QFN – Tape and Reel	2.5 V, 3.0 V or 3.3 V	Industrial, –40 °C to +85 °C
CY2548QIxxx	Factory Programmed	24-pin QFN	2.5 V, 3.0 V or 3.3 V	Industrial, –40 °C to +85 °C
CY2548QIxxxT	Factory Programmed	24-pin QFN – Tape and Reel	2.5 V, 3.0 V or 3.3 V	Industrial, –40 °C to +85 °C
CY2546QIxxx	Factory Programmed	24-pin QFN	1.8 V	Industrial, –40 °C to +85 °C
CY2546QIxxxT	Factory Programmed	24-pin QFN – Tape and Reel	1.8 V	Industrial, –40 °C to +85 °C

Notes

- Field Programmable devices are shipped unprogrammed, and must be programmed before being installed on a board. Factory Programmed devices are shipped fully configured and ready to install on a board.
- The CY3675-QFN24A cannot be used to program the CY2546.
- “xxx” is a variable that denotes a specific device configuration. For more details, contact your local Cypress FAE or sales representative.

Ordering Code Definitions

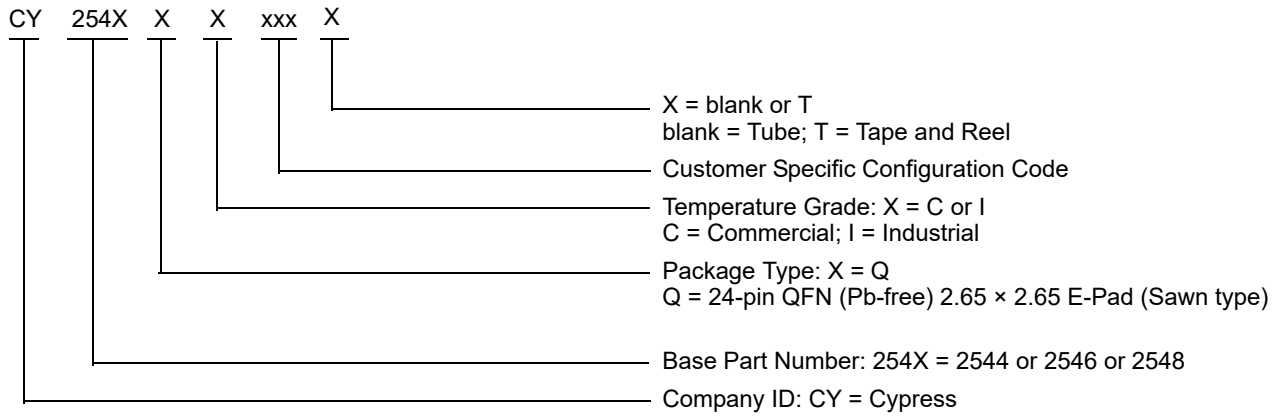

Package Drawing and Dimensions

Figure 6. 24-pin QFN (4 × 4 × 0.55 mm) LQ24A 2.65 × 2.65 E-Pad (Sawn) Package Outline, 001-13937

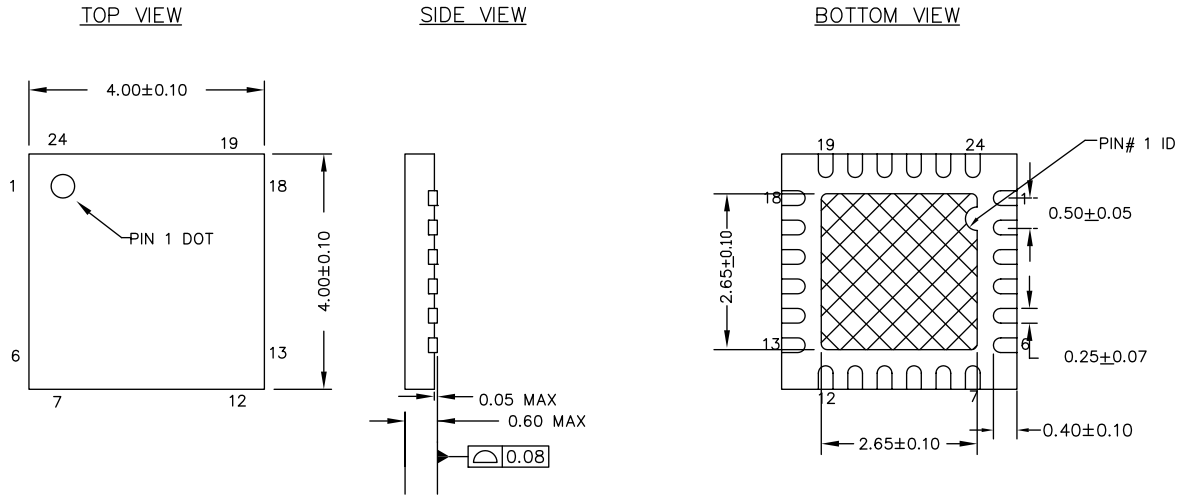

NOTES :

1.  HATCH IS SOLDERABLE EXPOSED METAL.
2. REFERENCE JEDEC # MO-248
3. PACKAGE WEIGHT : 29 ± 3 mg
4. ALL DIMENSIONS ARE IN MILLIMETERS

001-13937 *F

Acronyms

Acronym	Description
DL	Drive Level
DNU	Do Not Use
DUT	Device Under Test
EIA	Electronic Industries Alliance
EMI	Electromagnetic Interference
ESD	Electrostatic Discharge
FAE	Field Application Engineer
FS	Frequency Select
JEDEC	Joint Electron Devices Engineering Council
LVC MOS	Low Voltage Complimentary Metal Oxide Semiconductor
OE	Output Enable
OSC	Oscillator
PD	Power Down
PLL	Phase-Locked Loop
PPM	Parts Per Million
SS	Spread Spectrum
SSC	Spread Spectrum Clock
SSON	Spread Spectrum On

Document Conventions

Units of Measure

Symbol	Unit of Measure
°C	degree Celsius
fF	femtofarad
MHz	megahertz
μs	microsecond
μW	microwatt
mA	milliampere
ms	millisecond
ns	nanosecond
Ω	ohm
ppm	parts per million
pF	picofarad
ps	picosecond
V	volt
W	watt

Document History Page

Document Title: CY2544/CY2546/CY2548, Quad-PLL Programmable Clock Generator with Spread Spectrum Document Number: 001-12563				
Revision	ECN	Orig. of Change	Submission Date	Description of Change
**	690257	RGL	01/17/2007	New data sheet.
*A	790516	RGL	02/20/2007	Separated the Pin Configuration drawing into two to show the difference between CY2544 and CY2546 pinouts. Updated DC Electrical Specifications : Updated Test Conditions of I _{ILPDOE} parameter (Replaced "Internal pull up = 100k typical" with "No Internal pull up"). Changed maximum value of I _{ILPDOE} parameter from 10 μA to 1 μA. Updated Test Conditions of I _{IHPDOE} parameter (Replaced "Internal pull up = 100k typical" with "No Internal pull up"). Updated Test Conditions of I _{ILSR} parameter (Replaced "Internal pull down = 100k typical" with "Internal pull down = 160k typical"). Updated Test Conditions of I _{IHSR} parameter (Replaced "Internal pull down = 100k typical" with "Internal pull down = 160k typical"). Changed the maximum value of I _{IHSR} parameter from 10 μA to 25 μA. Removed maximum value of I _{DD} parameter (22 mA). Added typical value of I _{DD} parameter (15 mA).
*B	1508943	RGL / AESA	10/03/2007	Changed status from Preliminary to Final. Added Device Selection Guide . Updated Absolute Maximum Conditions : Changed condition of ESD _{HBM} parameter from "MIL-STD-883, Method 3015" to "JEDEC EIA/JESD22-A114-E". Updated DC Electrical Specifications : Removed V _{IL} , V _{IH} , V _{ILX} , V _{IHX} parameters and their details. Added V _{IL1} , V _{IH1} , V _{IL2} , V _{IH2} , V _{IL3} , V _{IH3} , V _{IL4} , V _{IH4} , V _{IL5} , V _{IH5} parameters and their details. Renamed I _{ILPDOE} parameter as I _{IL1} , updated test conditions and changed maximum value of the same parameter from 1 μA to 10 μA. Renamed I _{IHPDOE} parameter as I _{IH1} , updated test conditions and changed maximum value of the same parameter from 1 μA to 10 μA. Renamed I _{ILSR} parameter as I _{IL2} and changed maximum value of the same parameter from 1 μA to 10 μA. Renamed I _{IHSR} parameter as I _{IH2} , changed maximum value of the same parameter from 25 μA to 36 μA and also added minimum value of the same parameter as 14 μA. Added R _{DN} parameter and its details. Changed typical value of I _{DDS} value from 50 μA to 3 μA. Updated AC Electrical Specifications : Added T _{RF1} , T _{RF2} , T _{RF3} , T _{RF4} parameters and their details. Renamed T _{CCJ1} parameter as T _{CCJ} and added typical value. Removed T _{LTJ} parameter and its details. Updated Configuration Example for C-C Jitter : Removed details of "Long Term Jitter". Updated details corresponding to "Cycle-to-Cycle Jitter". Updated Recommended Crystal Specification : Removed C0 parameter and its details. Updated Recommended Crystal Specification : Removed C0 parameter and its details. Updated Ordering Information : Deleted generic part numbers.
*C	2748211	TSAI	08/10/2009	Post to external web.
*D	2764011	CXQ	09/15/2009	Updated Ordering Information : Fixed typo (Changed CY2548Cxxx and CY2548CxxxT to CY2548lxxx and CY2548lxxxT for industrial temp parts).

Document History Page (continued)

Document Title: CY2544/CY2546/CY2548, Quad-PLL Programmable Clock Generator with Spread Spectrum Document Number: 001-12563				
Revision	ECN	Orig. of Change	Submission Date	Description of Change
*E	2899758	KVM	03/26/2010	Updated Ordering Information : Updated part numbers. Updated Package Drawing and Dimensions . Updated copyright section.
*F	2969587	KVM	07/09/2010	Minor change: Added "with Spread Spectrum" in first page title to match spec title on the first page with spec title on the document history page.
*G	3115710	BASH	12/21/2010	Added Ordering Code Definitions under Ordering Information . Added Acronyms and Units of Measure .
*H	4239875	CINM	01/08/2014	Updated Package Drawing and Dimensions : spec 51-85203 – Changed revision from *B to *D. Updated to new template. Completing Sunset Review.
*I	4586478	AJU	03/12/2014	Updated Functional Description : Added "For a complete list of related documentation, click here ." at the end.
*J	5208624	PSR	04/06/2016	Updated Ordering Information : Updated part numbers. Updated Ordering Code Definitions . Updated Package Drawing and Dimensions : Added spec 001-13937 *F (Figure 6). Updated to new template.
*K	5563470	PSR	12/22/2016	Updated Ordering Information : Updated part numbers. Updated Possible Configurations : Updated part numbers. Updated Ordering Code Definitions . Updated Package Drawing and Dimensions : Removed spec 51-85203 *D. Updated to new template. Completing Sunset Review.
*L	5778002	PSR	06/19/2017	Updated Features : Added one-time programmability. Updated Pin Definitions : Updated details in "Description" column corresponding to pin numbers 2, 6, 11, 13, 17, and 20. Updated Pin Definitions : Updated details in "Description" column corresponding to pin numbers 2, 6, 11, 13, 17, and 20. Updated Functional Overview : Added Output Driver Supply and Multi-Function Input Restriction . Updated to new template.
*M	5952620	XHT	10/31/2017	Updated DC Electrical Specifications : Updated details in "Max" column corresponding to V_{IL2} , V_{IL3} , V_{IL4} , and V_{IL5} parameters. Updated details in "Min" column corresponding to V_{IH2} , V_{IH4} , and V_{IH5} parameters. Updated to new template.

Sales, Solutions, and Legal Information

Worldwide Sales and Design Support

Cypress maintains a worldwide network of offices, solution centers, manufacturers' representatives, and distributors. To find the office closest to you, visit us at [Cypress Locations](#).

Products

ARM® Cortex® Microcontrollers	cypress.com/arm
Automotive	cypress.com/automotive
Clocks & Buffers	cypress.com/clocks
Interface	cypress.com/interface
Internet of Things	cypress.com/iot
Memory	cypress.com/memory
Microcontrollers	cypress.com/mcu
PSoC	cypress.com/psoc
Power Management ICs	cypress.com/pmic
Touch Sensing	cypress.com/touch
USB Controllers	cypress.com/usb
Wireless Connectivity	cypress.com/wireless

PSoC® Solutions

[PSoC 1](#) | [PSoC 3](#) | [PSoC 4](#) | [PSoC 5LP](#) | [PSoC 6](#)

Cypress Developer Community

[Forums](#) | [WICED IOT Forums](#) | [Projects](#) | [Video](#) | [Blogs](#) | [Training](#) | [Components](#)

Technical Support

cypress.com/support

© Cypress Semiconductor Corporation, 2007-2017. This document is the property of Cypress Semiconductor Corporation and its subsidiaries, including Spansion LLC ("Cypress"). This document, including any software or firmware included or referenced in this document ("Software"), is owned by Cypress under the intellectual property laws and treaties of the United States and other countries worldwide. Cypress reserves all rights under such laws and treaties and does not, except as specifically stated in this paragraph, grant any license under its patents, copyrights, trademarks, or other intellectual property rights. If the Software is not accompanied by a license agreement and you do not otherwise have a written agreement with Cypress governing the use of the Software, then Cypress hereby grants you a personal, non-exclusive, nontransferable license (without the right to sublicense) (1) under its copyright rights in the Software (a) for Software provided in source code form, to modify and reproduce the Software solely for use with Cypress hardware products, only internally within your organization, and (b) to distribute the Software in binary code form externally to end users (either directly or indirectly through resellers and distributors), solely for use on Cypress hardware product units, and (2) under those claims of Cypress's patents that are infringed by the Software (as provided by Cypress, unmodified) to make, use, distribute, and import the Software solely for use with Cypress hardware products. Any other use, reproduction, modification, translation, or compilation of the Software is prohibited.

TO THE EXTENT PERMITTED BY APPLICABLE LAW, CYPRESS MAKES NO WARRANTY OF ANY KIND, EXPRESS OR IMPLIED, WITH REGARD TO THIS DOCUMENT OR ANY SOFTWARE OR ACCOMPANYING HARDWARE, INCLUDING, BUT NOT LIMITED TO, THE IMPLIED WARRANTIES OF MERCHANTABILITY AND FITNESS FOR A PARTICULAR PURPOSE. To the extent permitted by applicable law, Cypress reserves the right to make changes to this document without further notice. Cypress does not assume any liability arising out of the application or use of any product or circuit described in this document. Any information provided in this document, including any sample design information or programming code, is provided only for reference purposes. It is the responsibility of the user of this document to properly design, program, and test the functionality and safety of any application made of this information and any resulting product. Cypress products are not designed, intended, or authorized for use as critical components in systems designed or intended for the operation of weapons, weapons systems, nuclear installations, life-support devices or systems, other medical devices or systems (including resuscitation equipment and surgical implants), pollution control or hazardous substances management, or other uses where the failure of the device or system could cause personal injury, death, or property damage ("Unintended Uses"). A critical component is any component of a device or system whose failure to perform can be reasonably expected to cause the failure of the device or system, or to affect its safety or effectiveness. Cypress is not liable, in whole or in part, and you shall and hereby do release Cypress from any claim, damage, or other liability arising from or related to all Unintended Uses of Cypress products. You shall indemnify and hold Cypress harmless from and against all claims, costs, damages, and other liabilities, including claims for personal injury or death, arising from or related to any Unintended Uses of Cypress products.

Cypress, the Cypress logo, Spansion, the Spansion logo, and combinations thereof, WICED, PSoC, CapSense, EZ-USB, F-RAM, and Traveo are trademarks or registered trademarks of Cypress in the United States and other countries. For a more complete list of Cypress trademarks, visit cypress.com. Other names and brands may be claimed as property of their respective owners.

Looking for pricing, stock, or lifecycle information?

Click below to explore more details on WIN SOURCE:

 [View CY2544C012 on WIN SOURCE](#)

 [Infineon Technologies](#) Information

Optimize Your Supply Chain with WIN SOURCE Solutions

-  Global Sourcing Solution
-  Obsolete Management
-  Cost Control Management
-  Shortage Management
-  Alternative Solution
-  Excess Inventory Management