



**THE DATASHEET OF
CY2309NZSXC-1HT**



Features

- One-input to nine-output buffer/driver
- Supports two DIMMs or four SO-DIMMs with one additional output for feedback to an external or chipset phase-locked loop (PLL)
- Low power consumption for mobile applications
 - Less than 32 mA at 66.6 MHz with unloaded outputs
- 1-ns input-output delay
- Buffers all frequencies from 2 MHz to 133.33 MHz
- Output-output skew less than 250 ps
- Multiple V_{DD} and V_{SS} pins for noise and electromagnetic interference (EMI) reduction
- Space-saving 16-pin 150-mil small-outline integrated circuit (SOIC) package
- 3.3-V operation
- Industrial temperature available

Functional Description

The CY2309NZ is a low-cost buffer designed to distribute high-speed clocks in mobile PC systems and desktop PC systems with SDRAM support. The part has nine outputs, eight of which can be used to drive two DIMMs or four SO-DIMMs, and the remaining can be used for external feedback to a PLL. The device operates at 3.3 V and outputs can run up to 133.33 MHz.

The CY2309NZ is designed for low EMI and power optimization. It has multiple V_{SS} and V_{DD} pins for noise optimization and consumes less than 32 mA at 66.6 MHz, making it ideal for the low-power requirements of mobile systems. It is available in an ultra-compact 150-mil 16-pin SOIC package.

For a complete list of related documentation, click [here](#).

Logic Block Diagram

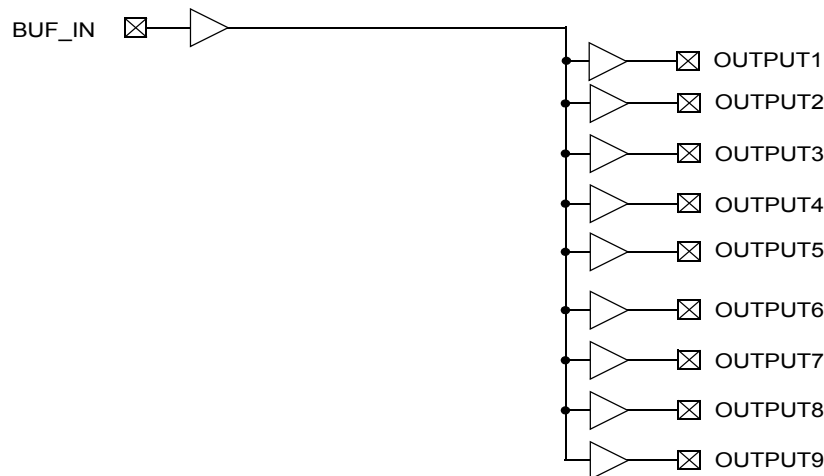

Contents

Pinout	3	Package Diagram	8
Pin Descriptions	3	Acronyms	9
Maximum Ratings	4	Document Conventions	9
Operating Conditions	4	Units of Measure	9
Electrical Characteristics	4	Document History Page	10
Thermal Resistance	4	Sales, Solutions, and Legal Information	11
Switching Characteristics	5	Worldwide Sales and Design Support	11
Switching Waveforms	6	Products	11
Test Circuits	6	PSoC@Solutions	11
Ordering Information	7	Cypress Developer Community	11
Ordering Code Definitions	7	Technical Support	11

Pinout

Figure 1. 16-pin SOIC pinout (Top View)

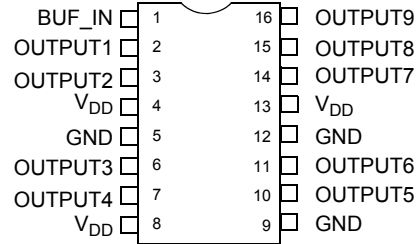

Pin Descriptions

Pin	Signal	Description
4, 8, 13	V _{DD}	3.3-V digital voltage supply
5, 9, 12	GND	Ground
1	BUF_IN	Input clock
2, 3, 6, 7, 10, 11, 14, 15, 16	OUTPUT [1:9]	Outputs

Maximum Ratings

Supply voltage to ground potential	-0.5 V to +7.0 V	Storage temperature	-65 °C to +150 °C
DC input voltage	-0.5 V to 7.0 V	Junction temperature	150 °C
		Static discharge voltage (per MIL-STD-883, Method 3015)	>2,000 V

Operating Conditions

For commercial and industrial temperature devices

Parameter	Description	Min	Max	Unit
V _{DD}	Supply voltage	3.0	3.6	V
T _A	(Ambient operating temperature) commercial	0	70	°C
	(Ambient operating temperature) industrial	-40	85	°C
C _L	Load capacitance, Fout < 100 MHz	-	30	pF
	Load capacitance, 100 MHz < Fout < 133.33 MHz	-	15	pF
C _{IN}	Input capacitance	-	7	pF
BUF_IN, OUTPUT [1:9]	Operating frequency	2	133.33	MHz
t _{PU}	Power-up time for all VDDs to reach minimum specified voltage (power ramps must be monotonic)	0.05	50	ms

Electrical Characteristics

For commercial and industrial temperature devices

Parameter	Description	Test Conditions	Min	Max	Unit
V _{IL}	Input LOW voltage ^[1]		-	0.8	V
V _{IH}	Input HIGH voltage ^[1]		2.0	-	V
I _{IL}	Input LOW current	V _{IN} = 0 V	-	50.0	μA
I _{IH}	Input HIGH current	V _{IN} = V _{DD}	-	100.0	μA
V _{OL}	Output LOW voltage ^[2]	I _{OL} = 8 mA	-	0.4	V
V _{OH}	Output HIGH voltage ^[2]	I _{OH} = -8 mA	2.4	-	V
I _{DD}	Supply current	Unloaded outputs at 66.66 MHz	-	32	mA

Thermal Resistance

Parameter ^[3]	Description	Test Conditions	16-pin SOIC	Unit
θ _{JA}	Thermal resistance (junction to ambient)	Test conditions follow standard test methods and procedures for measuring thermal impedance, in accordance with EIA/JESD51.	111	°C/W
θ _{JC}	Thermal resistance (junction to case)		60	°C/W

Notes

1. BUF_IN input has a threshold voltage of V_{DD}/2.
2. Parameter is guaranteed by design and characterization. It is not 100% tested in production.
3. These parameters are guaranteed by design and are not tested.

Switching Characteristics

For commercial and industrial temperature devices ^[4]

Parameter	Description	Condition	Min	Typ	Max	Unit
	Duty cycle ^[5] = $t_2 \div t_1$	Measured at 1.4 V	40.0	50.0	60.0	%
t ₃	Rise time ^[5]	Measured between 0.8 V and 2.0 V	–	–	1.50	ns
t ₄	Fall time ^[5]	Measured between 0.8 V and 2.0 V	–	–	1.50	ns
t ₅	Output to output skew ^[5]	All outputs equally loaded	–	–	250	ps
t ₆	Propagation delay, BUF_IN Rising edge to Output Rising edge ^[5]	Measured at V _{DD} /2	1	5	9.2	ns

Notes

4. All parameters specified with loaded outputs.
5. Parameter is guaranteed by design and characterization. It is not 100% tested in production.

Switching Waveforms

Figure 2. Duty Cycle Timing

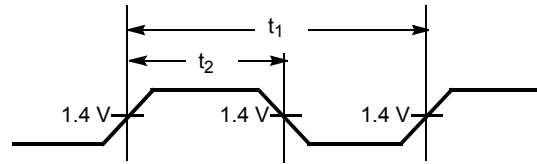

Figure 3. All Outputs Rise/Fall Time

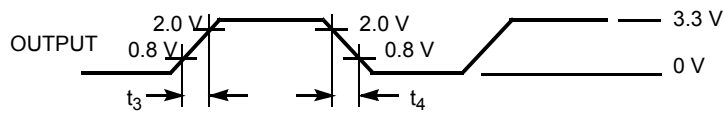

Figure 4. Output-Output Skew

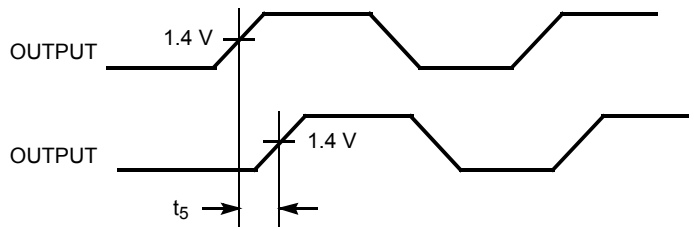
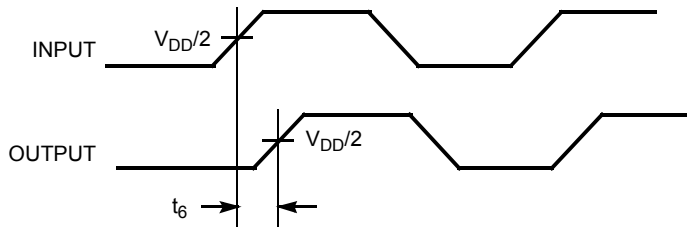
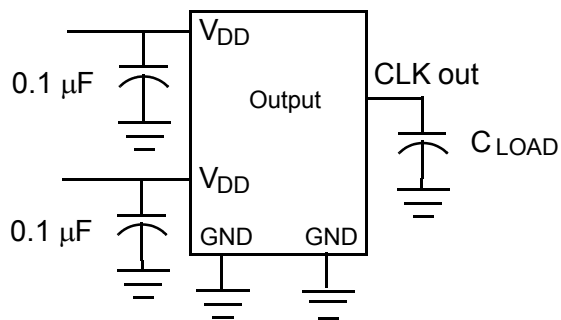

Figure 5. Input-Output Propagation Delay



Test Circuits

Figure 6. Test Circuits



Ordering Information

Ordering Code	Package Type	Operating Range
Pb-free		
CY2309NZSXC-1H	16-pin SOIC (150 Mils)	Commercial
CY2309NZSXC-1HT	16-pin SOIC (150 Mils) – Tape and Reel	Commercial
CY2309NZSXI-1H	16-pin SOIC (150 Mils)	Industrial
CY2309NZSXI-1HT	16-pin SOIC (150 Mils) – Tape and Reel	Industrial

Ordering Code Definitions

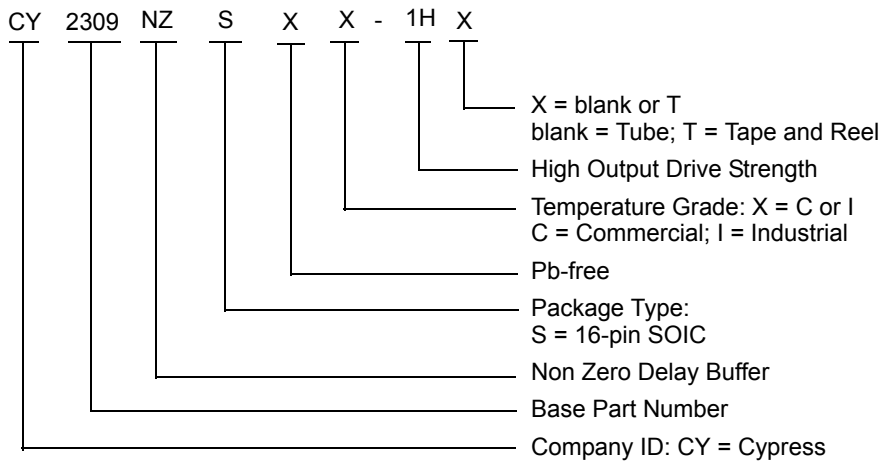

Package Diagram

Figure 7. 16-pin SOIC (150 Mils) S16.15/SZ16.15 Package Outline, 51-85068

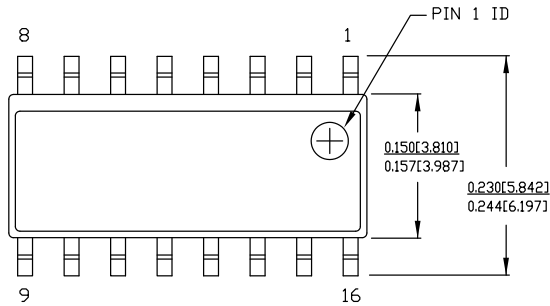

NOTE:

1. DIMENSIONS IN INCHES[MM] **MAX.**
2. REFERENCE JEDEC MS-012
3. PACKAGE WEIGHT : refer to PMDD spec. 001-04308

PART #	
S16.15	STANDARD PKG.
SZ16.15	LEAD FREE PKG.

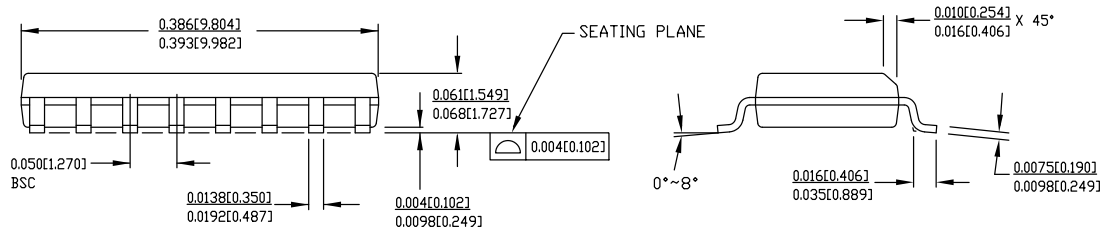

51-85068 *E

Acronyms

Acronym	Description
EMI	Electromagnetic Interference
PLL	Phase-Locked Loop
SOIC	Small-Outline Integrated Circuit

Document Conventions

Units of Measure

Symbol	Unit of Measure
°C	degrees Celsius
MHz	megahertz
μA	microampere
mA	milliampere
ms	millisecond
mV	millivolt
ns	nanosecond
pF	picofarad
V	volt

Document History Page

Document Title: CY2309NZ, Nine-Output 3.3 V Buffer				
Document Number: 38-07182				
Rev.	ECN	Orig. of Change	Submission Date	Description of Change
**	111858	DSG	12/09/01	Change from Spec number: 38-00709 to 38-07182
*A	121834	RBI	12/14/02	Power-up requirements added to Operating Conditions Information
*B	130563	SDR	10/23/03	Added industrial operating temperature to operating conditions
*C	212991	RGL / GGK	03/30/04	Updated the propagation delay T_6 spec to 9.2 ns in the Switching Characteristics table
*D	270149	RGL	10/04/04	Added Lead-free devices Replaced 8.7 ns Input/Output Delay to 1 ns Input/Output Delaying the features section
*E	2568533	AESA	09/23/08	Changed "SDRAM [1:9]" to "OUTPUT [1:9]" in Operating Conditions table. Removed part number CY2309NZSI-1H and CY2309NZSI-1HT. Added Note "Not recommended for new designs." Updated to new template.
*F	2904715	CXQ	04/05/10	Updated Ordering Information : Removed parts CY2309NZSC-1H, CY2309NZSC-1HT. Updated Package Diagram .
*G	3082147	CXQ	11/10/2010	Updated Maximum Ratings : Changed the following from: "DC Input Voltage (Except REF) -0.5 V to VDD + 0.5 V" "DC Input Voltage REF-0.5 V to 7.0 V" to: "DC Input Voltage-0.5 V to 7.0 V" Updated footnotes Added Ordering Code Definitions . Added Acronyms and Units of Measure . Updated to new template.
*H	4201460	CINM	11/25/2013	Updated Package Diagram : spec 51-85068 – Changed revision from *C to *E. Updated to new template. Completing Sunset Review.
*I	4578443	TAVA	11/25/2014	Updated Functional Description : Added "For a complete list of related documentation, click here ." at the end.
*J	4715451	XHT	04/10/2015	Updated Operating Conditions : Updated minimum value of BUF_IN, OUTPUT [1:9] parameter as 5 MHz.
*K	4743611	TAVA	04/27/2015	Updated Operating Conditions : Changed minimum value of BUF_IN, OUTPUT [1:9] parameter from 5 MHz to 2 MHz. Updated to new template.
*L	5260404	PSR	05/05/2016	Added Thermal Resistance . Updated to new template.
*M	5553717	TAVA	12/14/2016	Updated to new template. Completing Sunset Review.

Sales, Solutions, and Legal Information

Worldwide Sales and Design Support

Cypress maintains a worldwide network of offices, solution centers, manufacturer's representatives, and distributors. To find the office closest to you, visit us at [Cypress Locations](#).

Products

ARM® Cortex® Microcontrollers	cypress.com/arm
Automotive	cypress.com/automotive
Clocks & Buffers	cypress.com/clocks
Interface	cypress.com/interface
Internet of Things	cypress.com/iot
Lighting & Power Control	cypress.com/powerpsoc
Memory	cypress.com/memory
PSoC	cypress.com/psoc
Touch Sensing	cypress.com/touch
USB Controllers	cypress.com/usb
Wireless/RF	cypress.com/wireless

PSoC® Solutions

[PSoC 1](#) | [PSoC 3](#) | [PSoC 4](#) | [PSoC 5LP](#)

Cypress Developer Community

[Forums](#) | [Projects](#) | [Video](#) | [Blogs](#) | [Training](#) | [Components](#)

Technical Support

cypress.com/support



© Cypress Semiconductor Corporation, 2001-2016. This document is the property of Cypress Semiconductor Corporation and its subsidiaries, including Spansion LLC ("Cypress"). This document, including any software or firmware included or referenced in this document ("Software"), is owned by Cypress under the intellectual property laws and treaties of the United States and other countries worldwide. Cypress reserves all rights under such laws and treaties and does not, except as specifically stated in this paragraph, grant any license under its patents, copyrights, trademarks, or other intellectual property rights. If the Software is not accompanied by a license agreement and you do not otherwise have a written agreement with Cypress governing the use of the Software, then Cypress hereby grants you a personal, non-exclusive, nontransferable license (without the right to sublicense) (1) under its copyright rights in the Software (a) for Software provided in source code form, to modify and reproduce the Software solely for use with Cypress hardware products, only internally within your organization, and (b) to distribute the Software in binary code form externally to end users (either directly or indirectly through resellers and distributors), solely for use on Cypress hardware product units, and (2) under those claims of Cypress's patents that are infringed by the Software (as provided by Cypress, unmodified) to make, use, distribute, and import the Software solely for use with Cypress hardware products. Any other use, reproduction, modification, translation, or compilation of the Software is prohibited.

TO THE EXTENT PERMITTED BY APPLICABLE LAW, CYPRESS MAKES NO WARRANTY OF ANY KIND, EXPRESS OR IMPLIED, WITH REGARD TO THIS DOCUMENT OR ANY SOFTWARE OR ACCOMPANYING HARDWARE, INCLUDING, BUT NOT LIMITED TO, THE IMPLIED WARRANTIES OF MERCHANTABILITY AND FITNESS FOR A PARTICULAR PURPOSE. To the extent permitted by applicable law, Cypress reserves the right to make changes to this document without further notice. Cypress does not assume any liability arising out of the application or use of any product or circuit described in this document. Any information provided in this document, including any sample design information or programming code, is provided only for reference purposes. It is the responsibility of the user of this document to properly design, program, and test the functionality and safety of any application made of this information and any resulting product. Cypress products are not designed, intended, or authorized for use as critical components in systems designed or intended for the operation of weapons, weapons systems, nuclear installations, life-support devices or systems, other medical devices or systems (including resuscitation equipment and surgical implants), pollution control or hazardous substances management, or other uses where the failure of the device or system could cause personal injury, death, or property damage ("Unintended Uses"). A critical component is any component of a device or system whose failure to perform can be reasonably expected to cause the failure of the device or system, or to affect its safety or effectiveness. Cypress is not liable, in whole or in part, and you shall and hereby do release Cypress from any claim, damage, or other liability arising from or related to all Unintended Uses of Cypress products. You shall indemnify and hold Cypress harmless from and against all claims, costs, damages, and other liabilities, including claims for personal injury or death, arising from or related to any Unintended Uses of Cypress products.

Cypress, the Cypress logo, Spansion, the Spansion logo, and combinations thereof, PSoC, CapSense, EZ-USB, F-RAM, and Traveo are trademarks or registered trademarks of Cypress in the United States and other countries. For a more complete list of Cypress trademarks, visit cypress.com. Other names and brands may be claimed as property of their respective owners.

Looking for pricing, stock, or lifecycle information?

Click below to explore more details on WIN SOURCE:

-  [View CY2309NZSXC-1HT on WIN SOURCE](#)
-  [Cypress Semiconductor Corp Information](#)

Optimize Your Supply Chain with WIN SOURCE Solutions

-  Global Sourcing Solution
-  Obsolete Management
-  Cost Control Management
-  Shortage Management
-  Alternative Solution
-  Excess Inventory Management