



**THE DATASHEET OF
SA620DK,112**



DATA SHEET

SA620

Low voltage LNA, mixer and VCO – 1GHz

Product data
Supersedes data of 1993 Dec 15

2004 Dec 14

1GHz low voltage LNA, mixer and VCO

SA620

DESCRIPTION

The SA620 is a combined RF amplifier, VCO with tracking bandpass filter and mixer designed for high-performance low-power communication systems from 800-1200MHz. The low-noise preamplifier has a 1.6dB noise figure at 900MHz with 11.5dB gain and an IP3 intercept of -3dBm at the input. The gain is stabilized by on-chip compensation to vary less than $\pm 0.2\text{dB}$ over -40 to +85°C temperature range. The wide-dynamic-range mixer has an 9dB noise figure and IP3 of -6dBm at the input at 900MHz. An external LO can be used in place of the internal VCO for improved mixer input IP3 and a 3mA reduction in current. The chip incorporates a through-mode option so the RF amplifier can be disabled and replaced by an attenuator ($S_{21} = -7.5\text{dB}$). This is useful for improving the overall dynamic range of the receiver when in an overload situation. The nominal current drawn from a single 3V supply is 10.4mA and 7.2mA in the thru-mode. Additionally, the VCO and Mixer can be powered down to further reduce the supply current to 1.2mA.

FEATURES

- Low current consumption: 10.4mA nominal, 7.2mA with thru-mode activated
- Outstanding noise figure: 1.6dB for the amplifier and 9dB for the mixer at 900MHz
- Excellent gain stability versus temperature and supply voltage
- Switchable overload capability
- Independent LNA, mixer and VCO power down capability
- Internal VCO automatic leveling loop
- Monotonic VCO frequency vs control voltage

PIN CONFIGURATION

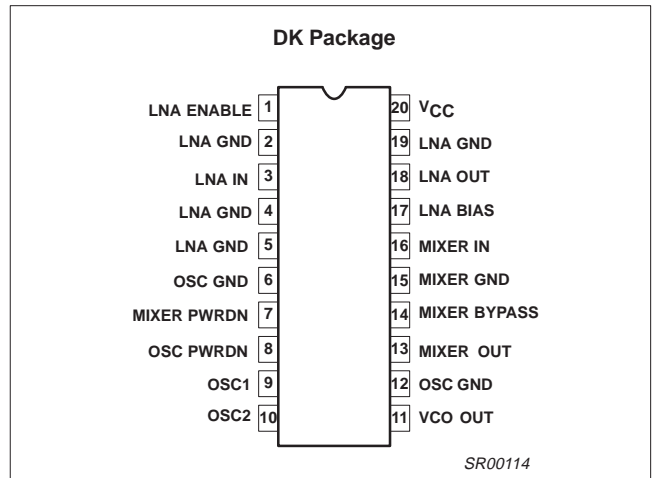

Figure 1. Pin Configuration

APPLICATIONS

- 900MHz cellular front-end
- 900MHz cordless front-end
- Spread spectrum receivers
- RF data links
- UHF frequency conversion
- Portable radio

ORDERING INFORMATION

DESCRIPTION	TEMPERATURE RANGE	ORDER CODE	DWG #
20-Pin Plastic Shrink Small Outline Package (Surface-mount, SSOP)	-40 to +85°C	SA620DK	SOT266-1

BLOCK DIAGRAM

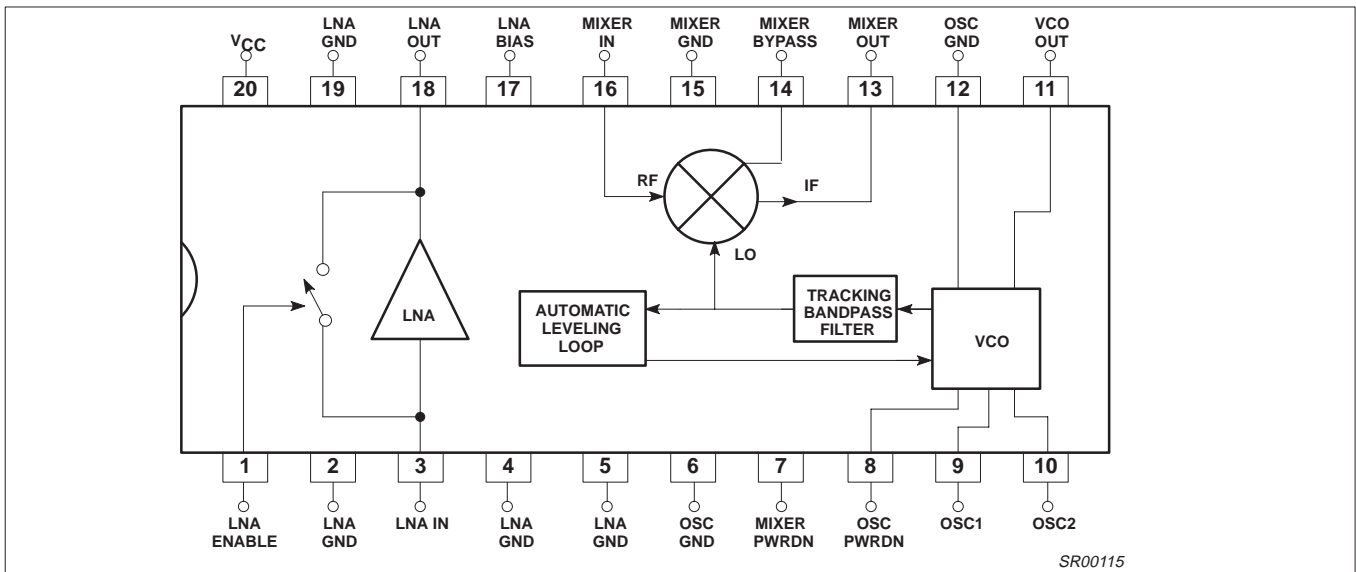

Figure 2. Block Diagram

1GHz low voltage LNA, mixer and VCO

SA620

ABSOLUTE MAXIMUM RATINGS

SYMBOL	PARAMETER	RATING	UNITS
V_{CC}	Supply voltage ¹	-0.3 to +6	V
V_{IN}	Voltage applied to any other pin	-0.3 to ($V_{CC} + 0.3$)	V
P_D	Power dissipation, $T_A = 25^\circ\text{C}$ (still air) ² 20-Pin Plastic SSOP	980	mW
T_{JMAX}	Maximum operating junction temperature	150	$^\circ\text{C}$
P_{MAX}	Maximum power input/output	+20	dBm
T_{STG}	Storage temperature range	-65 to +150	$^\circ\text{C}$

NOTE:

- Transients exceeding 8V on V_{CC} pin may damage product.
- Maximum dissipation is determined by the operating ambient temperature and the thermal resistance,
 θ_{JA} : 20-Pin SSOP = 110 $^\circ\text{C}/\text{W}$

RECOMMENDED OPERATING CONDITIONS

SYMBOL	PARAMETER	RATING	UNITS
V_{CC}	Supply voltage	2.7 to 5.5	V
T_A	Operating ambient temperature range	-40 to +85	$^\circ\text{C}$
T_J	Operating junction temperature	-40 to +105	$^\circ\text{C}$

DC ELECTRICAL CHARACTERISTICS

 $V_{CC} = +3\text{V}$, $T_A = 25^\circ\text{C}$; unless otherwise stated.

SYMBOL	PARAMETER	TEST CONDITIONS	LIMITS			UNITS
			MIN	TYP	MAX	
I_{CC}	Supply current	LNA enable input high		10.4		mA
		LNA enable input low		7.2		mA
		VCO power-down input low		7.4		mA
		Mixer power-down input low		7.4		mA
		Full chip power-down		1.2		mA
V_T	Enable logic threshold voltage ^{NO TAG}		1.2	1.5	1.8	V
V_{IH}	Logic 1 level	RF amp on	2.0		V_{CC}	V
V_{IL}	Logic 0 level	RF amp off	-0.3		0.8	V
I_{IL}	Enable input current	Enable = 0.4V	-1	0	1	μA
I_{IH}	Enable input current	Enable = 2.4V	-1	0	1	μA
V_{LNA-IN}	LNA input bias voltage	Enable = 2.4V		0.78		V
$V_{LNA-OUT}$	LNA output bias voltage	Enable = 2.4V		2.1		V
V_B	LNA bias voltage	Enable = 2.4V		2.1		V
V_{MX-IN}	Mixer RF input bias voltage			0.94		V

NOTE:

- The ENABLE input must be connected to a valid logic level for proper operation of the SA620 LNA.

1GHz low voltage LNA, mixer and VCO

SA620

AC ELECTRICAL CHARACTERISTICS $V_{CC} = +3V$, $T_A = 25^{\circ}C$; Enable = +3V; unless otherwise stated.

SYMBOL	PARAMETER	TEST CONDITIONS	LIMITS			UNITS
			-3 σ	TYP	+3 σ	
S ₂₁	Amplifier gain	900MHz	10	11.5	13	dB
S ₂₁	Amplifier gain in through mode	Enable = 0.4V, 900MHz	-9	-7.5	-6	dB
$\Delta S_{21}/\Delta T$	Gain temperature sensitivity in pwr-dwn mode	900MHz		-0.014		dB/°C
$\Delta S_{21}/\Delta T$	Gain temperature sensitivity enabled	900MHz		0.003		dB/°C
$\Delta S_{21}/\Delta f$	Gain frequency variation	800MHz - 1.2GHz		0.01		dB/MHz
S ₁₂	Amplifier reverse isolation	900MHz		-20		dB
S ₁₁	Amplifier input match ¹	900MHz		-10		dB
S ₂₂	Amplifier output match ¹	900MHz		-12		dB
P _{-1dB}	Amplifier input 1dB gain compression	900MHz		-16		dBm
IP ₃	Amplifier input third order intercept	900MHz	-4.5	-3	-1.5	dBm
NF	Amplifier noise figure	900MHz	1.3	1.6	1.9	dB
t _{ON}	Amplifier turn-on time (Enable Lo → Hi)	See Figure 3		50		μs
t _{OFF}	Amplifier turn-off time (Enable Hi → Lo)	See Figure 3		5		μs
VG _C	Mixer voltage conversion gain: R _P = R _L = 1kΩ,	f _S = 0.9GHz, f _{LO} = 0.8GHz, f _{IF} = 100MHz	14.5	16	17.5	dB
PG _C	Mixer power conversion gain: R _P = R _L = 1kΩ,	f _S = 0.9GHz, f _{LO} = 0.8GHz, f _{IF} = 100MHz	1.5	3	4.5	dB
S _{11M}	Mixer input match ¹	900MHz		-10		dB
NF _M	Mixer SSB noise figure	900MHz	7.5	9	10.5	dB
P _{-1dB}	Mixer input 1dB gain compression	900MHz		-13		dBm
IP _{3M}	Mixer input third order intercept	f ₂ -f ₁ = 1MHz, 900MHz	-7.5	-6	-4.5	dBm
IP _{2INT}	Mixer input second order intercept	900MHz		12		dBm
P _{RFM-IF}	Mixer RF feedthrough	900MHz		-20		dB
P _{LO-IF}	LO feedthrough to IF	900MHz		-25		dBm
P _{LO-RFM}	LO to mixer input feedthrough	900MHz		-30		dBm
P _{LO-RF}	LO to LNA input feedthrough	900MHz		-45		dBm
P _{VCO}	VCO buffer out	900MHz		-16		dBm
	VCO frequency range		300 (min)		1200 (max)	MHz
	VCO phase noise	Offset = 60kHz		-105		dBc/Hz

NOTE:

- Simple L/C elements are needed to achieve specified return loss.

1GHz low voltage LNA, mixer and VCO

SA620

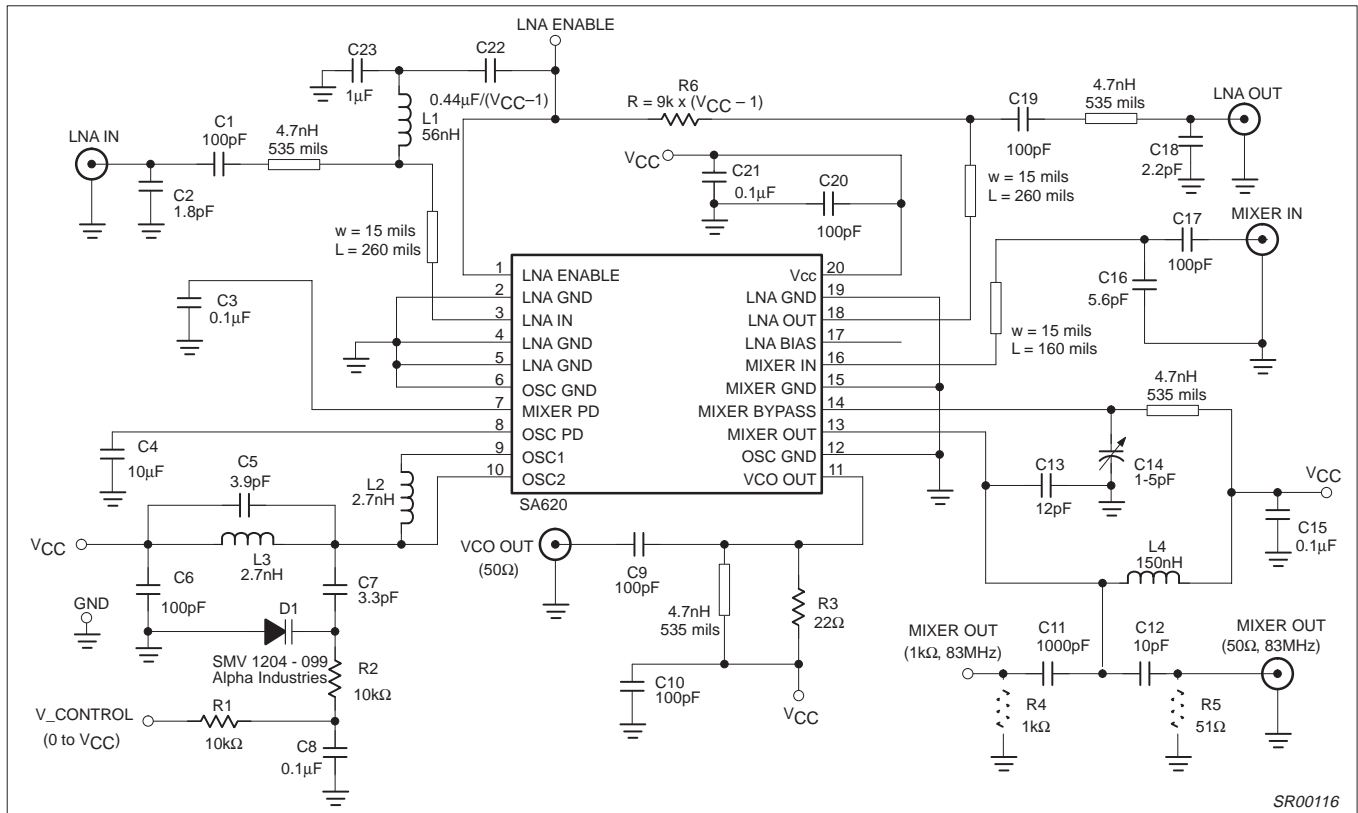

Figure 3. A Complete LNA, Mixer and VCO

CIRCUIT TECHNOLOGY

LNA

Impedance Match: Intrinsic return loss at the input and output ports is 7dB and 9dB, respectively. With no external matching, the associated LNA gain is ≈ 10 dB and the noise figure is ≈ 1.4 dB. However, the return loss can be improved at 900MHz using suggested L/C elements (Figure NO TAG) as the LNA is unconditionally stable.

Noise Match: The LNA achieves 1.6dB noise figure at 900MHz when $S_{11} = -10$ dB. Further improvements in S_{11} will slightly increase the NF and S_{21} .

Thru-Mode: A series switch can be activated to feed RF signals from LNA input to output with an attenuator ($S_{21} = -7.5$ dB). As a result, the power handling is greatly improved and current consumption is decreased by 3.2mA as well. However, if this mode is not required, C23 and R6 can be deleted.

Temperature Compensation: The LNA has a built-in temperature compensation scheme to reduce the gain drift to 0.003dB/°C from -40°C to $+85^{\circ}\text{C}$.

Supply Voltage Compensation: Unique circuitry provides gain stabilization over wide supply voltage range. The gain changes no more than 0.5dB when V_{CC} increases from 3V to 5V.

Mixer

Input Match: The mixer is configured for maximum gain and best noise figure. The user needs to supply L/C elements to achieve this performance.

Mixer Bypass: To optimize the IP3 of the mixer input, one must adjust the value of C14 for the given board layout. The value

typically lies between 1 and 5pF. Once a value is selected, a fixed capacitor can be used. Further improvements in mixer IP3 can be achieved by inserting a resistive loss at the mixer input, at the expense of system gain and noise figure.

Tracking Bandpass Filter: At the LO input port of the mixer there is a second-order bandpass filter (approx. 50MHz bandwidth) which will track the VCO center frequency. The result is the elimination of low frequency noise injected into the mixer LO port without the need for an external LO filter.

Power Down: The mixer can be disabled by connecting Pin 7 to ground. If a Schottky diode is connected between Pin 1 (cathode) and Pin 7 (anode), the LNA disable signal will control both LNA and mixer simultaneously. When the mixer is disabled, 3mA is saved.

Test Port: Resistor R5 can be substituted with an external test port of 50Ω input impedance. Since R5 and MIXER OUT have the same output power, the result is a direct power gain measurement.

VCO

Automatic Leveling Loop: An on-chip detector and loop amplifier will adjust VCO bias current to regulate the VCO amplitude regardless of the Q-factor (>10) of the resonator and varactor diode. However, the real current reduction will not occur until the VCO frequency falls below 500MHz. For a typical resonator the steady-state current is 3mA at 800MHz.

Buffered VCO Output: The VCO OUT (Pin 11) signal can drive an external prescaler directly (see also the Philips SA7025 low voltage, fractional-N synthesizer). The extracted signal levels need to be limited to -16 dBm or less to maintain mixer IIP3.

1GHz low voltage LNA, mixer and VCO

SA620

Phase Noise: If close-in phase noise is not critical, or if an external synthesizer is used, C4 (Pin 8) can be decreased to a lower value.

Power-Down: The VCO can be disabled by connecting Pin 8 to ground. If a Schottky diode is connected between Pin 1 (cathode)

and Pin 8 (anode), the LNA disable signal will control both LNA and VCO simultaneously. When the VCO is disabled, 3mA is saved.

TYPICAL PERFORMANCE CHARACTERISTICS

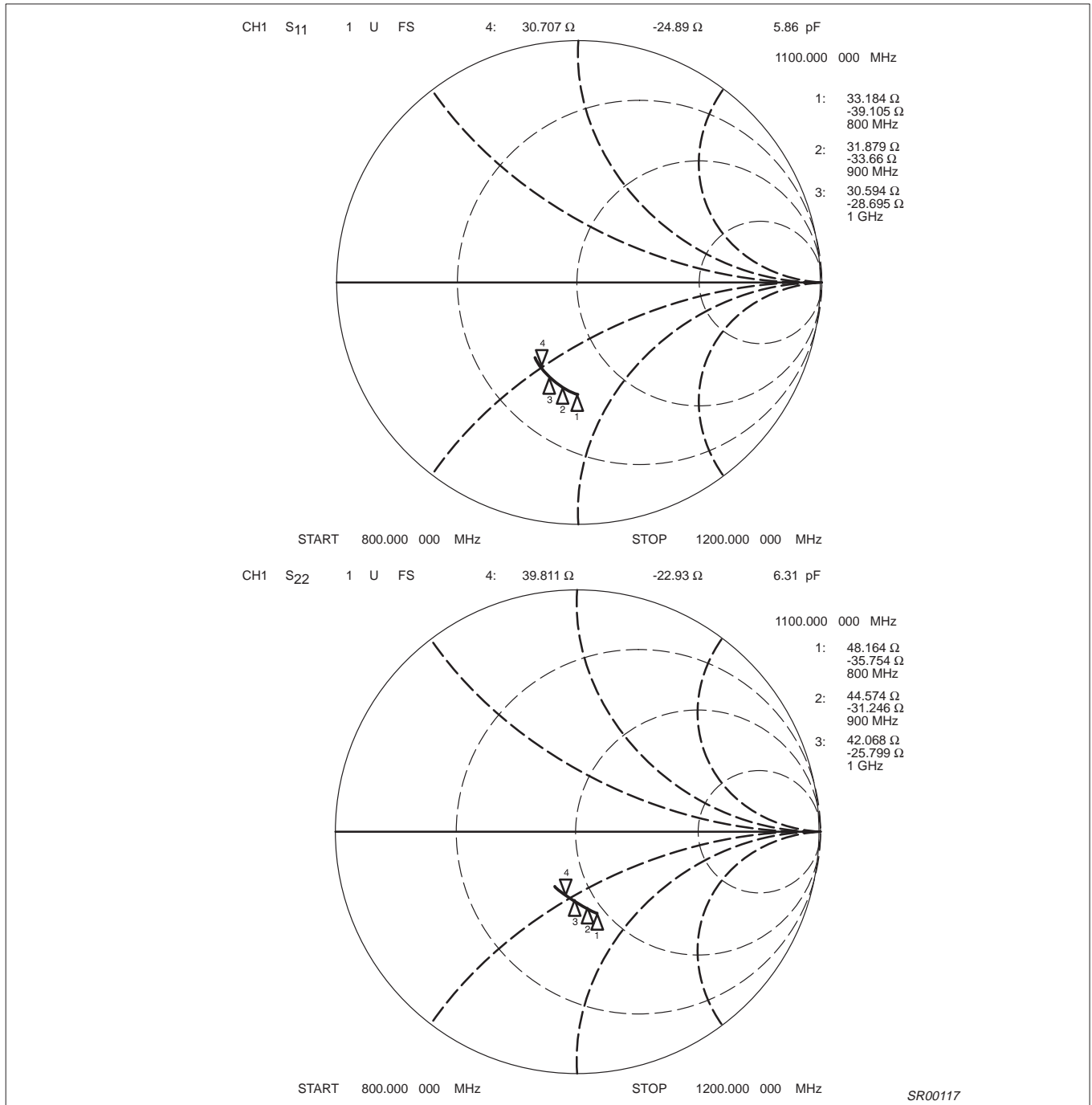

Figure 4. LNA Input and Output Match (at Device Pin)

1GHz low voltage LNA, mixer and VCO

SA620

TYPICAL PERFORMANCE CHARACTERISTICS (Continued)

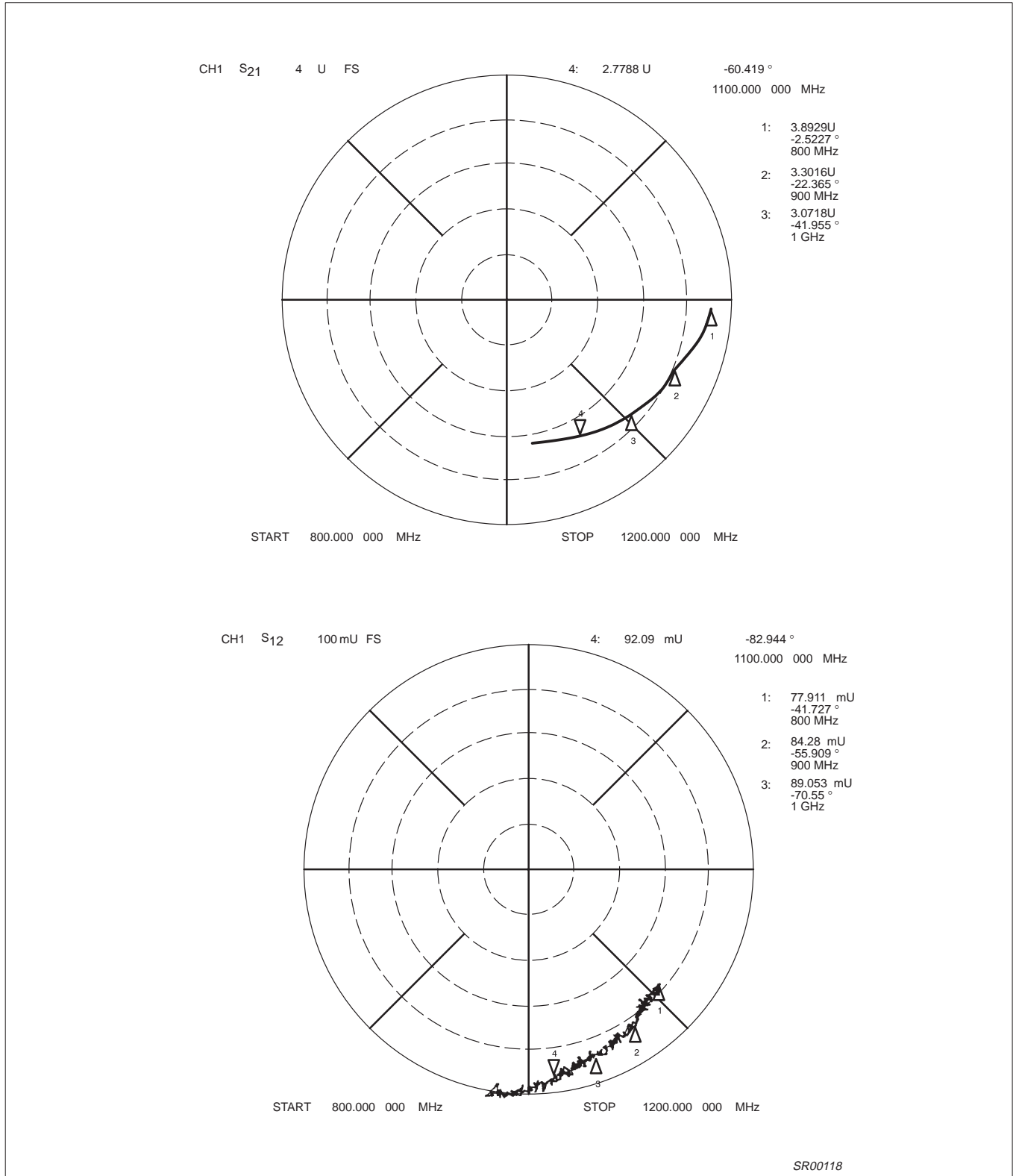

Figure 5. LNA Transmission and Isolation Characteristics (at Device Pin)

1GHz low voltage LNA, mixer and VCO

SA620

TYPICAL PERFORMANCE CHARACTERISTICS (Continued)

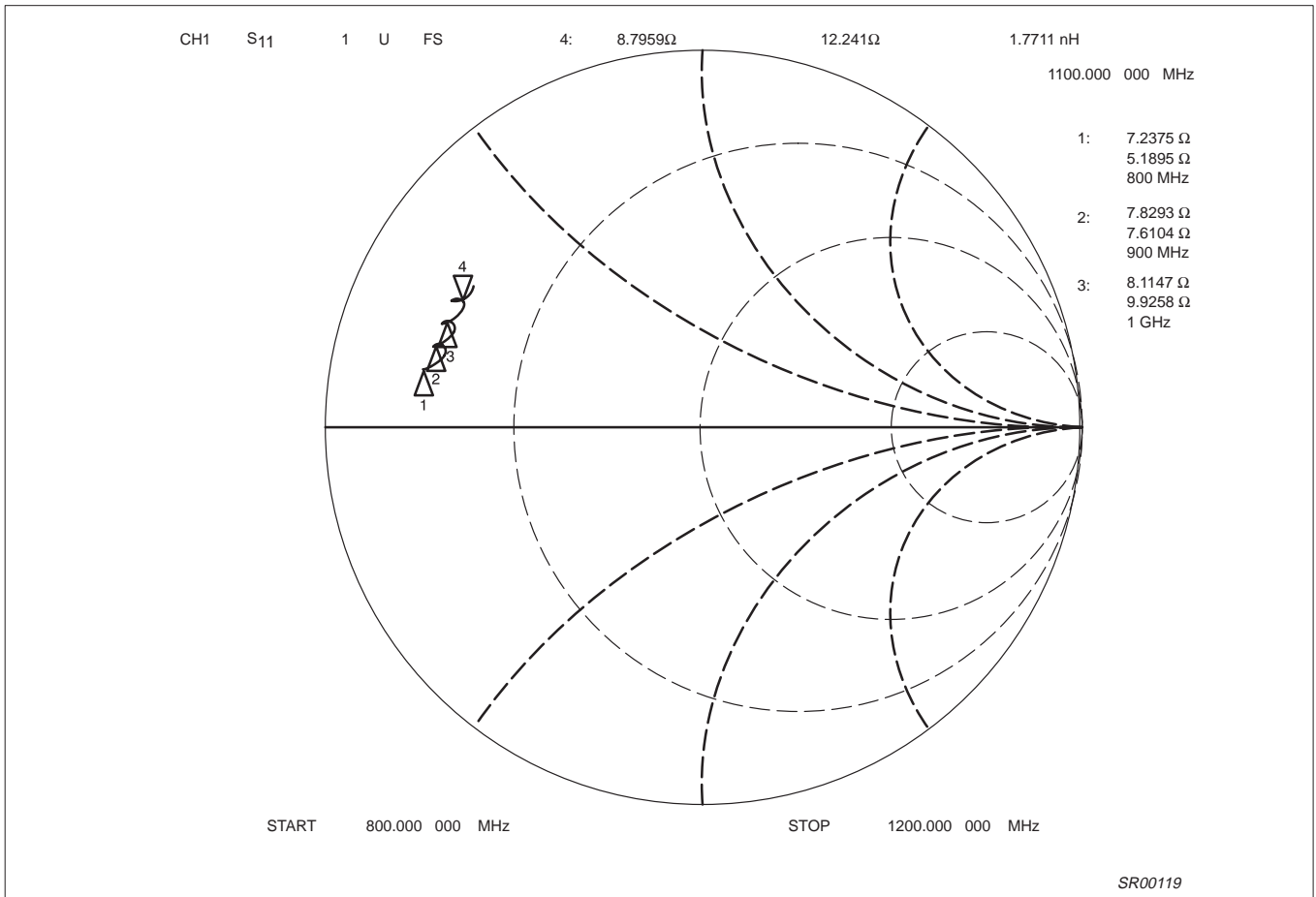

Figure 6. Mixer RF Input Match (at Device Pin)

1GHz low voltage LNA, mixer and VCO

SA620

TYPICAL PERFORMANCE CHARACTERISTICS (Continued)

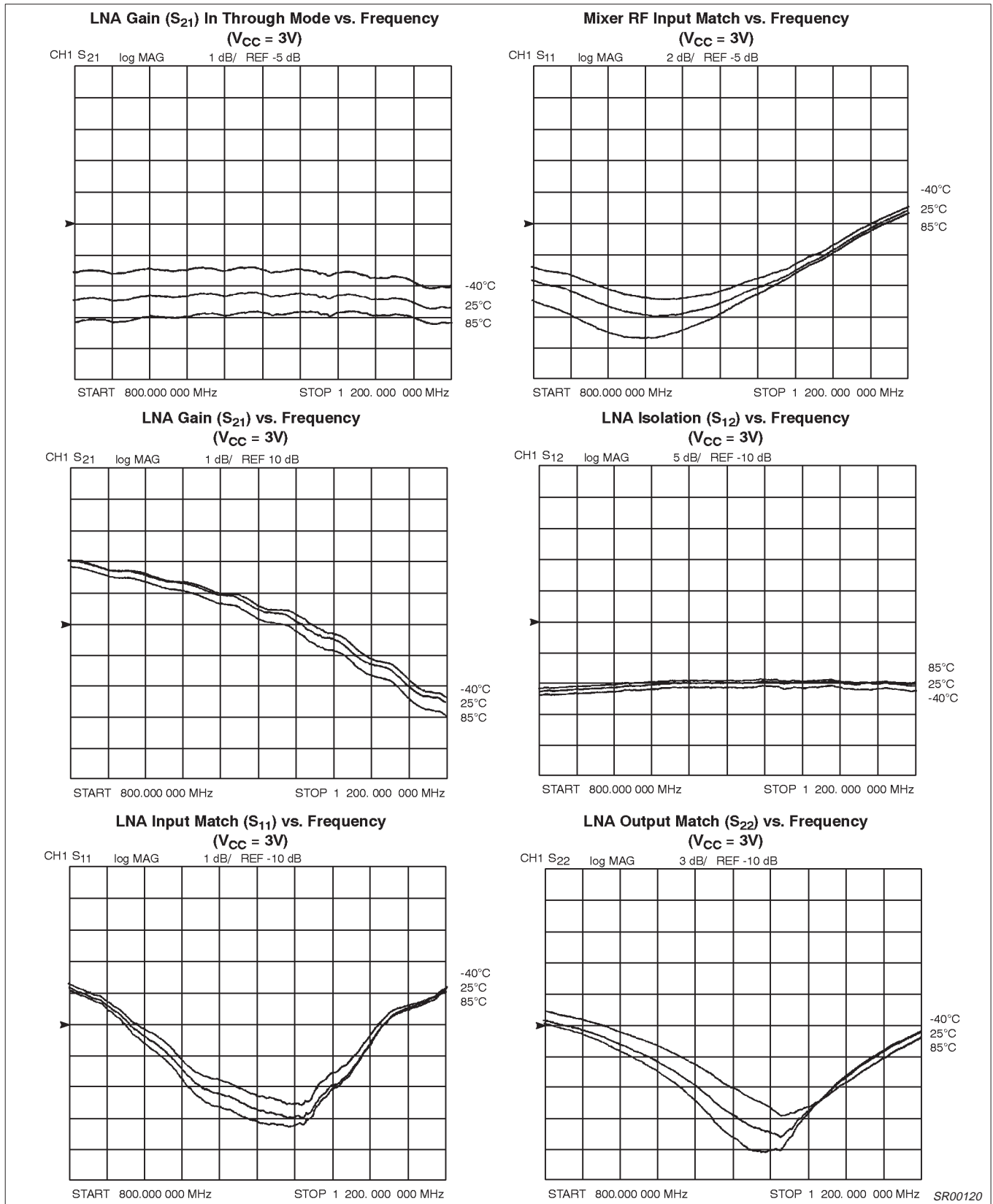

Figure 7. Typical Performance Characteristics (cont.)

1GHz low voltage LNA, mixer and VCO

SA620

TYPICAL PERFORMANCE CHARACTERISTICS (Continued)

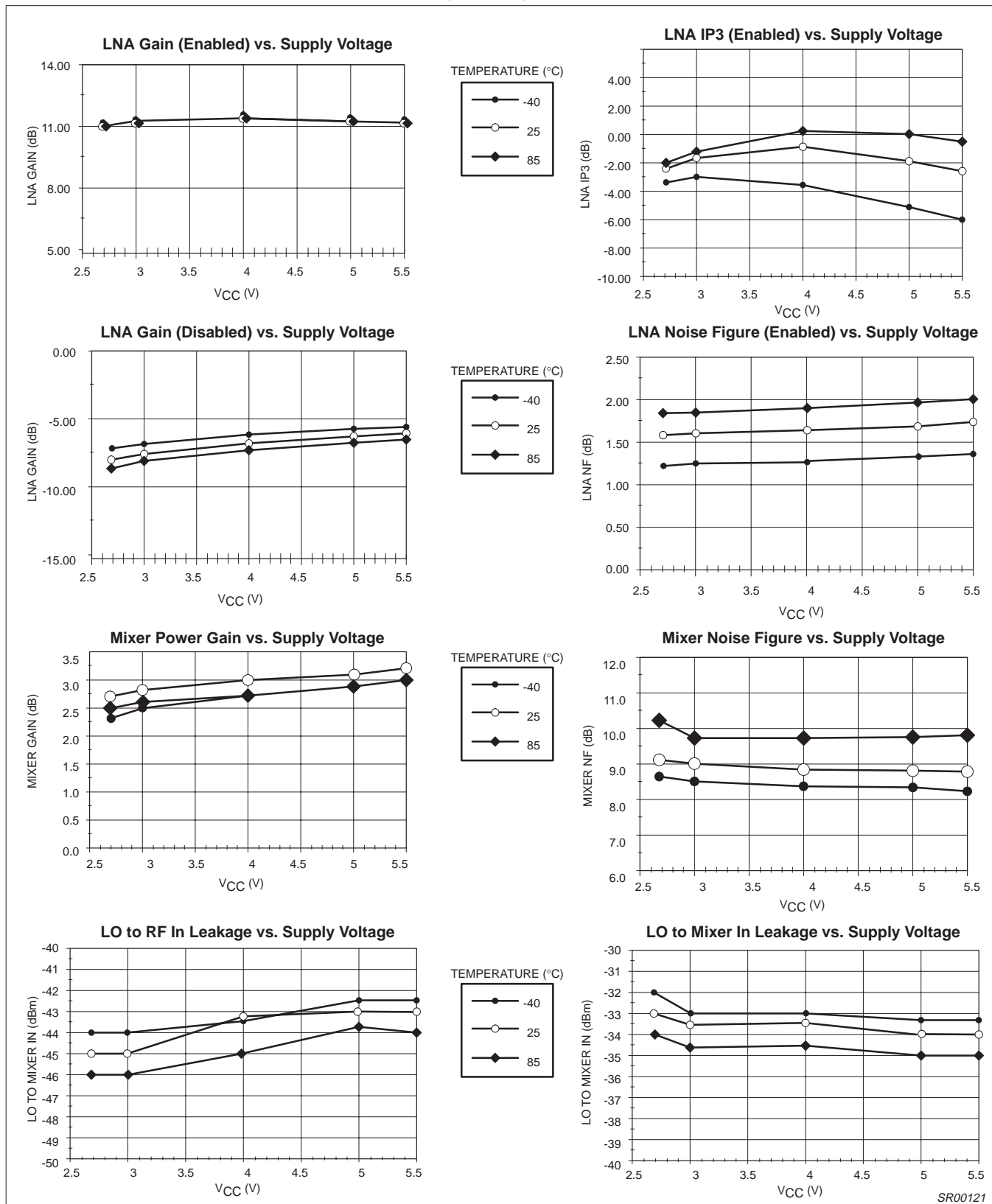

Figure 8. Typical Performance Characteristics (cont.)

SR00121

1GHz low voltage LNA, mixer and VCO

SA620

TYPICAL PERFORMANCE CHARACTERISTICS (Continued)

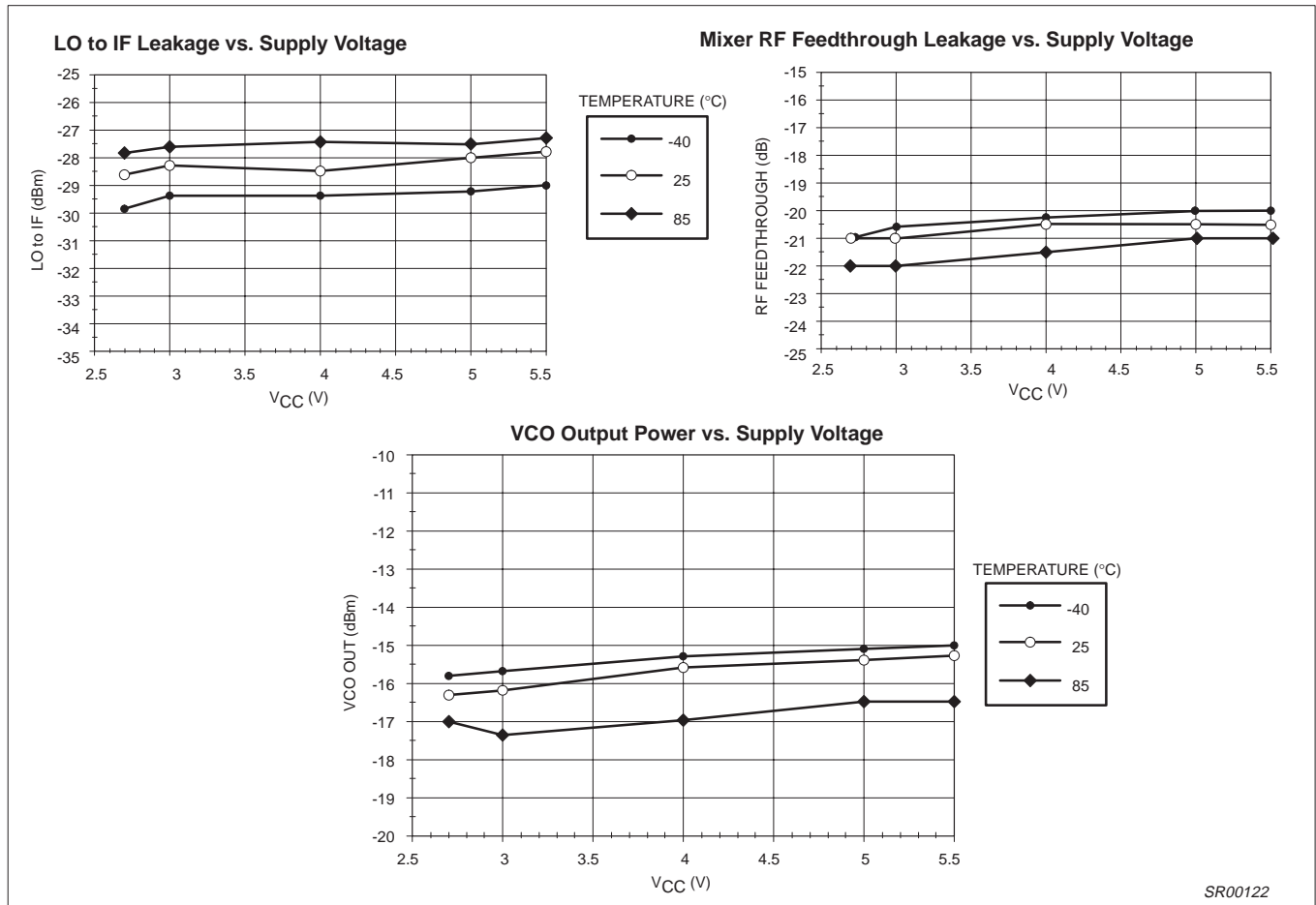
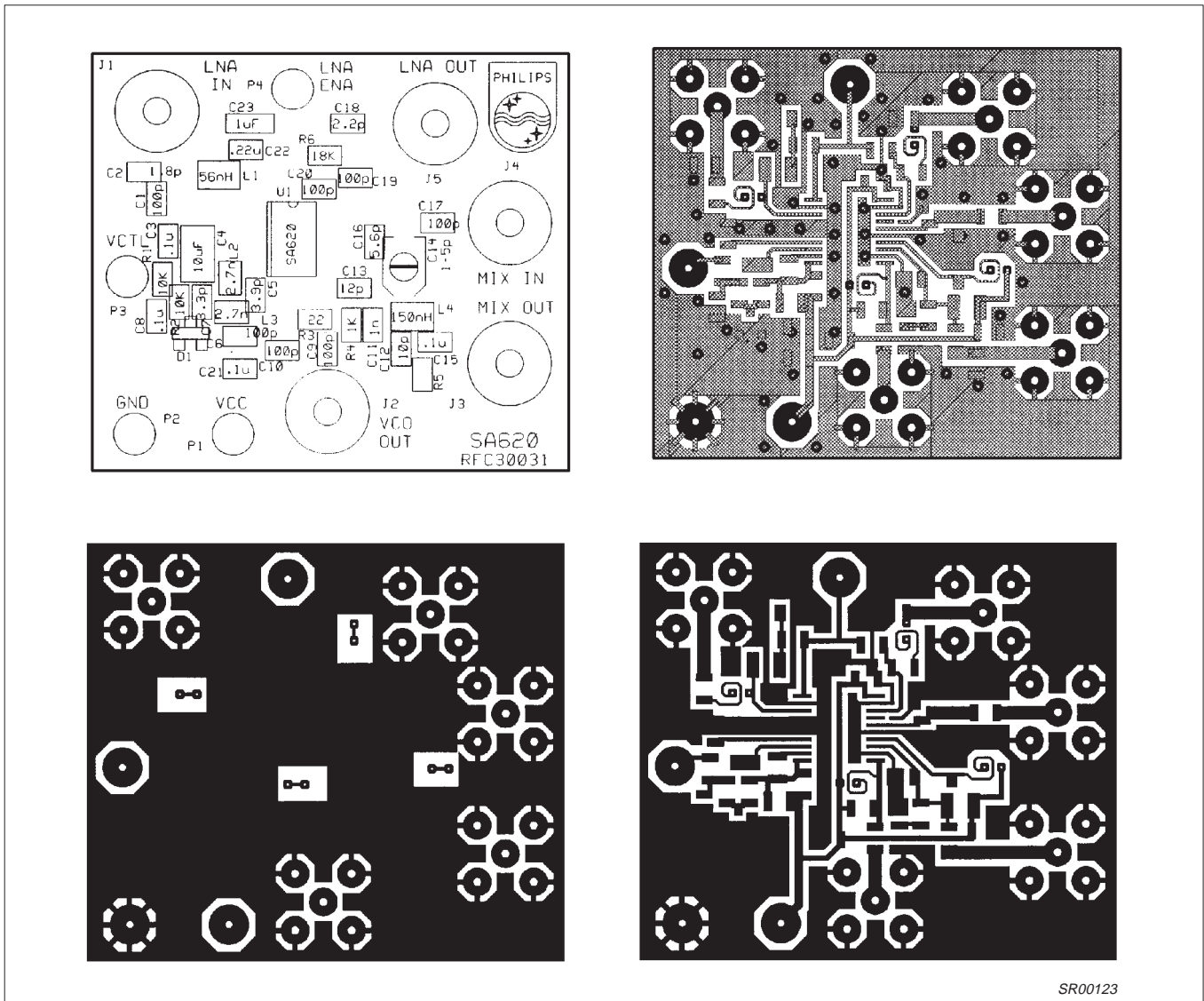

Figure 9. Typical Performance Characteristics (cont.)

1GHz low voltage LNA, mixer and VCO

SA620



1GHz low voltage LNA, mixer and VCO

SA620

SSOP20: plastic shrink small outline package; 20 leads; body width 4.4 mm

SOT266-1

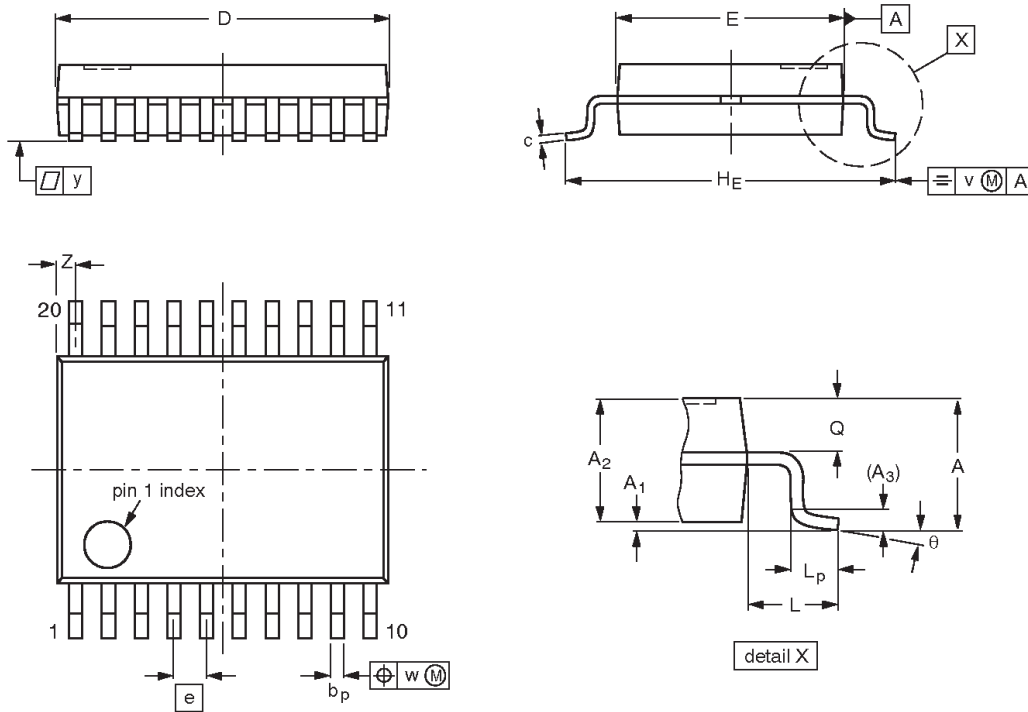

DIMENSIONS (mm are the original dimensions)

UNIT	A max.	A ₁	A ₂	A ₃	b _p	c	D ⁽¹⁾	E ⁽¹⁾	e	HE	L	L _p	Q	v	w	y	Z ⁽¹⁾	θ
mm	1.5	0.15 0	1.4 1.2	0.25	0.32 0.20	0.20 0.13	6.6 6.4	4.5 4.3	0.65	6.6 6.2	1	0.75 0.45	0.65 0.45	0.2	0.13	0.1	0.48 0.18	10° 0°

Note

1. Plastic or metal protrusions of 0.20 mm maximum per side are not included.

OUTLINE VERSION	REFERENCES				EUROPEAN PROJECTION	ISSUE DATE
	IEC	JEDEC	JEITA			
SOT266-1		MO-152				99-12-27 03-02-19

1GHz low voltage LNA, mixer and VCO

SA620

REVISION HISTORY

Rev	Date	Description
_2	20041214	Product data (9397 750 14448); supersedes SA620 of 15 Dec 1993. Modifications: <ul style="list-style-type: none">• Added package outline and legal information.
_1	19931215	Product specification

1GHz low voltage LNA, mixer and VCO

SA620

Data sheet status

Level	Data sheet status ^[1]	Product status ^{[2] [3]}	Definitions
I	Objective data	Development	This data sheet contains data from the objective specification for product development. Philips Semiconductors reserves the right to change the specification in any manner without notice.
II	Preliminary data	Qualification	This data sheet contains data from the preliminary specification. Supplementary data will be published at a later date. Philips Semiconductors reserves the right to change the specification without notice, in order to improve the design and supply the best possible product.
III	Product data	Production	This data sheet contains data from the product specification. Philips Semiconductors reserves the right to make changes at any time in order to improve the design, manufacturing and supply. Relevant changes will be communicated via a Customer Product/Process Change Notification (CPCN).

[1] Please consult the most recently issued data sheet before initiating or completing a design.

[2] The product status of the device(s) described in this data sheet may have changed since this data sheet was published. The latest information is available on the Internet at URL <http://www.semiconductors.philips.com>.

[3] For data sheets describing multiple type numbers, the highest-level product status determines the data sheet status.

Definitions

Short-form specification — The data in a short-form specification is extracted from a full data sheet with the same type number and title. For detailed information see the relevant data sheet or data handbook.

Limiting values definition — Limiting values given are in accordance with the Absolute Maximum Rating System (IEC 60134). Stress above one or more of the limiting values may cause permanent damage to the device. These are stress ratings only and operation of the device at these or at any other conditions above those given in the Characteristics sections of the specification is not implied. Exposure to limiting values for extended periods may affect device reliability.

Application information — Applications that are described herein for any of these products are for illustrative purposes only. Philips Semiconductors make no representation or warranty that such applications will be suitable for the specified use without further testing or modification.

Disclaimers

Life support — These products are not designed for use in life support appliances, devices, or systems where malfunction of these products can reasonably be expected to result in personal injury. Philips Semiconductors customers using or selling these products for use in such applications do so at their own risk and agree to fully indemnify Philips Semiconductors for any damages resulting from such application.

Right to make changes — Philips Semiconductors reserves the right to make changes in the products—including circuits, standard cells, and/or software—described or contained herein in order to improve design and/or performance. When the product is in full production (status 'Production'), relevant changes will be communicated via a Customer Product/Process Change Notification (CPCN). Philips Semiconductors assumes no responsibility or liability for the use of any of these products, conveys no license or title under any patent, copyright, or mask work right to these products, and makes no representations or warranties that these products are free from patent, copyright, or mask work right infringement, unless otherwise specified.

Contact information

For additional information please visit
<http://www.semiconductors.philips.com>. Fax: +31 40 27 24825

© Koninklijke Philips Electronics N.V. 2004
 All rights reserved. Printed in U.S.A.

Date of release: 12-04

For sales offices addresses send e-mail to:
sales.addresses@www.semiconductors.philips.com

Document order number:

9397 750 14448

Let's make things better.

Looking for pricing, stock, or lifecycle information?

Click below to explore more details on WIN SOURCE:

 [View SA620DK,112 on WIN SOURCE](#)

 [NXP / Nexperia Information](#)

Optimize Your Supply Chain with WIN SOURCE Solutions

-  Global Sourcing Solution
-  Obsolete Management
-  Cost Control Management
-  Shortage Management
-  Alternative Solution
-  Excess Inventory Management