



**THE DATASHEET OF  
SKY65373-11**



**DATA SHEET**

# SKY65373-11: 1710 to 1785 MHz High Linearity, Active Bias Low-Noise Variable Gain Amplifier

**Applications**

- LTE, WCDMA, GSM wireless infrastructure
- Low noise, high linearity systems
- Macro base stations
- Small cells

**Features**

- Fully integrated low-noise front end
- High gain: 42 dB
- Excellent return loss: >20 dB
- High linearity gain control > 35 dB
- Low Noise Figure: 0.82 dB
- Switchable high/low gain state modes
- Temperature and process stable active bias
- Small MCM (16-pin, 8 x 8 mm) package (MSL3 @ 260 °C per JEDEC J-STD-020)



Skyworks Green™ products are compliant with all applicable legislation and are halogen-free. For additional information, refer to *Skyworks Definition of Green™*, document number SQ04-0074.

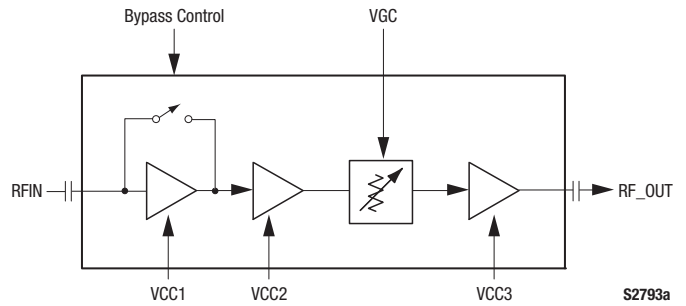

**Figure 1. SKY65373-11 Block Diagram**

**Description**

The SKY65373-11 is variable gain Low-Noise Amplifier (LNA) with an active bias and high linearity performance. The first stage of the device is comprised of an LNA with a bypass switch that is followed by a high linearity driver amplifier, a variable voltage gain attenuator, and a high linearity power amplifier. This module architecture provides excellent return loss, low noise, and high linearity performance.

The internal active bias circuitry ensures repeatable performance over temperature. The device is fully integrated and requires minimal external components.

The SKY65373-11 is manufactured in a compact, 8 x 8 mm, 16-pin Multi-Chip Module (MCM) package. A functional block diagram is shown in Figure 1. The pin configuration and package are shown in Figure 2. Signal pin assignments and functional pin descriptions are provided in Table 1.

The SKY65373-11 is part of a family of LNAs that cover the frequency range of 699 MHz to 2570 MHz:

- **SKY65369-11**, 832 to 862 MHz (Data Sheet # 201767)
- **SKY65370-11**, 814 to 849 MHz (Data Sheet # 201965)
- **SKY65371-11**, 880 to 915 MHz (Data Sheet # 201766)
- **SKY65372-11**, 699 to 748 MHz (Data Sheet # 202981)
- **SKY65373-11**, 1710 to 1785 MHz (this Data Sheet)
- **SKY65374-11**, 1850 to 1915 MHz (Data Sheet #201966)
- **SKY65375-11**, 1920 to 1980 MHz (Data Sheet # 201755)
- **SKY65376-11**, 2500 to 2570 MHz (Data Sheet # 202458)

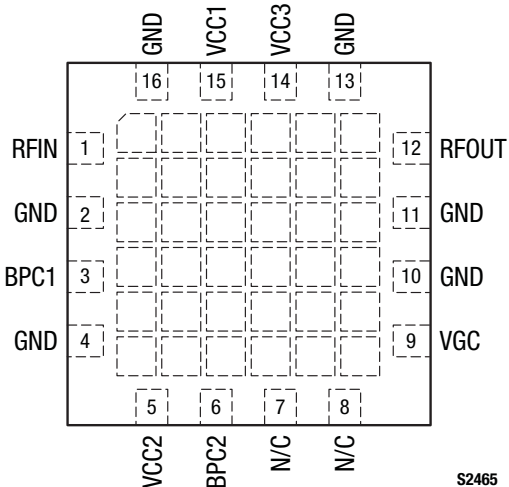

**Figure 2. SKY65373-11 Pinout - 16-Pin MCM (Top View)**

**Table 1. SKY65373-11 Signal Descriptions**

Pin	Name	Description	Pin	Name	Description
1	RFIN	RF input	9	VGC	Gain control, 0 V (maximum gain) to +3.3 V (minimum gain).
2	GND	Ground	10	GND	Ground
3	BPC1	Bypass switch for high/low gain state, terminal 1. See Table 8.	11	GND	Ground
4	GND	Ground	12	RFOUT	RF output
5	VCC2	Second state amplifier bias. Connect to +5 V, 200 mA minimum DC supply.	13	GND	Ground
6	BPC2	Bypass switch for high/low gain state, terminal 2. See Table 8.	14	VCC3	Third stage amplifier bias. Connect to +5 V, 300 mA minimum DC supply.
7	N/C	No connection. Can be left open or grounded.	15	VCC1	First stage amplifier bias. Connect to +5 V, 80 mA minimum DC supply.
8	N/C	No connection. Can be left open or grounded.	16	GND	Ground

### Electrical and Mechanical Specifications

The absolute maximum ratings of the SKY65373-11 are provided in Table 2. Electrical specifications are provided in Tables 3 through 7. The gain control logic is shown in Table 8.

**Table 2. SKY65373-11 Absolute Maximum Ratings**

Parameter	Symbol	Minimum	Maximum	Units
Supply voltage	V <sub>CC</sub>		5.5	V
RF input power	P <sub>IN</sub>		+15	dBm
Storage temperature	T <sub>STG</sub>	-55	+150	°C
Operating temperature	T <sub>A</sub>	-40	+100	°C
Junction temperature	T <sub>J</sub>		+150	°C
Thermal resistance	R <sub>TH</sub>		19	C/W

**Note:** Exposure to maximum rating conditions for extended periods may reduce device reliability. There is no damage to device with only one parameter set at the limit and all other parameters set at or below their nominal value. Exceeding any of the limits listed here may result in permanent damage to the device.

---

**CAUTION:** Although this device is designed to be as robust as possible, Electrostatic Discharge (ESD) can damage this device. This device must be protected at all times from ESD. Static charges may easily produce potentials of several kilovolts on the human body or equipment, which can discharge without detection. Industry-standard ESD precautions should be used at all times.

---

**Table 3. SKY65373-11 Recommended Operating Conditions****(@ Maximum Gain [V<sub>GC</sub> = V<sub>BPC1</sub> = 0 V, V<sub>BPC2</sub> = 3.3 V], P<sub>IN</sub> = -25 dBm, Characteristic Impedance [Z<sub>0</sub>] = 50 Ω, Unless Otherwise Noted)**

Parameter	Symbol	Minimum	Typical	Maximum	Units
RF input power	P <sub>IN</sub>		-25	-12	dBm
Frequency range	f	1710		1785	MHz
Supply voltage	V <sub>CC</sub>	4.75	5.00	5.25	V
Gain control voltage	V <sub>GC</sub>	0		+3.3	V
Bypass control voltage: Logic high	V <sub>BPC1</sub> , V <sub>BPC2</sub>	2.7	3.0	3.3	V
Logic low		0		0.6	V
Operating case temperature	T <sub>C</sub>	-40		+85	°C

**Table 4. SKY65373-11 Electrical Specifications (1 of 2) (Note 1)****(V<sub>DD</sub> = 5.0 V @ Maximum Gain [V<sub>GC</sub> = V<sub>BPC1</sub> = 0 V, V<sub>BPC2</sub> = 3.3 V], T<sub>C</sub> = +25 °C, P<sub>IN</sub> = -25 dBm, f = 1747.5 MHz, Characteristic Impedance [Z<sub>0</sub>] = 50 Ω, Unless Otherwise Noted)**

Parameter	Symbol	Test Condition	Min	Typical	Max	Units
<b>RF Specifications</b>						
Frequency range	f		1710		1785	MHz
Quiescent current	I <sub>CQ</sub>			400	445	mA
Noise Figure (Note 2)	NF	Gain = +35 dB		0.82	1.00	dB
Small signal gain	S <sub>21</sub>	P <sub>IN</sub> = -25 dBm	39	42	45	dB
Gain variation over frequency		P <sub>IN</sub> = -25 dBm: Gain = 3 and 17 dB (low gain) Gain = 18 and 35 dB (high gain)			0.8	dB
Part-to-part gain variation		Gain = 29, 27, 25, 21, 13, 10, and 7 dB	-1		+1	
Absolute gain, high gain mode	G <sub>MIN_HIGHGAIN</sub>	P <sub>IN</sub> = -25 dBm, BPC1 = 0, BPC2 = 1, V <sub>GC</sub> = 3.3 V		14	16	dB
Absolute gain, low gain mode	G <sub>MAX_LOWGAIN</sub>	P <sub>IN</sub> = -25 dBm, BPC1 = 1, BPC2 = 0, V <sub>GC</sub> = 0 V	19	20.5		dB
Absolute gain, low gain mode	G <sub>MIN_LOWGAIN</sub>	P <sub>IN</sub> = -25 dBm, BPC1 = 1, BPC2 = 0, V <sub>GC</sub> = 3.3 V		-8	1	dB
Input return loss	S <sub>11</sub>	P <sub>IN</sub> = -25 dBm: Gain = 3 dB (low gain) Gain = 17 dB (low gain) Gain = 18 dB (high gain) Gain = 35 dB (high gain)	20 20 19 21			dB dB dB dB
Output return loss	S <sub>22</sub>	P <sub>IN</sub> = -25 dBm: Gain = 3 dB (low gain) Gain = 17 dB (low gain) Gain = 18 dB (high gain) Gain = 35 dB (high gain)	15.5 15.5 15.5 15.5			dB dB dB dB
Reverse isolation	S <sub>12</sub>	P <sub>IN</sub> = -25 dBm, Gain = 35 dB (high gain)	62			dB

**Table 4. SKY65373-11 Electrical Specifications (2 of 2) (Note 1)**  
**(VDD = 5.0 V @ Maximum Gain [VGC = VBPC1 = 0 V, VBPC2 = 3.3 V], Tc = +25 °C, PIN = -25 dBm, f = 1747.5 MHz, Characteristic Impedance [Zo] = 50 Ω, Unless Otherwise Noted)**

Parameter	Symbol	Test Condition	Min	Typical	Max	Units
<i>RF Specifications (continued)</i>						
3 <sup>rd</sup> Order Input Intercept Point (Note 3)	IIP3	$\Delta f = 1 \text{ MHz}$ , PIN = -25 dBm/tone:				
		Gain = 11 dB	+18.5			dBm
		Gain = 17 dB	+15			dBm
		Gain = 29 dB	+5			dBm
		Gain = 35 dB	+5			dBm
1 dB Input Compression Point (Note 4)	IP1dB	Gain = 11 dB	+12			dBm
		Gain = 17 dB	+8			dBm
		Gain = 29 dB	-9			dBm
		Gain = 35 dB	-11			dBm

**Note 1:** Performance is guaranteed only under the conditions listed in this Table. Recommended gain switching point between high and low gain is 17.5 dB.

**Note 2:** Loss from the input SMA connector and Evaluation Board up to pin 1 has been de-embedded from the NF measurement. See Table 5 for the full specification. The Evaluation Board input and output trace loss (typical) is 0.07 dB.

**Note 3:** See Table 6 for the full specification.

**Note 4:** See Table 7 for the full specification.

**Table 5. SKY65373-11 Electrical Specifications: Noise Figure (Note 1)**  
**(VDD = 4.75 to 5.25 V, Tc = -40 to +85 °C, PIN = -25 dBm, f = 1.710 to 1.785 GHz, Characteristic Impedance [Zo] = 50 Ω, Unless Otherwise Noted)**

Parameter	Symbol	Test Condition	Min	Typical	Max	Units
Noise Figure	NF	Gain = 3 dB			23.50	dB
		Gain = 4 to 6 dB			22.80	dB
		Gain = 7 and 8 dB			20.80	dB
		Gain = 9 and 10 dB			18.80	dB
		Gain = 11 and 12 dB			16.80	dB
		Gain = 13 and 14 dB			14.80	dB
		Gain = 15 and 16 dB			12.80	dB
		Gain = 17 and 18 dB			10.80	dB
		Gain = 19 and 20 dB			8.80	dB
		Gain = 21 and 22 dB			7.30	dB
		Gain = 23 and 24 dB			5.30	dB
		Gain = 25 and 26 dB			3.50	dB
		Gain = 27 dB			2.60	dB
		Gain = 28 dB			2.40	dB
		Gain = 29 dB			2.20	dB
		Gain = 30 dB			2.10	dB
		Gain = 31 dB			1.75	dB
Gain = 32 dB			1.60	dB		
Gain = 33 dB			1.45	dB		
Gain = 34 dB			1.35	dB		
Gain = 35 dB			1.25	dB		

**Note 1:** Verified by characterization.

**Table 6. SKY65373-11 Electrical Specifications: IIP3 (Note 1)**  
**(V<sub>DD</sub> = 4.75 to 5.25 V, T<sub>c</sub> = -40 to +85 °C, P<sub>IN</sub> = -25 dBm/Tone, f = 1710 to 1785 MHz, Δf = 1 MHz, Characteristic Impedance [Z<sub>0</sub>] = 50 Ω, Unless Otherwise Noted)**

Parameter	Symbol	Test Condition	Min	Typical	Max	Units
3 <sup>rd</sup> Order Input Intercept Point	IIP3	Gain = 30 to 35 dB	+1			dBm
		Gain = 18 to 29 dB	+3			dBm
		Gain = 12 to 17 dB	+14			dBm
		Gain = 3 to 11 dB	+18			dBm

Note 1: Verified by characterization.

**Table 7. SKY65373-11 Electrical Specifications: IP1dB (Note 1)**  
**(V<sub>DD</sub> = 4.75 to 5.25 V, T<sub>c</sub> = -40 to +85 °C, P<sub>IN</sub> = -25 dBm, f = 1710 to 1785 MHz, Characteristic Impedance [Z<sub>0</sub>] = 50 Ω, Unless Otherwise Noted)**

Parameter	Symbol	Test Condition	Min	Typical	Max	Units
1 dB Input Compression Point	IP1dB	Gain = 30 to 35 dB	-14.0			dBm
		Gain = 29 dB	-10.0			dBm
		Gain = 18 to 28 dB	-7.0			dBm
		Gain = 12 to 17 dB	+4.0			dBm
		Gain = 6 to 11 dB	+8.0			dBm
		Gain = 3 to 5 dB	+10.2			dBm

Note 1: Verified by characterization.

**Table 8. Gain Control Logic**

	BPC1 (Pin 3)	BPC2 (Pin 6)
High gain	0	1
Low gain	1	0

Note: "1" = 3.0 V, "0" = 0 V.

### Evaluation Board Description

The SKY65373-11 Evaluation Board is used to test the performance of the SKY65373-11 LNA. An assembly drawing for the Evaluation Board is shown in Figure 3 and the layer detail is provided in Figure 4. The layer detail physical characteristics are noted in Figure 5.

An Evaluation Board schematic diagram is provided in Figure 6. Table 9 provides the Bill of Materials (BOM) list for Evaluation Board components.

### Package Dimensions

The PCB layout footprint for the SKY65373-11 is provided in Figure 7. The typical part marking is shown in Figure 8. Package dimensions for the 16-pin MCM are shown in Figure 9, and tape and reel dimensions are provided in Figure 10.

### Package and Handling Information

Since the device package is sensitive to moisture absorption, it is baked and vacuum packed before shipping. Instructions on the shipping container label regarding exposure to moisture after the container seal is broken must be followed. Otherwise, problems related to moisture absorption may occur when the part is subjected to high temperature during solder assembly.

The SKY65373-11 is rated to Moisture Sensitivity Level 3 (MSL3) at 260 °C. It can be used for lead or lead-free soldering. For additional information, refer to Skyworks Application Note, *PCB Design and SMT Assembly/Rework Guidelines for MCM-L Packages*, document number 101752.

Care must be taken when attaching this product, whether it is done manually or in a production solder reflow environment. Production quantities of this product are shipped in a standard tape and reel format.

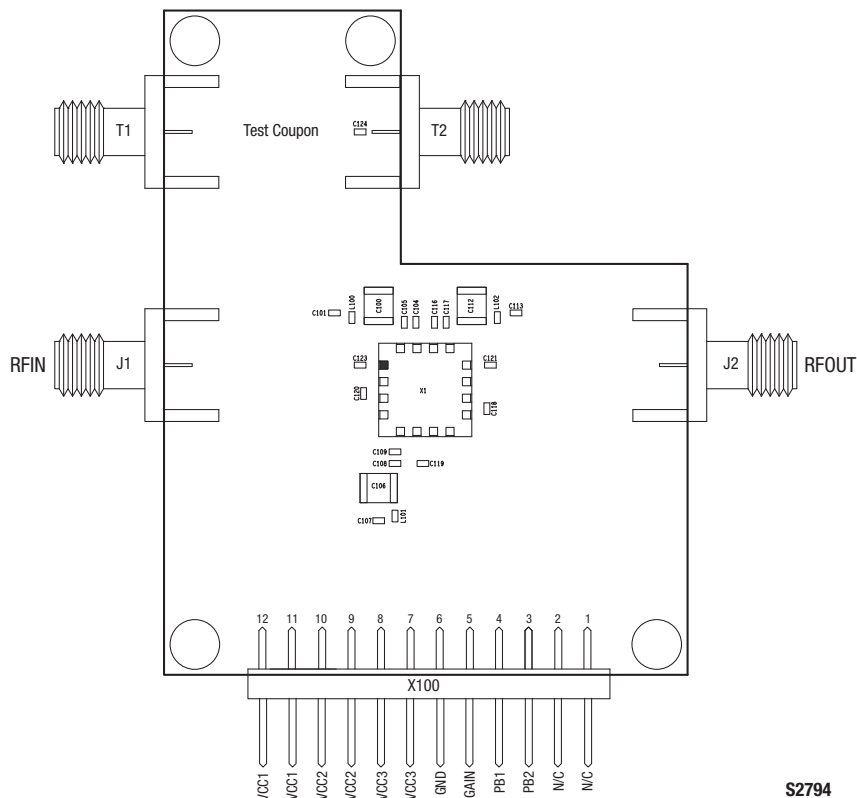
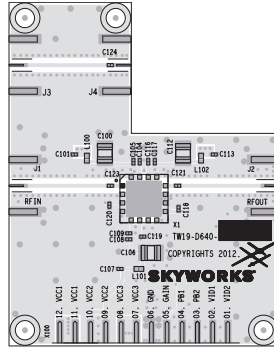
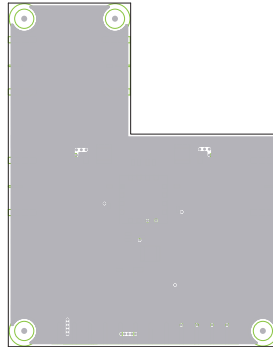

Figure 3. SKY65373-11 Evaluation Board Assembly Diagram



Layer 1: Top – Metal



Layer 2: Ground

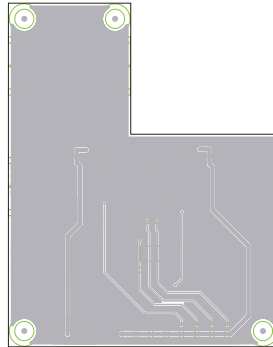

Layer 3: Signal

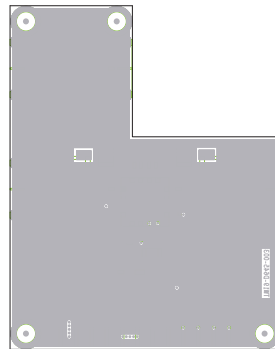

Layer 4: Bottom Ground

S2795

Figure 4. SKY65373-11 Evaluation Board Layer Detail

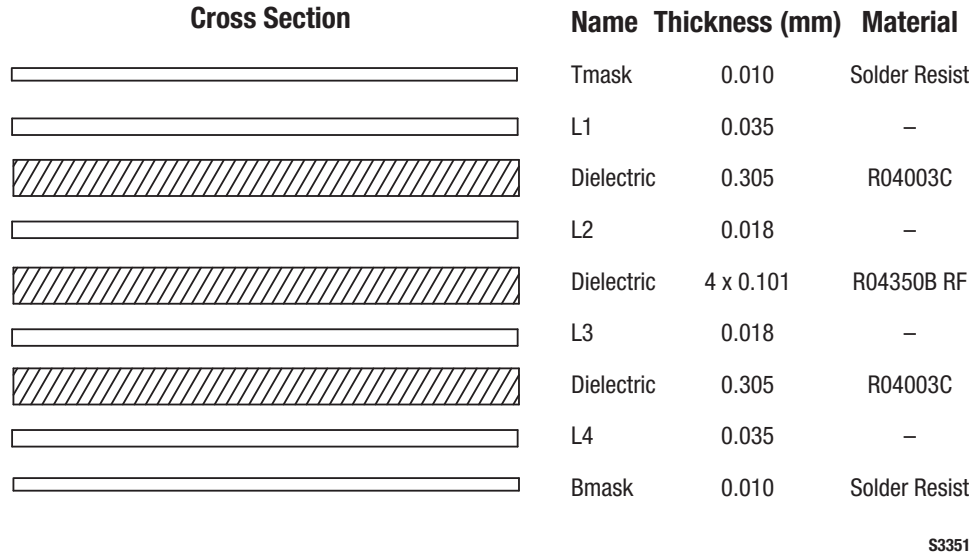

Figure 5. Layer Detail Physical Characteristics

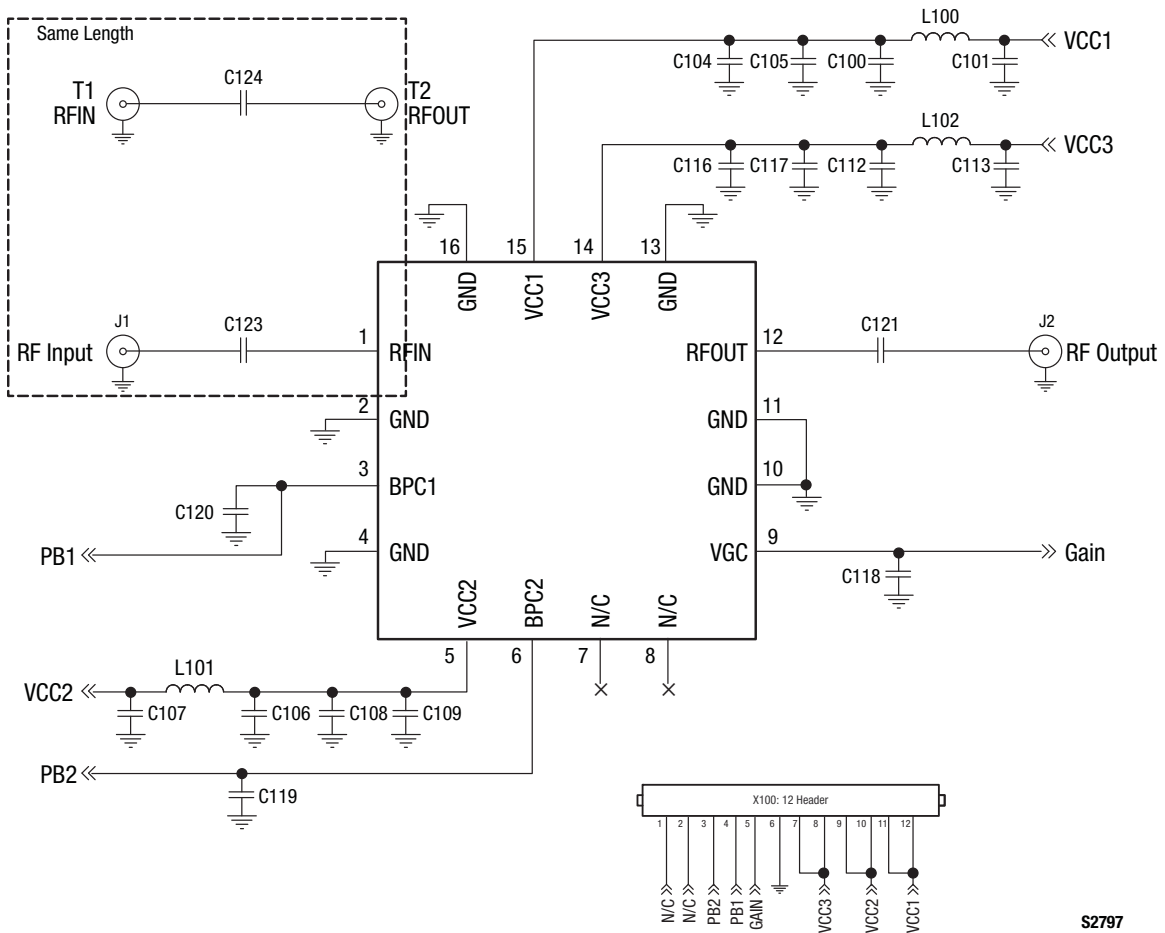
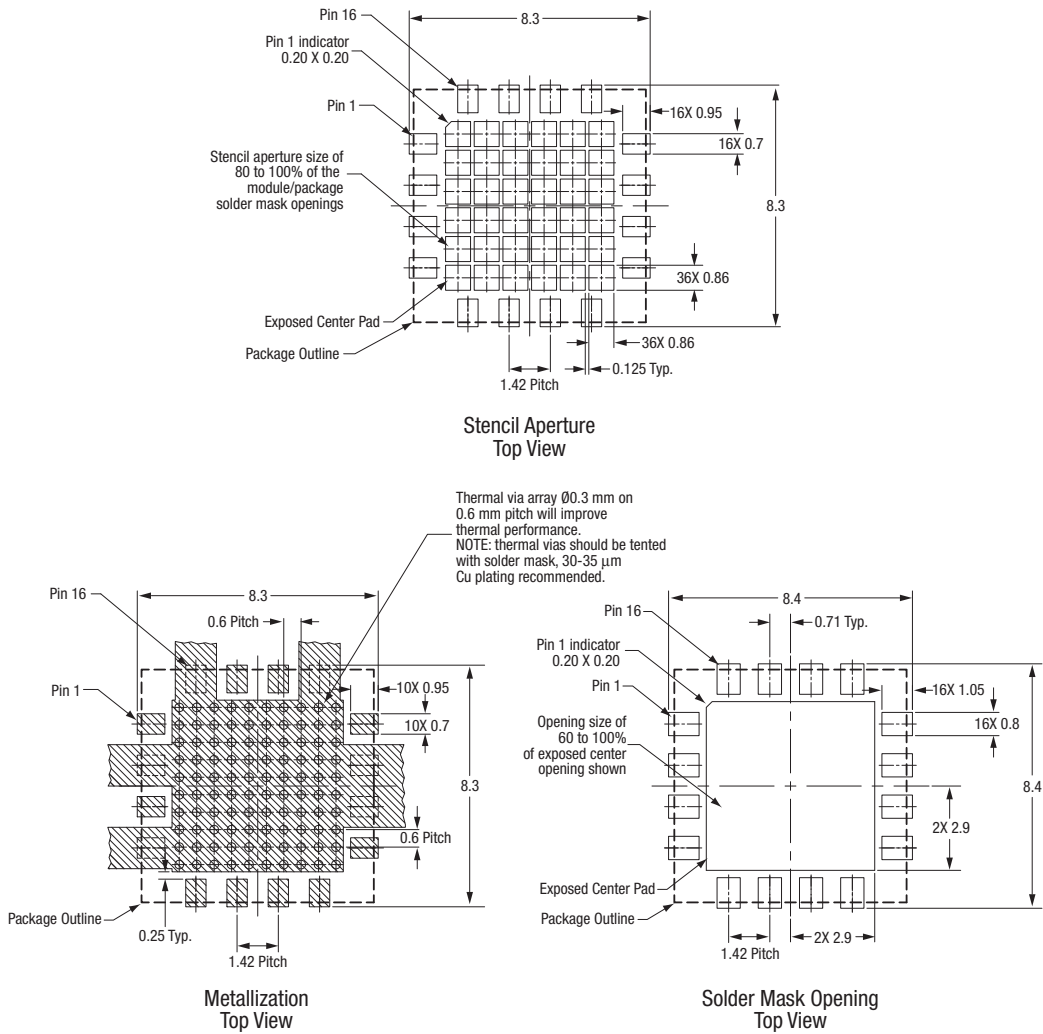

Figure 6. SKY65373-11 Evaluation Board Schematic

**Table 9. SKY65373-11 Evaluation Board Bill of Materials**

Component	Size	Value	Tolerance (%)
C100, C106, C112	1210	10 $\mu$ F	10
C101, C107, C113	0402	10 pF	5
C104, C109, C116, C119, C120, C121, C123, and C124	0402	1000 pF	5
C105, C108, C117	0402	100 nF	10
C118	0402	DNI	–
C119, C120	0402	1000 pF	5
C121, C123	0402	150 pF	5
L100, L101, L102	0603	68 nH	2



All dimensions are in millimeters

S2853

**Figure 7. SKY65373-11 PCB Layout Footprint (Top View)**

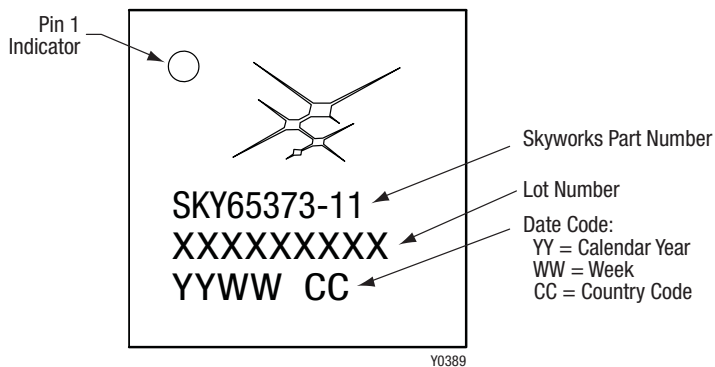

Figure 8. Typical Part Marking

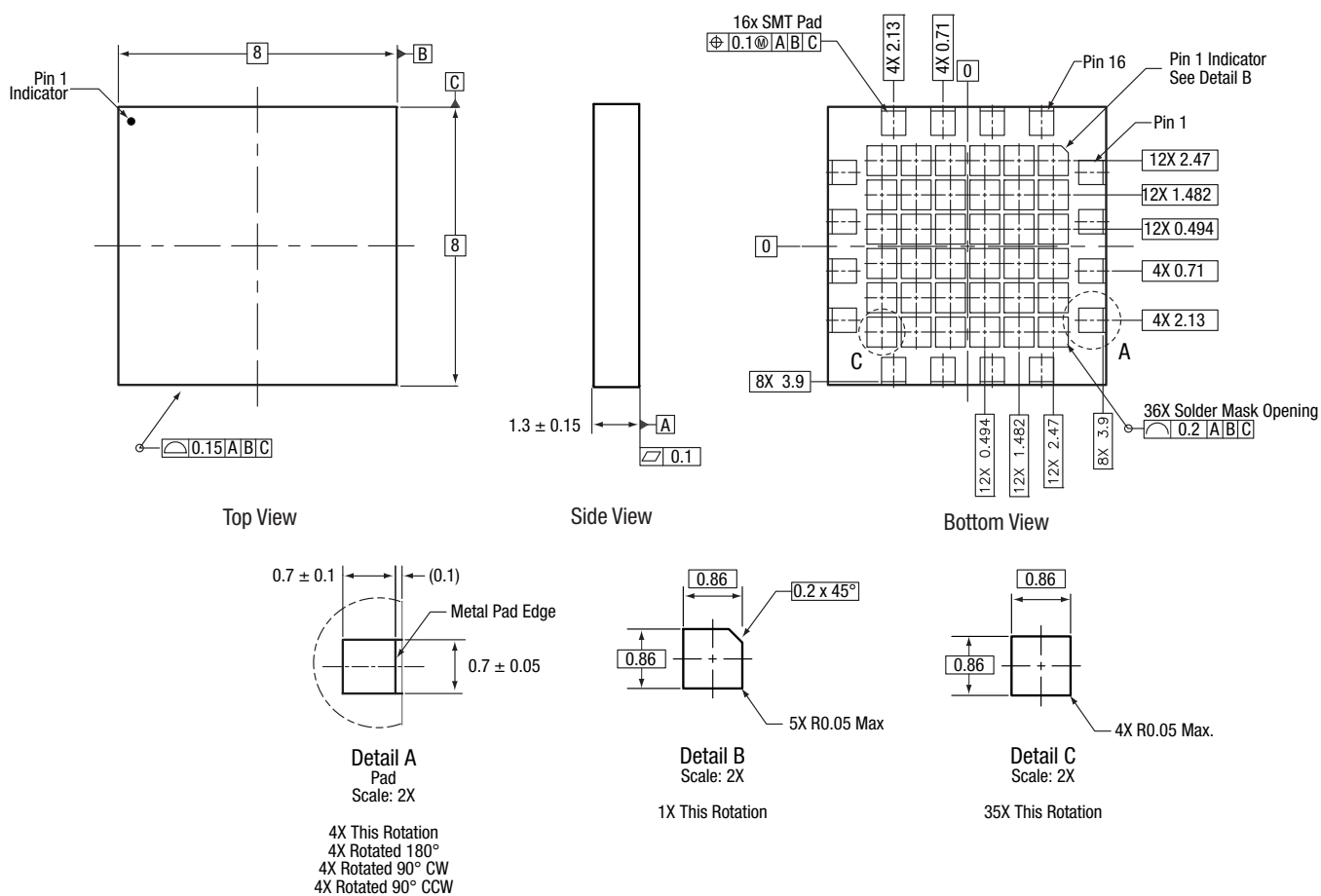
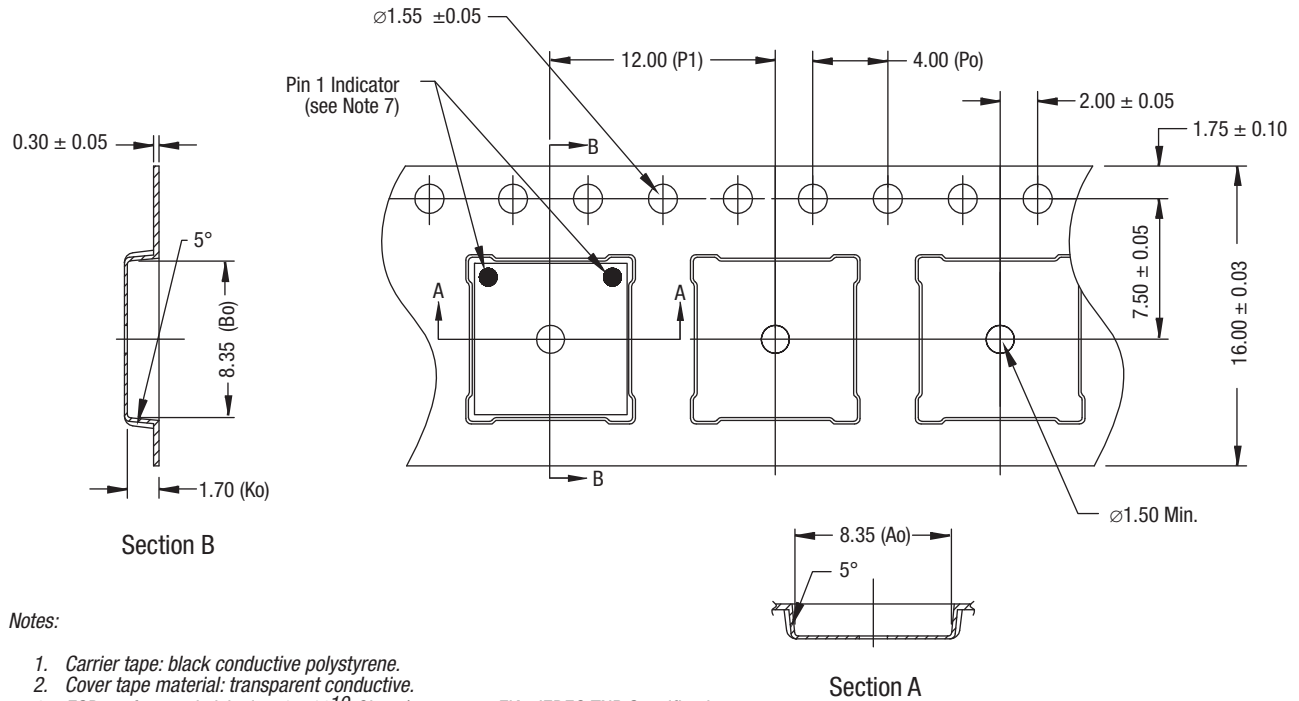

Figure 9. SKY65373-11 16-Pin MCM Package Dimensions

Dimensioning and tolerancing according to ASME Y14.5M-1994. All measurements are in millimeters

S2473



Notes:

1. Carrier tape: black conductive polystyrene.
2. Cover tape material: transparent conductive.
3. ESD-surface resistivity is  $\leq 1 \times 10^{10}$  Ohms/square per EIA, JEDEC TNR Specification.
4. Po/P1 10 pitches cumulative tolerance on tape:  $\pm 0.20$  mm.
5. Ao and Bo measurement point to be 0.30 mm from bottom pocket.
6. All dimensions are in millimeters.
7. Pin 1 orientation is in top left corner for the following Skyworks products:

SKY77503-XX	SKY65369-11	SKY65374-11
SKY77506-XX	SKY65370-11	SKY65375-11
SKY77512-XX	SKY65371-11	SKY65376-11
SKY77526-XX	SKY65372-11	SKY65379-11
SKY77343-XX	SKY65373-11	

For all other 8 x 8 mm MCM/RFLGA products, pin 1 orientation is in top right corner.

Y0491

Figure 10. SKY65373-11 Tape and Reel Dimensions

## Ordering Information

Model Name	Manufacturing Part Number	Evaluation Board Part Number
SKY65373-11 LNA	SKY65373-11	TW19-D640

Copyright © 2012-2014 Skyworks Solutions, Inc. All Rights Reserved.

Information in this document is provided in connection with Skyworks Solutions, Inc. (“Skyworks”) products or services. These materials, including the information contained herein, are provided by Skyworks as a service to its customers and may be used for informational purposes only by the customer. Skyworks assumes no responsibility for errors or omissions in these materials or the information contained herein. Skyworks may change its documentation, products, services, specifications or product descriptions at any time, without notice. Skyworks makes no commitment to update the materials or information and shall have no responsibility whatsoever for conflicts, incompatibilities, or other difficulties arising from any future changes.

No license, whether express, implied, by estoppel or otherwise, is granted to any intellectual property rights by this document. Skyworks assumes no liability for any materials, products or information provided hereunder, including the sale, distribution, reproduction or use of Skyworks products, information or materials, except as may be provided in Skyworks Terms and Conditions of Sale.

THE MATERIALS, PRODUCTS AND INFORMATION ARE PROVIDED “AS IS” WITHOUT WARRANTY OF ANY KIND, WHETHER EXPRESS, IMPLIED, STATUTORY, OR OTHERWISE, INCLUDING FITNESS FOR A PARTICULAR PURPOSE OR USE, MERCHANTABILITY, PERFORMANCE, QUALITY OR NON-INFRINGEMENT OF ANY INTELLECTUAL PROPERTY RIGHT; ALL SUCH WARRANTIES ARE HEREBY EXPRESSLY DISCLAIMED. SKYWORKS DOES NOT WARRANT THE ACCURACY OR COMPLETENESS OF THE INFORMATION, TEXT, GRAPHICS OR OTHER ITEMS CONTAINED WITHIN THESE MATERIALS. SKYWORKS SHALL NOT BE LIABLE FOR ANY DAMAGES, INCLUDING BUT NOT LIMITED TO ANY SPECIAL, INDIRECT, INCIDENTAL, STATUTORY, OR CONSEQUENTIAL DAMAGES, INCLUDING WITHOUT LIMITATION, LOST REVENUES OR LOST PROFITS THAT MAY RESULT FROM THE USE OF THE MATERIALS OR INFORMATION, WHETHER OR NOT THE RECIPIENT OF MATERIALS HAS BEEN ADVISED OF THE POSSIBILITY OF SUCH DAMAGE.



Skyworks products are not intended for use in medical, lifesaving or life-sustaining applications, or other equipment in which the failure of the Skyworks products could lead to personal injury, death, physical or environmental damage. Skyworks customers using or selling Skyworks products for use in such applications do so at their own risk and agree to fully indemnify Skyworks for any damages resulting from such improper use or sale.

Customers are responsible for their products and applications using Skyworks products, which may deviate from published specifications as a result of design defects, errors, or operation of products outside of published parameters or design specifications. Customers should include design and operating safeguards to minimize these and other risks. Skyworks assumes no liability for applications assistance, customer product design, or damage to any equipment resulting from the use of Skyworks products outside of stated published specifications or parameters.

Skyworks, the Skyworks symbol, and “Breakthrough Simplicity” are trademarks or registered trademarks of Skyworks Solutions, Inc., in the United States and other countries. Third-party brands and names are for identification purposes only, and are the property of their respective owners. Additional information, including relevant terms and conditions, posted at [www.skyworksinc.com](http://www.skyworksinc.com), are incorporated by reference.

## Looking for pricing, stock, or lifecycle information?

Click below to explore more details on WIN SOURCE:

-  [View SKY65373-11 on WIN SOURCE](#)
-  [Skyworks Solutions Inc. Information](#)

## Optimize Your Supply Chain with WIN SOURCE Solutions

-  Global Sourcing Solution
-  Obsolete Management
-  Cost Control Management
-  Shortage Management
-  Alternative Solution
-  Excess Inventory Management