



**THE DATASHEET OF
SGGP.25.4.A.02**





TAOGLAS®



Datasheet

Part No:
SGGP.25.4.A.02

Description
GPS/GLONASS/GALILEO SMD Patch Antenna

Features:
Dimensions: 25mm*25mm*4mm
Single Feed SMD Mount
GPS/GALILEO: 1575MHz
GLONASS: 1602MHz
RoHS & REACH Compliant

| | | |
|-----------|----------------------------------|-----------|
| 1. | Introduction | 2 |
| 2. | Specification | 3 |
| 3. | Antenna Characteristics | 5 |
| 4. | Radiation Patterns | 11 |
| 5. | Mechanical Drawing | 14 |
| 6. | Packaging | 15 |
| 7. | Antenna Integration Guide | 17 |
| 8. | Solder Reflow Profile | 25 |
| <hr/> | | |
| | Changelog | 26 |

Taoglas makes no warranties based on the accuracy or completeness of the contents of this document and reserves the right to make changes to specifications and product descriptions at any time without notice. Taoglas reserves all rights to this document and the information contained herein. Reproduction, use or disclosure to third parties without express permission is strictly prohibited.



1. Introduction



The Taoglas SGGP.25 is a ceramic GPS/GLONASS/Galileo passive patch antenna designed for optimal performance on GPS L1/Galileo E1 band (1575.42 MHz) and GLONASS L1 band (1602 MHz). With a low-profile thickness of just 4mm and convenient mounting via standard SMD process, it is ideal for high-volume, low-cost assembly applications.

SGGP.18 is designed for applications in navigation devices, vehicle tracking/fleet management systems, and telematics devices. It is an excellent choice for applications in transportation, defense, marine, agriculture, and navigation industries.

The SGGP.25 is manufactured and tested in an IATF16949 first tier automotive approved facility. For further optimization to customer-specific device environments, custom tuned patch antennas can be supplied, subject to NRE and MOQ.

For further information or support with integrating this antenna into your device, please contact your regional Taoglas customer support team.

2. Specification

| GNSS Frequency Bands | | | | | |
|----------------------|-------------------------|---------------------------|--------------------|--------------------|-------------------|
| GPS | L1 1575.42 MHz | L2 1227.6 MHz | L5 1176.45 MHz | | |
| | ■ | □ | □ | | |
| GLONASS | G1 1602 MHz | G2 1248 MHz | G3 1207 MHz | | |
| | ■ | □ | □ | | |
| Galileo | E1 1575.42 MHz | E5a 1176.45 MHz | E5b 1201.5 MHz | E6 1278.75 MHz | |
| | ■ | □ | □ | □ | |
| BeiDou | B1C 1575.42 MHz | B1I 1561 MHz | B2a 1176.45 MHz | B2b 1207.14 MHz | B3 1268.52 MHz |
| | ■ | ■ | □ | □ | □ |
| L-Band | L-Band 1542 MHz | | | | |
| | □ | | | | |
| QZSS (Regional) | L1 1575.42 MHz | L2C 1227.6 MHz | L5 1176.45 MHz | L6 1278.75e6 | |
| | ■ | □ | □ | □ | |
| IRNSS (Regional) | L5 1176.45 MHz | | | | |
| | □ | | | | |
| SBAS | L1/E1/B1 1575.42 MHz | L5/B2a/E5a 1176.45 MHz | G1 1602 MHz | G2 1248 MHz | G3 1207 MHz |
| | ■ | □ | ■ | □ | □ |

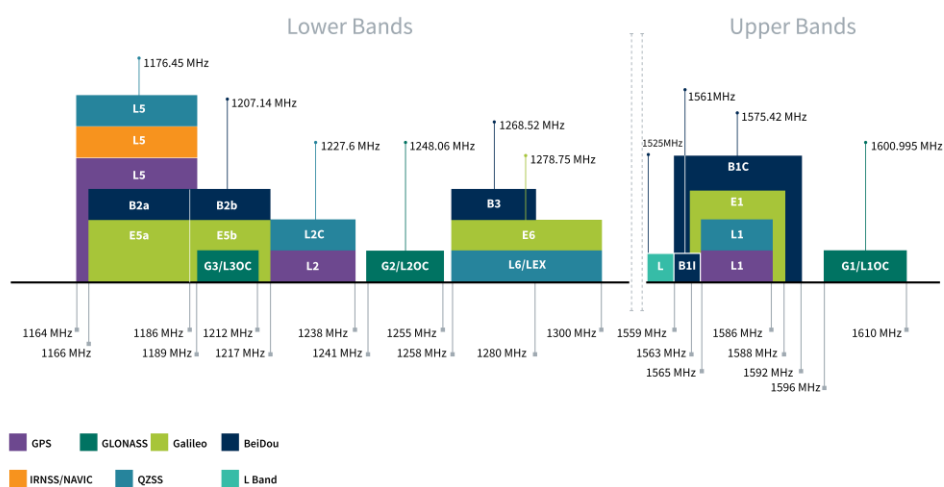

GNSS Bands and Constellations

| GNSS Electrical | | | |
|---------------------------------------|-------|---------|-------|
| Frequency (MHz) | 1561 | 1575.42 | 1603 |
| VSWR (max.) | 3:1 | 3:1 | 5:1 |
| Passive Antenna Efficiency (%) | 78.49 | 78.41 | 73.49 |
| Passive Antenna Gain at Zenith (dBic) | 3.66 | 3.66 | 3.04 |
| Polarization | RHCP | | |
| Impedance | 50 Ω | | |

| Mechanical | |
|------------|-----------|
| Dimensions | 25*25*4mm |
| Weight | 7g |
| Material | Ceramic |

| Environmental | |
|----------------------------------|----------------|
| Operating Temperature | -40°C to +85°C |
| Storage Temperature | -40°C to +85°C |
| Moisture Sensitivity Level (MSL) | 3 (168 Hours) |

3. Antenna Characteristics

3.1 Test Setup

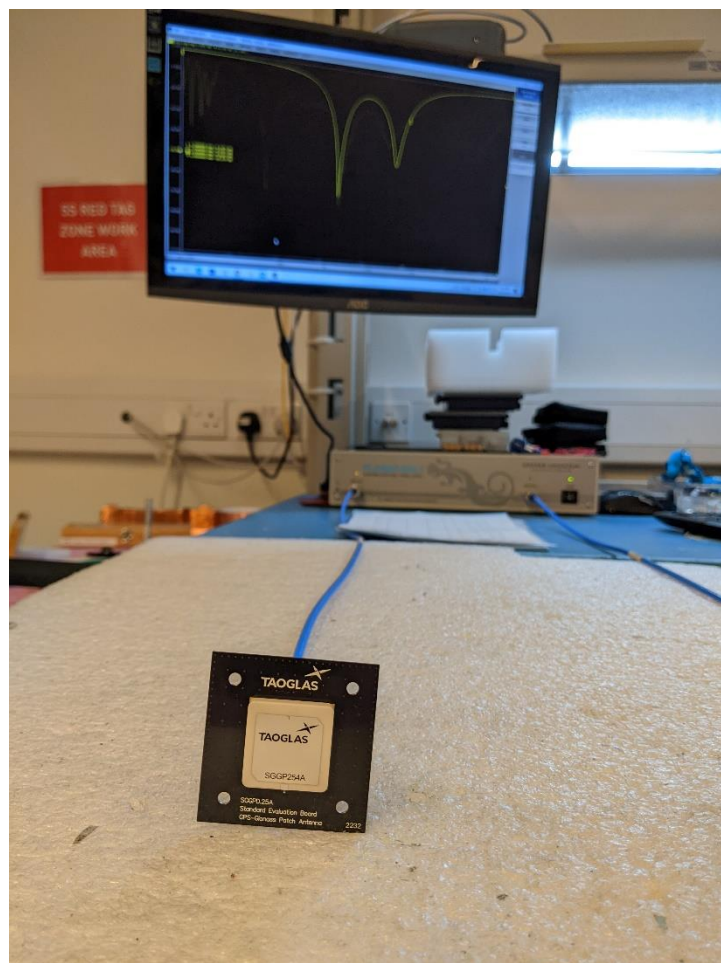
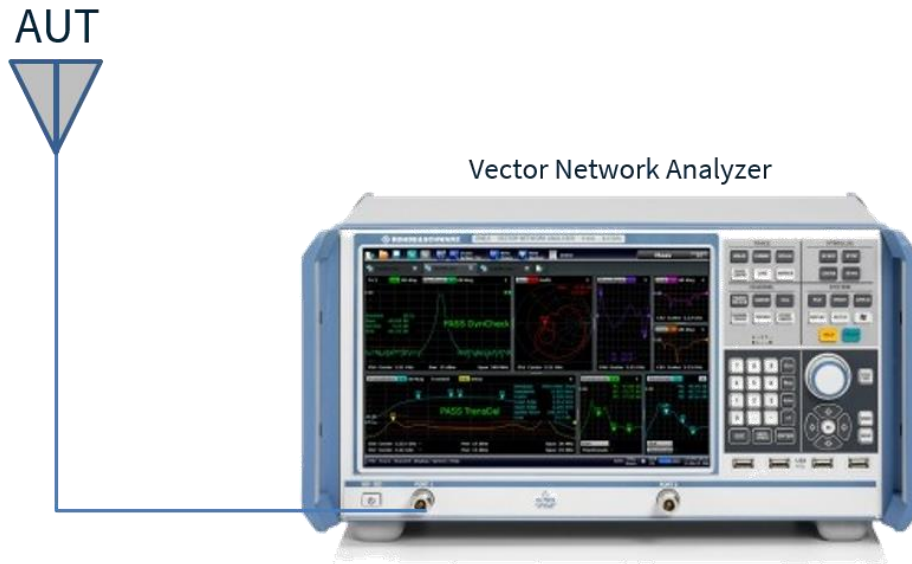

3.2 Return Loss

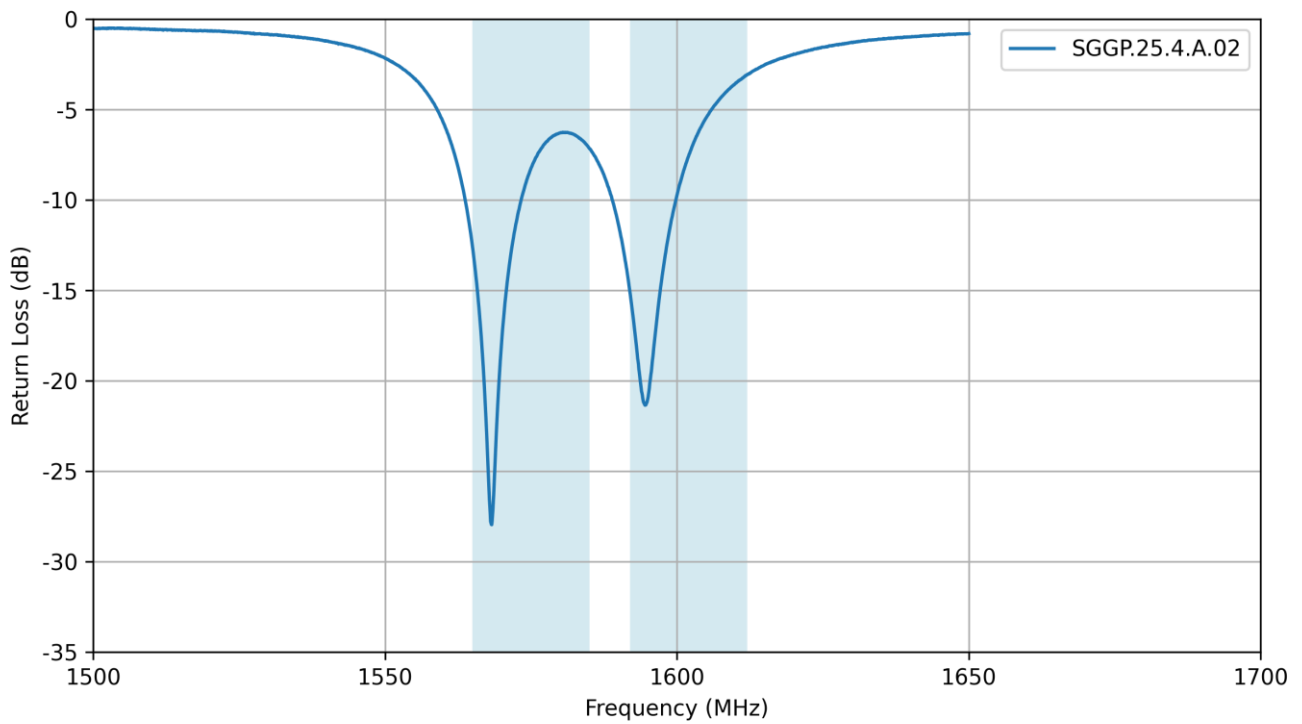

3.3 VSWR

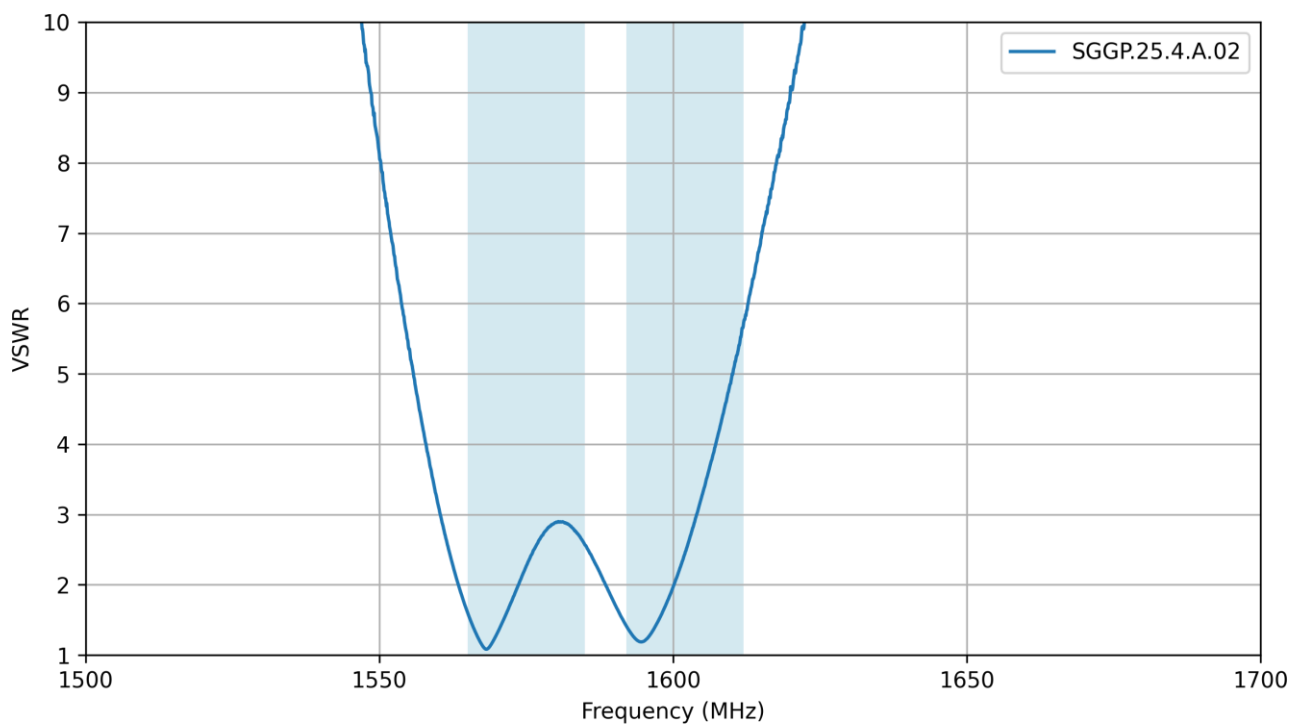

3.4 Efficiency

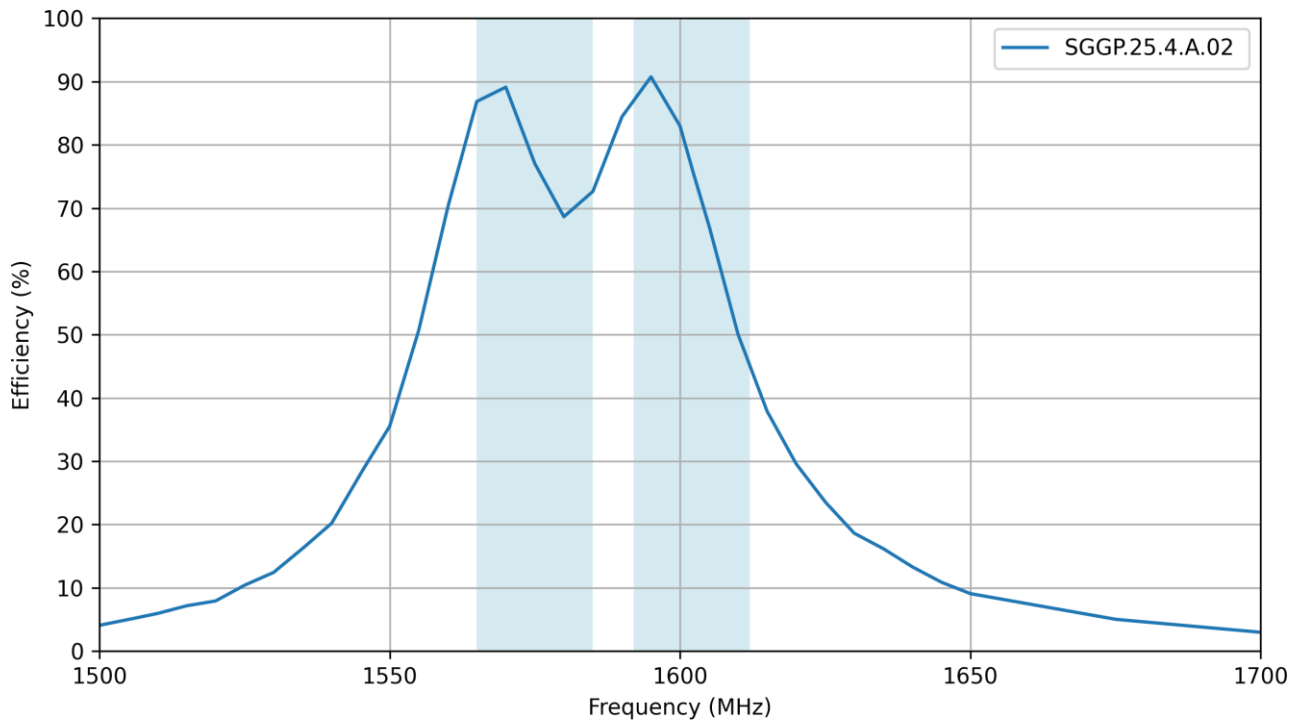

3.5 Average Gain

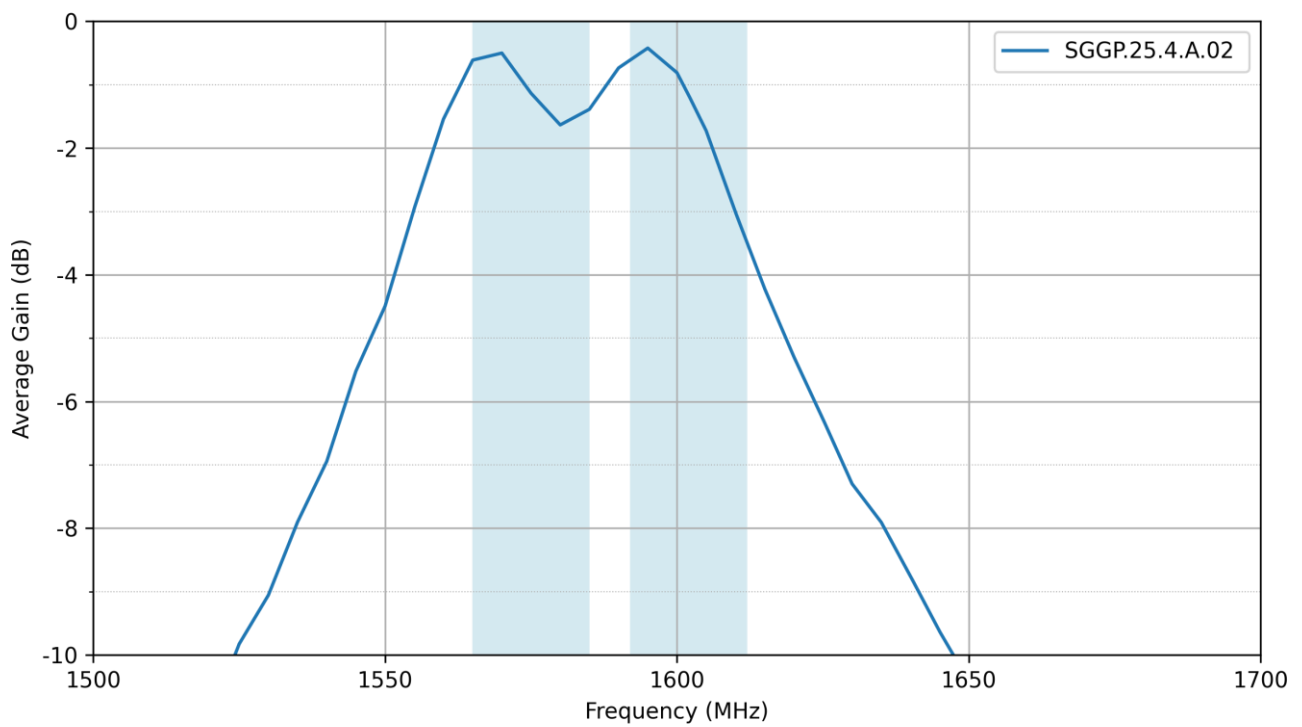

3.6 Peak Gain

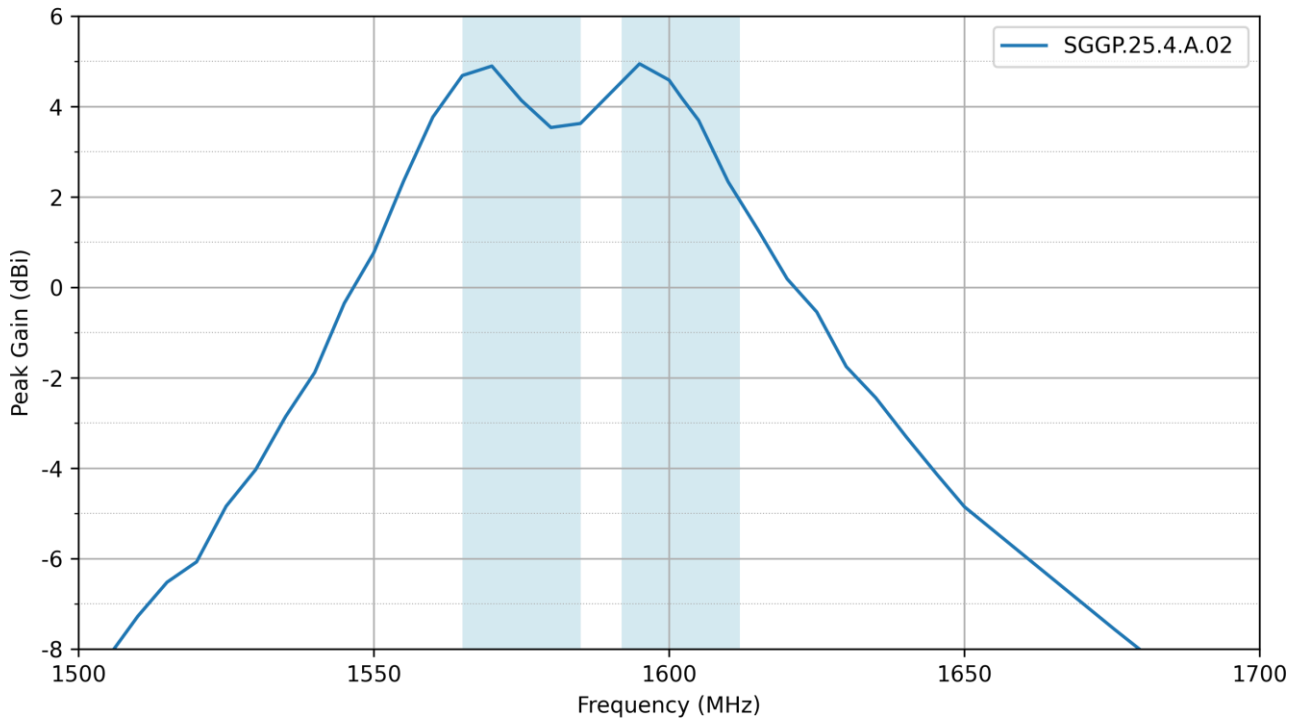

3.7 Axial Ratio

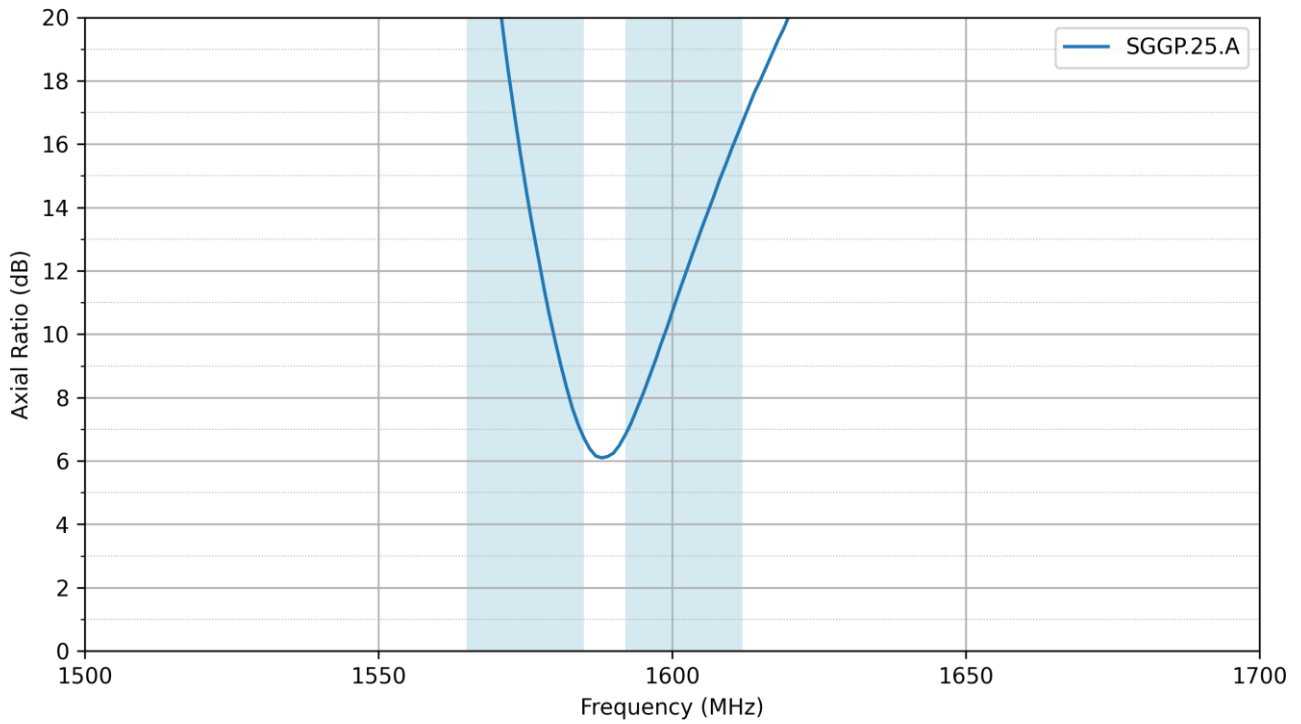

3.8 Axial Ratio vs Angle for Phi=0

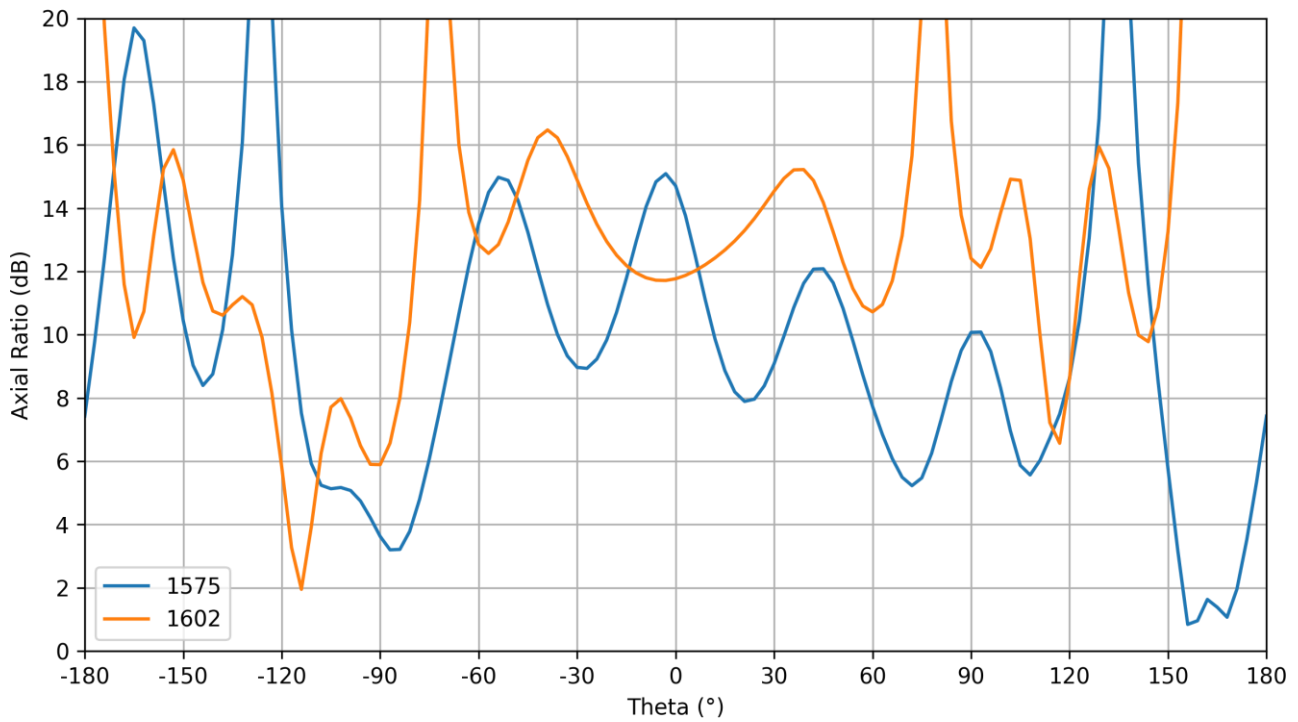

3.9 Axial Ratio vs Angle for Phi=90

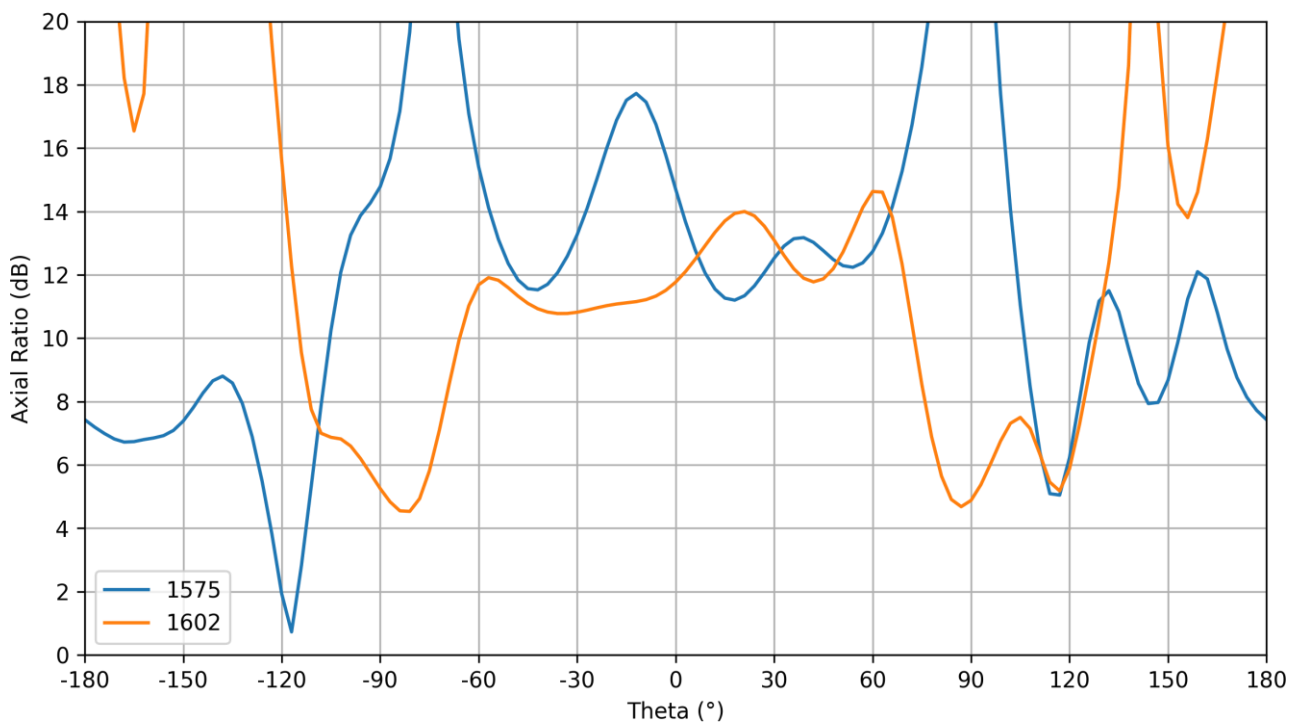

3.10 PCO

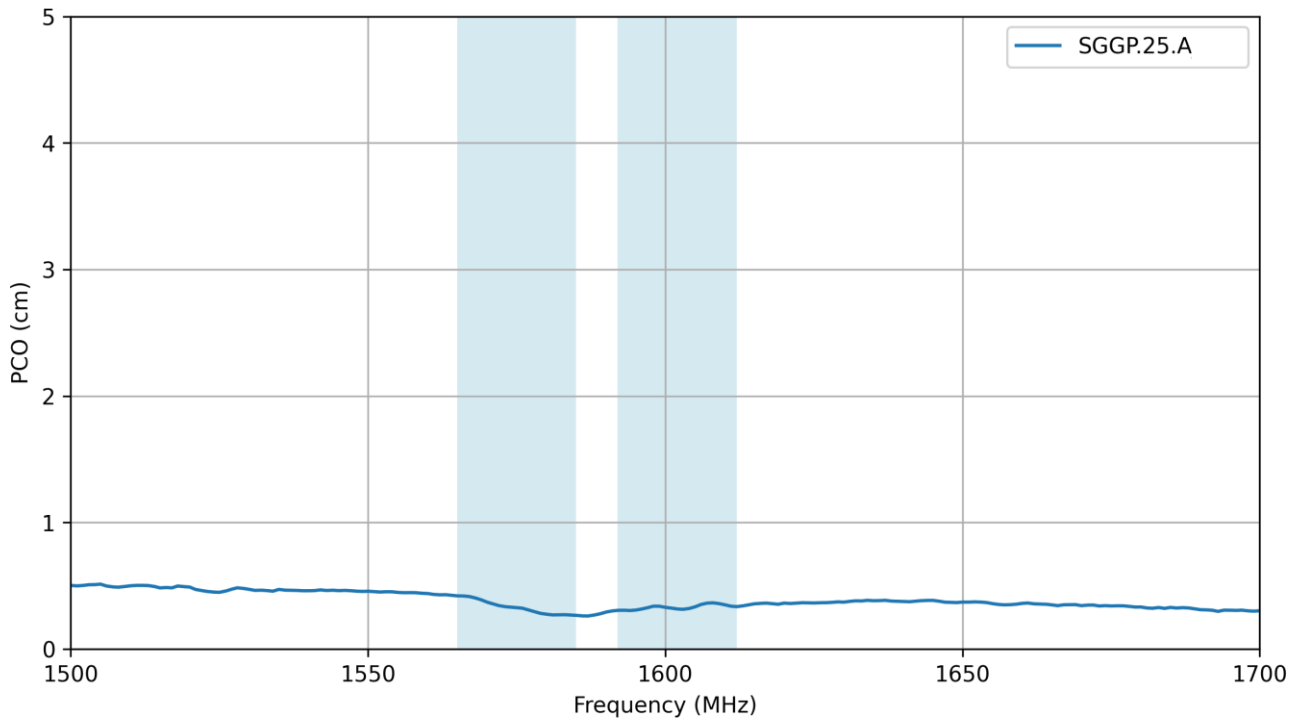

3.11 PCV

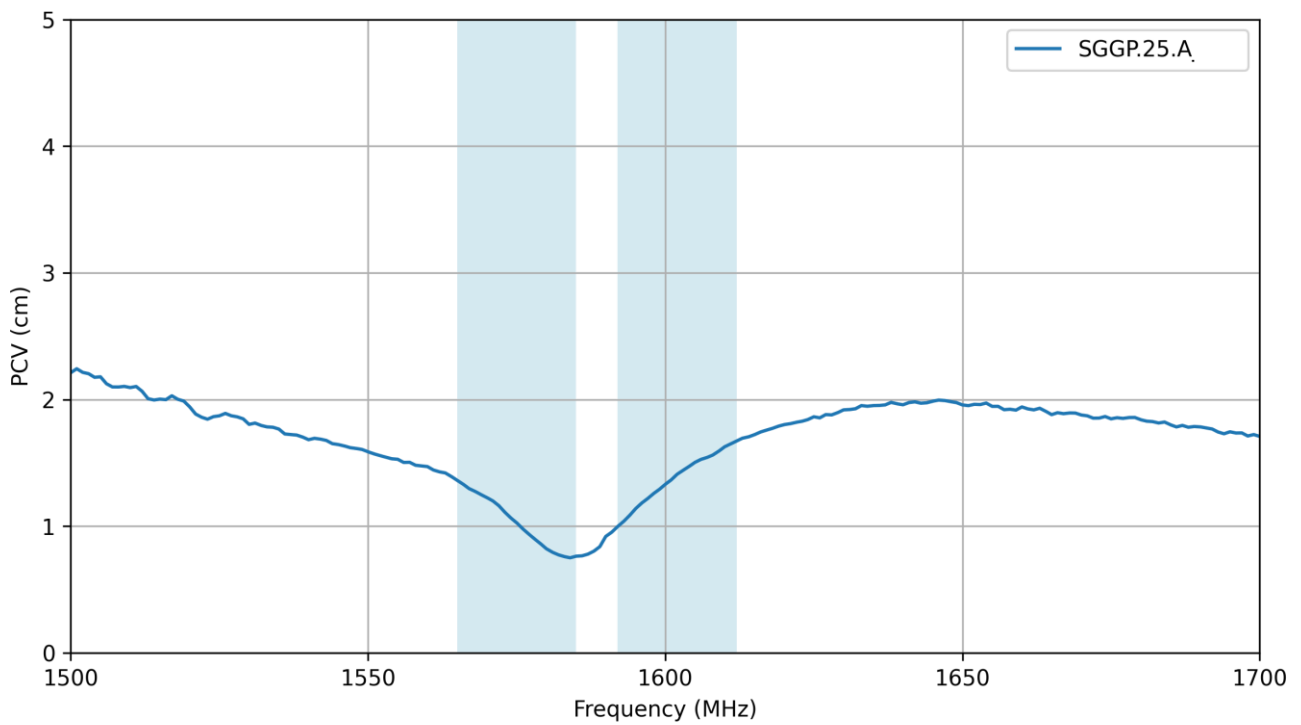

4. Radiation Patterns

4.1 Test Setup

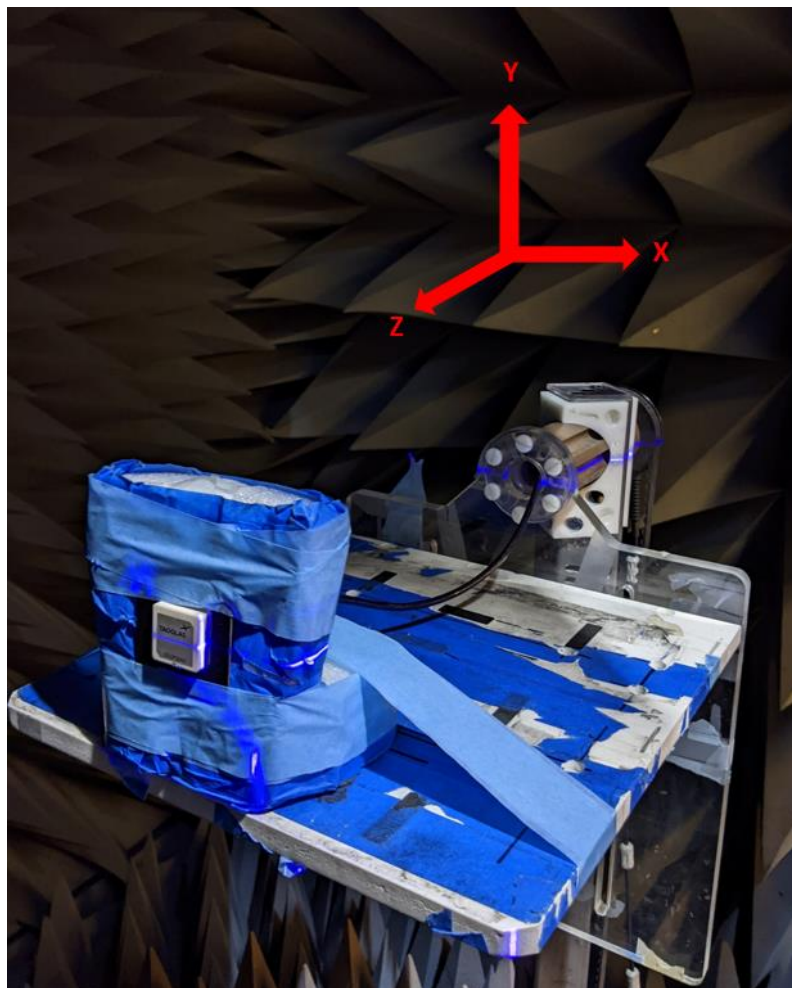
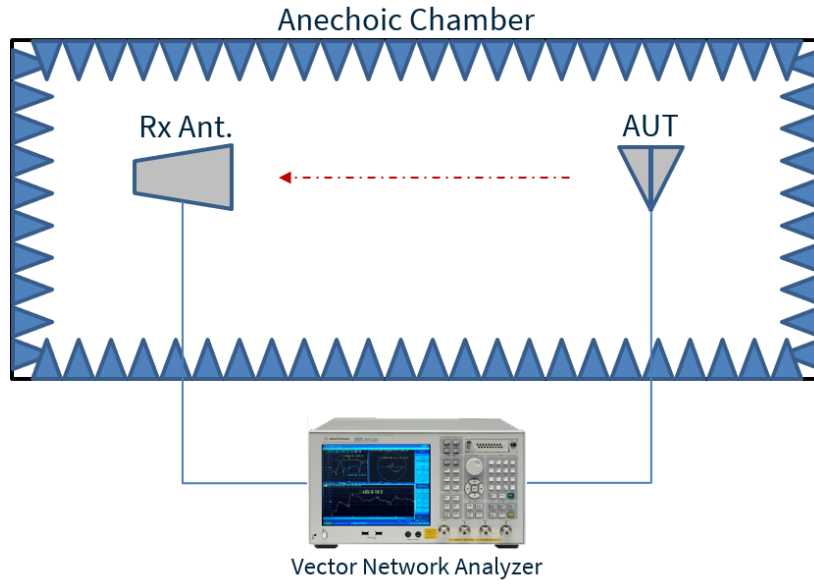

4.2 SGGP.25.4.A.02 - Patterns at 1575 MHz

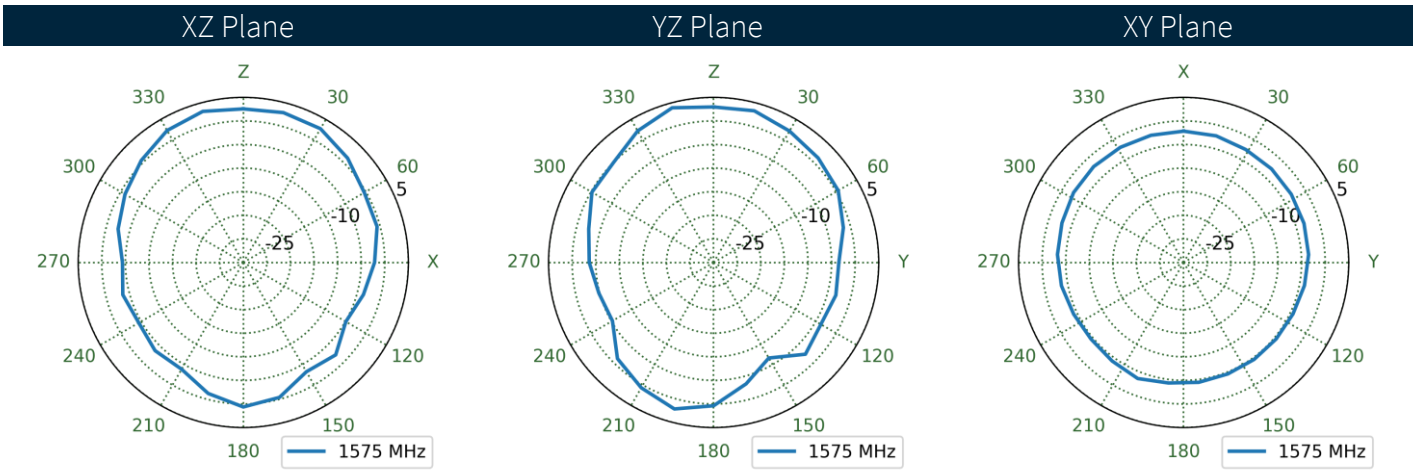
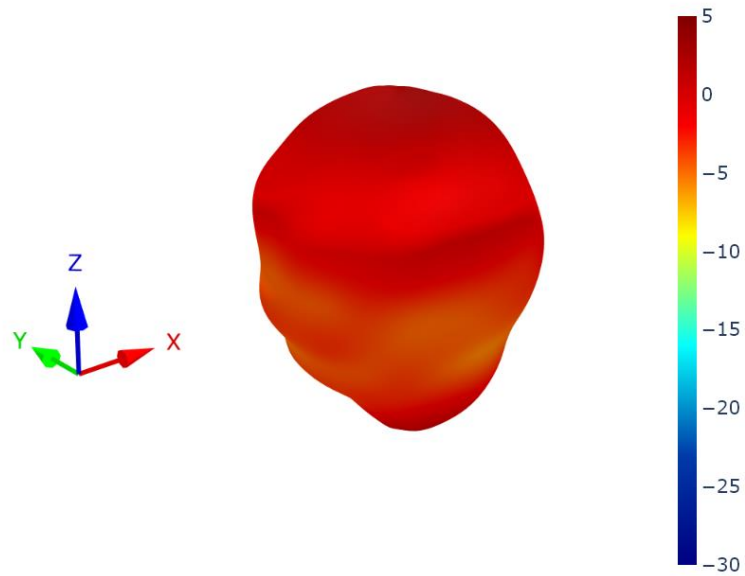

4.3 SGGP.25.4.A.02 - Patterns at 1602 MHz

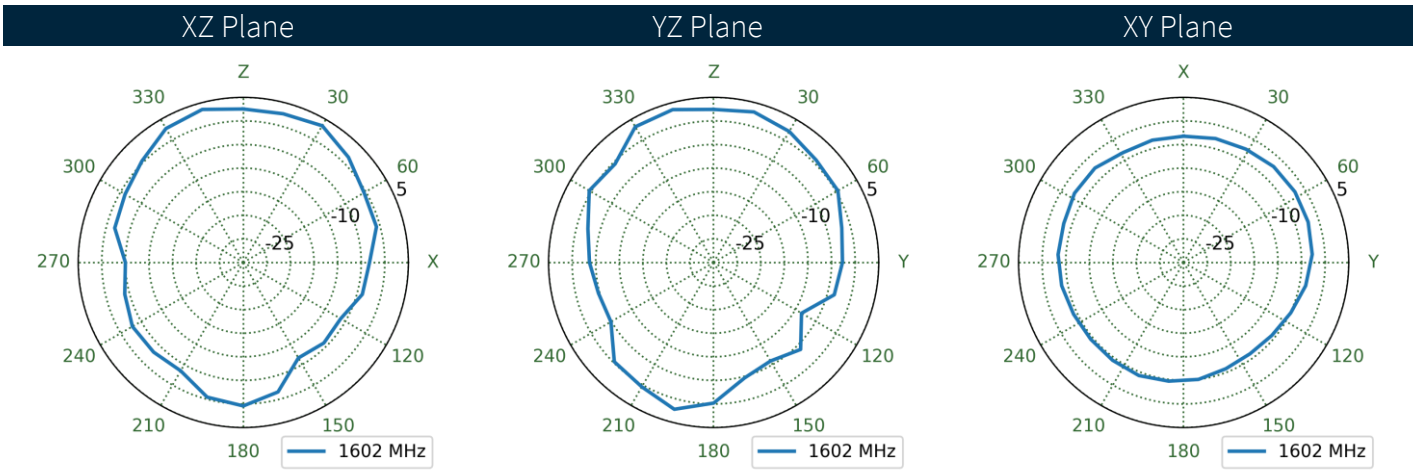
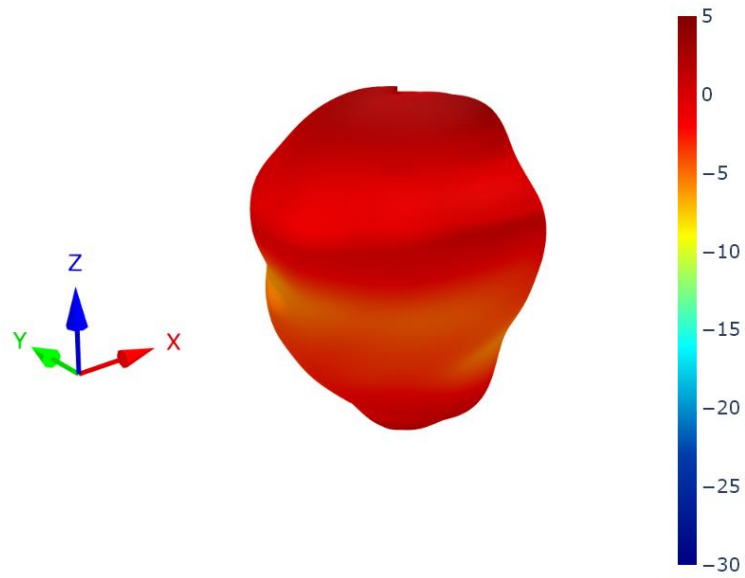

5. Mechanical Drawing

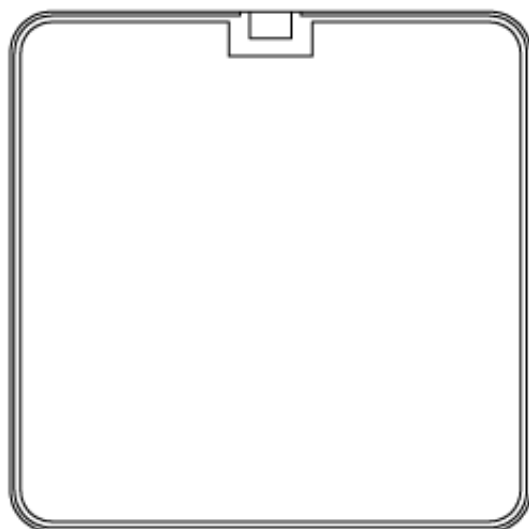
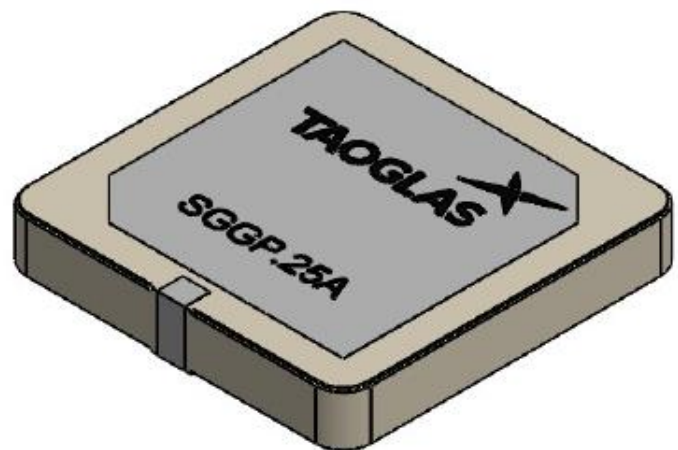
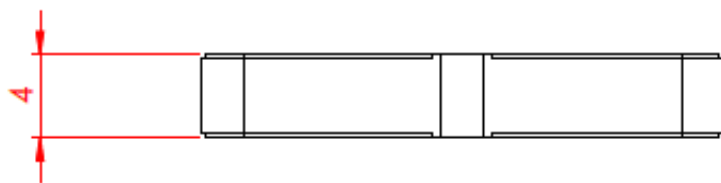
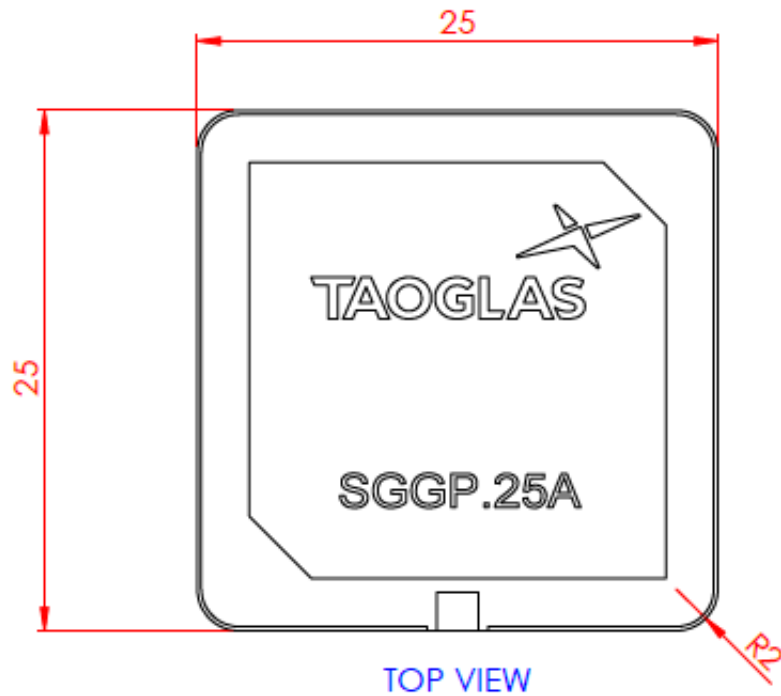

6. Packaging

200 pc SGGP.25.4.A.02 per reel

Dimensions – $\varnothing 330 \times 55 \text{mm}$

Weight – 2330g

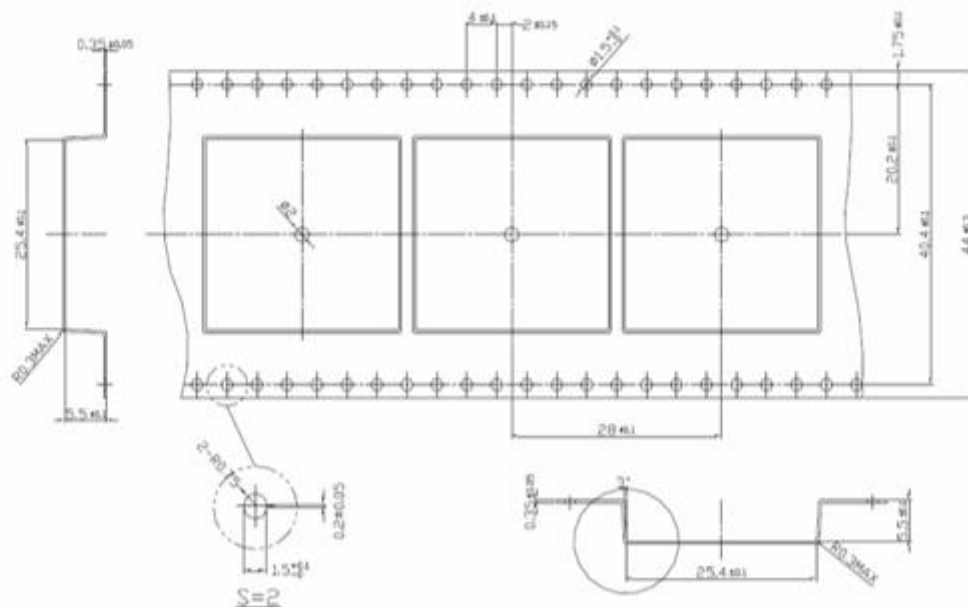
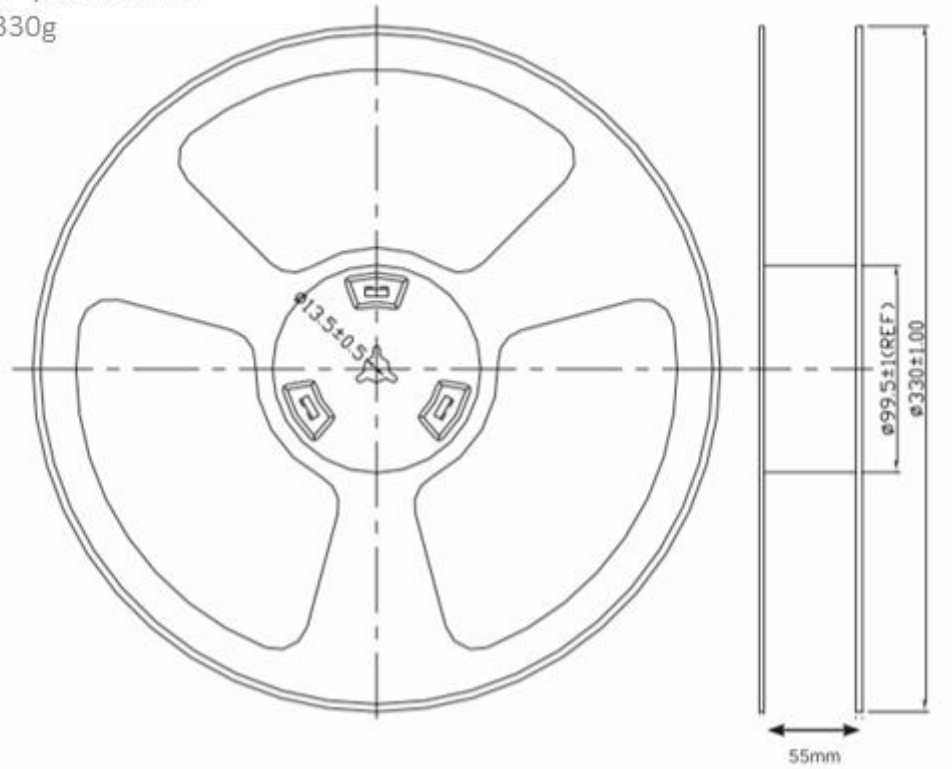

1 pc reel in small anti-static bag
 Dimensions – 340*350*70mm
 Weight – 2.63Kg

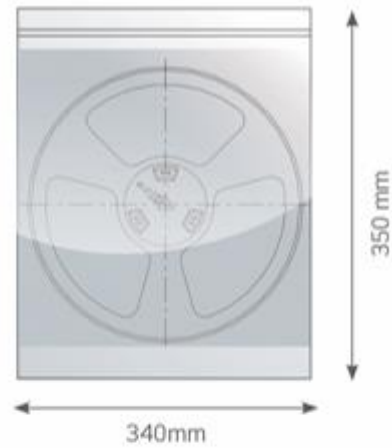

4 reels / 800 pcs in one carton
 Carton Dimensions – 370*360*305mm
 Weight – 11.3Kg

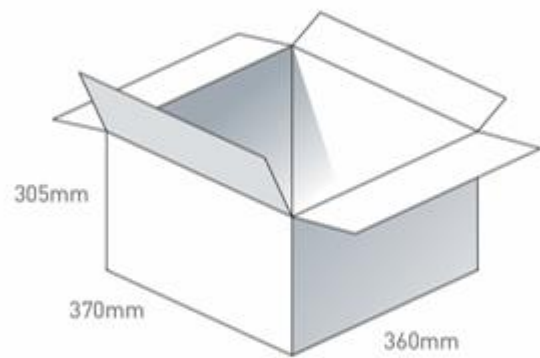

Pallet Dimensions – 1200*1000*1420mm
 24 Cartons per pallet
 6 Cartons per layer
 4 Layers

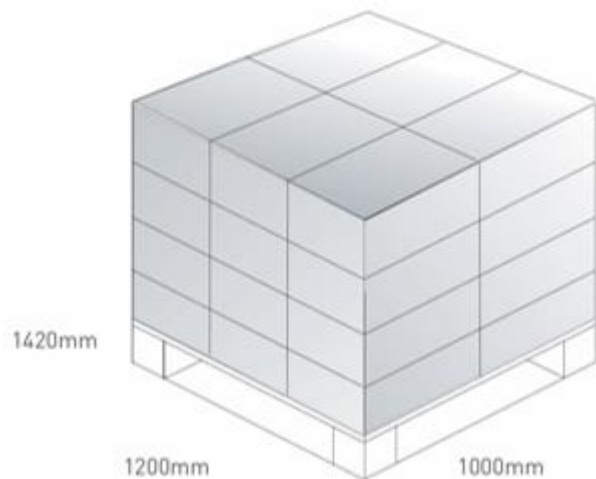

7. Antenna Integration Guide



7.1 Schematic and Symbol Definition

The circuit symbol for the antenna is shown below. The antenna has 9 pins as indicated below.

| Pin | Description |
|-----|-------------|
| 1 | RF Feed |
| 2-9 | Ground |

TAOGLAS_SGGP.25.4.A.02 ANT1

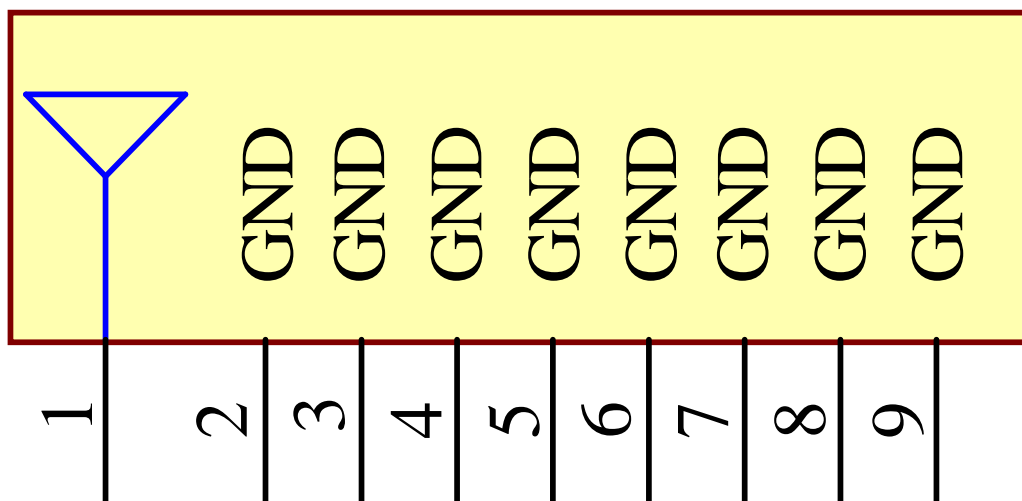

7.2 Antenna Integration

The antenna should be placed at the center of the ground plane with a length and width of 50mm. Maintaining a square symmetric ground plane shape and symmetric environment around the antenna is critical to maintaining the excellent axial ratio and phase center performance shown in this datasheet.

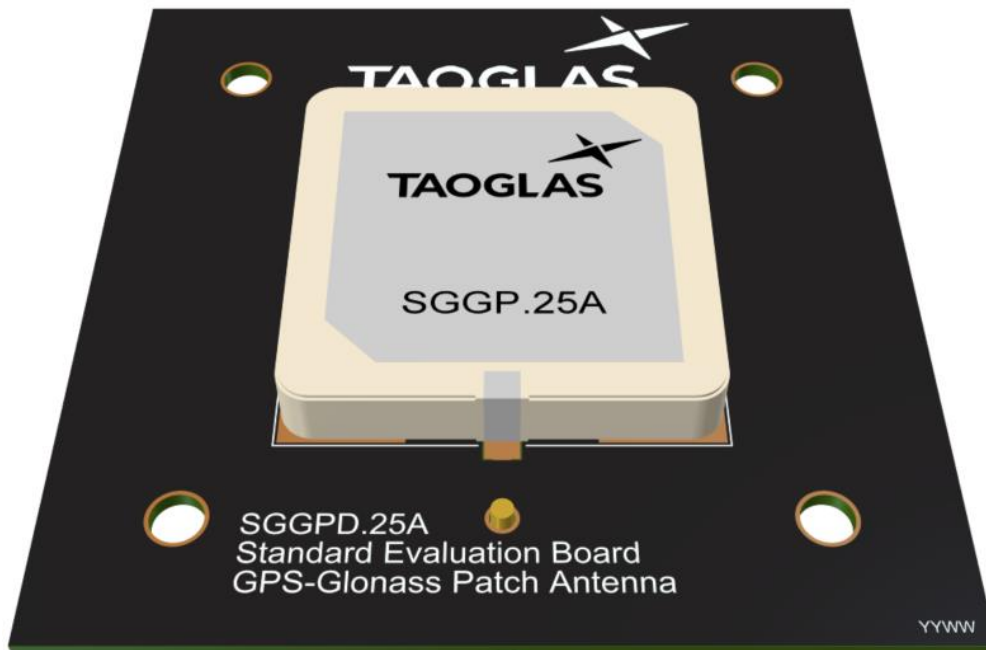

Top Side W/Solder Mask

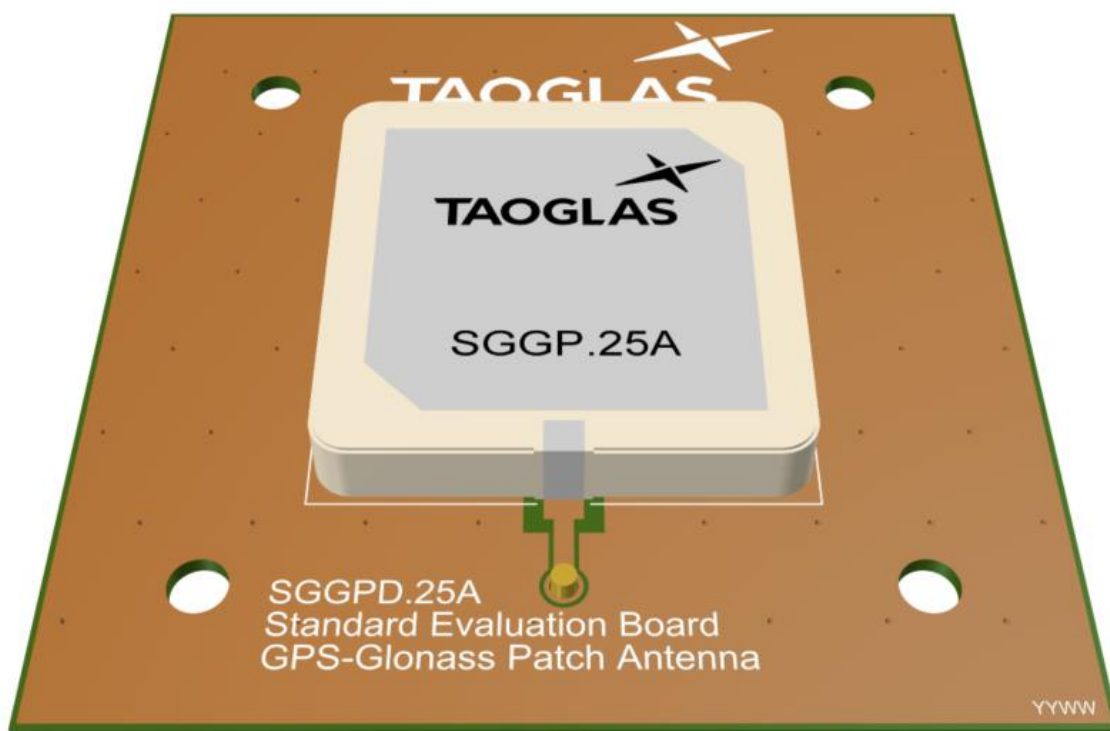

Top Side W/O Solder Mask

7.3 PCB Layout

The clearance on the PCB must comply with the antenna specification. The PCB layout shown in the diagram below demonstrates the antenna clearance.

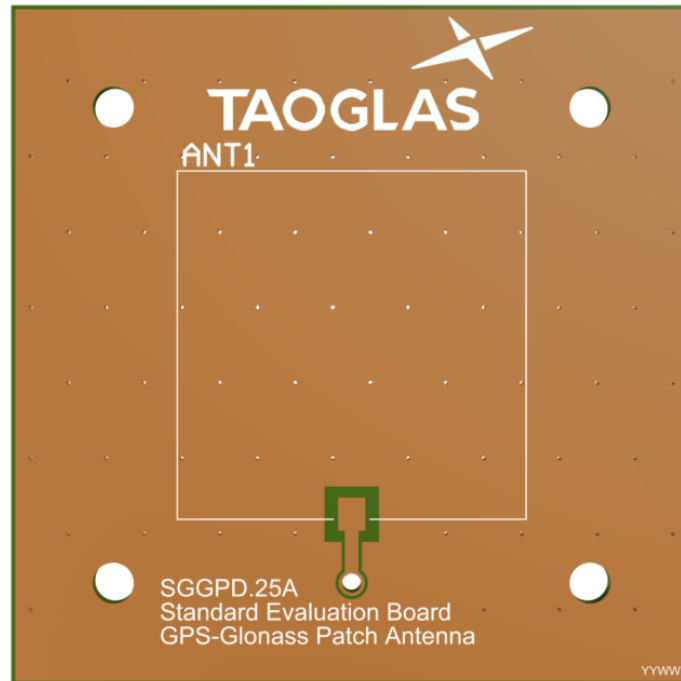

Top Side

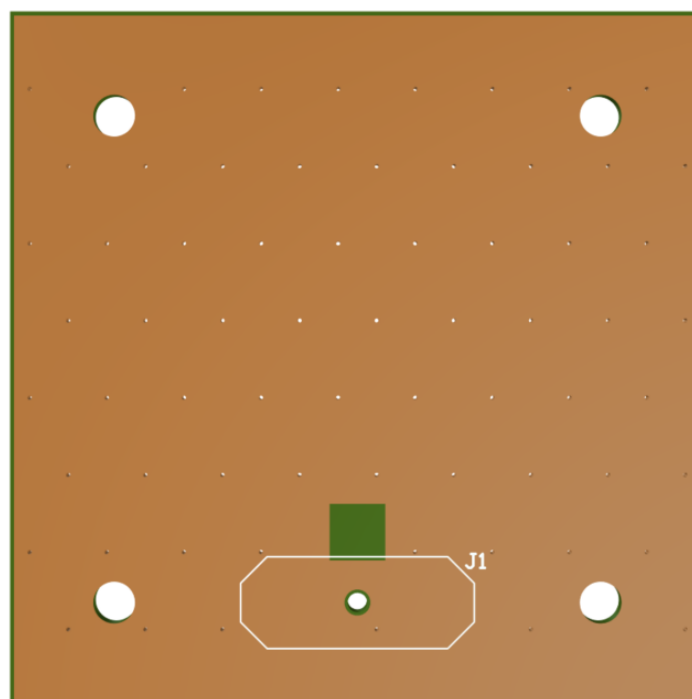

Bottom Side

7.4 Evaluation Board

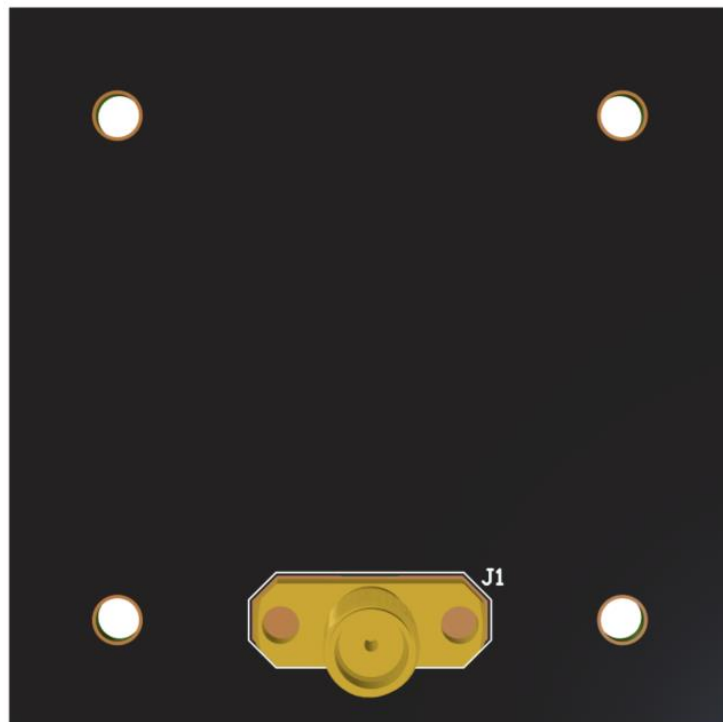
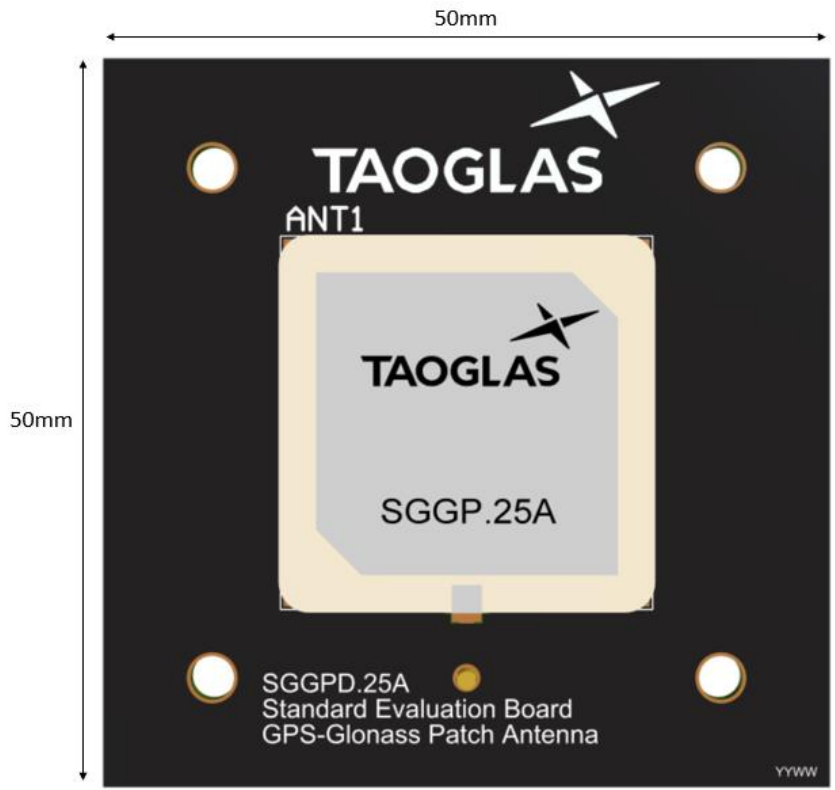

7.5 Footprint

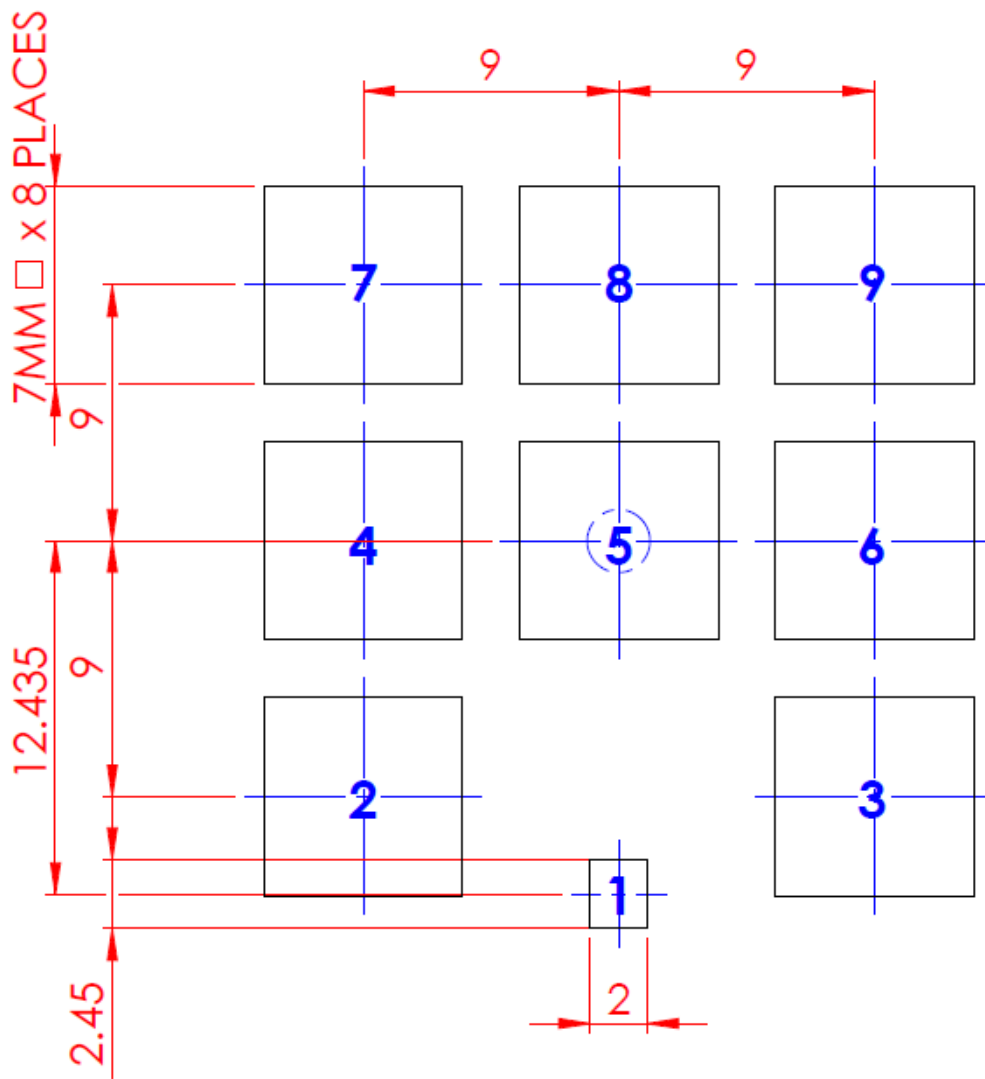

PCB FOOTPRINT

7.6 Copper Keep-Out

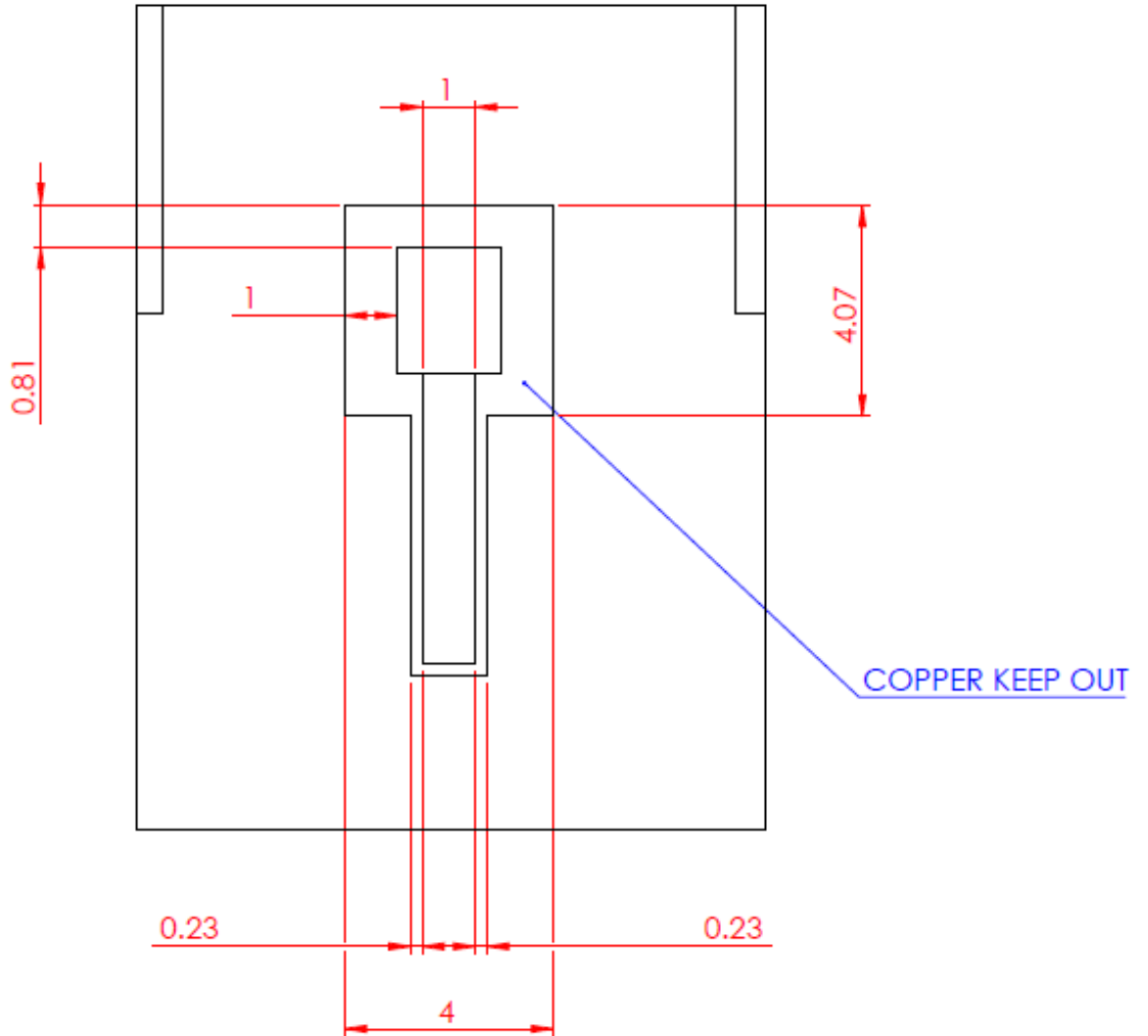

7.7 Top Solder Paste

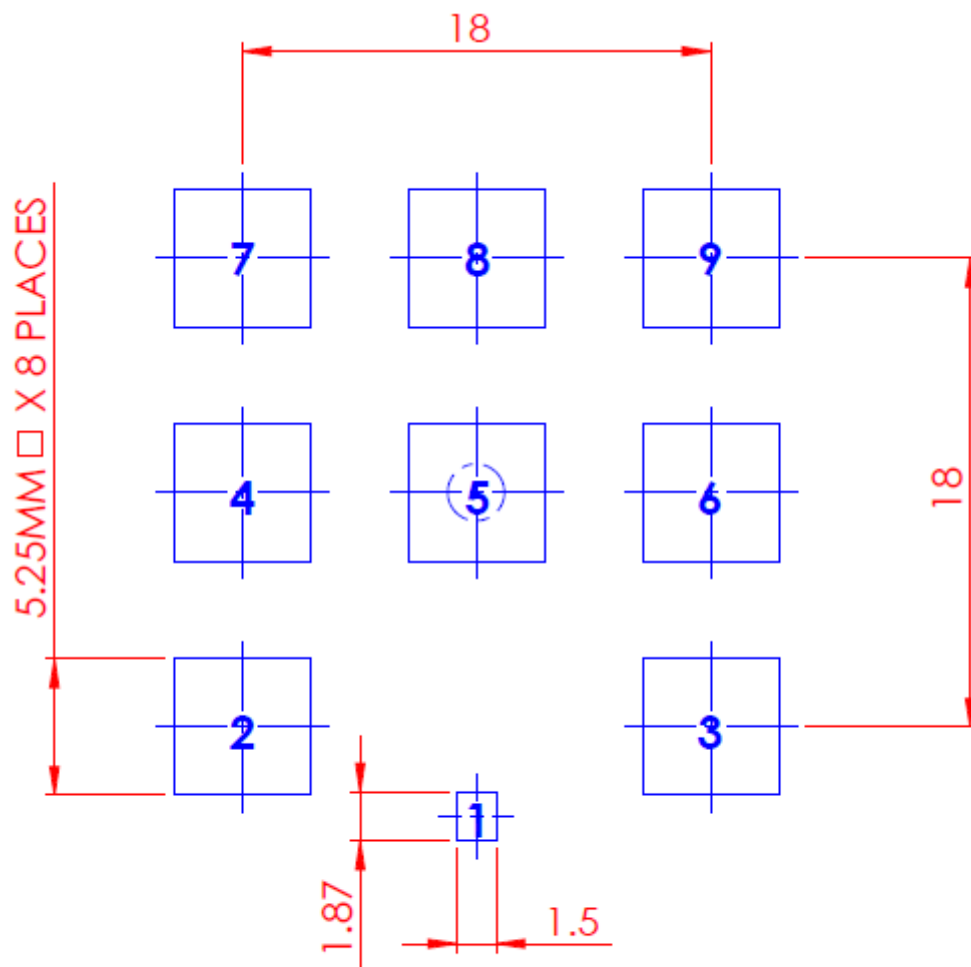

TOP SOLDER PASTE

8. Solder Reflow Profile

The SGGP.25.4.A.02 can be assembled by following the recommended soldering temperatures are as follows:

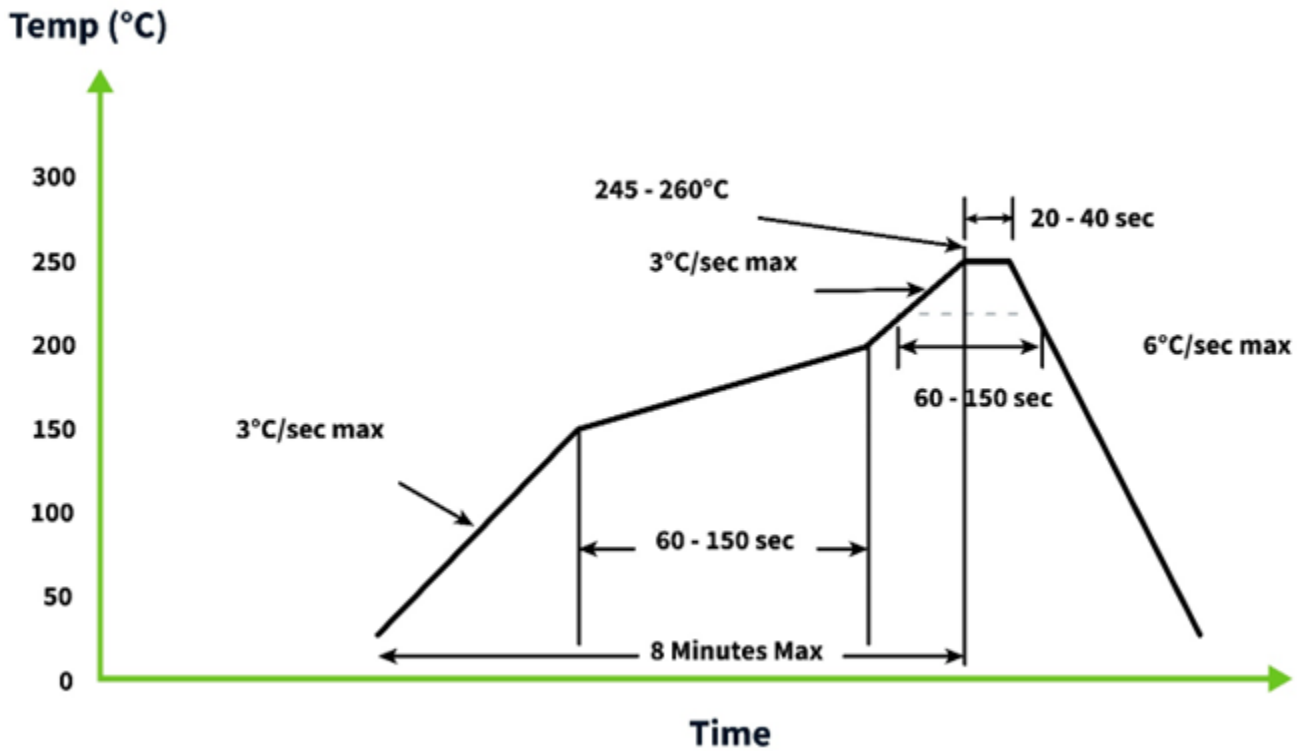

*Temperatures listed within a tolerance of +/- 10° C

Smaller components are typically mounted on the first pass, however, we do advise mounting the SGGP.25.4.A.02 when placing larger components on the board during subsequent reflows.

Changelog for the datasheet

SPE-13-8-031 – SGGP.25.4.A.02

Revision: J (Current Version)

| | |
|------------------|-----------------------|
| Date: | 2023-08-16 |
| Changes: | Full datasheet update |
| Changes Made by: | Gary West |

Previous Revisions

Revision: I

| | |
|------------------|------------|
| Date: | 2021-10-15 |
| Changes: | |
| Changes Made by: | Unknown |

Revision: D

| | |
|------------------|--------------------|
| Date: | 2013-10-23 |
| Changes: | Amended dimensions |
| Changes Made by: | Aine Doyle |

Revision: H

| | |
|------------------|--------------------------------------|
| Date: | 2018-06-25 |
| Changes: | Adding plots and updating footprints |
| Changes Made by: | Jack Conroy |

Revision: C

| | |
|------------------|-----------------------------------|
| Date: | 2013-05-21 |
| Changes: | Removed footprint drawing for now |
| Changes Made by: | Aine Doyle |

Revision: G

| | |
|------------------|----------------------|
| Date: | 2014-05-21 |
| Changes: | Added updated reflow |
| Changes Made by: | Aine Doyle |

Revision: B

| | |
|------------------|-----------------|
| Date: | 2013-05-15 |
| Changes: | Amended Drawing |
| Changes Made by: | Aine Doyle |

Revision: F

| | |
|------------------|--------------------------|
| Date: | 2014-03-27 |
| Changes: | Added Footprint from Jon |
| Changes Made by: | Aine Doyle |

Revision: A (Original First Release)

| | |
|---------|------------|
| Date: | 2013-04-16 |
| Notes: | |
| Author: | SS |

Revision: E

| | |
|------------------|-----------------|
| Date: | 2013-12-03 |
| Changes: | Amended op temp |
| Changes Made by: | Aine Doyle |





www.taoglas.com



Looking for pricing, stock, or lifecycle information?

Click below to explore more details on WIN SOURCE:

-  [View SGGP.25.4.A.02 on WIN SOURCE](#)
-  [Taoglas Limited Information](#)

Optimize Your Supply Chain with WIN SOURCE Solutions

-  Global Sourcing Solution
-  Obsolete Management
-  Cost Control Management
-  Shortage Management
-  Alternative Solution
-  Excess Inventory Management