



**THE DATASHEET OF
SGGP.18.4.A.08**





TAOGLAS®



Datasheet

GPS/GLONASS/Galileo SMD Patch Antenna

Part No:
SGGP.18.4.A.08

Description

18*18*4mm GPS/GLONASS/Galileo SMD Patch Antenna

Features:

SMD Direct Mount Ceramic Patch Antenna
GPS/Galileo/GLONASS Antenna
GPS L1/Galileo E1 (1575.42 MHz) – 50% Efficiency
GLONASS L1 (1602 MHz) – 73% Efficiency
Dimensions: 18*18*4mm
RoHS & Reach Compliant

1.	Introduction	3
2.	Specification	4
3.	Mechanical Drawing	6
4.	Antenna Integration Guide	7
5.	Solder Reflow Profile	14
6.	Packaging	15
7.	Antenna Characteristics	17
8.	Radiation Patterns	21
<hr/>		
	Changelog	24

Taoglas makes no warranties based on the accuracy or completeness of the contents of this document and reserves the right to make changes to specifications and product descriptions at any time without notice. Taoglas reserves all rights to this document and the information contained herein. Reproduction, use or disclosure to third parties without express permission is strictly prohibited.



1. Introduction

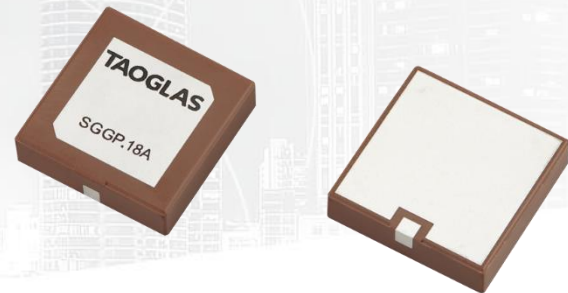

The Taoglas SGGP.18 is a ceramic GPS/GLONASS/Galileo passive patch antenna designed for optimal performance on GPS L1/Galileo E1 band (1575.42 MHz) and GLONASS L1 band (1602 MHz). With a low-profile thickness of just 4mm and convenient mounting via standard SMD process, it is ideal for high-volume assembly applications. SGGP.18 is designed for applications such as navigation devices, vehicle tracking/fleet management systems, and telematics devices. It is an excellent choice for applications in transportation, defense, marine, agriculture, and navigation industries.

This antenna has been tuned for use on a 50mm*50mm ground plane to achieve 3.02 dBi gain at 1575.42MHz and 2.62 dBi gain at 1602MHz. In addition to excellent efficiency, it also offers a broadly hemispherical radiation pattern with stable gain across elevations.

SGGP.18 is manufactured and tested in an IATF16949 first tier automotive approved facility. For further optimization to customer-specific device environments, custom tuned patch antennas can be supplied, subject to NRE and MOQ.

For further information or support with integrating this antenna into your device, please contact your regional Taoglas customer support team.

2. Specification

GNSS Frequency Bands					
GPS	L1 1575.42 MHz	L2 1227.6 MHz	L5 1176.45 MHz		
	■	□	□		
GLONASS	G1 1602 MHz	G2 1248 MHz	G3 1207 MHz		
	■	□	□		
Galileo	E1 1575.24 MHz	E5a 1176.45 MHz	E5b 1201.5 MHz	E6 1278.75 MHz	
	■	□	□	□	
BeiDou	B1C 1575.42 MHz	B1I 1561 MHz	B2a 1176.45 MHz	B2b 1207.14 MHz	B3 1268.52 MHz
	■	□	□	□	□
L-Band	L-Band 1542 MHz				
	□				
QZSS (Regional)	L1 1575.42 MHz	L2C 1227.6 MHz	L5 1176.45 MHz	L6 1278.75e6	
	■	□	□	□	
IRNSS (Regional)	L5 1176.45 MHz				
	□				
SBAS	L1/E1/B1 1575.42 MHz	L5/B2a/E5a 1176.45 MHz	G1 1602 MHz	G2 1248 MHz	G3 1207 MHz
	■	□	■	□	□

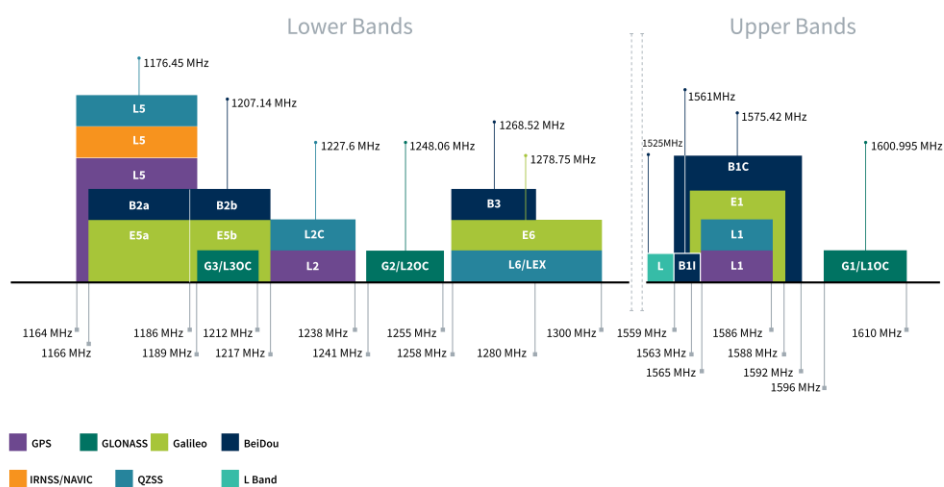

GNSS Bands and Constellations

Electrical		
Frequency (MHz)	1575.42	1603
VSWR (max.)	2:1	2:1
Passive Antenna Efficiency	50.46	73.63
Passive Antenna Gain at Zenith (dBic)	3.02	2.62
Polarization	RHCP	
Impedance	50 Ω	
Tested on 50*50mm ground plane		

Mechanical	
Ceramic Dimension	18*18*4mm
Weight	5.8g

Environmental	
Operation Temperature	-40°C to 85°C
Humidity	Non-condensing 65°C 95% RH
Moisture Sensitivity Level (MSL)	3(168 Hours)

3. Mechanical Drawing

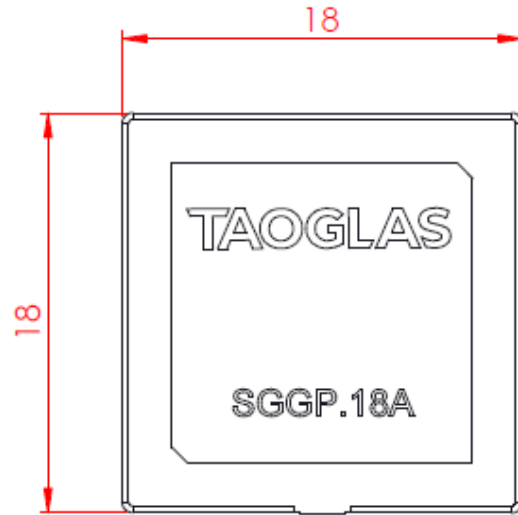

TOP VIEW

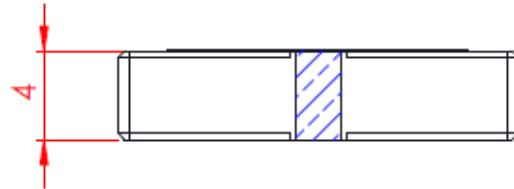

FRONT VIEW

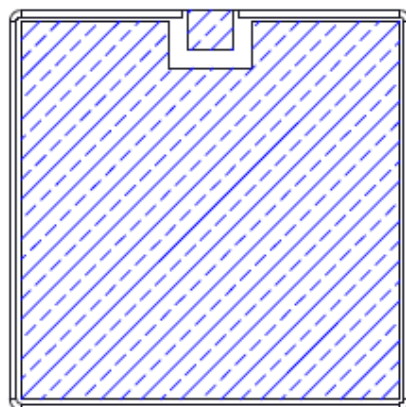

BOTTOM VIEW

4. Antenna Integration Guide

The following is an example on how to integrate the SGGP.18.4.A.08 into a design. This antenna has nine pins, one pin is used for the RF Feed. Taoglas recommends using a minimum of 50x50mm ground plane (PCB) to ensure optimal performance.



Top view of PCB.

Please find the Integration files in Altium, 2D formats and the 3D model for the SGGP.18.4.A.08 here:
<https://www.taoglas.com/product/ssggp-18-4-a-08-gps-glonass-galileo-smd-18184mm-mount-patch/>

4.1 Schematic and Symbol Definition



Above is the 3D model of the SGGP.18.4.A.08 on the PCB.

The circuit symbol for the SGGP.18.4.A.08 is shown below. The antenna has 9 pins as indicated below.

Pin	Description
1	RF Feed
2, 3, 4, 5, 6, 7, 8, 9	Ground

TAOGLAS_SGGP.18.4.A.08
ANT1

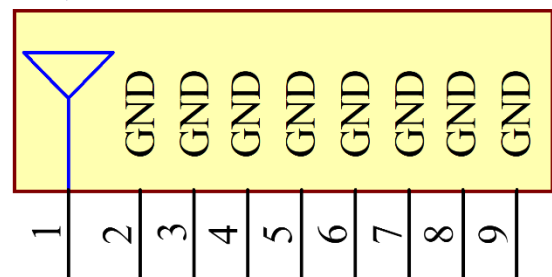

Above is a schematic symbol of SGGP.18.4.A.08 and a table of the pin definitions.

4.2 Antenna Footprint

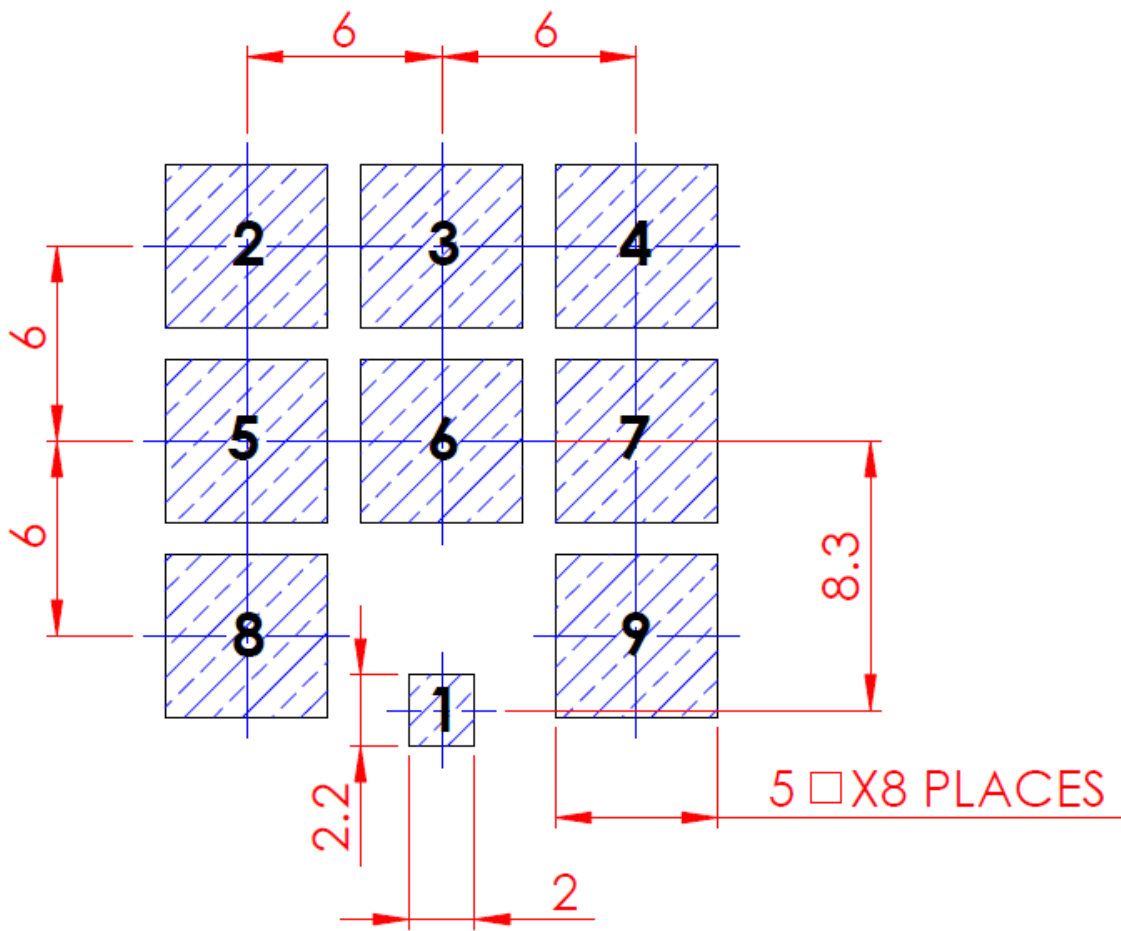

PCB FOOTPRINT

Pin	Description
1	RF Feed
2, 3, 4, 5, 6, 7, 8, 9	Ground

4.3 Top Solder Paste

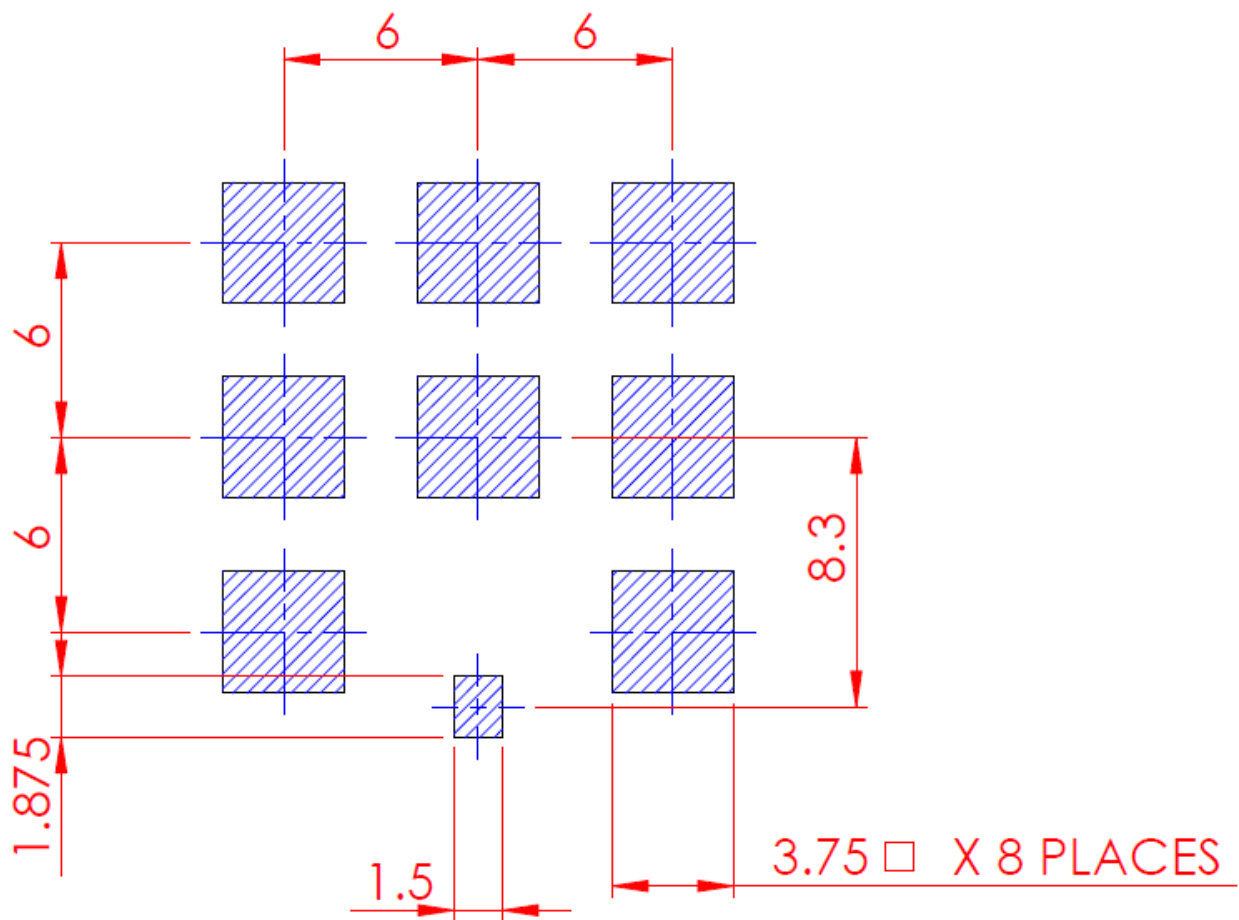

TOP SOLDER PASTE

4.4 Copper Clearance for SGGP.18.4.A.08

The footprint and clearance on the PCB must comply with the antenna's specification. The PCB layout shown in the diagrams below demonstrates the SGGP.18.4.A.08 clearance area for Pin 1 (RF Feed Pad). The copper keep out area applies all layers beneath the antenna.

There should be a 3x4mm copper clearance area around the antenna feed pad on the top side of the PCB.

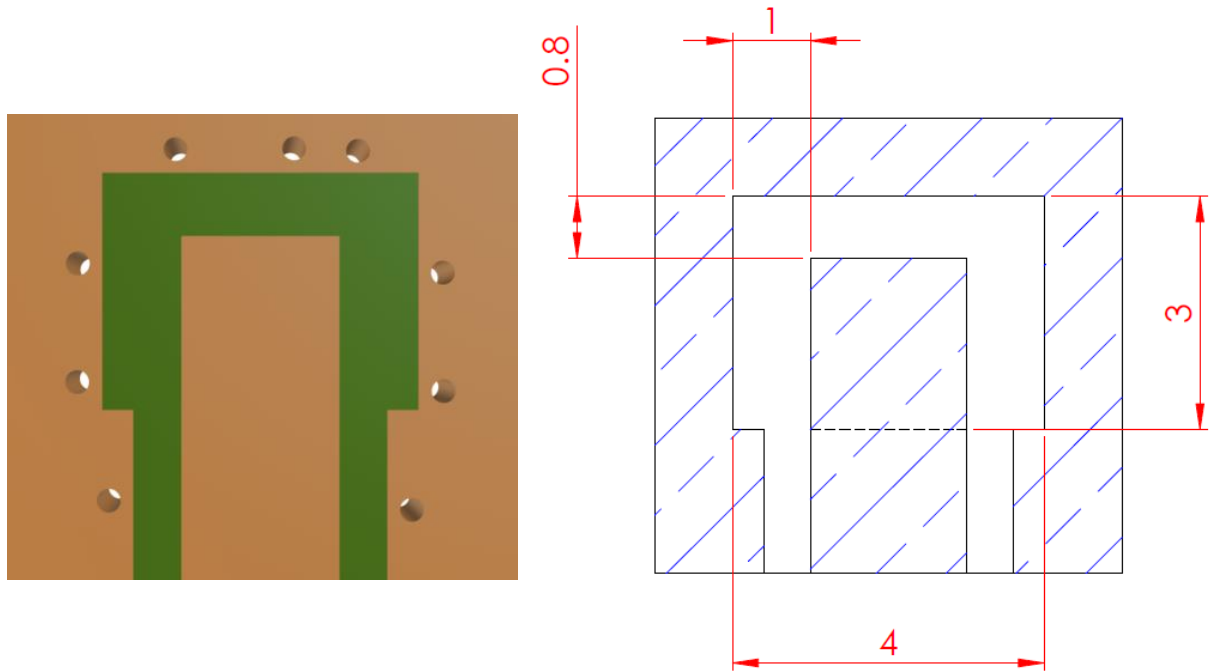

Copper Clearance for Pin 1 (RF Feed Pad) of the SGGP.18.4.A.08.

4.5 Antenna Integration

The SGGP.18.4.A.08 should be placed in the centre of the PCB to take advantage of the ground plane. The RF trace must maintain a 50 Ohm transmission line. Ground vias should be placed around the transmission line and copper clearance area.



Top view of the PCB, showing transmission line and integration notes.

4.6 Evaluation Board Ground Plane Length

The image shown below highlights the transmission line of the antenna. Taoglas recommends using a minimum of 50x50mm ground plane (PCB) to ensure optimal performance.



Top Side (SGGP.18.4.A.08 placement on 50x50mm PCB)

5. Solder Reflow Profile

The SGGP.18.4.A.08 can be assembled by following the recommended soldering temperatures are as follows:

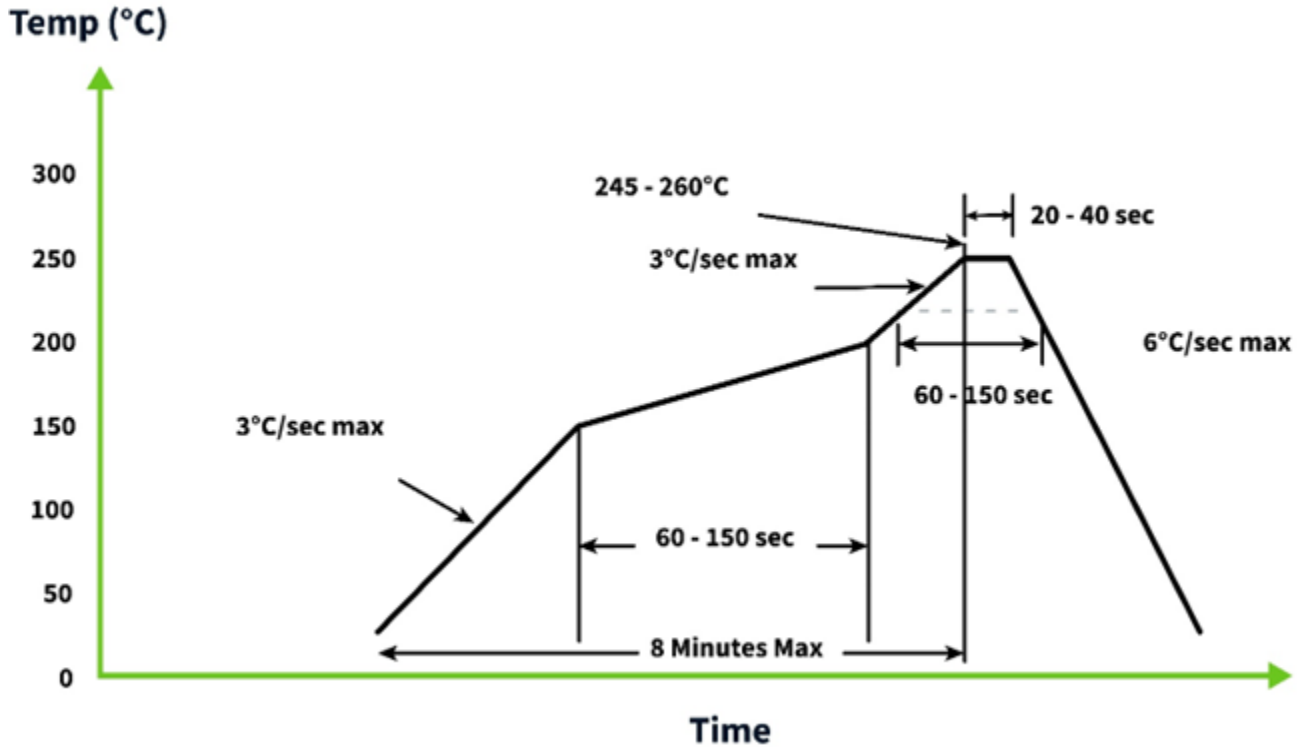

*Temperatures listed within a tolerance of +/- 10° C

Smaller components are typically mounted on the first pass, however, we do advise mounting the SGGP.18.4.A.08 when placing larger components on the board during subsequent reflows.

Note: Soldering flux classified ROL0 under IPC J-STD-004 is recommended.

6. Packaging

200 pc SGGP.18.4.A.08 per reel
 Dimensions - Ø330*33mm
 Weight - 2.125Kg

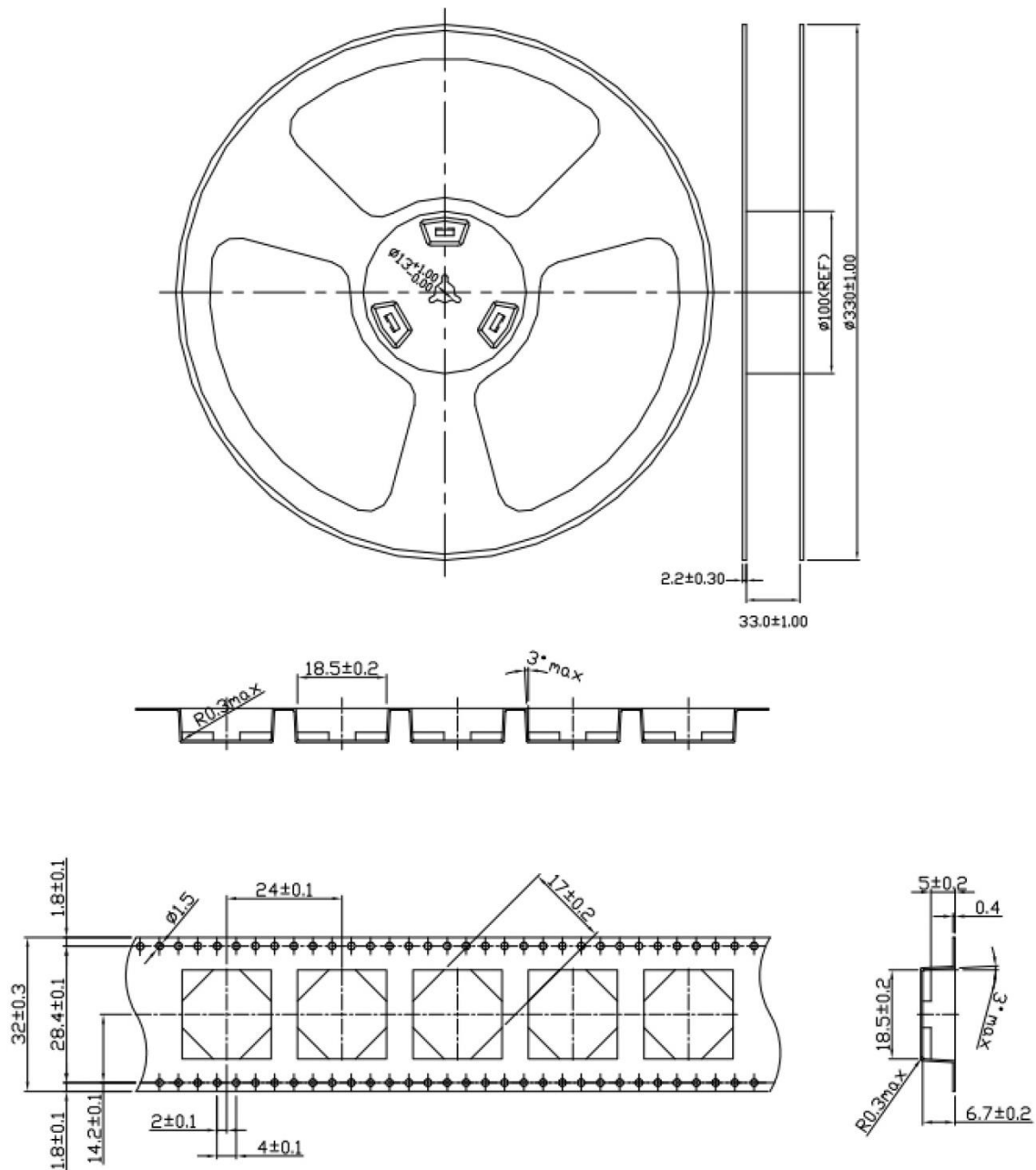

200 pc SGGP.18.4.A.08 per small box
Dimensions - 350*340*67mm
Weight - 2.125Kg

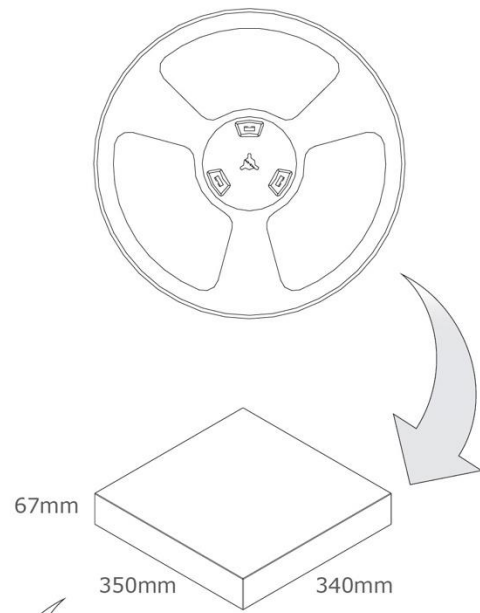

800 pcs SGGP.18.4.A.08 per carton
Dimensions - 370*360*305mm
Weight - 8.5Kg

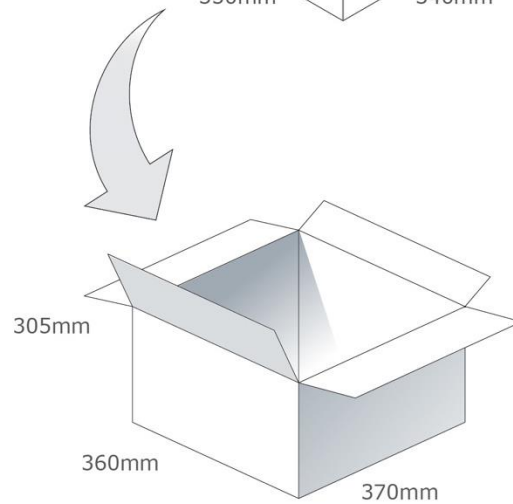

7. Antenna Characteristics

7.1 Test Setup

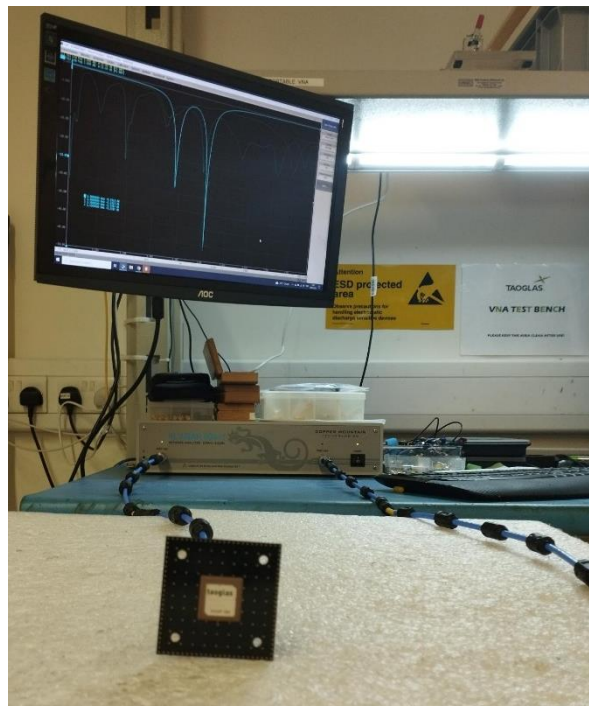
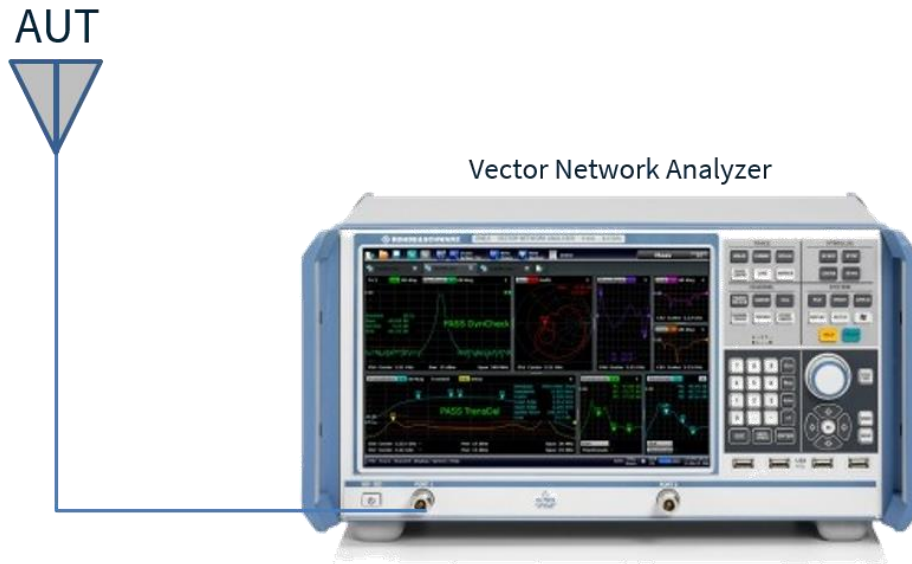

VNA Test Set-up

7.2 Return Loss

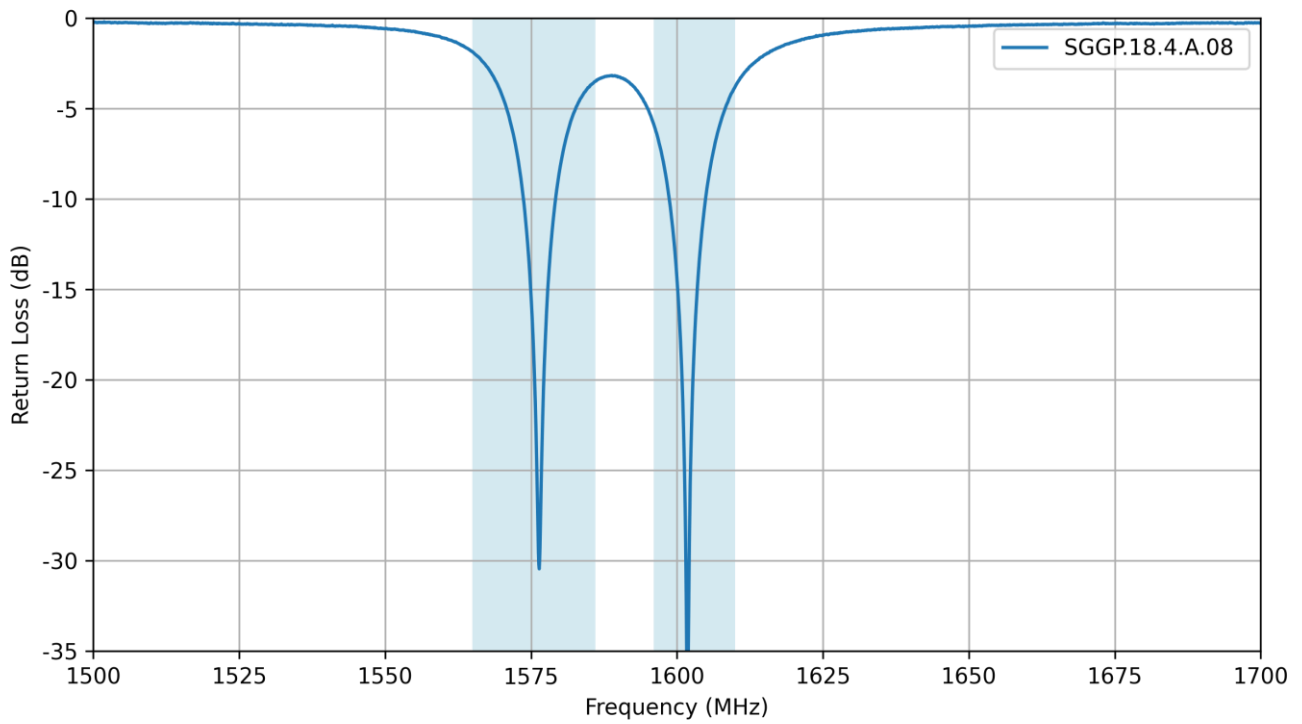

7.3 VSWR

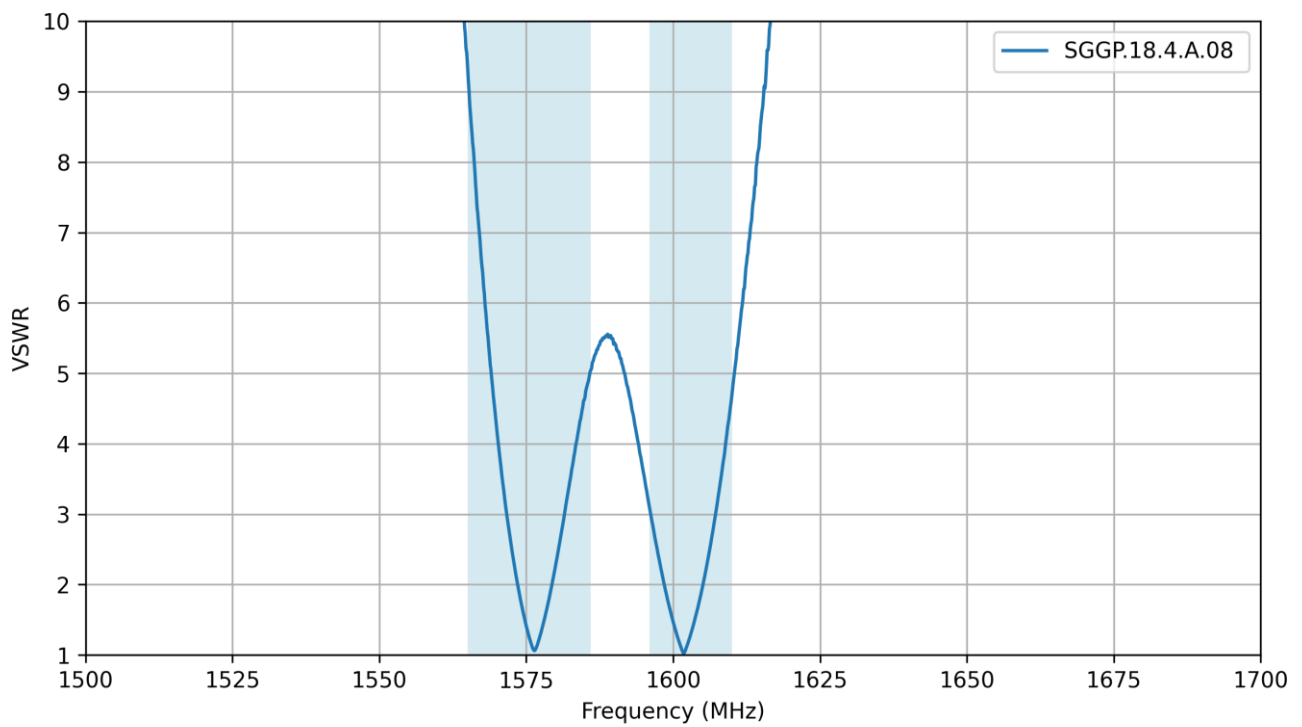

7.4 Efficiency

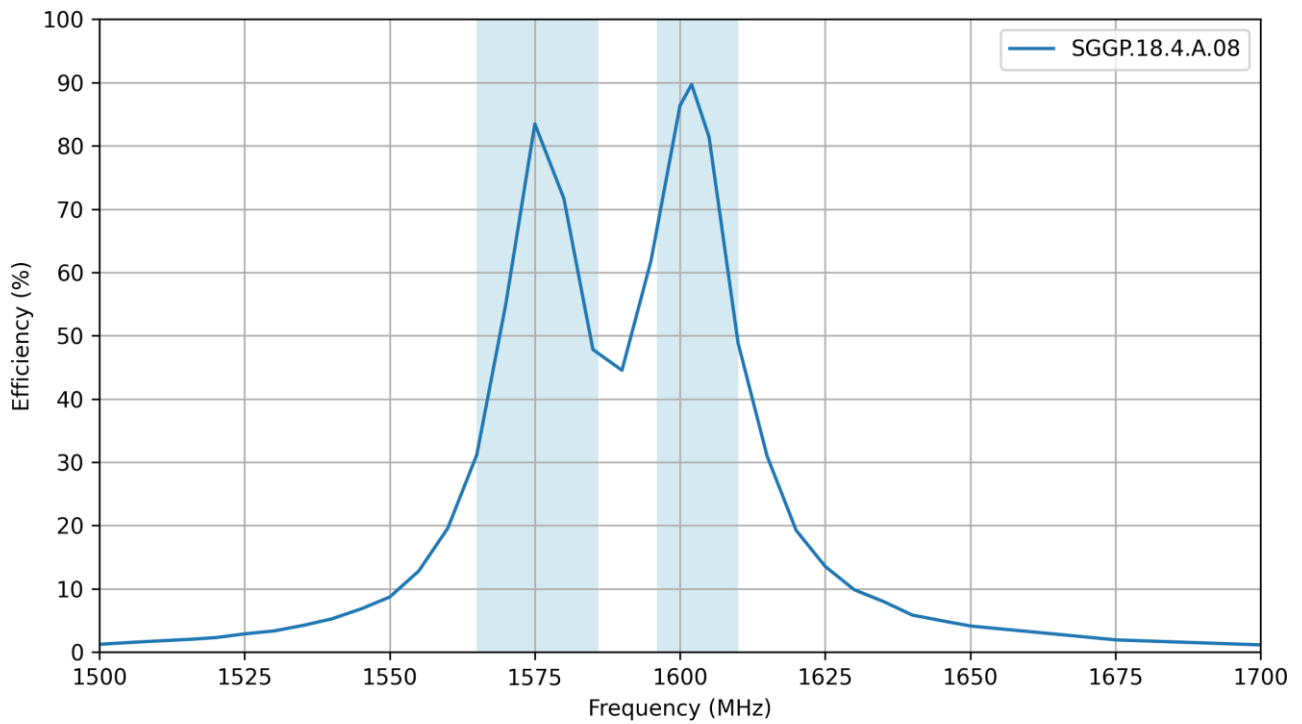

7.5 Average Gain

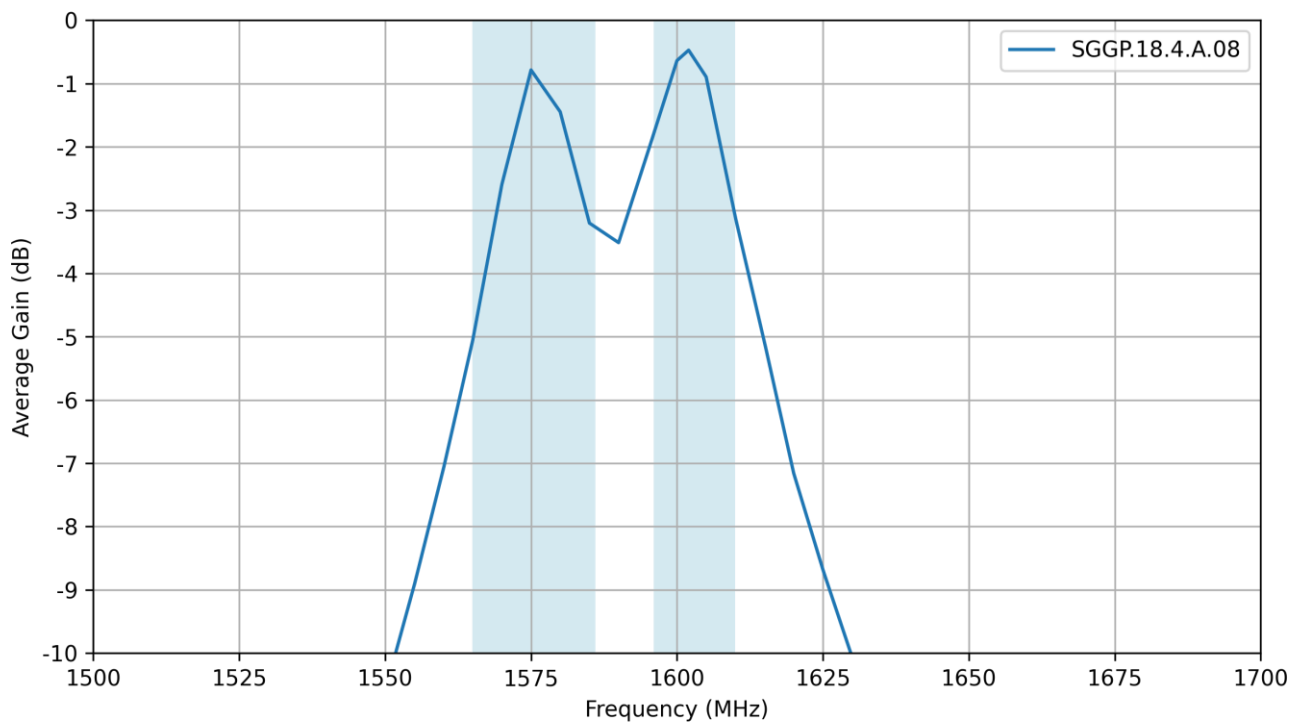

7.6 Peak Gain

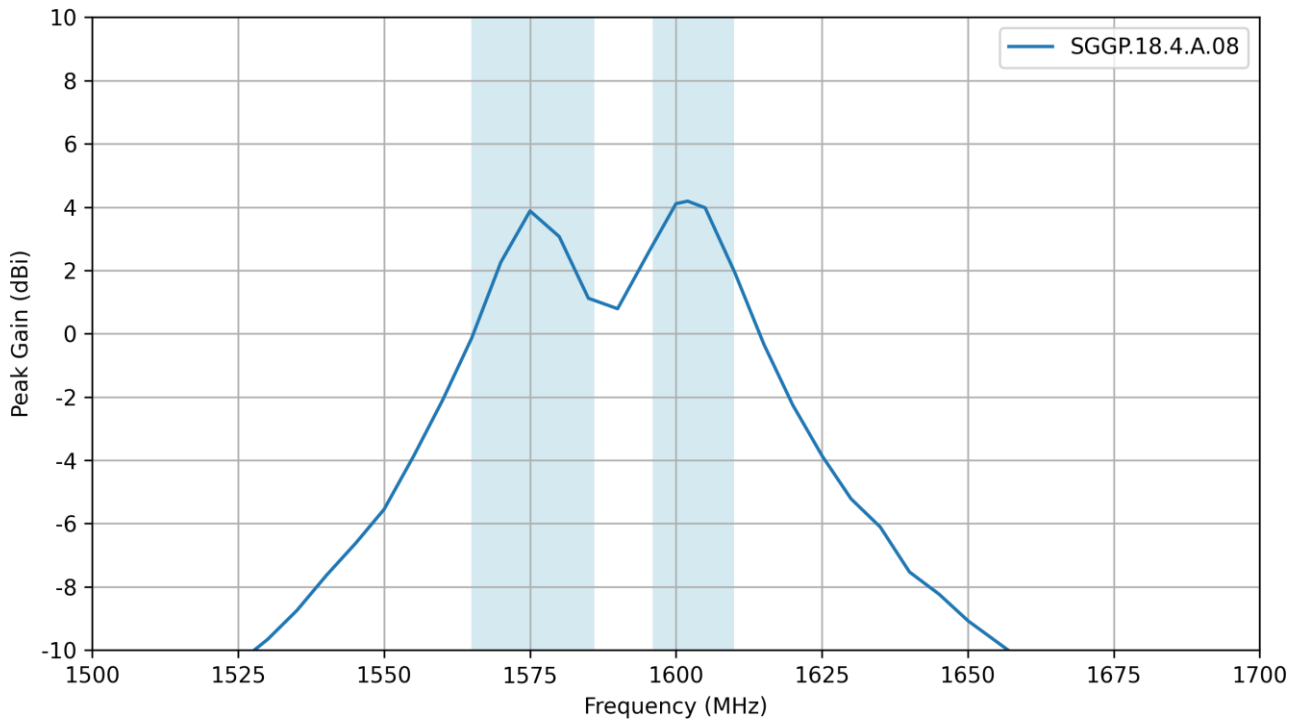

8. Radiation Patterns

8.1 Test Setup

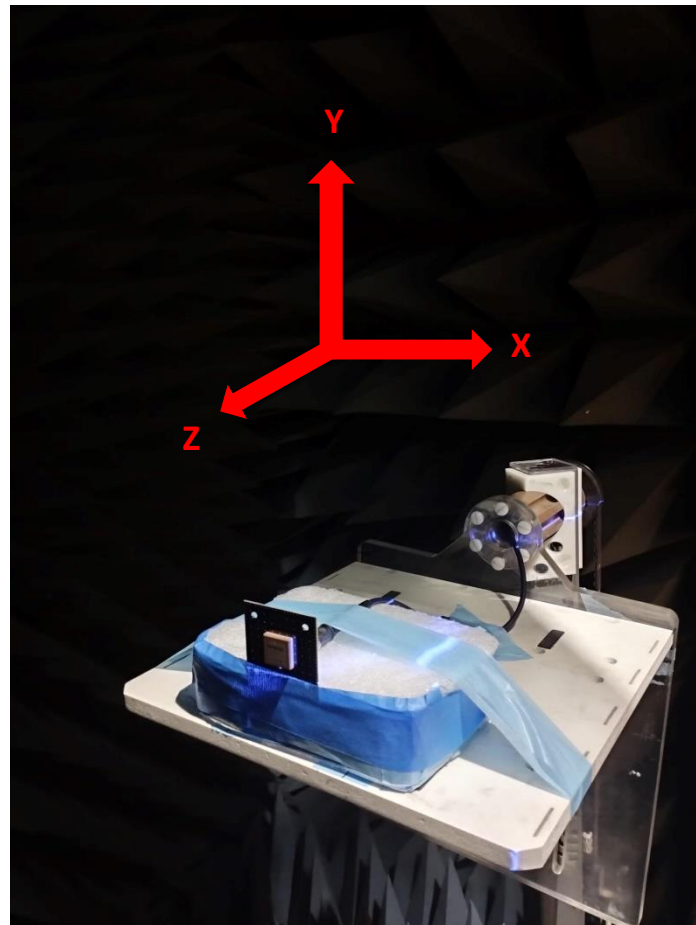
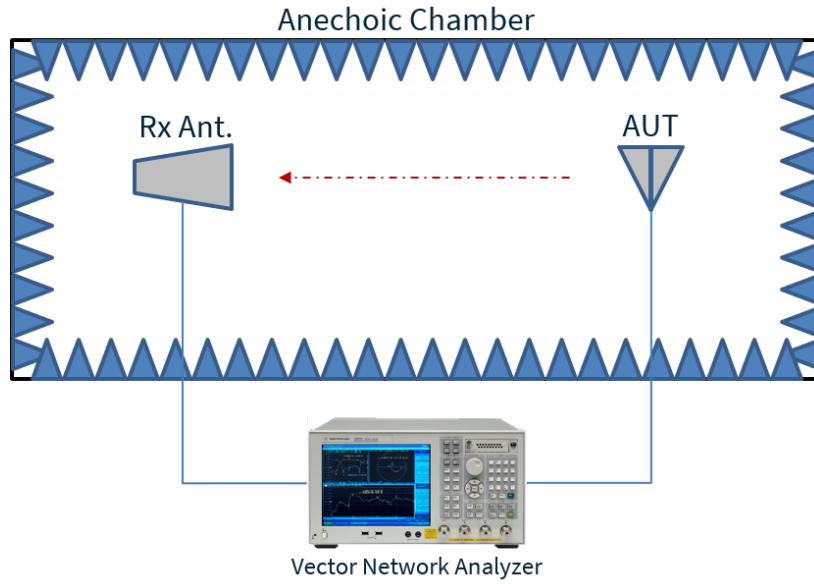

Chamber Test Set-up

8.2 Patterns at 1575 MHz

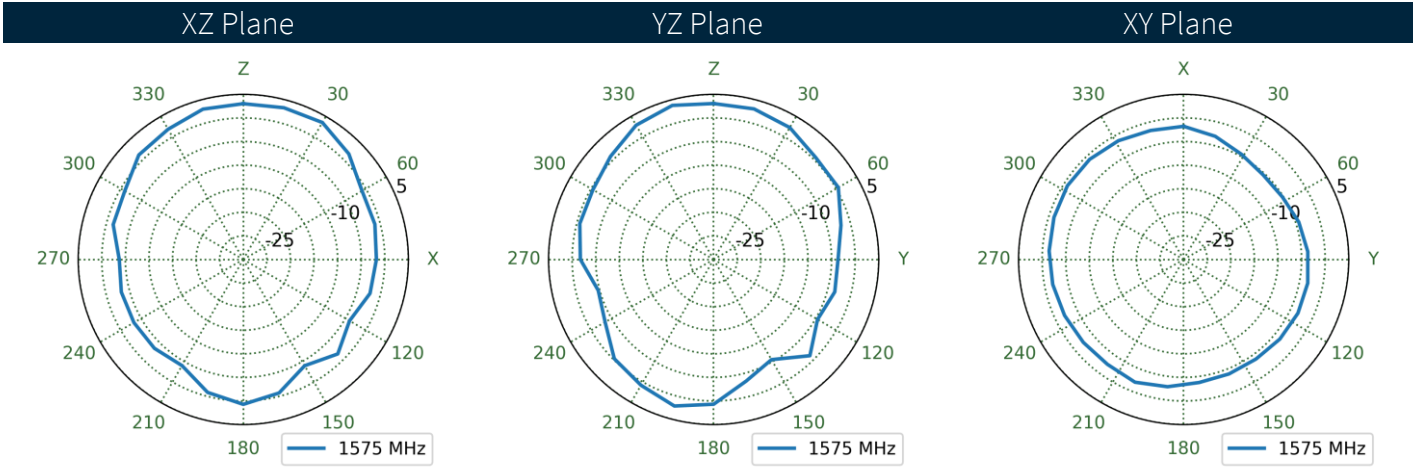
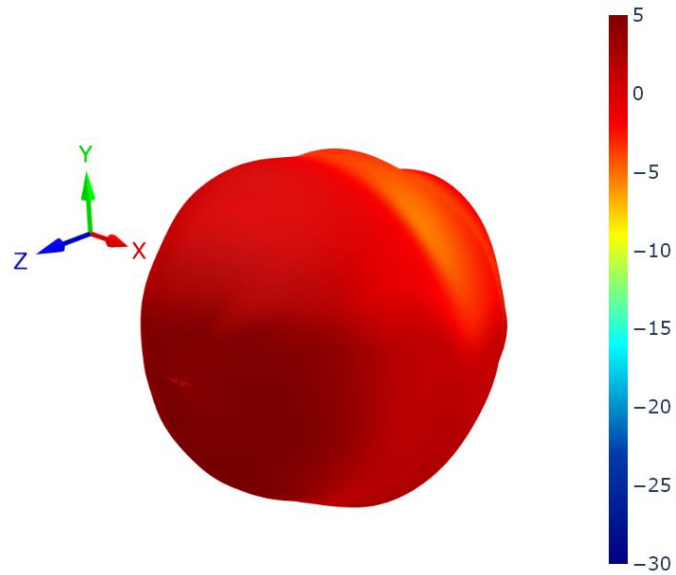

8.3 Patterns at 1602 MHz

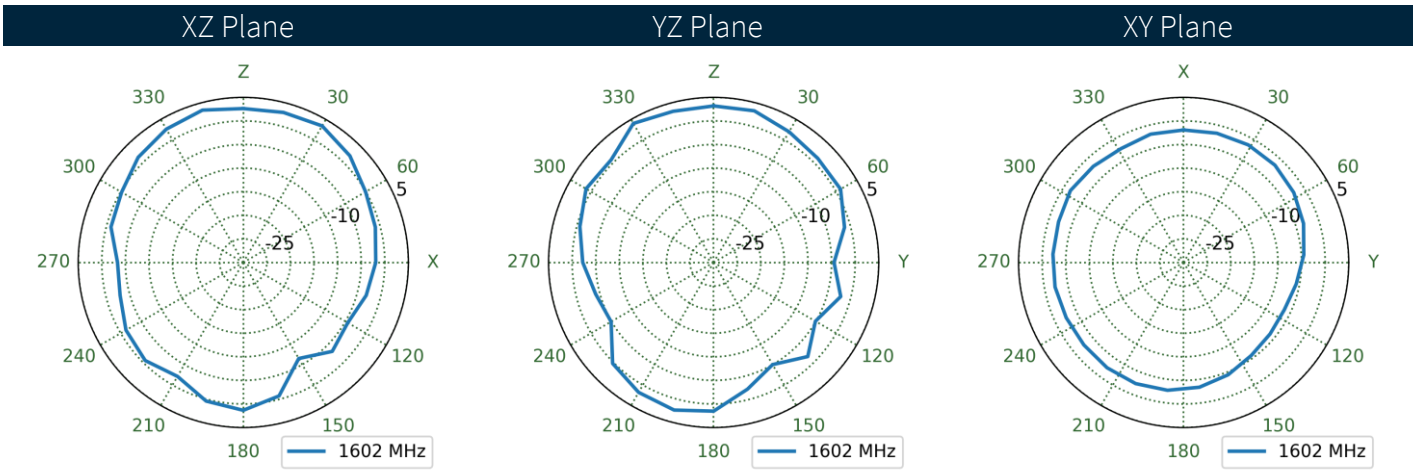
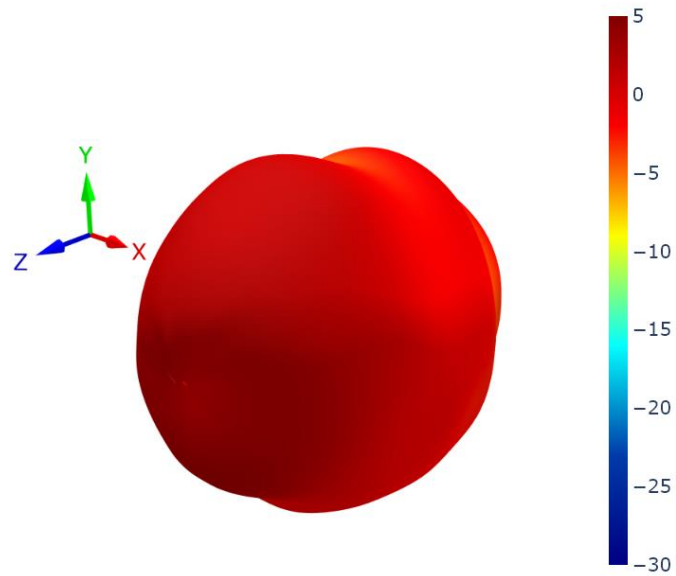

Changelog for the datasheet

SPE-18-8-067 - SGGP.18.4.A.08

Revision: G (Current Version)

Date:	2024-02-26
Changes:	Full datasheet update including flow update.
Changes Made by:	Gary West

Previous Revisions

Revision: F

Date:	2023-01-05
Changes:	Updated Solder Reflow Information.
Changes Made by:	Cesar Sousa

Revision: A (Original First Release)

Date:	2018-07-02
Notes:	First Release
Author:	MC

Revision: E

Date:	2023-01-05
Changes:	Updated PCB Mechanical Footprint Drawing & Integration Guide.
Changes Made by:	Gary West

Revision: D

Date:	2023-01-05
Changes:	Updated PCB Keep Out Drawing
Changes Made by:	Gary West

Revision: C

Date:	2022-05-27
Changes:	Added dimension to footprint drawing between pad 1 and 5.
Changes Made by:	Gary West

Revision: B

Date:	2021-10-20
Changes:	Full datasheet template update, Addition of MSL to spec table & Integration guide.
Changes Made by:	Gary West





www.taoglas.com



Looking for pricing, stock, or lifecycle information?

Click below to explore more details on WIN SOURCE:

-  [View SGGP.18.4.A.08 on WIN SOURCE](#)
-  [Taoglas Limited Information](#)

Optimize Your Supply Chain with WIN SOURCE Solutions

-  Global Sourcing Solution
-  Obsolete Management
-  Cost Control Management
-  Shortage Management
-  Alternative Solution
-  Excess Inventory Management