



**THE DATASHEET OF  
SXP.22.4.A.02**





# TAOGLAS®



## Datasheet

**Part No.:**

**SXP.22.4.A.02**

**Description:**

2320 ~ 2345MHz SDARS 22mm Patch Antenna  
(Satellite Digital Audio Radio System)

**Features:**

22\*22\*4mm Ceramic patch  
Excellent Efficiency: >88%  
High Gain (Up to 9.6 dBiC at Zenith)  
Optimized LHCP Radiation Pattern  
Pin & Adhesive Mounting  
Manufactured in an IATF16949 Approved Facility  
RoHS & REACH Compliant

1. Introduction	3
2. Specifications	4
3. Antenna Characteristics	5
4. 2D Radiation Patterns	8
5. 3D Radiation Patterns	10
6. Mechanical Drawing	11
7. PCB Footprint Recommendation	12
8. Packaging	13

Taoglas makes no warranties based on the accuracy or completeness of the contents of this document and reserves the right to make changes to specifications and product descriptions at any time without notice. Taoglas reserves all rights to this document and the information contained herein.

Reproduction, use or disclosure to third parties without express permission is strictly prohibited.

Copyright © Taoglas Ltd.



# 1. Introduction



The Taoglas SXP.22.4.A.02 is part of a series of patch antennas designed for use with Satellite Digital Audio Radio Services (SDARS). It features left-hand circular polarization and excellent gain characteristics in the 2320 to 2345 MHz band, making it compatible with the most popular satellite radio services available in many new vehicles.

The SXP.22 comes in a convenient, compact form factor, with dimensions of just 22mm x 22mm x 4mm, and is manufactured with high-quality ceramic. It is mounted via pin and 3M adhesive tape.

For further optimization to customer-specific device environments, custom tuned patch antennas can be supplied. Your regional Taoglas sales office can help you identify the best patch antenna for your specific SDARS application.

## 2. Specifications

ELECTRICAL	
Frequency	SIRIUS : 2326.25 MHz $\pm$ 6.25 MHz XM : 2338.75 MHz $\pm$ 6.25 MHz
Centre Frequency	2332.5 MHz $\pm$ 12.5 MHz
Return Loss	SIRIUS: -10 dB max. XM: -10 dB max.
Zenith Gain	SIRIUS: +9 dBiC typ. XM: +9.6 dBiC typ.
Efficiency	SIRIUS: 88 % XM: 89 %
Polarization	LHCP
Impedance	50 $\Omega$
MECHANICAL	
Dimensions	22 x 22 x 4mm
Material	Ceramic
Pin Diameter	0.9mm
Pin Length	2.4mm
Weight	6.9g
ENVIRONMENTAL	
Operation Temperature	-40°C to 85°C
Storage Temperature	-40°C to 105°C
Humidity	Non-condensing 65°C 95% RH

\* Antenna properties were measured with the antenna mounted on 70\*70mm Ground Plane

XM Gain Requirements (Satellite) – Ground Plane			
AUT Location	Elevation Angle(degrees)	XM Sirius Limits(dBiC)	Measured Average Gain(dBiC)
Passive Ground Plane	20 $\leq\phi\leq$ 25	0.5	2.9
	25 $\leq\phi\leq$ 30	1	3.8
	30 $\leq\phi\leq$ 50	2	5.2
	50 $\leq\phi\leq$ 70	4	7.4
	70 $\leq\phi\leq$ 90	2	8.7

XM Gain Requirements (Terrestrial) – Ground Plane			
AUT Location	Elevation Angle(degrees)	Antenna Mean Passive VP Gain Over Solid Angle (dBi)	Antenna P/P Gain variation (dB)
Passive Ground Plane	0 $^{\circ}\leq\phi\leq$ 10 $^{\circ}$	-2.45dBi	-
	$\Phi=5^{\circ}$	-	2326.25MHz=1.7 dBiC 2338.75MHz=1.6 dBiC

### 3. Antenna Characteristics

#### 3.1 Return Loss S11

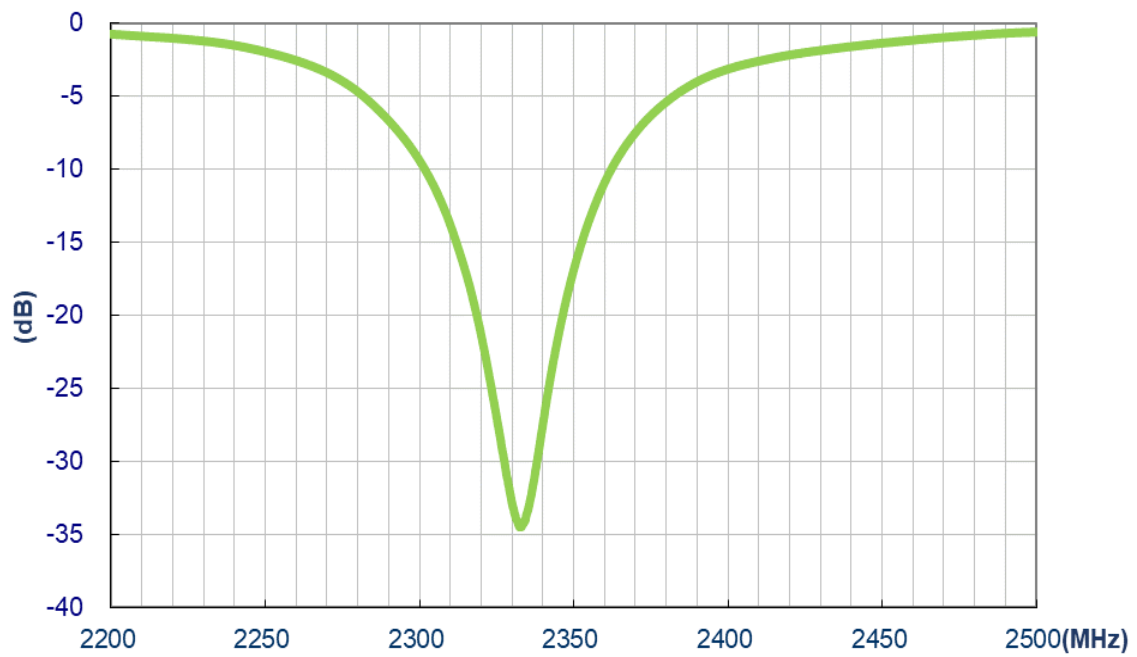

#### 3.2 Efficiency

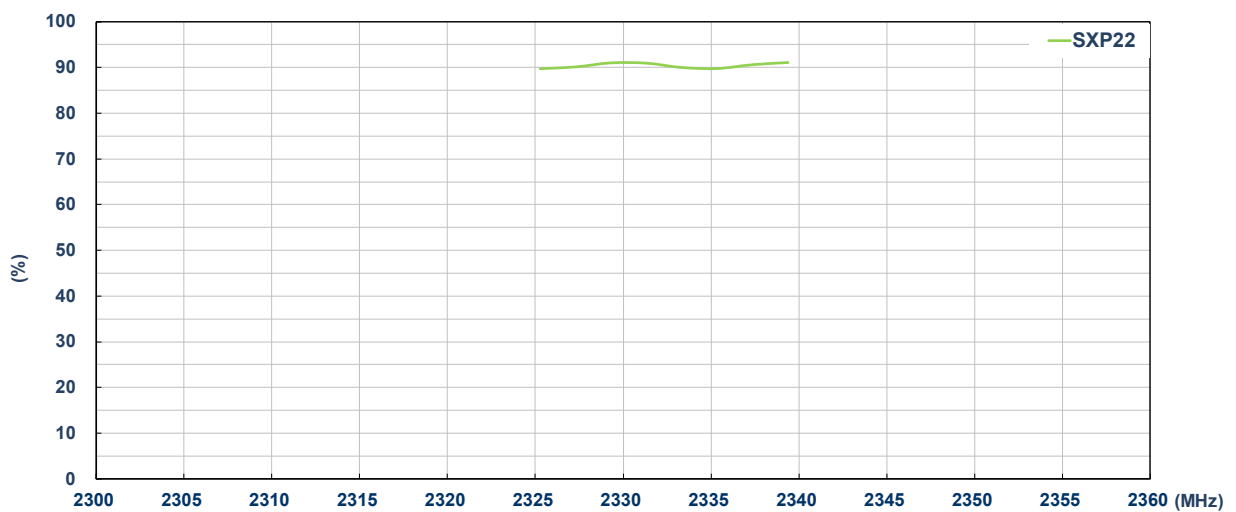

### 3.3 Peak Gain

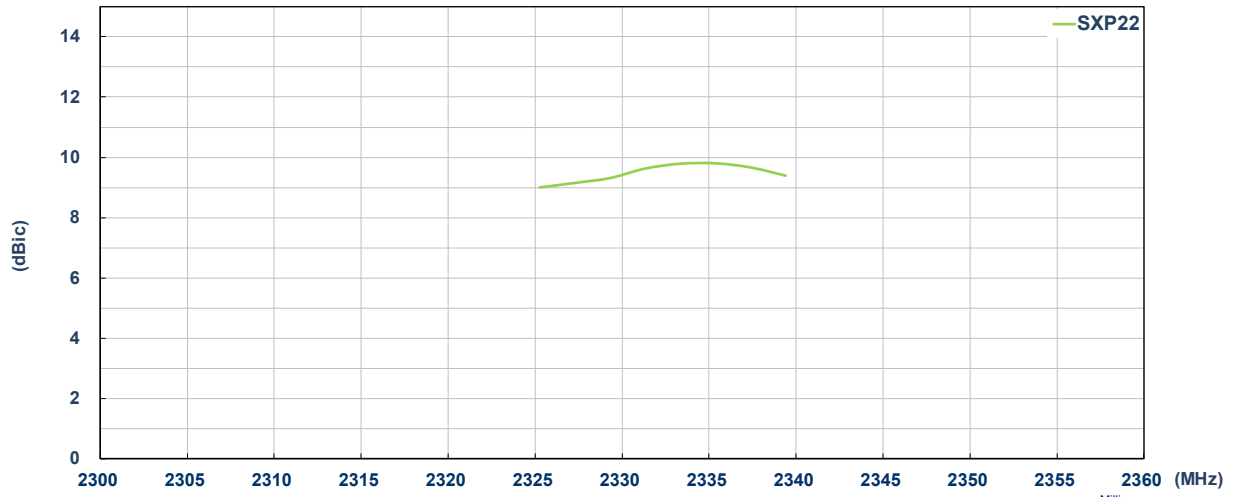

### 3.4 Average Gain

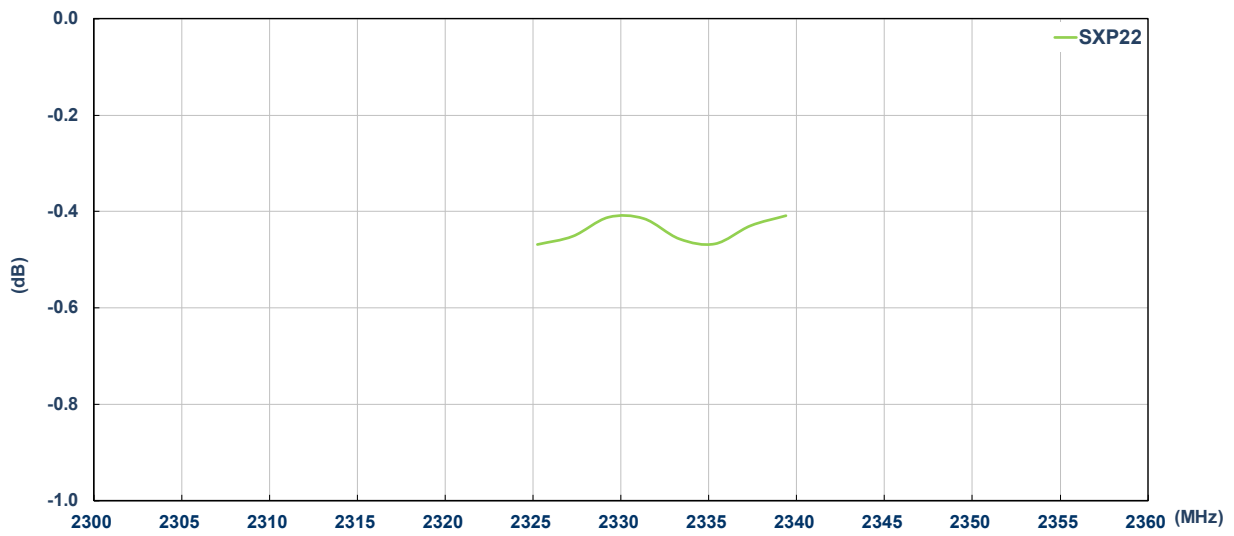

### 3.5 Axial Ratio @ Phi=0°

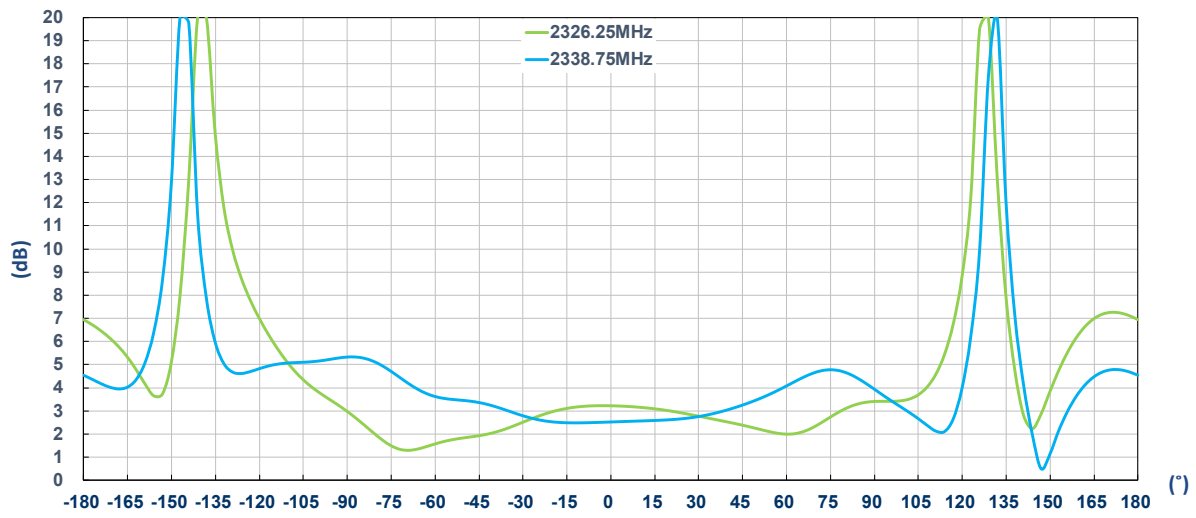

### 3.6 Axial Ratio @ Phi=90°

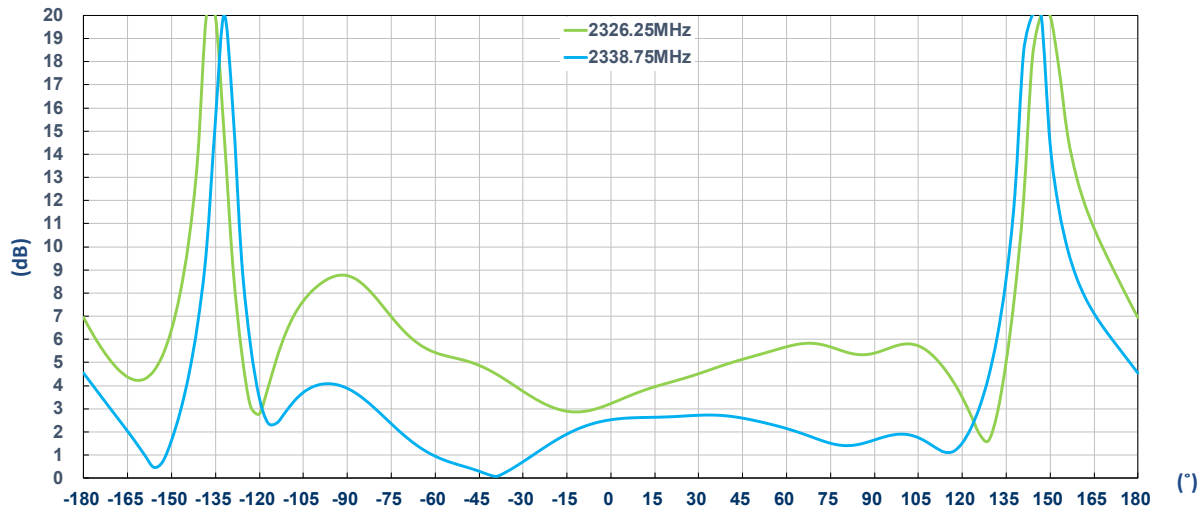

## 4. 2D Radiation Patterns

### 4.1 Test Setup

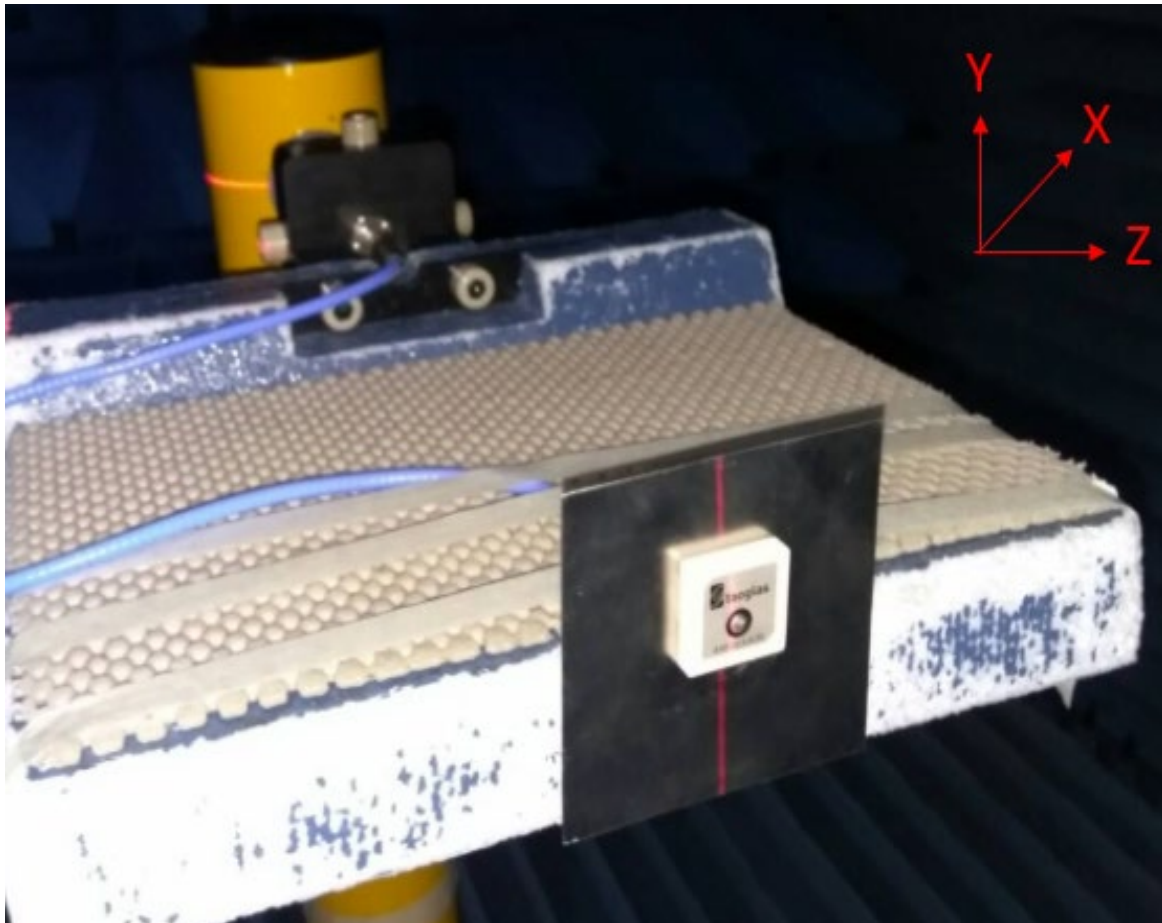

XY Plane

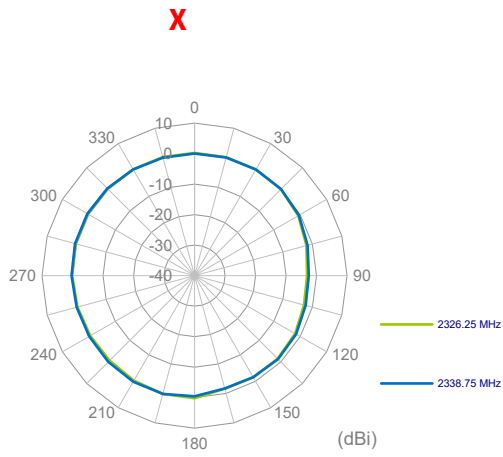

XZ Plane

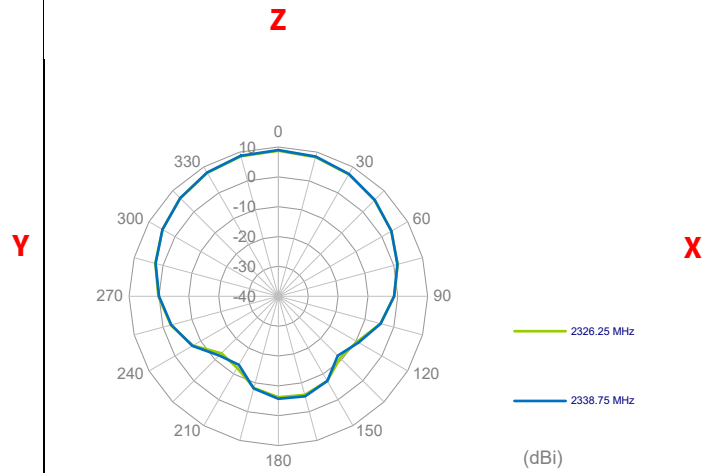

YZ Plane

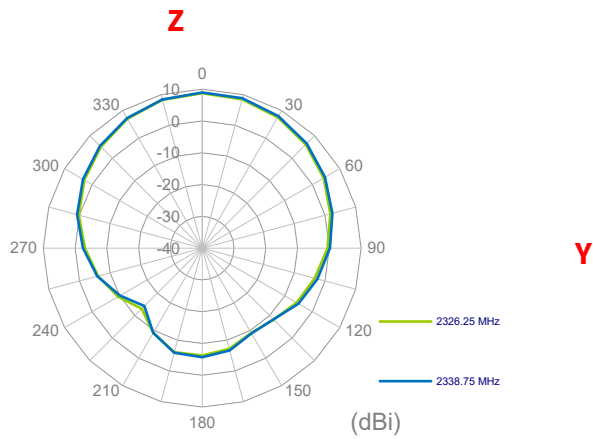

## 5. 3D Radiation Patterns

### 5.1 2326.25MHz

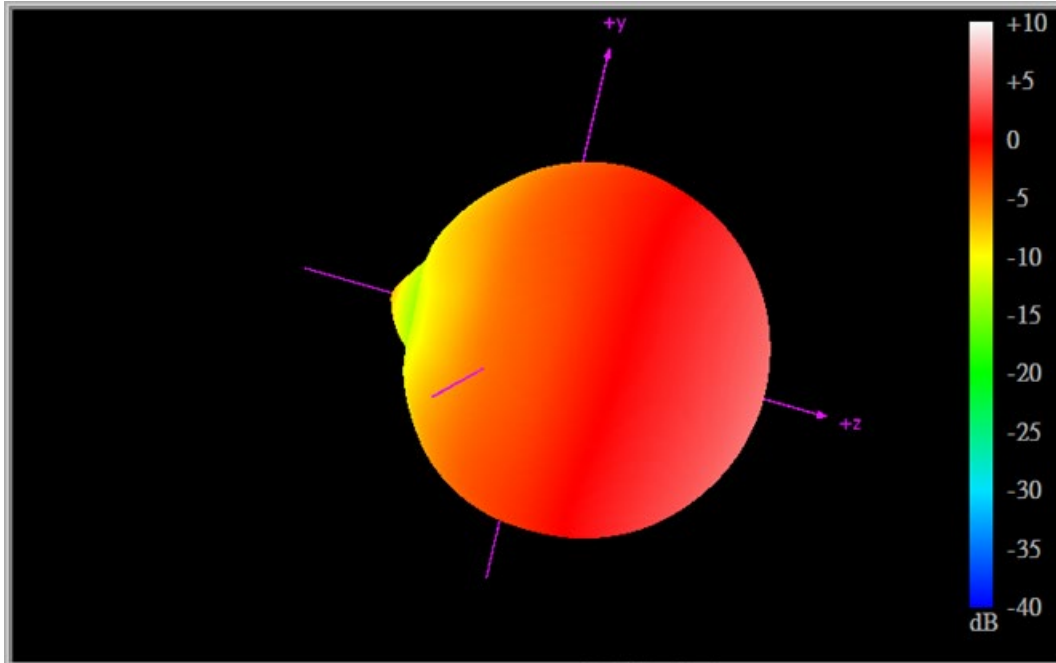

### 5.2 2338.75MHz

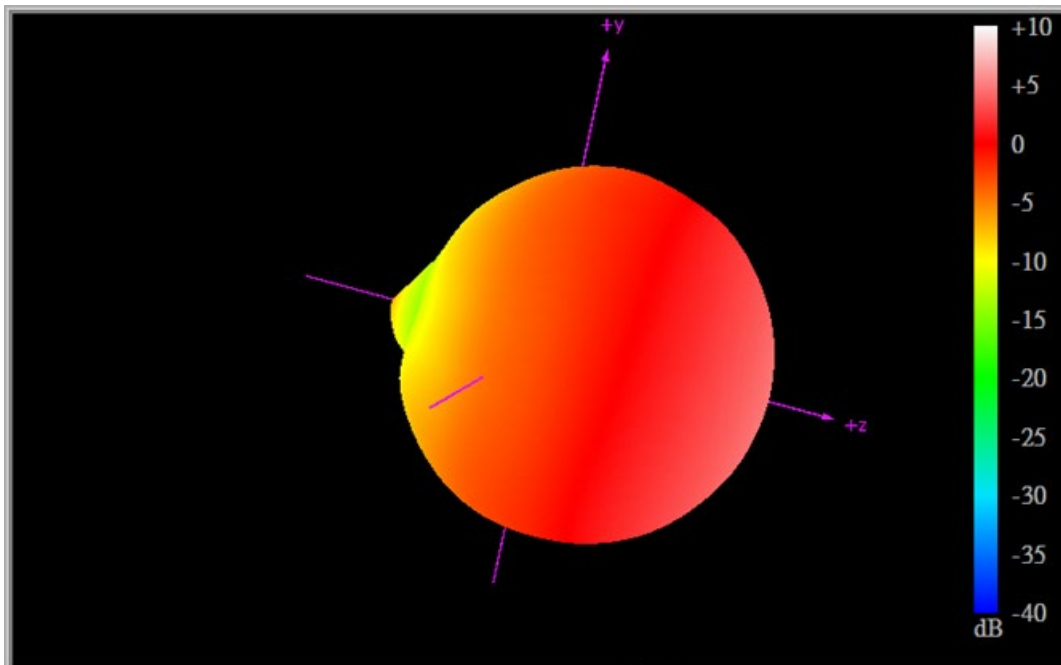

## 6. Mechanical Drawing-Patch (Units: mm)

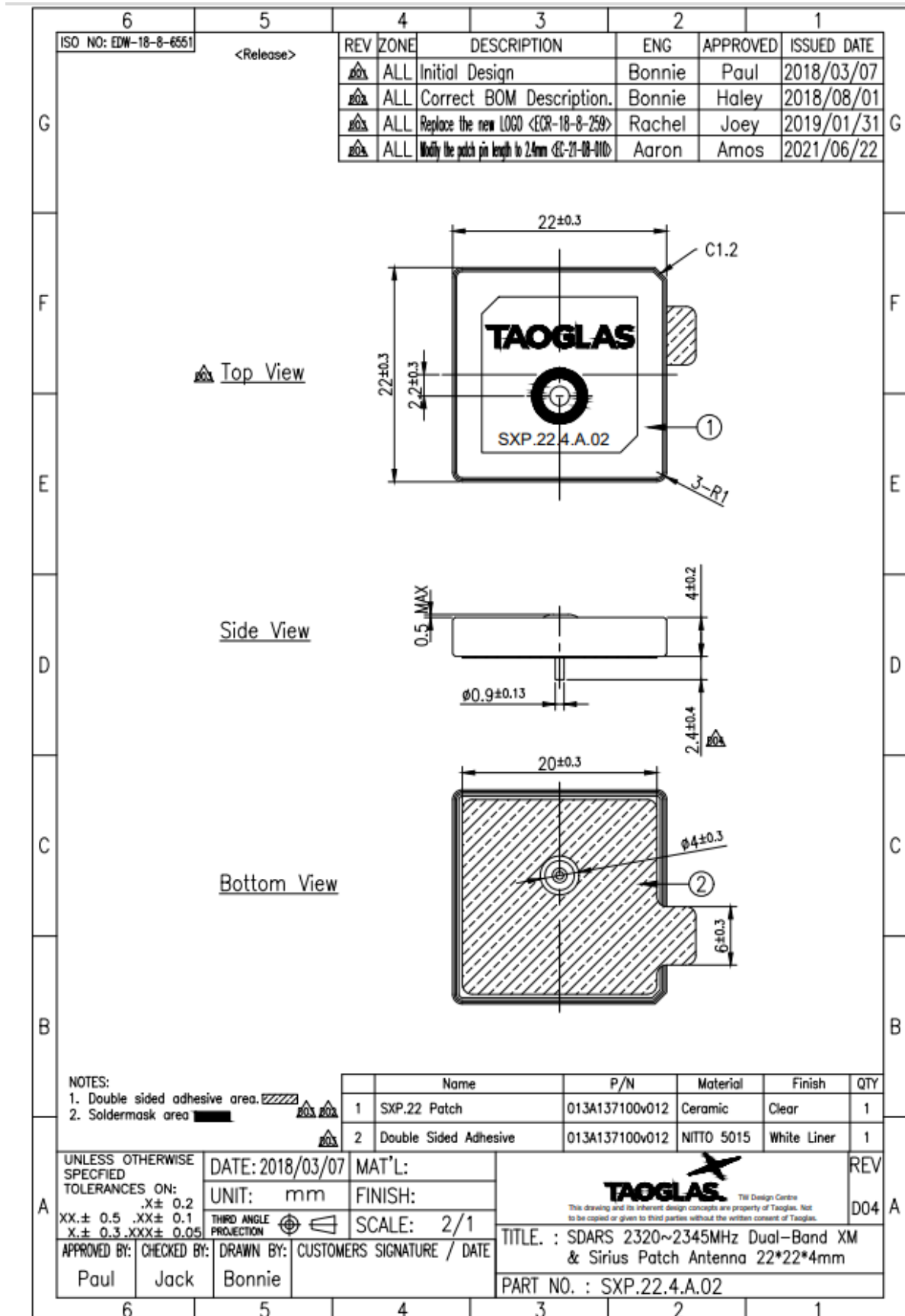

## 7. PCB Footprint Recommendation

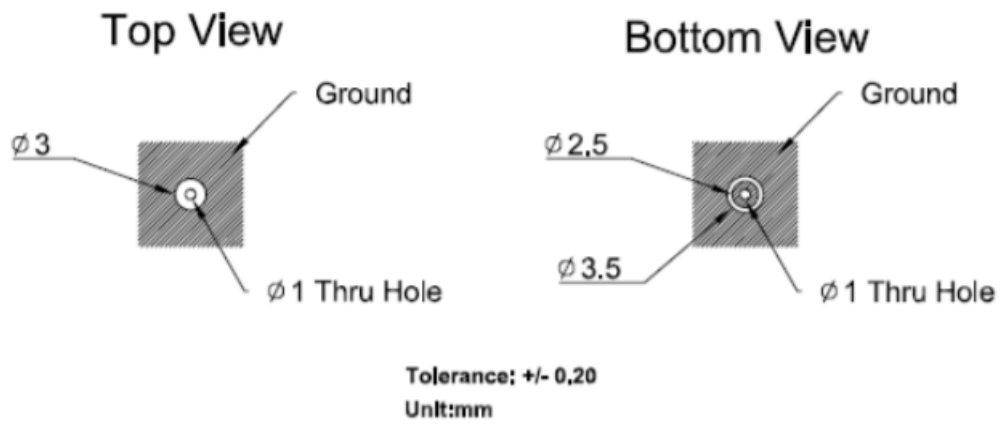

## 8. Packaging

50pc SXP.22.4.A.08 per Tray  
 Tray Dimensions - 260\*150\*30mm  
 Weight - 320g

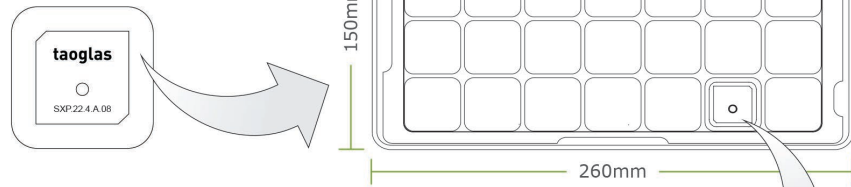

200pc SXP.22.4.A.08 per Box  
 Box Dimensions - 261\*152\*118mm  
 Weight - 1.45Kg

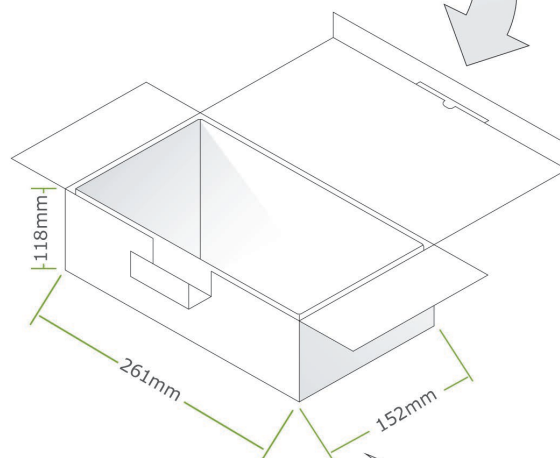

800pc SXP.22.4.A.08 per Box  
 Box Dimensions - 330\*280\*270mm  
 Weight - 6.2Kg

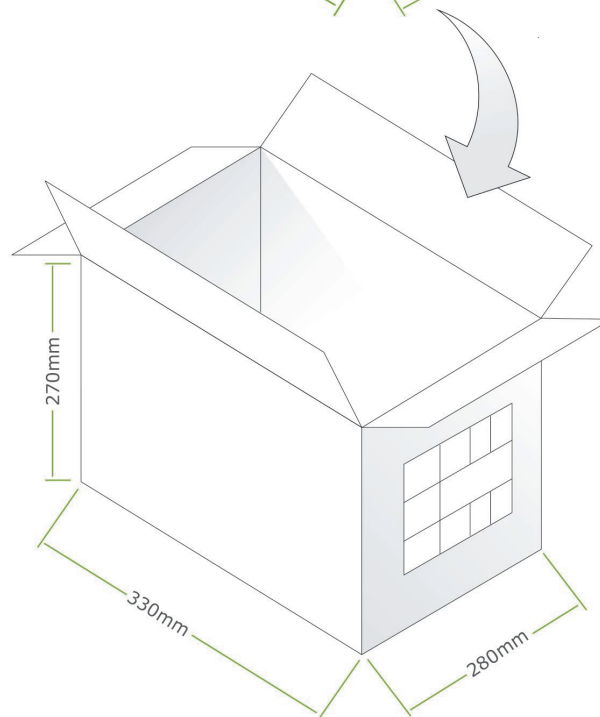



**TAOGLAS**®

[www.taoglas.com](http://www.taoglas.com)



## Looking for pricing, stock, or lifecycle information?

Click below to explore more details on WIN SOURCE:

- ⊖ [View SXP.22.4.A.02 on WIN SOURCE](#)
- ⊖ [Taoglas Limited Information](#)

## Optimize Your Supply Chain with WIN SOURCE Solutions

- ✓ Global Sourcing Solution
- ✓ Obsolete Management
- ✓ Cost Control Management
- ✓ Shortage Management
- ✓ Alternative Solution
- ✓ Excess Inventory Management