



**THE DATASHEET OF
SA615DK/01,112**



SA615

High performance low power mixer FM IF system

Rev. 4 — 14 November 2014

Product data sheet

1. General description

The SA615 is a high performance monolithic low-power FM IF system incorporating a mixer/oscillator, two limiting intermediate frequency amplifiers, quadrature detector, muting, logarithmic Received Signal Strength Indicator (RSSI), and voltage regulator. The SA615 combines the functions of NXP Semiconductors SA602A and SA604A, but features a higher mixer input intercept point, higher IF bandwidth (25 MHz) and temperature compensated RSSI and limiters permitting higher performance application. The SA615 is available in 20-lead SO (surface-mounted miniature package) and 20-lead SSOP (shrink small outline package).

The SA605 and SA615 are functionally the same device types. The difference between the two devices lies in the guaranteed specifications. The SA615 has a higher I_{CC} , lower input third-order intercept point, lower conversion mixer gain, lower limiter gain, lower AM rejection, lower SINAD, higher THD, and higher RSSI error than the SA605. Both the SA605 and SA615 devices meet the EIA specifications for AMPS and TACS cellular radio applications.

2. Features and benefits

- Low power consumption: 5.7 mA typical at 6 V
- Mixer input to >500 MHz
- Mixer conversion power gain of 13 dB at 45 MHz
- Mixer noise figure of 4.6 dB at 45 MHz
- XTAL oscillator effective to 150 MHz (L/C oscillator to 1 GHz local oscillator can be injected)
- 102 dB of IF amplifier/limiter gain
- 25 MHz limiter small signal bandwidth
- Temperature-compensated logarithmic Received Signal Strength Indicator (RSSI) with a dynamic range in excess of 90 dB
- Two audio outputs — muted and unmuted
- Low external component count; suitable for crystal/ceramic/LC filters
- Excellent sensitivity: 0.22 μ V into 50 Ω matching network for 12 dB SINAD (Signal-to-Noise-and-Distortion ratio) for 1 kHz tone with RF at 45 MHz and IF at 455 kHz
- SA615 meets cellular radio specifications
- ESD hardened



3. Applications

- Cellular radio FM IF
- High performance communications receivers
- Single conversion VHF/UHF receivers
- SCA receivers
- RF level meter
- Spectrum analyzer
- Instrumentation
- FSK and ASK data receivers
- Log amps
- Wideband low current amplification

4. Ordering information

Table 1. Ordering information

Type number	Topside marking	Package		
		Name	Description	Version
SA615D/01	SA615D	SO20	plastic small outline package; 20 leads; body width 7.5 mm	SOT163-1
SA615DK/01	SA615DK	SSOP20	plastic shrink small outline package; 20 leads; body width 4.4 mm	SOT266-1

4.1 Ordering options

Table 2. Ordering options

Type number	Orderable part number	Package	Packing method	Minimum order quantity	Temperature
SA615D/01	SA615D/01,112	SO20	Standard marking * IC's tube - DSC bulk pack	1520	T _{amb} = -40 °C to +85 °C
	SA615D/01,118	SO20	Reel 13" Q1/T1 *Standard mark SMD	2000	T _{amb} = -40 °C to +85 °C
SA615DK/01	SA615DK/01,112	SSOP20	Standard marking * IC's tube - DSC bulk pack	1350	T _{amb} = -40 °C to +85 °C
	SA615DK/01,118	SSOP20	Reel 13" Q1/T1 *Standard mark SMD	2500	T _{amb} = -40 °C to +85 °C

5. Block diagram

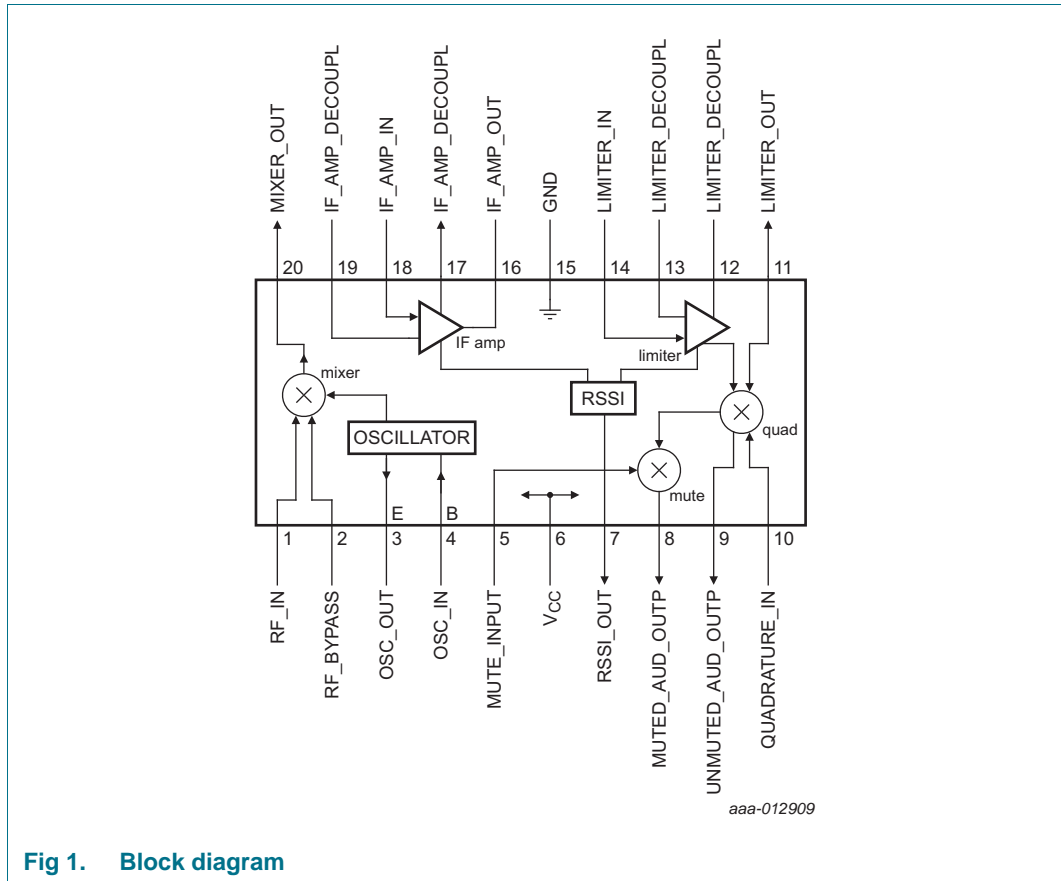

Fig 1. Block diagram

6. Pinning information

6.1 Pinning

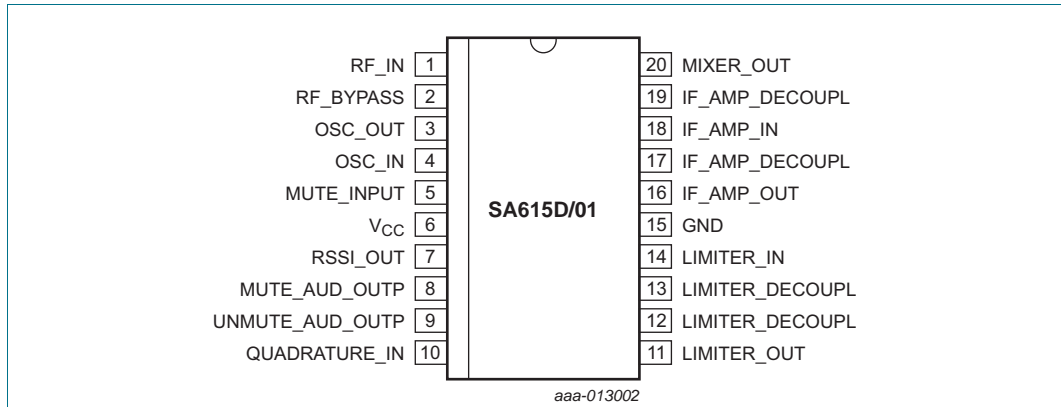

Fig 2. Pin configuration for SO20

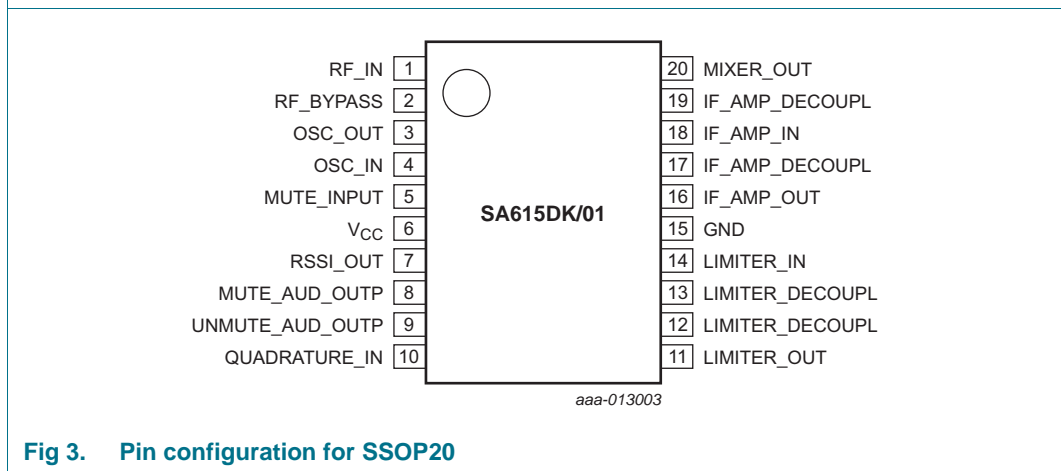

Fig 3. Pin configuration for SSOP20

6.2 Pin description

Table 3. Pin description

Symbol	Pin	Description
RF_IN	1	RF input
RF_BYPASS	2	RF bypass pin
OSC_OUT	3	oscillator output
OSC_IN	4	oscillator input
MUTE_INPUT	5	mute input
V _{CC}	6	positive supply voltage
RSSI_OUT	7	RSSI output
MUTED_AUD_OUTP	8	mute audio output
UNMUTED_AUD_OUTP	9	unmute audio output
QUADRATURE_IN	10	quadrature detector input terminal
LIMITER_OUT	11	limiter amplifier output
LIMITER_DECOUPL	12	limiter amplifier decoupling pin
LIMITER_DECOUPL	13	limiter amplifier decoupling pin
LIMITER_IN	14	limiter amplifier input
GND	15	ground; negative supply
IF_AMP_OUT	16	IF amplifier output
IF_AMP_DECOUPL	17	IF amplifier decoupling pin
IF_AMP_IN	18	IF amplifier input
IF_AMP_DECOUPL	19	IF amplifier decoupling pin
MIXER_OUT	20	mixer output

7. Limiting values

Table 4. Limiting values

In accordance with the Absolute Maximum Rating System (IEC 60134).

Symbol	Parameter	Conditions	Min	Max	Unit
V _{CC}	supply voltage		-	9	V
T _{stg}	storage temperature		-65	+150	°C
T _{amb}	ambient temperature	operating	-40	+85	°C

8. Thermal characteristics

Table 5. Thermal characteristics

Symbol	Parameter	Conditions	Typ	Unit
Z _{th(j-a)}	transient thermal impedance from junction to ambient	SA615D/01 (SO20)	90	K/W
		SA615DK/01 (SSOP20)	117	K/W

9. Static characteristics

Table 6. Static characteristics

V_{CC} = +6 V; T_{amb} = 25 °C; unless specified otherwise.

Symbol	Parameter	Conditions	Min	Typ	Max	Unit
V _{CC}	supply voltage		4.5	-	8.0	V
I _{CC}	supply current		-	5.7	7.4	mA
V _{th}	threshold voltage	mute switch-on	1.7	-	-	V
		mute switch-off	-	-	1.0	V

10. Dynamic characteristics

Table 7. Dynamic characteristics

$T_{amb} = 25\text{ °C}$; $V_{CC} = +6\text{ V}$; unless specified otherwise. RF frequency = 45 MHz + 14.5 dBV RF input step-up. IF frequency = 455 kHz; $R_{17} = 5.1\text{ k}\Omega$; RF level = -45 dBm; FM modulation = 1 kHz with $\pm 8\text{ kHz}$ peak deviation. Audio output with C-message weighted filter and de-emphasis capacitor. Test circuit [Figure 7](#). The parameters listed below are tested using automatic test equipment to assure consistent electrical characteristics. The limits do not represent the ultimate performance limits of the device. Use of an optimized RF layout improves many of the listed parameters.

Symbol	Parameter	Conditions	Min	Typ	Max	Unit
Mixer/oscillator section (external LO = 300 mV)						
f_i	input frequency		-	500	-	MHz
f_{osc}	oscillator frequency		-	150	-	MHz
NF	noise figure	at 45 MHz	-	5.0	-	dB
IP3 _i	input third-order intercept point	FL1 = 45.0 MHz; FL2 = 45.06 MHz	-	-12	-	dBm
$G_{p(conv)}$	conversion power gain	matched 14.5 dBV step-up	8.0	13	-	dB
		50 Ω source	-	-1.7	-	dB
$R_{i(RF)}$	RF input resistance	single-ended input	3.0	4.7	-	k Ω
$C_{i(RF)}$	RF input capacitance		-	3.5	4.0	pF
$R_{o(mix)}$	mixer output resistance	MIXER_OUT pin	1.25	1.50	-	k Ω
IF section						
$G_{amp(IF)}$	IF amplifier gain	50 Ω source	-	39.7	-	dB
G_{lim}	limiter gain	50 Ω source	-	62.5	-	dB
$P_{i(IF)}$	IF input power	for -3 dB input limiting sensitivity; $R_{17} = 5.1\text{ k}\Omega$; test at IF_AMP_IN pin	-	-109	-	dBm
α_{AM}	AM rejection	80 % AM 1 kHz	25	33	43	dB
	audio level	RMS value; $R_{10} = 100\text{ k}\Omega$; 15 nF de-emphasis	60	150	260	mV
	unmuted audio level	$R_{11} = 100\text{ k}\Omega$; 150 pF de-emphasis	-	530	-	mV
SINAD	signal-to-noise-and-distortion ratio	RF level -118 dB	-	12	-	dB
THD	total harmonic distortion		-30	-42	-	dB
S/N	signal-to-noise ratio	no modulation for noise	-	68	-	dB
$V_{o(RSSI)}$	RSSI output voltage	IF; $R_9 = 100\text{ k}\Omega$ [1]				
		IF level = -118 dBm	0	160	800	mV
		IF level = -68 dBm	1.7	2.5	3.3	V
		IF level = -18 dBm	3.6	4.8	5.8	V
$\alpha_{RSSI(range)}$	RSSI range	$R_9 = 100\text{ k}\Omega$; IF_AMP_OUT pin	-	80	-	dB
$\Delta\alpha_{RSSI}$	RSSI variation	$R_9 = 100\text{ k}\Omega$; IF_AMP_OUT pin	-	± 2	-	dB
$Z_{i(IF)}$	IF input impedance		1.40	1.6	-	k Ω
$Z_{o(IF)}$	IF output impedance		0.85	1.0	-	k Ω
$Z_{i(lim)}$	limiter input impedance		1.40	1.6	-	k Ω
R_o	output resistance	unmuted audio	-	58	-	k Ω
		muted audio	-	58	-	k Ω

Table 7. Dynamic characteristics ...continued

$T_{amb} = 25\text{ }^{\circ}\text{C}$; $V_{CC} = +6\text{ V}$; unless specified otherwise. RF frequency = 45 MHz + 14.5 dBV RF input step-up. IF frequency = 455 kHz; $R_{17} = 5.1\text{ k}\Omega$; RF level = -45 dBm; FM modulation = 1 kHz with $\pm 8\text{ kHz}$ peak deviation. Audio output with C-message weighted filter and de-emphasis capacitor. Test circuit [Figure 7](#). The parameters listed below are tested using automatic test equipment to assure consistent electrical characteristics. The limits do not represent the ultimate performance limits of the device. Use of an optimized RF layout improves many of the listed parameters.

Symbol	Parameter	Conditions	Min	Typ	Max	Unit
RF/IF section (internal LO)						
	unmuted audio level	RMS value; $V_{CC} = 4.5\text{ V}$; RF level = -27 dBm	-	450	-	mV
$V_{o(RSSI)}$	RSSI output voltage	system; $V_{CC} = 4.5\text{ V}$; RF level = -27 dBm	-	4.3	-	V

- [1] The generator source impedance is $50\ \Omega$, but the SA615 input impedance at pin 18 (IF_AMP_IN) is $1500\ \Omega$. As a result, IF level refers to the actual signal that enters the SA615 input (pin 8, MUTED_AUD_OUTP) which is about 21 dB less than the 'available power' at the generator.

11. Application information

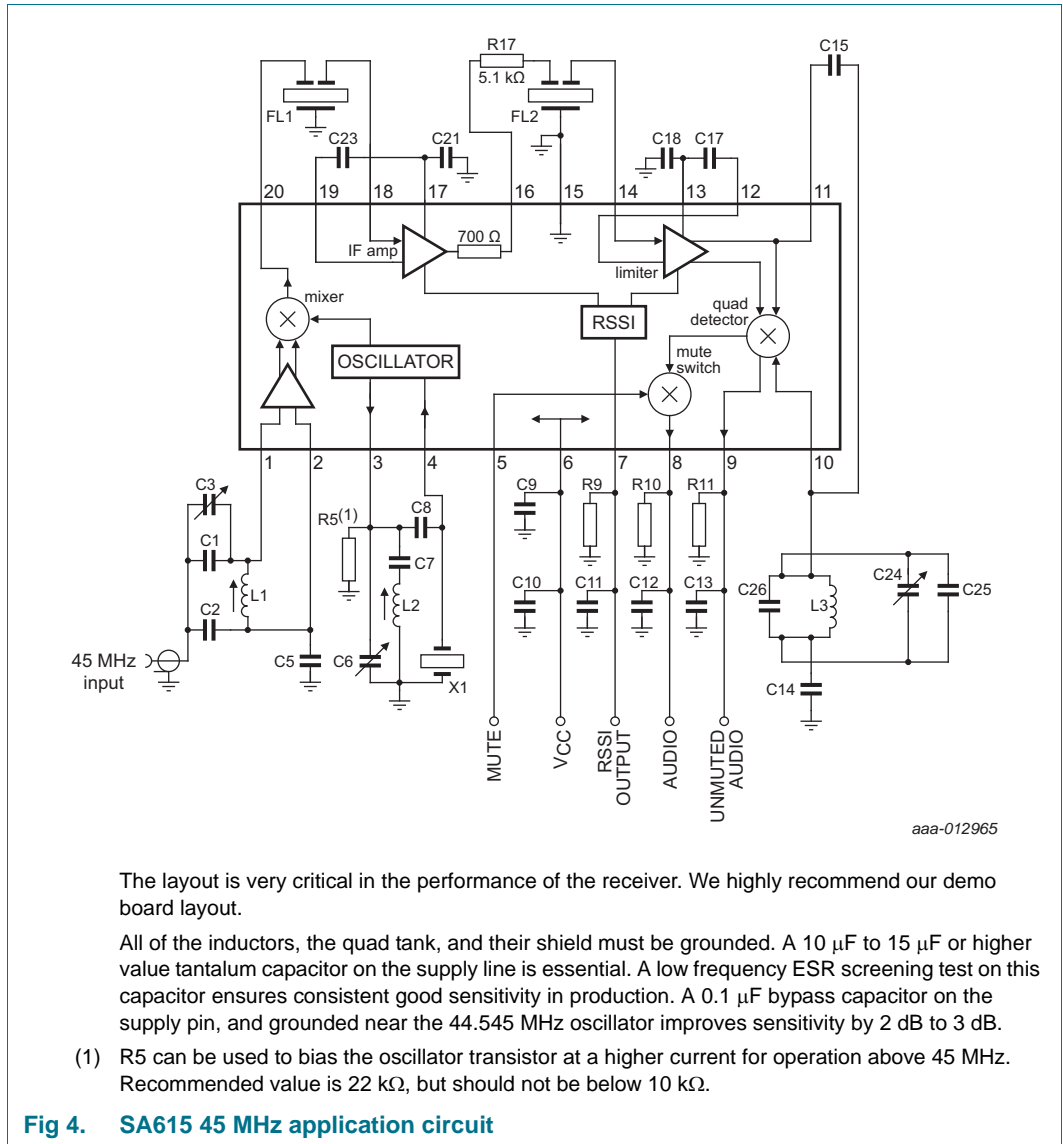

Table 8. SA615 application component list

Component	Value	Description	Package	Part number
C1	33 pF	NPO ceramic	C0805K	445-127x-1-ND
C2	220 pF	NPO ceramic	C0805K	445-7484-6-ND
C3	5 pF to 30 pF	NPO ceramic; Murata TZC3P300A 110R00	TRIMCAP	490-1994-2-ND
C5	100 nF \pm 10 %	100 nF \pm 10 % monolithic ceramic	C0805K	311-1036-1-ND
C6	5 pF to 30 pF	NPO ceramic; Murata TZC3P300A 110R00	TRIMCAP	490-1994-2-ND
C7	1 nF	ceramic	C0805K	399-3293-1-ND
C8	10 pF	NPO ceramic	C0805K	490-1994-2-ND
C9	100 nF \pm 10 %	monolithic ceramic	C0805K	311-1036-1-ND
C10 ^[1]	22 μ F	tantalum	C1812	478-3117-1-ND
C11	100 nF \pm 10 %	monolithic ceramic	C0805K	311-1036-1-ND
C12	15 nF \pm 10 %	ceramic	C0805K	399-1161-1-ND
C13	150 pF \pm 2 %	N1500 ceramic	C0805K	399-1125-1-ND
C14	100 nF \pm 10 %	monolithic ceramic	C0805K	311-1036-1-ND
C15	10.0 pF	NPO ceramic	C0805K	311-1036-1-ND
C17	100 nF \pm 10 %	monolithic ceramic	C0805K	311-1036-1-ND
C18	100 nF \pm 10 %	monolithic ceramic	C0805K	311-1036-1-ND
C21	100 nF \pm 10 %	monolithic ceramic	C0805K	311-1036-1-ND
C23	100 nF \pm 10 %	monolithic ceramic	C0805K	311-1036-1-ND
C24	5 pF to 30 pF trim	NPO ceramic; Murata TZC3P300A 110R00	TRIMCAP	490-1994-2-ND
C25	470 pF	monolithic ceramic	C0805K	
C26	39 pF	monolithic ceramic	C0805K	
CN1		8-pin header	MA08-1	399-8083-10ND
CN2		BU-SMA-H	J502-ND-142-0701-881/886	520-142-0701-881
FL1, FL2 ^[2]		ceramic filter; Murata CFUKF455KB4X or equivalent	surface mount	CFUKF455KB4X-R0
L1	330 nH	Coilcraft 1008CS-331	WE-KI_1008_B	1008CS-331
L2	1.2 μ H	fixed inductor Coilcraft 1008CS-122XKLC	WE-KI_1008_B	1008CS-122
L3	220 μ H	fixed inductor	WE-GF_L	1812LS-224XJB
R9	100 k Ω \pm 1 %	1/4 W metal film	R0603	311-100KCRCT-ND
R10 ^[3]	100 k Ω \pm 1 %	1/4 W metal film	C0805K	311-100KCRCT-ND
R11 ^[3]	100 k Ω \pm 1 %	1/4 W metal film	C0805K	311-100KCRCT-ND
R17	5.1 k Ω \pm 5 %	1/4 W carbon composition	C0805K	311-5.10KCRDKR-ND
U1		SA605DK	TSSOP20	568-2087-5-nd
X1	44.545 MHz	resonant 3rd-overtone crystal	UM-1	49HC/11453

[1] This value can be reduced when a battery is the power source.

[2] The ceramic filters can be 30 kHz SFG455A3s made by Murata, which have 30 kHz IF bandwidth (they come in blue), or 16 kHz CFU455Ds, also made by Murata (they come in black). All of our specifications and testing are done with the more wideband filter.

[3] Optional.

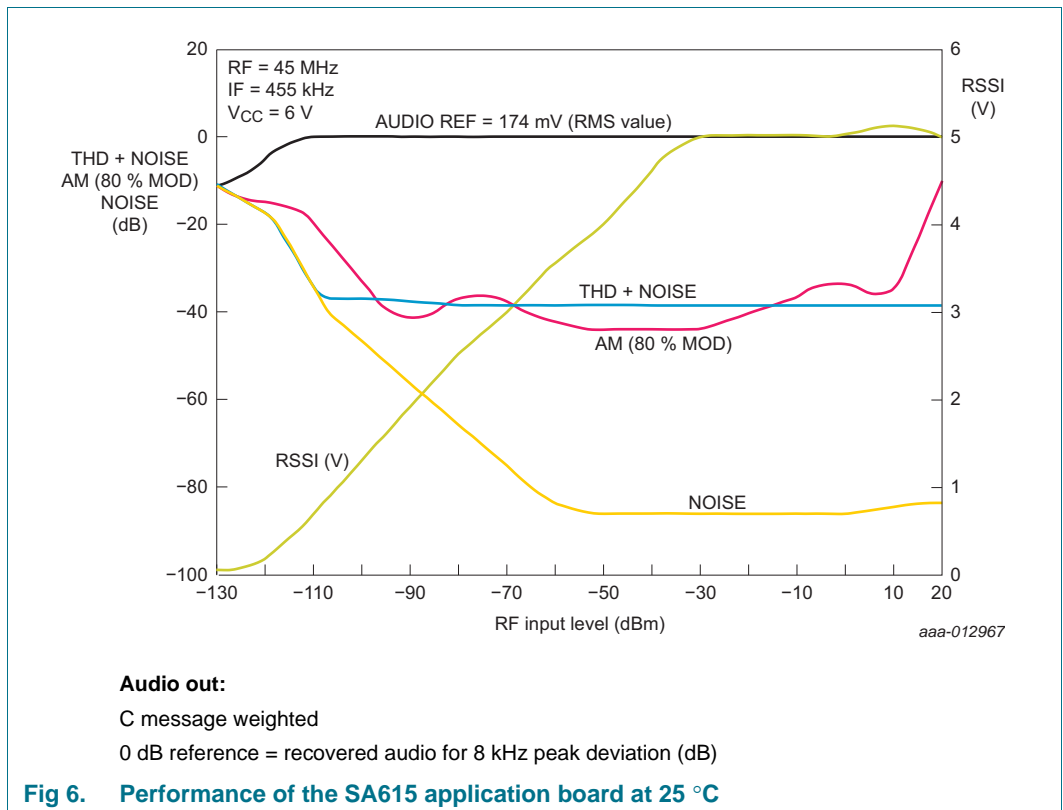
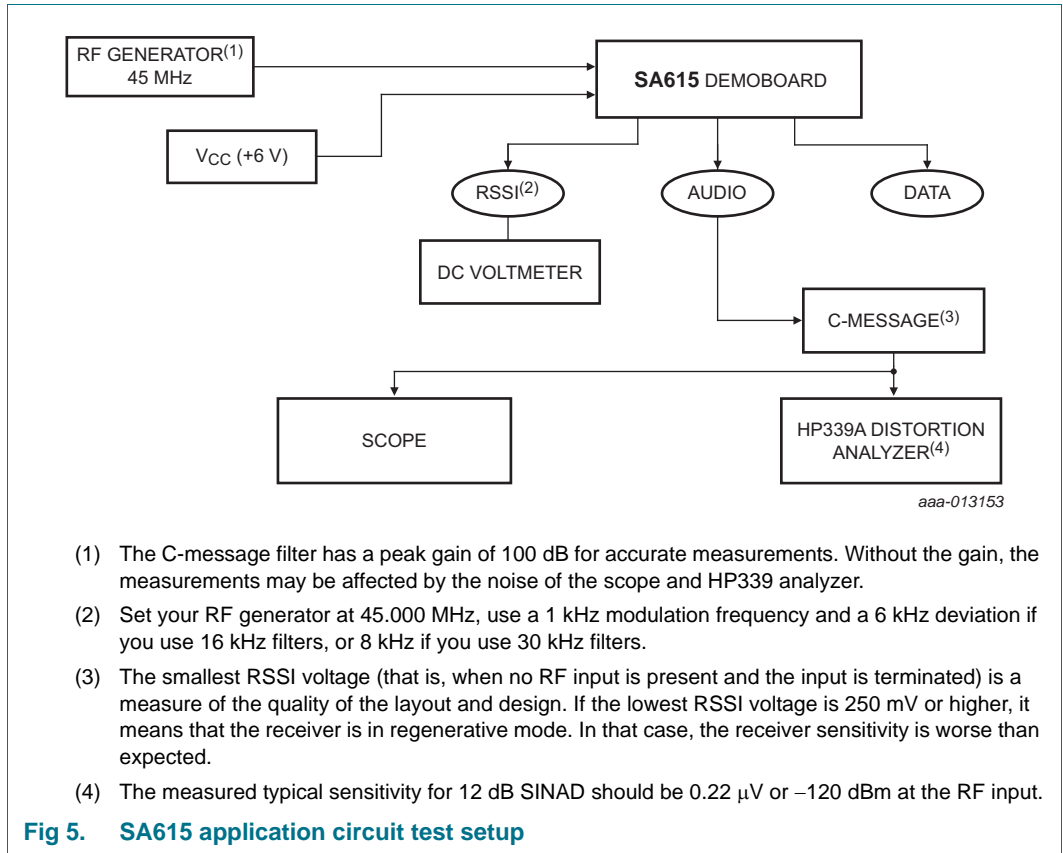

11.1 Circuit description

The SA615 is an IF signal processing system suitable for second IF or single conversion systems with input frequency as high as 1 GHz. The bandwidth of the IF amplifier is about 40 MHz, with 39.7 dB of gain from a 50 Ω source. The bandwidth of the limiter is about 28 MHz with about 62.5 dB of gain from a 50 Ω source. However, the gain/bandwidth distribution is optimized for 455 kHz, 1.5 k Ω source applications. The overall system is well-suited to battery operation as well as high-performance and high-quality products of all types.

The input stage is a Gilbert cell mixer with oscillator. Typical mixer characteristics include a noise figure of 5 dB, conversion gain of 13 dB, and input third-order intercept of -10 dBm. The oscillator operates in excess of 1 GHz in L/C tank configurations. Hartley or Colpitts circuits can be used up to 100 MHz for crystal configurations. Butler oscillators are recommended for crystal configurations up to 150 MHz.

The output of the mixer is internally loaded with a 1.5 k Ω resistor, permitting direct connection to a 455 kHz ceramic filter. The input resistance of the limiting IF amplifiers is also 1.5 k Ω . With most 455 kHz ceramic filters and many crystal filters, no impedance matching network is necessary. To achieve optimum linearity of the log signal strength indicator, there must be a 12 dBV insertion loss between the first and second IF stages. If the IF filter or inter-stage network does not cause 12 dBV insertion loss, a fixed or variable resistor can be added between the first IF output (pin 16, IF_AMP_OUT) and the inter-stage network.

The signal from the second limiting amplifier goes to a Gilbert cell quadrature detector. One port of the Gilbert cell is internally driven by the IF. The other output of the IF is AC-coupled to a tuned quadrature network. This signal, which now has a 90° phase relationship to the internal signal, drives the other port of the multiplier cell.

Overall, the IF section has a gain of 90 dB. For operation at intermediate frequencies greater than 455 kHz, special care must be given to layout, termination, and inter-stage loss to avoid instability.

The demodulated output of the quadrature detector is available at two pins, one continuous and one with a mute switch. Signal attenuation with the mute activated is greater than 60 dB. The mute input is very high-impedance and is compatible with CMOS or TTL levels.

A log signal strength completes the circuitry. The output range is greater than 90 dB and is temperature compensated. This log signal strength indicator exceeds the criteria for AMPS or TACS cellular telephone.

Remark: $\text{dBV} = 20\log V_O / V_I$.

Table 9. Automatic test circuit component list

Component	Description
C1	33 pF NPO ceramic
C2	180 pF NPO ceramic
C3, C6	5 pF to 30 pF variable capacitor; Murata TZC3P300A 110R00
C5, C9, C11, C14, C17, C18, C21, C23	100 nF \pm 10 % monolithic ceramic
C7	1 nF ceramic
C8, C15	10 pF NPO ceramic
C10 ^[1]	6.8 μ F tantalum (minimum)
C12	15 nF \pm 10 % ceramic
C13	150 pF \pm 2 % N1500 ceramic
C26	390 pF \pm 10 % monolithic ceramic
FL1	ceramic filter Murata SFG455A3 or equivalent
FL2	
IFT1	330 μ H variable shielded inductor, Toko 836AN-0129Z
L1	330 nH Coilcraft 1008CS-331
L2	1.2 μ H Coilcraft 1008CS-122
X1	44.545 MHz 3rd Overtone series resonant crystal in the HC-49U case
R9	100 k Ω \pm 1 % 1/4 W metal film
R10, R11	100 k Ω \pm 1 % 1/4 W metal film (optional)
R17	5.1 k Ω \pm 5 % 1/4 W carbon composition

[1] This value can be reduced when a battery is the power source.

13. Package outline

SO20: plastic small outline package; 20 leads; body width 7.5 mm

SOT163-1

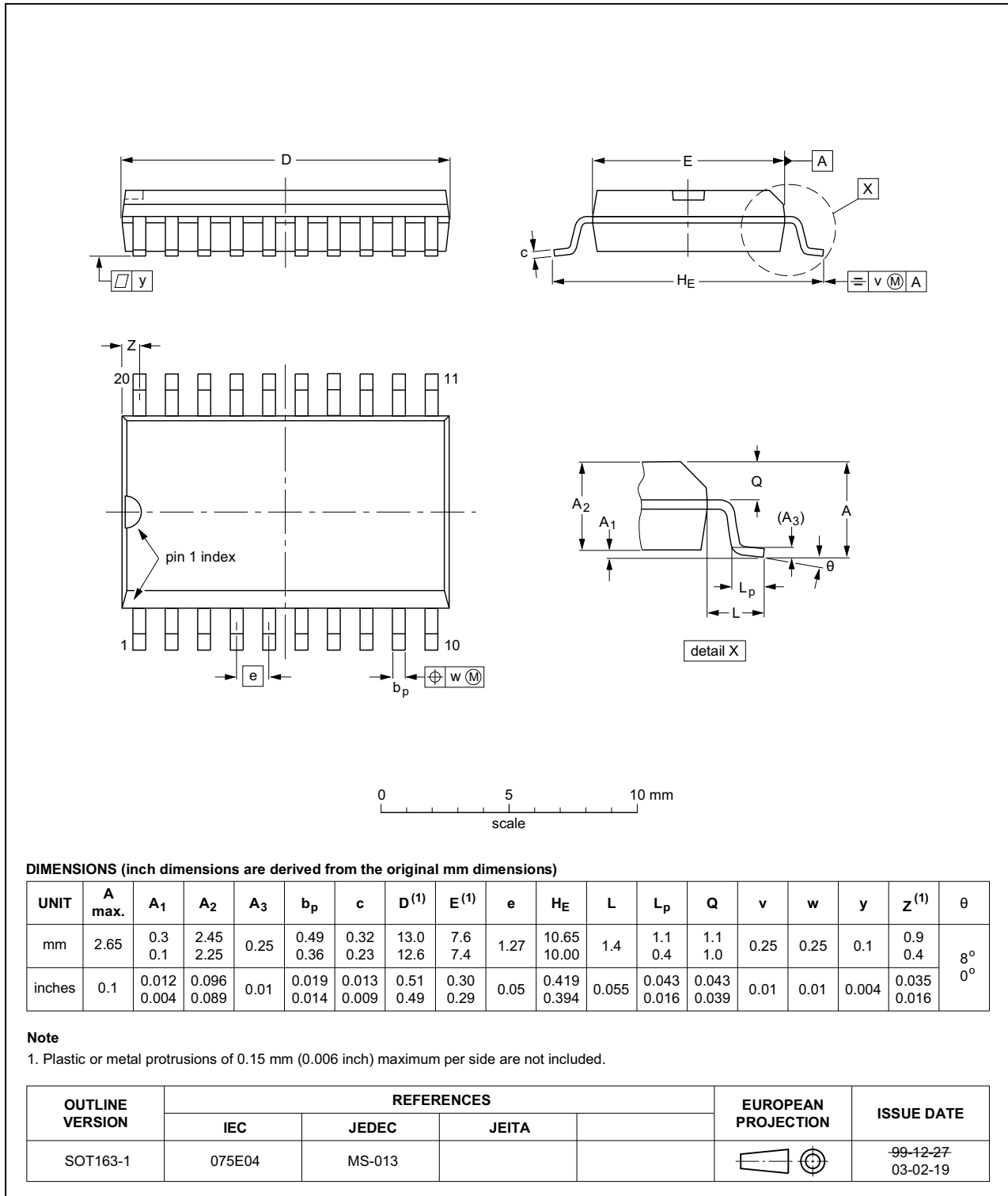

Fig 8. Package outline SOT163-1 (SO20)

SSOP20: plastic shrink small outline package; 20 leads; body width 4.4 mm

SOT266-1

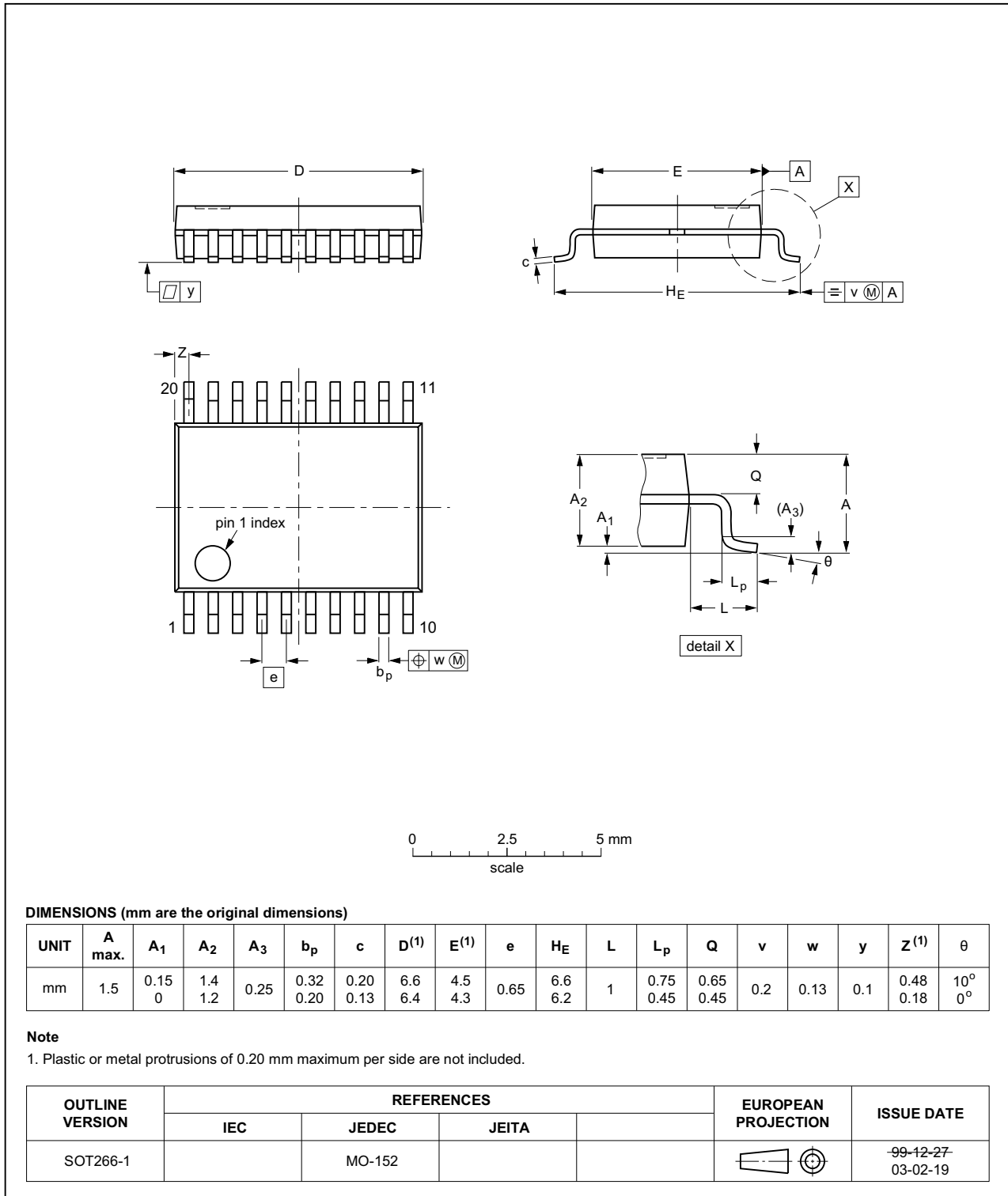

Fig 9. Package outline SOT266-1 (SSOP20)

14. Soldering of SMD packages

This text provides a very brief insight into a complex technology. A more in-depth account of soldering ICs can be found in Application Note *AN10365 "Surface mount reflow soldering description"*.

14.1 Introduction to soldering

Soldering is one of the most common methods through which packages are attached to Printed Circuit Boards (PCBs), to form electrical circuits. The soldered joint provides both the mechanical and the electrical connection. There is no single soldering method that is ideal for all IC packages. Wave soldering is often preferred when through-hole and Surface Mount Devices (SMDs) are mixed on one printed wiring board; however, it is not suitable for fine pitch SMDs. Reflow soldering is ideal for the small pitches and high densities that come with increased miniaturization.

14.2 Wave and reflow soldering

Wave soldering is a joining technology in which the joints are made by solder coming from a standing wave of liquid solder. The wave soldering process is suitable for the following:

- Through-hole components
- Leaded or leadless SMDs, which are glued to the surface of the printed circuit board

Not all SMDs can be wave soldered. Packages with solder balls, and some leadless packages which have solder lands underneath the body, cannot be wave soldered. Also, leaded SMDs with leads having a pitch smaller than ~0.6 mm cannot be wave soldered, due to an increased probability of bridging.

The reflow soldering process involves applying solder paste to a board, followed by component placement and exposure to a temperature profile. Leaded packages, packages with solder balls, and leadless packages are all reflow solderable.

Key characteristics in both wave and reflow soldering are:

- Board specifications, including the board finish, solder masks and vias
- Package footprints, including solder thieves and orientation
- The moisture sensitivity level of the packages
- Package placement
- Inspection and repair
- Lead-free soldering versus SnPb soldering

14.3 Wave soldering

Key characteristics in wave soldering are:

- Process issues, such as application of adhesive and flux, clinching of leads, board transport, the solder wave parameters, and the time during which components are exposed to the wave
- Solder bath specifications, including temperature and impurities

14.4 Reflow soldering

Key characteristics in reflow soldering are:

- Lead-free versus SnPb soldering; note that a lead-free reflow process usually leads to higher minimum peak temperatures (see [Figure 10](#)) than a SnPb process, thus reducing the process window
- Solder paste printing issues including smearing, release, and adjusting the process window for a mix of large and small components on one board
- Reflow temperature profile; this profile includes preheat, reflow (in which the board is heated to the peak temperature) and cooling down. It is imperative that the peak temperature is high enough for the solder to make reliable solder joints (a solder paste characteristic). In addition, the peak temperature must be low enough that the packages and/or boards are not damaged. The peak temperature of the package depends on package thickness and volume and is classified in accordance with [Table 10](#) and [11](#)

Table 10. SnPb eutectic process (from J-STD-020D)

Package thickness (mm)	Package reflow temperature (°C)	
	Volume (mm ³)	
	< 350	≥ 350
< 2.5	235	220
≥ 2.5	220	220

Table 11. Lead-free process (from J-STD-020D)

Package thickness (mm)	Package reflow temperature (°C)		
	Volume (mm ³)		
	< 350	350 to 2000	> 2000
< 1.6	260	260	260
1.6 to 2.5	260	250	245
> 2.5	250	245	245

Moisture sensitivity precautions, as indicated on the packing, must be respected at all times.

Studies have shown that small packages reach higher temperatures during reflow soldering, see [Figure 10](#).

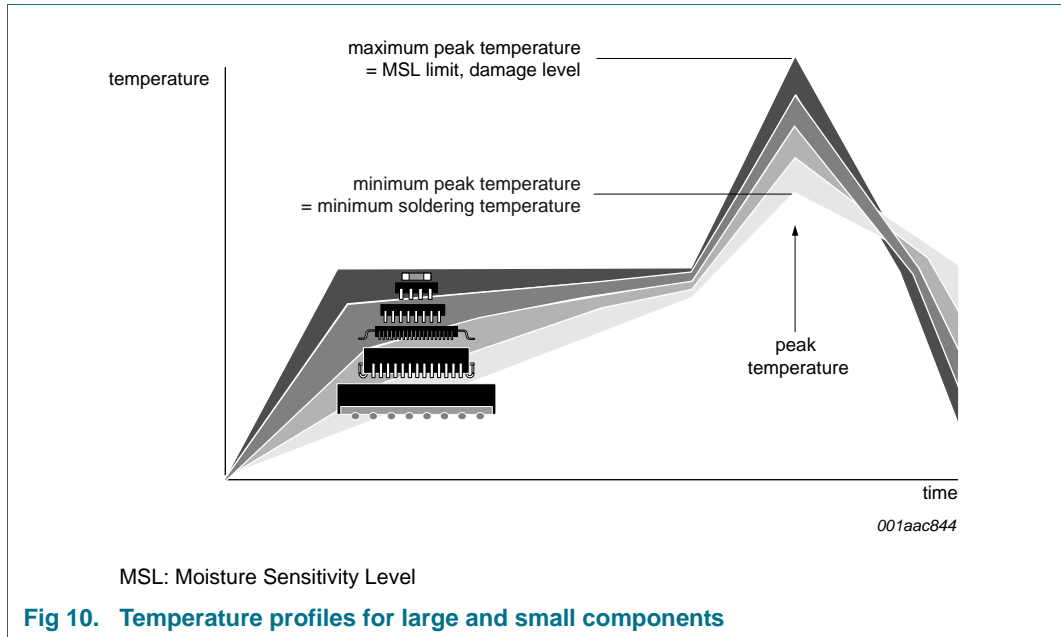

For further information on temperature profiles, refer to Application Note AN10365 “Surface mount reflow soldering description”.

15. Soldering: PCB footprints

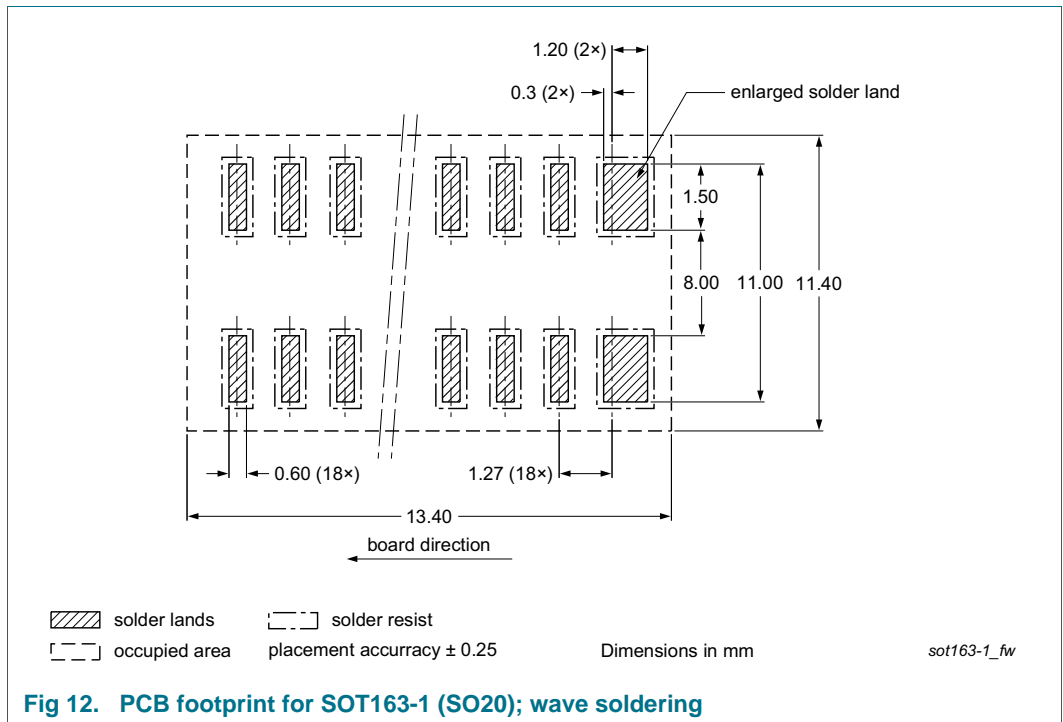
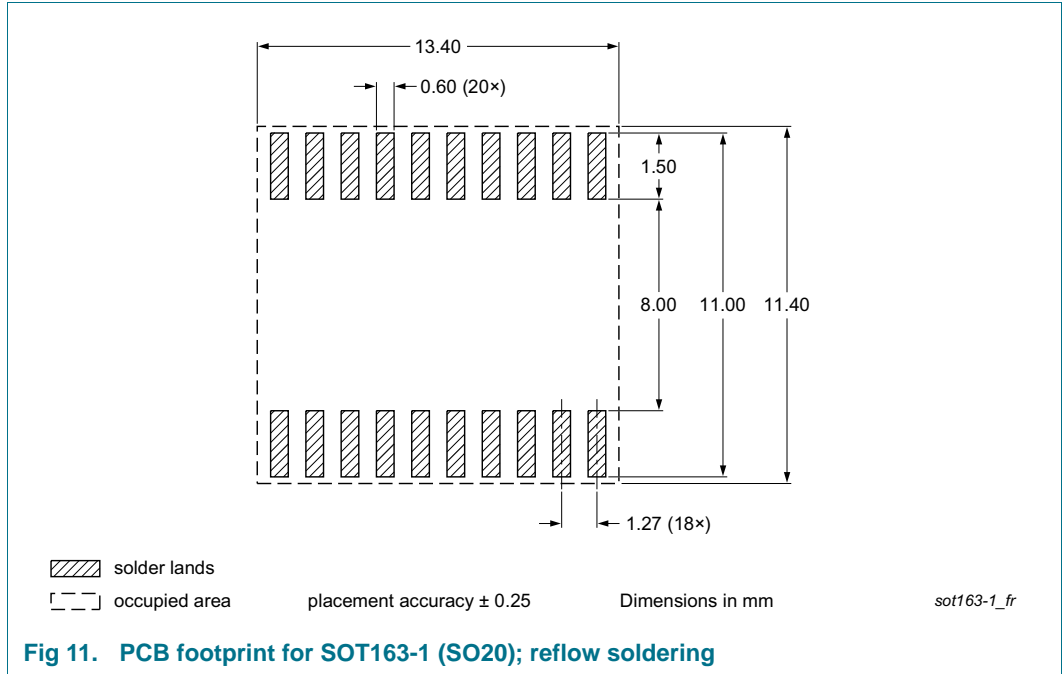

Footprint information for reflow soldering of SSOP20 package

SOT266-1

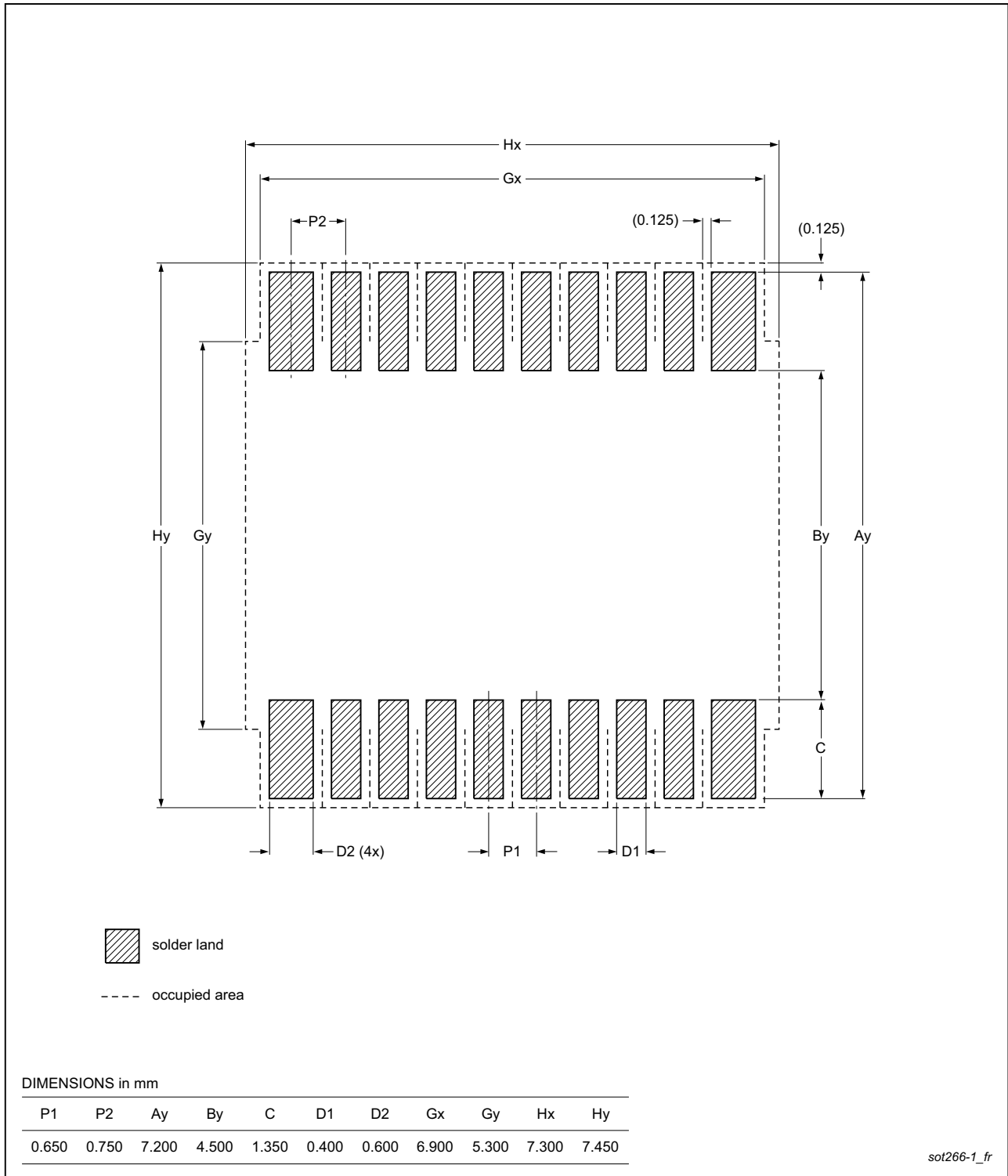

Fig 13. PCB footprint for SOT266-1 (SSOP20); reflow soldering

16. Abbreviations

Table 12. Abbreviations

Acronym	Description
AM	Amplitude Modulation
AMPS	Advanced Mobile Phone System
ASK	Amplitude Shift Keying
CMOS	Complementary Metal-Oxide Semiconductor
ESD	ElectroStatic Discharge
ESR	Equivalent Series Resistor
FM	Frequency Modulation
FSK	Frequency Shift Keying
IF	Intermediate Frequency
L/C	inductor-capacitor filter
RF	Radio Frequency
RSSI	Received Signal Strength Indicator
SCA	Subsidiary Communications Authorization
SINAD	Signal-to-Noise-And-Distortion ratio
TACS	Total Access Communication System
THD	Total Harmonic Distortion
TTL	Transistor-Transistor Logic
UHF	Ultra High Frequency
VHF	Very High Frequency

17. Revision history

Table 13. Revision history

Document ID	Release date	Data sheet status	Change notice	Supersedes
SA615 v.4	20141114	Product data sheet	-	SA615 v.3
Modifications:	<ul style="list-style-type: none">• Table 8 "SA615 application component list" updated• Figure 4 "SA615 45 MHz application circuit" updated			
SA615 v.3	20140512	Product data sheet	-	SA615 v.2
SA615 v.2	19971107	Product specification	853-1402 18665	NE/SA615 v.1
NE/SA615 v.1	19921103	Product specification	853-1402 08109	-

18. Legal information

18.1 Data sheet status

Document status ^{[1][2]}	Product status ^[3]	Definition
Objective [short] data sheet	Development	This document contains data from the objective specification for product development.
Preliminary [short] data sheet	Qualification	This document contains data from the preliminary specification.
Product [short] data sheet	Production	This document contains the product specification.

[1] Please consult the most recently issued document before initiating or completing a design.

[2] The term 'short data sheet' is explained in section "Definitions".

[3] The product status of device(s) described in this document may have changed since this document was published and may differ in case of multiple devices. The latest product status information is available on the Internet at URL <http://www.nxp.com>.

18.2 Definitions

Draft — The document is a draft version only. The content is still under internal review and subject to formal approval, which may result in modifications or additions. NXP Semiconductors does not give any representations or warranties as to the accuracy or completeness of information included herein and shall have no liability for the consequences of use of such information.

Short data sheet — A short data sheet is an extract from a full data sheet with the same product type number(s) and title. A short data sheet is intended for quick reference only and should not be relied upon to contain detailed and full information. For detailed and full information see the relevant full data sheet, which is available on request via the local NXP Semiconductors sales office. In case of any inconsistency or conflict with the short data sheet, the full data sheet shall prevail.

Product specification — The information and data provided in a Product data sheet shall define the specification of the product as agreed between NXP Semiconductors and its customer, unless NXP Semiconductors and customer have explicitly agreed otherwise in writing. In no event however, shall an agreement be valid in which the NXP Semiconductors product is deemed to offer functions and qualities beyond those described in the Product data sheet.

18.3 Disclaimers

Limited warranty and liability — Information in this document is believed to be accurate and reliable. However, NXP Semiconductors does not give any representations or warranties, expressed or implied, as to the accuracy or completeness of such information and shall have no liability for the consequences of use of such information. NXP Semiconductors takes no responsibility for the content in this document if provided by an information source outside of NXP Semiconductors.

In no event shall NXP Semiconductors be liable for any indirect, incidental, punitive, special or consequential damages (including - without limitation - lost profits, lost savings, business interruption, costs related to the removal or replacement of any products or rework charges) whether or not such damages are based on tort (including negligence), warranty, breach of contract or any other legal theory.

Notwithstanding any damages that customer might incur for any reason whatsoever, NXP Semiconductors' aggregate and cumulative liability towards customer for the products described herein shall be limited in accordance with the *Terms and conditions of commercial sale* of NXP Semiconductors.

Right to make changes — NXP Semiconductors reserves the right to make changes to information published in this document, including without limitation specifications and product descriptions, at any time and without notice. This document supersedes and replaces all information supplied prior to the publication hereof.

Suitability for use — NXP Semiconductors products are not designed, authorized or warranted to be suitable for use in life support, life-critical or safety-critical systems or equipment, nor in applications where failure or malfunction of an NXP Semiconductors product can reasonably be expected to result in personal injury, death or severe property or environmental damage. NXP Semiconductors and its suppliers accept no liability for inclusion and/or use of NXP Semiconductors products in such equipment or applications and therefore such inclusion and/or use is at the customer's own risk.

Applications — Applications that are described herein for any of these products are for illustrative purposes only. NXP Semiconductors makes no representation or warranty that such applications will be suitable for the specified use without further testing or modification.

Customers are responsible for the design and operation of their applications and products using NXP Semiconductors products, and NXP Semiconductors accepts no liability for any assistance with applications or customer product design. It is customer's sole responsibility to determine whether the NXP Semiconductors product is suitable and fit for the customer's applications and products planned, as well as for the planned application and use of customer's third party customer(s). Customers should provide appropriate design and operating safeguards to minimize the risks associated with their applications and products.

NXP Semiconductors does not accept any liability related to any default, damage, costs or problem which is based on any weakness or default in the customer's applications or products, or the application or use by customer's third party customer(s). Customer is responsible for doing all necessary testing for the customer's applications and products using NXP Semiconductors products in order to avoid a default of the applications and the products or of the application or use by customer's third party customer(s). NXP does not accept any liability in this respect.

Limiting values — Stress above one or more limiting values (as defined in the Absolute Maximum Ratings System of IEC 60134) will cause permanent damage to the device. Limiting values are stress ratings only and (proper) operation of the device at these or any other conditions above those given in the Recommended operating conditions section (if present) or the Characteristics sections of this document is not warranted. Constant or repeated exposure to limiting values will permanently and irreversibly affect the quality and reliability of the device.

Terms and conditions of commercial sale — NXP Semiconductors products are sold subject to the general terms and conditions of commercial sale, as published at <http://www.nxp.com/profile/terms>, unless otherwise agreed in a valid written individual agreement. In case an individual agreement is concluded only the terms and conditions of the respective agreement shall apply. NXP Semiconductors hereby expressly objects to applying the customer's general terms and conditions with regard to the purchase of NXP Semiconductors products by customer.

No offer to sell or license — Nothing in this document may be interpreted or construed as an offer to sell products that is open for acceptance or the grant, conveyance or implication of any license under any copyrights, patents or other industrial or intellectual property rights.

Export control — This document as well as the item(s) described herein may be subject to export control regulations. Export might require a prior authorization from competent authorities.

Non-automotive qualified products — Unless this data sheet expressly states that this specific NXP Semiconductors product is automotive qualified, the product is not suitable for automotive use. It is neither qualified nor tested in accordance with automotive testing or application requirements. NXP Semiconductors accepts no liability for inclusion and/or use of non-automotive qualified products in automotive equipment or applications.

In the event that customer uses the product for design-in and use in automotive applications to automotive specifications and standards, customer (a) shall use the product without NXP Semiconductors' warranty of the product for such automotive applications, use and specifications, and (b) whenever customer uses the product for automotive applications beyond

NXP Semiconductors' specifications such use shall be solely at customer's own risk, and (c) customer fully indemnifies NXP Semiconductors for any liability, damages or failed product claims resulting from customer design and use of the product for automotive applications beyond NXP Semiconductors' standard warranty and NXP Semiconductors' product specifications.

Translations — A non-English (translated) version of a document is for reference only. The English version shall prevail in case of any discrepancy between the translated and English versions.

18.4 Trademarks

Notice: All referenced brands, product names, service names and trademarks are the property of their respective owners.

19. Contact information

For more information, please visit: <http://www.nxp.com>

For sales office addresses, please send an email to: salesaddresses@nxp.com

20. Contents

1	General description	1
2	Features and benefits	1
3	Applications	2
4	Ordering information	2
4.1	Ordering options	2
5	Block diagram	3
6	Pinning information	4
6.1	Pinning	4
6.2	Pin description	5
7	Limiting values	6
8	Thermal characteristics	6
9	Static characteristics	6
10	Dynamic characteristics	7
11	Application information	9
11.1	Circuit description	12
12	Test information	13
13	Package outline	15
14	Soldering of SMD packages	17
14.1	Introduction to soldering	17
14.2	Wave and reflow soldering	17
14.3	Wave soldering	17
14.4	Reflow soldering	18
15	Soldering: PCB footprints	20
16	Abbreviations	22
17	Revision history	23
18	Legal information	24
18.1	Data sheet status	24
18.2	Definitions	24
18.3	Disclaimers	24
18.4	Trademarks	25
19	Contact information	25
20	Contents	26

Please be aware that important notices concerning this document and the product(s) described herein, have been included in section 'Legal information'.

© NXP Semiconductors N.V. 2014.

All rights reserved.

For more information, please visit: <http://www.nxp.com>

For sales office addresses, please send an email to: salesaddresses@nxp.com

Date of release: 14 November 2014

Document identifier: SA615

Looking for pricing, stock, or lifecycle information?

Click below to explore more details on WIN SOURCE:

- ⊖ [View SA615DK/01,112 on WIN SOURCE](#)
- ⊖ [NXP / Nexperia Information](#)

Optimize Your Supply Chain with WIN SOURCE Solutions

- ✓ Global Sourcing Solution
- ✓ Obsolete Management
- ✓ Cost Control Management
- ✓ Shortage Management
- ✓ Alternative Solution
- ✓ Excess Inventory Management