



**THE DATASHEET OF
SN761688PWRG4**



FEATURES

- RF AGC Amplifier, Mixer, and IF Amplifier Circuits
- Low Distortion
- 5-V Power Supply
- 16-Pin TSSOP Package

APPLICATION

- CATV

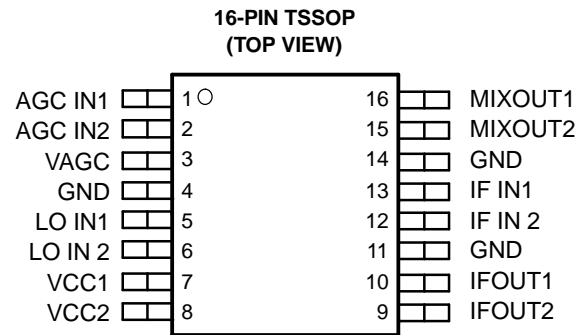

DESCRIPTION

The SN761688 is a monolithic IC designed as an out-of-band tuner for CATV. The circuit consists of an RF AGC amplifier, mixer, and IF amplifier, and is available in a small-outline package.

FUNCTIONAL BLOCK DIAGRAM

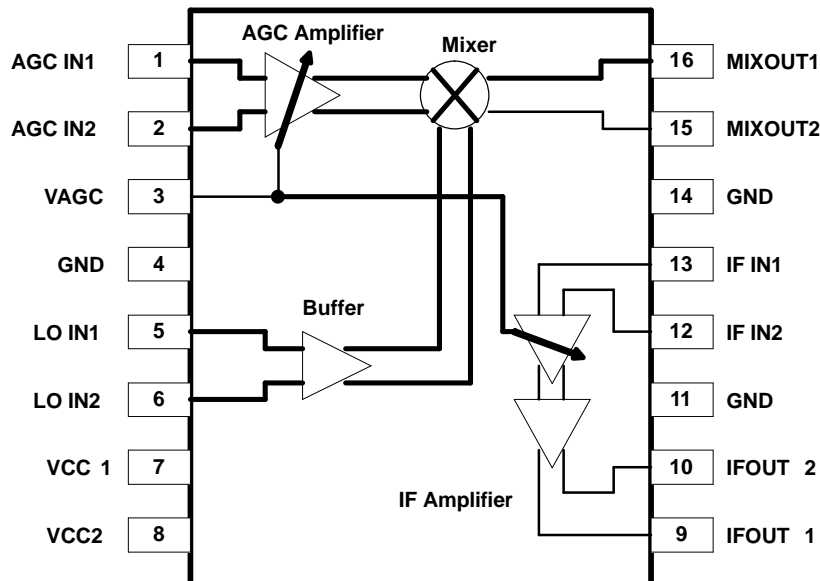

This integrated circuit can be damaged by ESD. Texas Instruments recommends that all integrated circuits be handled with appropriate precautions. Failure to observe proper handling and installation procedures can cause damage.



ESD damage can range from subtle performance degradation to complete device failure. Precision integrated circuits may be more susceptible to damage because very small parametric changes could cause the device not to meet its published specifications.



Please be aware that an important notice concerning availability, standard warranty, and use in critical applications of Texas Instruments semiconductor products and disclaimers thereto appears at the end of this data sheet.

TERMINAL FUNCTIONS

TERMINAL NAME NO.		DESCRIPTION	SCHEMATIC
AGC IN1	1	Input of AGC amplifier	Figure 1
AGC IN2	2		
VAGC	3	Input of gain control voltage	Figure 2
GND	4, 11, 14	Ground	
LO IN1	5	Input of local OSC	Figure 3
LO IN2	6		
VCC1	7	5 V power supply; AGC/Mixer/Buffer	
VCC2	8	5 V power supply; IF amplifier	
IF OUT1	9	Output of IF amplifier	Figure 4
IF OUT2	10		
IF IN2	12	Input of IF amplifier	Figure 5
IF IN1	13		
MIXOUT2	15	Output of Mixer	Figure 6
MIXOUT1	16		

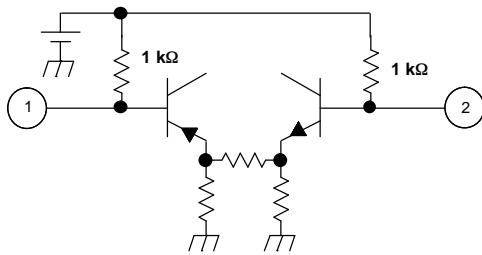

Figure 1.

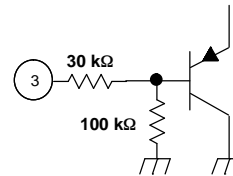

Figure 2.

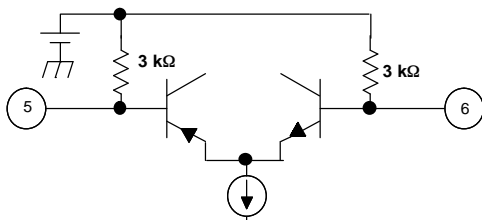

Figure 3.

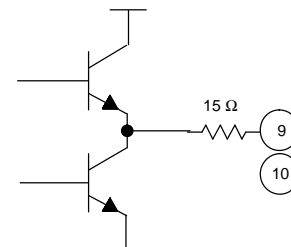

Figure 4.

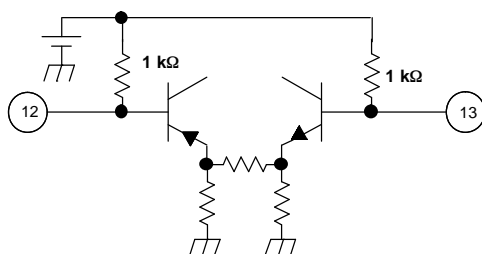

Figure 5.

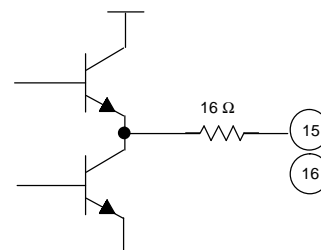

Figure 6.

ABSOLUTE MAXIMUM RATINGS

over operating free-air temperature range (unless otherwise noted) ⁽¹⁾

Supply voltage, V_{CC} ⁽²⁾	VCC1,2 (Pin 7, 8)	-0.4 V to 6.5 V
Input voltage ⁽²⁾	V_{IN} (Pins 1, 2, 3, 5, 6, 12, 13)	-0.4 V to V_{CC}
Continuous total dissipation, P_D ⁽³⁾	$T_A \leq 25^\circ\text{C}$	775 mW
Maximum junction temperature, T_J		150°C

- (1) Stresses beyond those listed under "absolute maximum ratings" may cause permanent damage to the device. These are stress ratings only, and functional operation of the device at these or any other conditions beyond those indicated under "recommended operating conditions" is not implied. Exposure to absolute-maximum-rated conditions for extended periods may affect device reliability.
- (2) Voltage values are with respect to the GND of the circuit.
- (3) Derating factor is 6.2 mW/°C for $T_A \geq 25^\circ\text{C}$.

RECOMMENDED OPERATING CONDITIONS

over operating free-air temperature range (unless otherwise noted)

	MIN	NOM	MAX	UNIT
Supply voltage, V_{CC}	4.5	5	5.5	V
Operating free-air temperature, T_A	-20		85	°C

DC ELECTRICAL CHARACTERISTICS

$V_{CC} = 5\text{ V}$, $T_A = 25^\circ\text{C}$, unless otherwise noted

PARAMETER	TEST CONDITIONS	MIN	TYP	MAX	UNIT
I_{CC} Supply current	No signal, $V_{AGC} = 0\text{ V}$		67		mA
I_{AGC} Input current (V_{AGC})	$V_{AGC} = 3\text{ V}$		22	33	μA
$V_{AGC\text{MAX}}$ AGC voltage high at maximum gain		3		V_{CC}	V
$V_{AGC\text{MIN}}$ AGC voltage low at minimum gain		0		0.5	V

AC ELECTRICAL CHARACTERISTICS

$V_{CC} = 5\text{ V}$, $T_A = 25^\circ\text{C}$, unless otherwise noted

PARAMETER	TEST CONDITIONS	MIN	TYP	MAX	UNIT
AGC amplifier and mixer ⁽¹⁾					
GC_{MAX} Maximum conversion gain	$V_{AGC} = 3\text{ V}$	27	30	33	dB
GC_{MIN} Minimum conversion gain	$V_{AGC} = 0\text{ V}$	-21	-18	-15	dB
GCR_{MIX} Gain control range	$V_{AGC} = 0\text{ V to } 3\text{ V}$		48		dB
V_{MIXOUT} Mixer output voltage	$V_{AGC} = 3\text{ V}$, Single-ended output		117		$\text{dB}\mu\text{V}$
NF Noise figure ⁽²⁾	$V_{AGC} = 3\text{ V}$		10		dB
$IM3_{\text{GMX}}$ Third order intermodulation distortion	$f_{\text{IN1}} = 79.5\text{ MHz}$, $f_{\text{IN2}} = 80.5\text{ MHz}$, $V_{\text{OUT}} = -10\text{ dBm}$, $V_{AGC} = 3\text{ V}$		-60		dBc
$OIP3_{\text{GMX}}$ Output intercept point	$f_{\text{IN1}} = 79.5\text{ MHz}$, $f_{\text{IN2}} = 80.5\text{ MHz}$, $V_{AGC} = 3\text{ V}$		20		dBm
IF amplifier ⁽³⁾					
GV_{IFMAX} Maximum voltage gain	$V_{AGC} = 3\text{ V}$		51		dB
GV_{IFMIN} Minimum voltage gain	$V_{AGC} = 0\text{ V}$		46		dB
GVR_{IF} Gain control range	$V_{AGC} = 0\text{ V to } 3\text{ V}$		5		dB
$IM3_{\text{IF}}$ Third order intermodulation distortion	$f_{\text{IN1}} = 43.5\text{ MHz}$, $f_{\text{IN2}} = 445\text{ MHz}$, $V_{\text{IFOUT}} = 1\text{ dBm}$, $V_{AGC} = 3\text{ V}$		-60		dBc
V_{IFOUT} IF amplifier output voltage	$V_{AGC} = 3\text{ V}$, Single-ended output		122		$\text{dB}\mu\text{V}$

- (1) Measurement Circuit 1 except for Noise Figure measurement. AGC IN = 80 MHz/-37 dBm, LO IN = 36 MHz / -20 dBm, IF = 44 MHz, unless otherwise noted.
- (2) Measurement Circuit 2.
- (3) Measurement Circuit 3. IF IN = 44 MHz / -50 dBm, unless otherwise noted.

APPLICATION INFORMATION

MEASUREMENT CIRCUITS

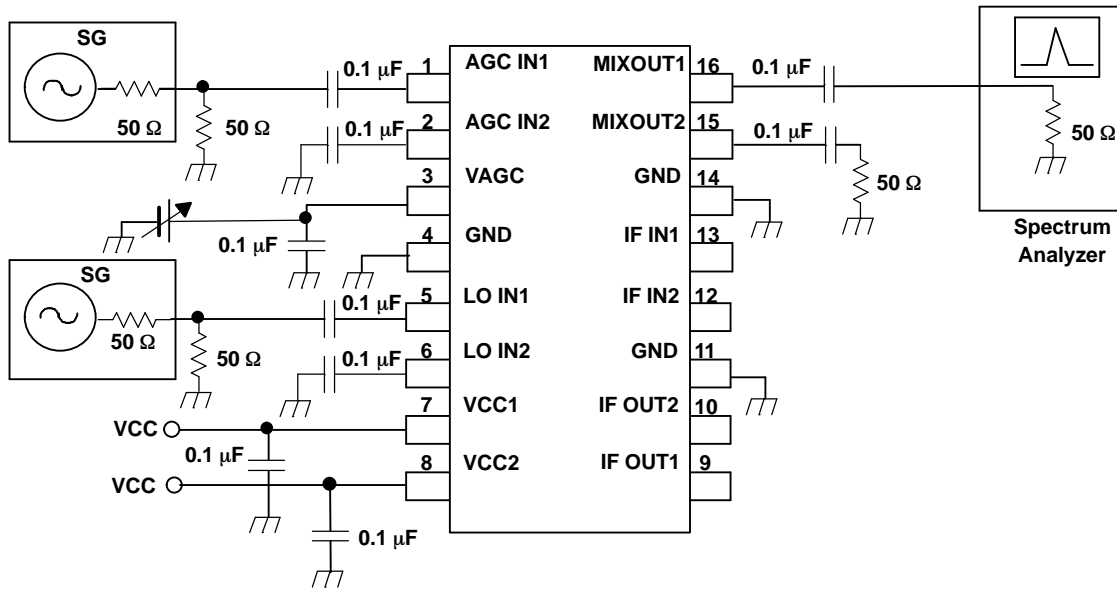

Figure 7. Measurement Circuit 1

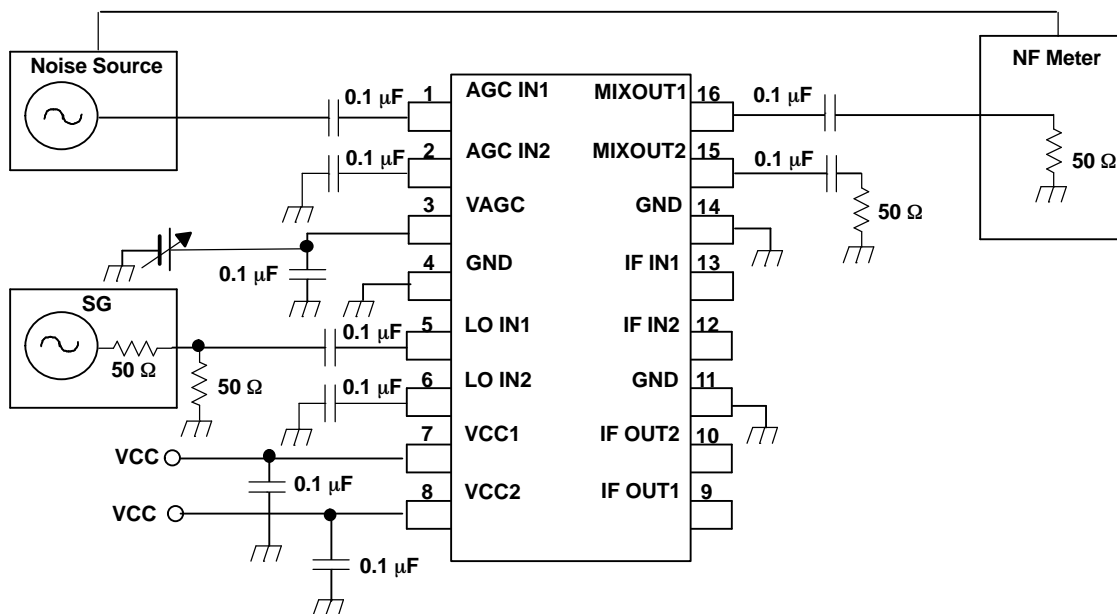

Figure 8. Measurement Circuit 2

APPLICATION INFORMATION (continued)

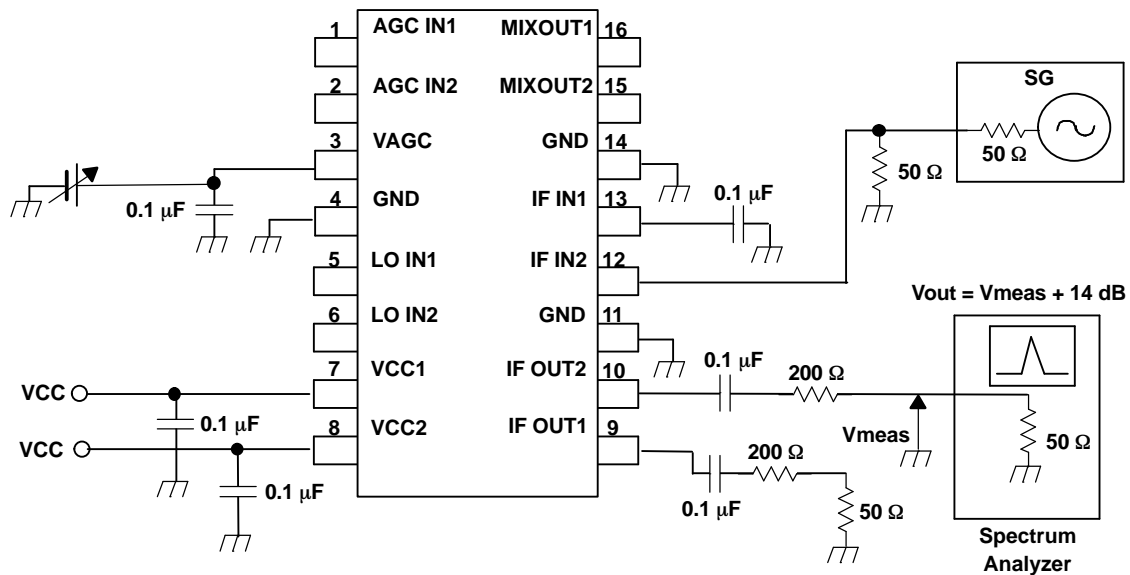

Figure 9. Measurement Circuit 3

NOTE:

This application information is advisory and a performance check is required at the actual application circuits.

Texas Instruments assumes no responsibility for the consequences of use of these application circuits, such as infringement of intellectual property rights or other rights, including patents, of third parties.

TYPICAL CHARACTERISTICS

Mixer Conversion Gain
vs
AGC Control Voltage

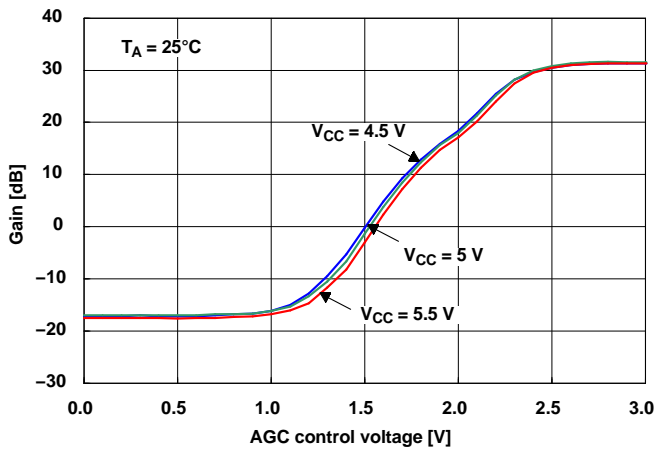

Figure 10.

Mixer Conversion Gain
vs
AGC Control Voltage

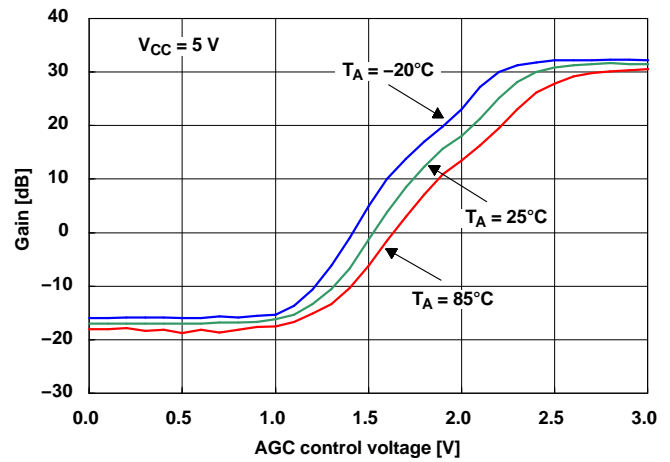

Figure 11.

Mixer Output Level
vs
AGC IN Input Level

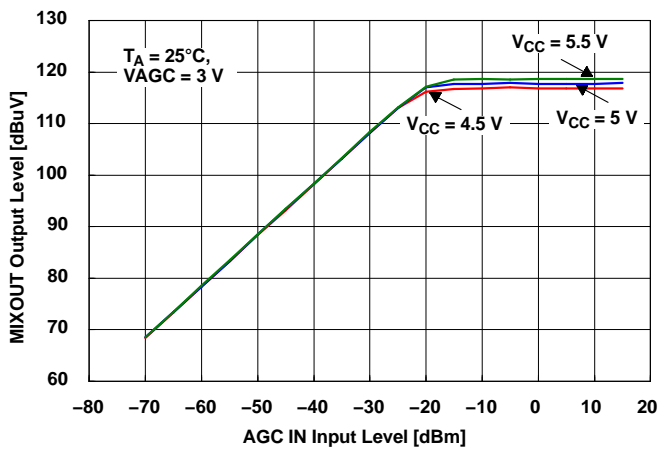

Figure 12.

Mixer Output Level
vs
LO IN Input Level

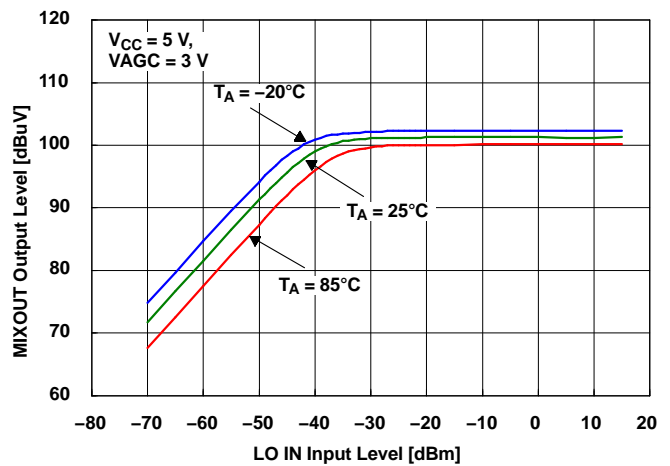

Figure 13.

TYPICAL CHARACTERISTICS (continued)

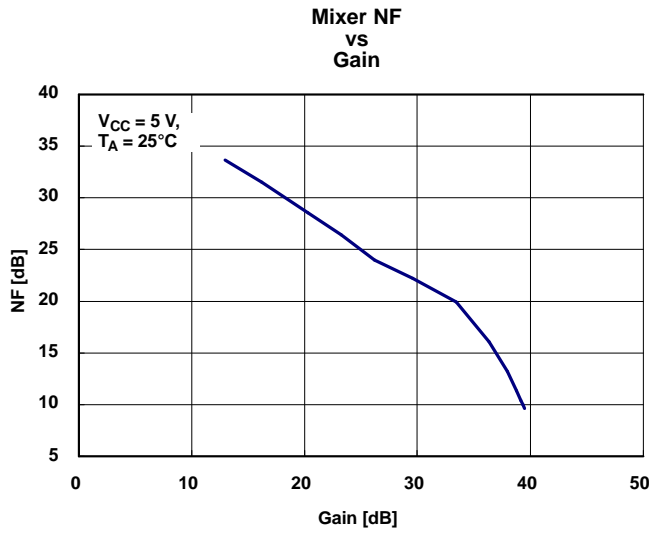

Figure 14.

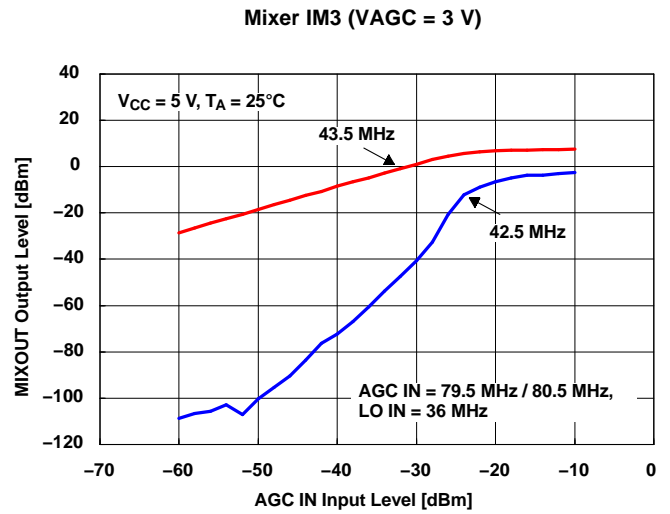

Figure 15.

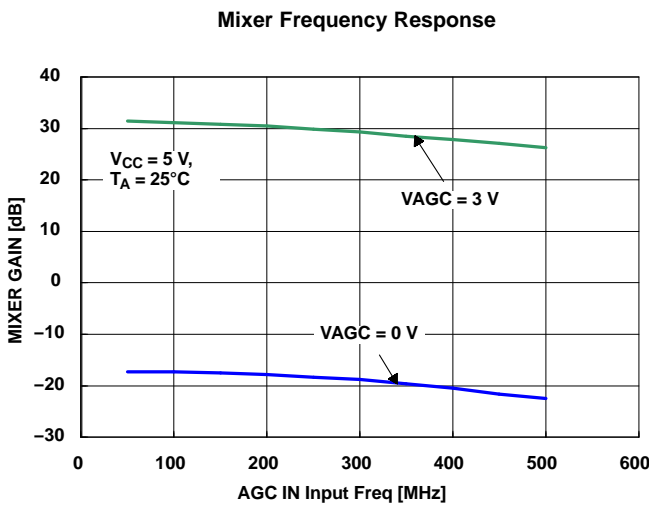

Figure 16.

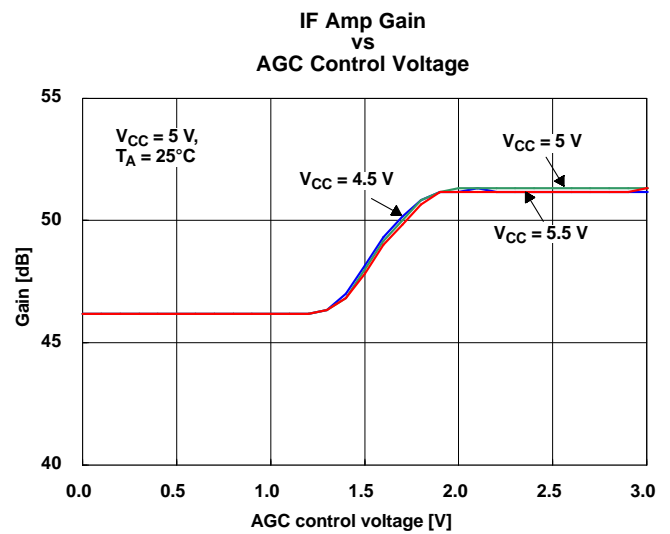

Figure 17.

TYPICAL CHARACTERISTICS (continued)

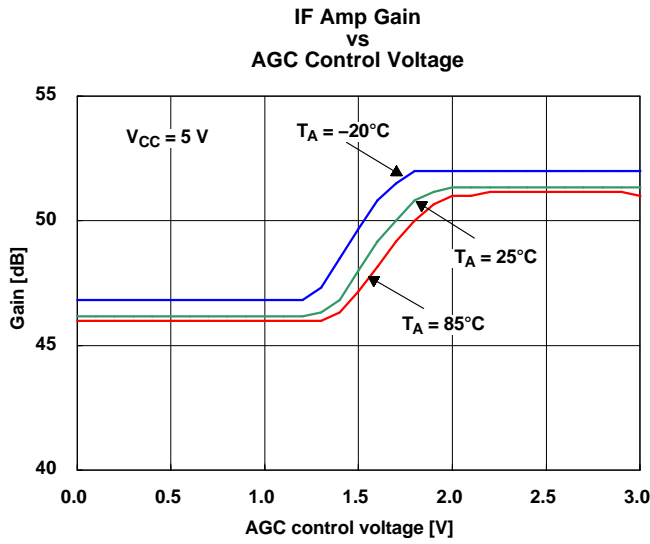

Figure 18.

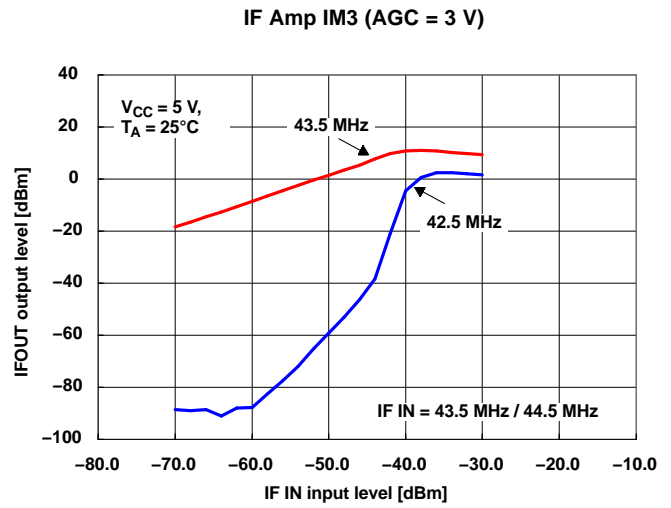

Figure 19.

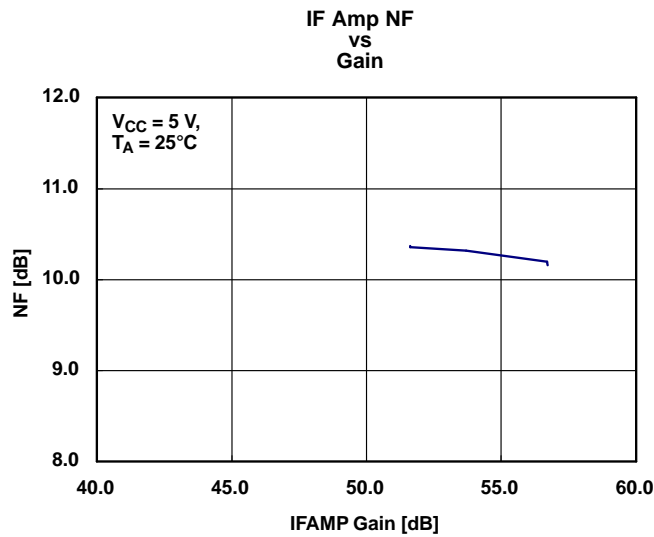

Figure 20.

TYPICAL CHARACTERISTICS (continued)

S-PARAMETER

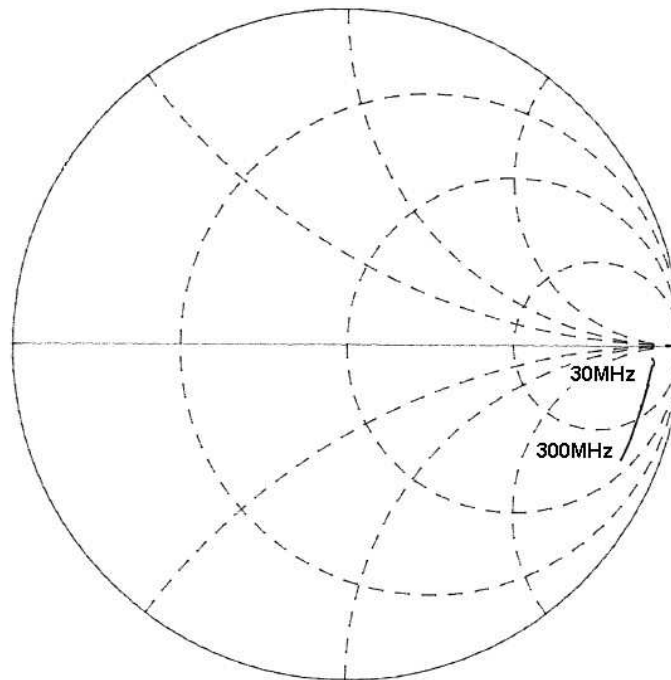

Figure 21. AGC IN

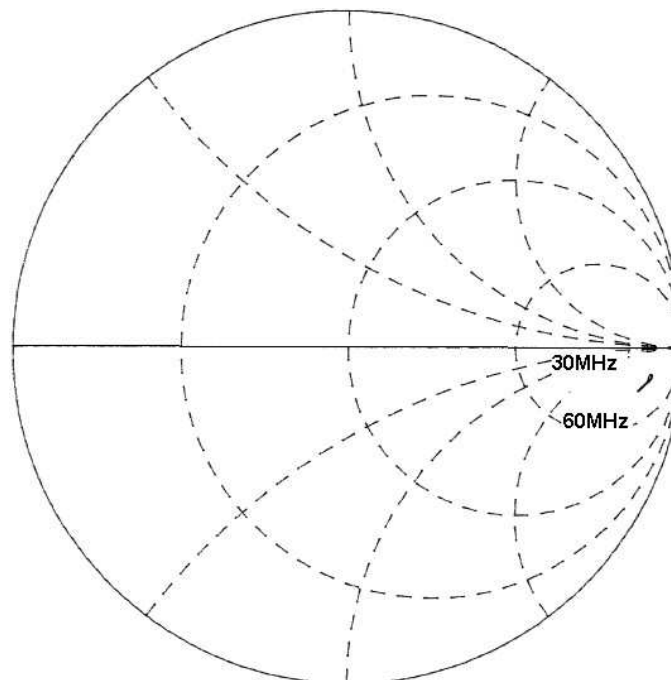

Figure 22. IF IN

TYPICAL CHARACTERISTICS (continued)

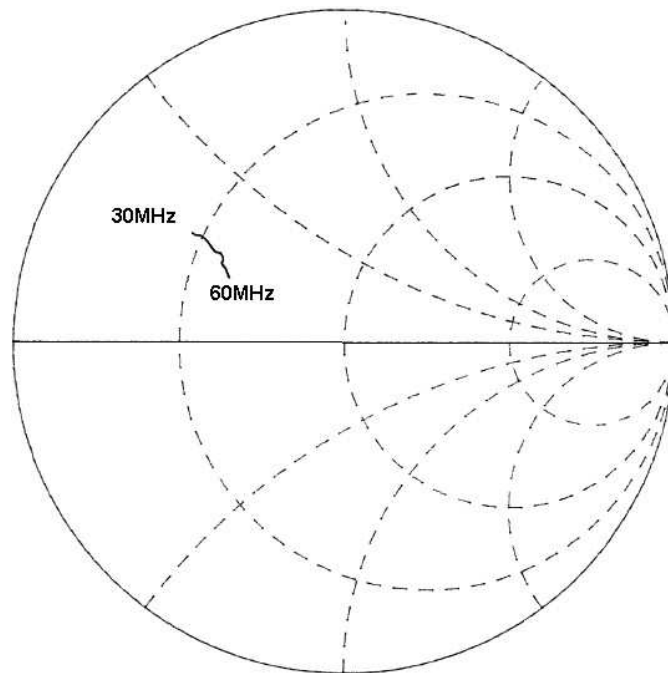

Figure 23. IF OUT

PACKAGING INFORMATION

Orderable Device	Status ⁽¹⁾	Package Type	Package Drawing	Pins	Package Qty	Eco Plan ⁽²⁾	Lead/ Ball Finish	MSL Peak Temp ⁽³⁾	Samples (Requires Login)
SN761688PW	ACTIVE	TSSOP	PW	16		TBD	Call TI	Call TI	
SN761688PWR	ACTIVE	TSSOP	PW	16	2000	Green (RoHS & no Sb/Br)	CU NIPDAU	Level-1-260C-UNLIM	
SN761688PWRG4	ACTIVE	TSSOP	PW	16	2000	Green (RoHS & no Sb/Br)	CU NIPDAU	Level-1-260C-UNLIM	

⁽¹⁾ The marketing status values are defined as follows:

ACTIVE: Product device recommended for new designs.

LIFEBUY: TI has announced that the device will be discontinued, and a lifetime-buy period is in effect.

NRND: Not recommended for new designs. Device is in production to support existing customers, but TI does not recommend using this part in a new design.

PREVIEW: Device has been announced but is not in production. Samples may or may not be available.

OBSOLETE: TI has discontinued the production of the device.

⁽²⁾ Eco Plan - The planned eco-friendly classification: Pb-Free (RoHS), Pb-Free (RoHS Exempt), or Green (RoHS & no Sb/Br) - please check <http://www.ti.com/productcontent> for the latest availability information and additional product content details.

TBD: The Pb-Free/Green conversion plan has not been defined.

Pb-Free (RoHS): TI's terms "Lead-Free" or "Pb-Free" mean semiconductor products that are compatible with the current RoHS requirements for all 6 substances, including the requirement that lead not exceed 0.1% by weight in homogeneous materials. Where designed to be soldered at high temperatures, TI Pb-Free products are suitable for use in specified lead-free processes.

Pb-Free (RoHS Exempt): This component has a RoHS exemption for either 1) lead-based flip-chip solder bumps used between the die and package, or 2) lead-based die adhesive used between the die and leadframe. The component is otherwise considered Pb-Free (RoHS compatible) as defined above.

Green (RoHS & no Sb/Br): TI defines "Green" to mean Pb-Free (RoHS compatible), and free of Bromine (Br) and Antimony (Sb) based flame retardants (Br or Sb do not exceed 0.1% by weight in homogeneous material)

⁽³⁾ MSL, Peak Temp. -- The Moisture Sensitivity Level rating according to the JEDEC industry standard classifications, and peak solder temperature.

Important Information and Disclaimer: The information provided on this page represents TI's knowledge and belief as of the date that it is provided. TI bases its knowledge and belief on information provided by third parties, and makes no representation or warranty as to the accuracy of such information. Efforts are underway to better integrate information from third parties. TI has taken and continues to take reasonable steps to provide representative and accurate information but may not have conducted destructive testing or chemical analysis on incoming materials and chemicals. TI and TI suppliers consider certain information to be proprietary, and thus CAS numbers and other limited information may not be available for release.

In no event shall TI's liability arising out of such information exceed the total purchase price of the TI part(s) at issue in this document sold by TI to Customer on an annual basis.

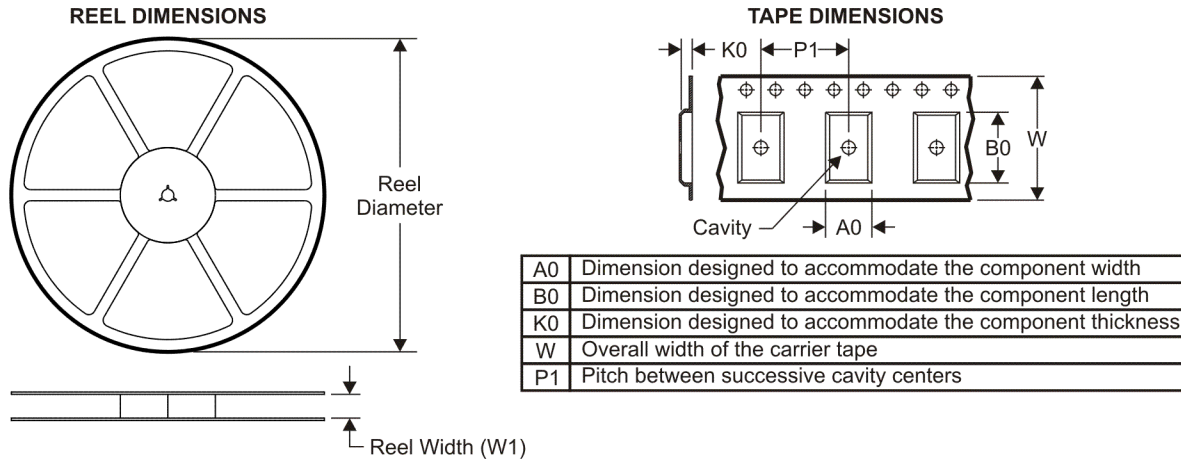
TAPE AND REEL INFORMATION

QUADRANT ASSIGNMENTS FOR PIN 1 ORIENTATION IN TAPE

*All dimensions are nominal

Device	Package Type	Package Drawing	Pins	SPQ	Reel Diameter (mm)	Reel Width W1 (mm)	A0 (mm)	B0 (mm)	K0 (mm)	P1 (mm)	W (mm)	Pin1 Quadrant
SN761688PWR	TSSOP	PW	16	2000	330.0	12.4	6.9	5.6	1.6	8.0	12.0	Q1

TAPE AND REEL BOX DIMENSIONS



*All dimensions are nominal

Device	Package Type	Package Drawing	Pins	SPQ	Length (mm)	Width (mm)	Height (mm)
SN761688PWR	TSSOP	PW	16	2000	346.0	346.0	29.0

PW (R-PDSO-G16)

PLASTIC SMALL OUTLINE

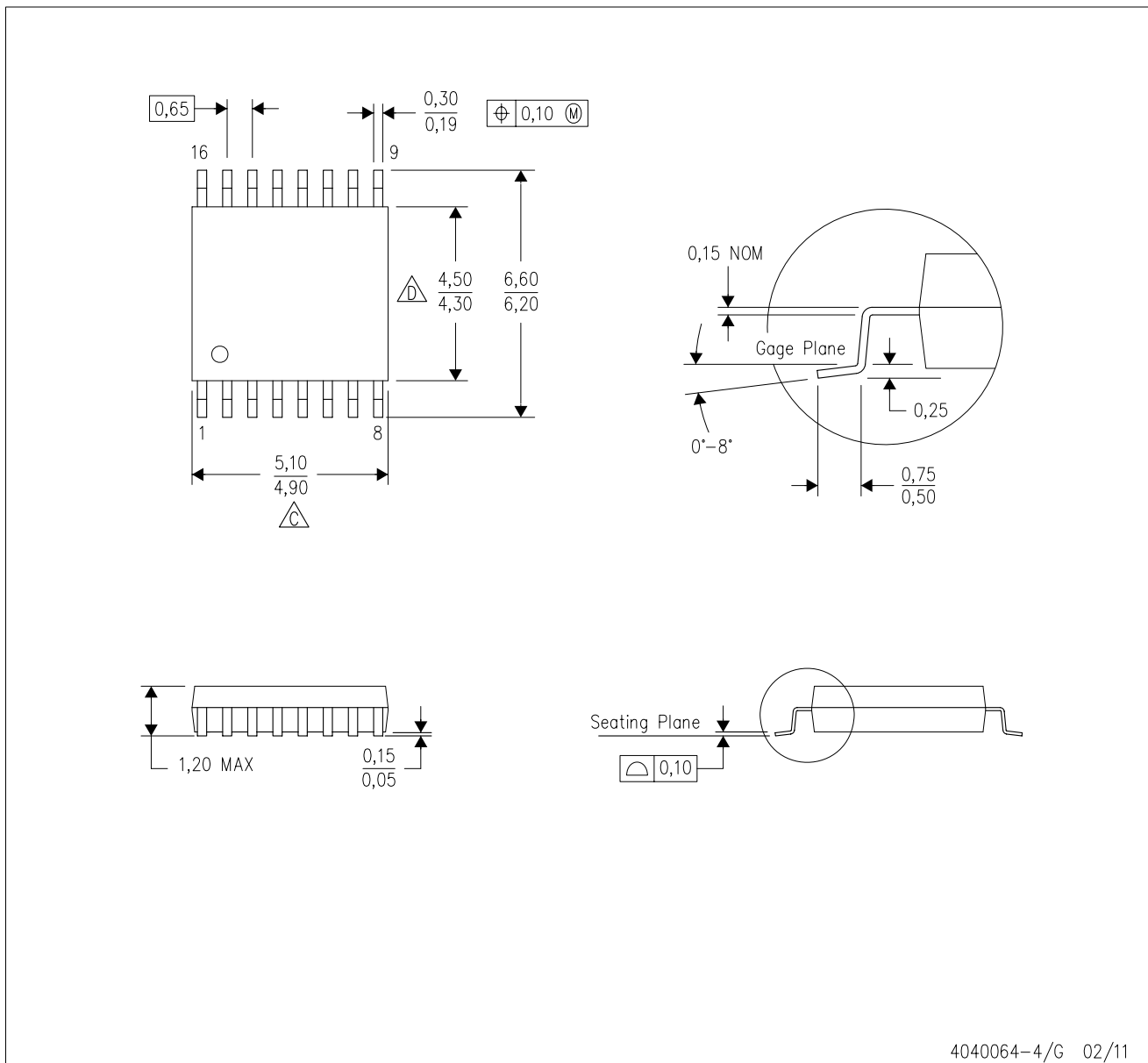

- NOTES:
- A. All linear dimensions are in millimeters. Dimensioning and tolerancing per ASME Y14.5M-1994.
 - B. This drawing is subject to change without notice.
 - C. Body length does not include mold flash, protrusions, or gate burrs. Mold flash, protrusions, or gate burrs shall not exceed 0,15 each side.
 - D. Body width does not include interlead flash. Interlead flash shall not exceed 0,25 each side.
 - E. Falls within JEDEC MO-153

PW (R-PDSO-G16)

PLASTIC SMALL OUTLINE

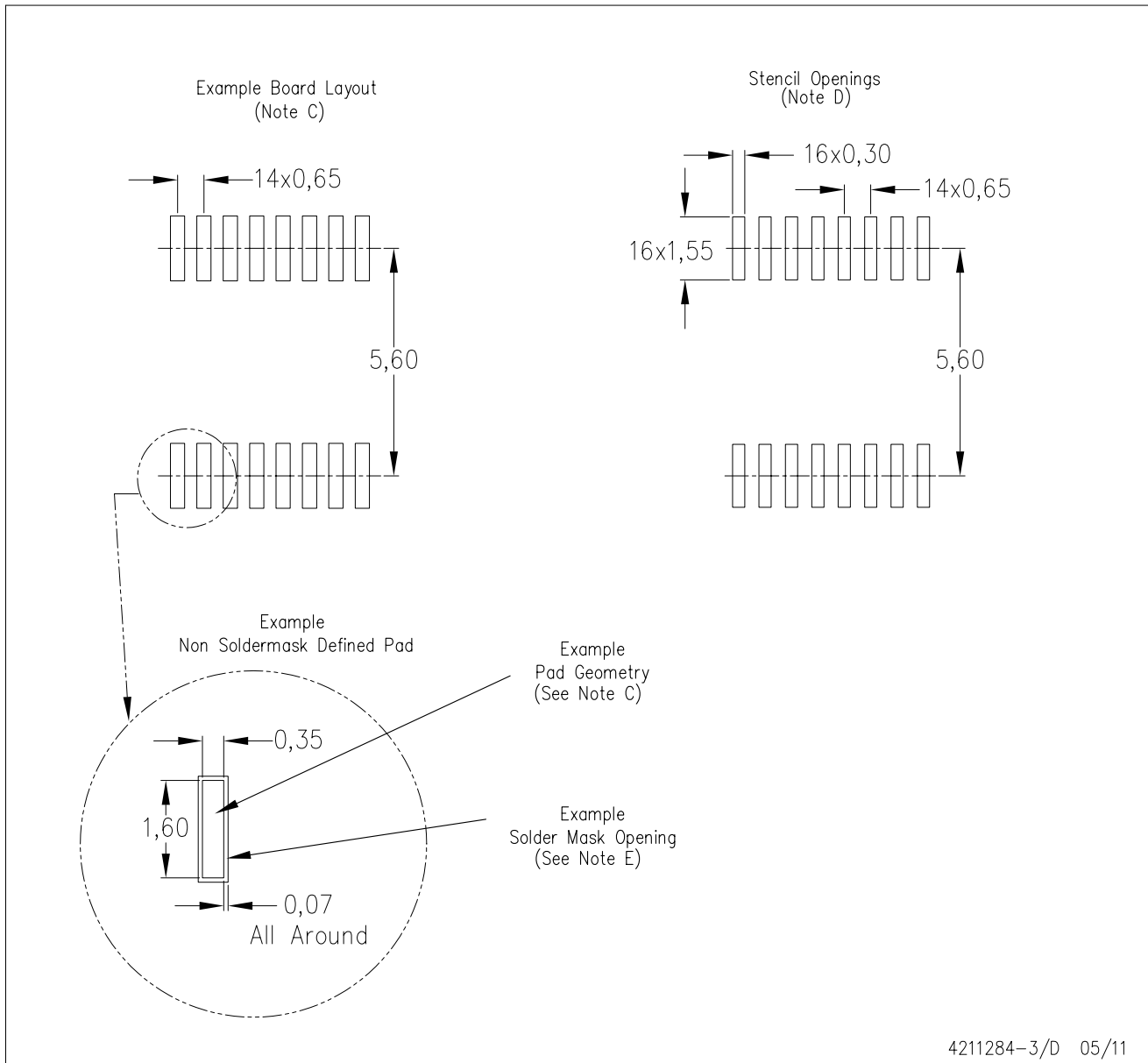

- NOTES:
- All linear dimensions are in millimeters.
 - This drawing is subject to change without notice.
 - Publication IPC-7351 is recommended for alternate designs.
 - Laser cutting apertures with trapezoidal walls and also rounding corners will offer better paste release. Customers should contact their board assembly site for stencil design recommendations. Refer to IPC-7525 for other stencil recommendations.
 - Customers should contact their board fabrication site for solder mask tolerances between and around signal pads.

IMPORTANT NOTICE

Texas Instruments Incorporated and its subsidiaries (TI) reserve the right to make corrections, modifications, enhancements, improvements, and other changes to its products and services at any time and to discontinue any product or service without notice. Customers should obtain the latest relevant information before placing orders and should verify that such information is current and complete. All products are sold subject to TI's terms and conditions of sale supplied at the time of order acknowledgment.

TI warrants performance of its hardware products to the specifications applicable at the time of sale in accordance with TI's standard warranty. Testing and other quality control techniques are used to the extent TI deems necessary to support this warranty. Except where mandated by government requirements, testing of all parameters of each product is not necessarily performed.

TI assumes no liability for applications assistance or customer product design. Customers are responsible for their products and applications using TI components. To minimize the risks associated with customer products and applications, customers should provide adequate design and operating safeguards.

TI does not warrant or represent that any license, either express or implied, is granted under any TI patent right, copyright, mask work right, or other TI intellectual property right relating to any combination, machine, or process in which TI products or services are used. Information published by TI regarding third-party products or services does not constitute a license from TI to use such products or services or a warranty or endorsement thereof. Use of such information may require a license from a third party under the patents or other intellectual property of the third party, or a license from TI under the patents or other intellectual property of TI.

Reproduction of TI information in TI data books or data sheets is permissible only if reproduction is without alteration and is accompanied by all associated warranties, conditions, limitations, and notices. Reproduction of this information with alteration is an unfair and deceptive business practice. TI is not responsible or liable for such altered documentation. Information of third parties may be subject to additional restrictions.

Resale of TI products or services with statements different from or beyond the parameters stated by TI for that product or service voids all express and any implied warranties for the associated TI product or service and is an unfair and deceptive business practice. TI is not responsible or liable for any such statements.

TI products are not authorized for use in safety-critical applications (such as life support) where a failure of the TI product would reasonably be expected to cause severe personal injury or death, unless officers of the parties have executed an agreement specifically governing such use. Buyers represent that they have all necessary expertise in the safety and regulatory ramifications of their applications, and acknowledge and agree that they are solely responsible for all legal, regulatory and safety-related requirements concerning their products and any use of TI products in such safety-critical applications, notwithstanding any applications-related information or support that may be provided by TI. Further, Buyers must fully indemnify TI and its representatives against any damages arising out of the use of TI products in such safety-critical applications.

TI products are neither designed nor intended for use in military/aerospace applications or environments unless the TI products are specifically designated by TI as military-grade or "enhanced plastic." Only products designated by TI as military-grade meet military specifications. Buyers acknowledge and agree that any such use of TI products which TI has not designated as military-grade is solely at the Buyer's risk, and that they are solely responsible for compliance with all legal and regulatory requirements in connection with such use.

TI products are neither designed nor intended for use in automotive applications or environments unless the specific TI products are designated by TI as compliant with ISO/TS 16949 requirements. Buyers acknowledge and agree that, if they use any non-designated products in automotive applications, TI will not be responsible for any failure to meet such requirements.

Following are URLs where you can obtain information on other Texas Instruments products and application solutions:

Products

Audio	www.ti.com/audio
Amplifiers	amplifier.ti.com
Data Converters	dataconverter.ti.com
DLP® Products	www.dlp.com
DSP	dsp.ti.com
Clocks and Timers	www.ti.com/clocks
Interface	interface.ti.com
Logic	logic.ti.com
Power Mgmt	power.ti.com
Microcontrollers	microcontroller.ti.com
RFID	www.ti-rfid.com
OMAP Mobile Processors	www.ti.com/omap
Wireless Connectivity	www.ti.com/wirelessconnectivity

Applications

Communications and Telecom	www.ti.com/communications
Computers and Peripherals	www.ti.com/computers
Consumer Electronics	www.ti.com/consumer-apps
Energy and Lighting	www.ti.com/energy
Industrial	www.ti.com/industrial
Medical	www.ti.com/medical
Security	www.ti.com/security
Space, Avionics and Defense	www.ti.com/space-avionics-defense
Transportation and Automotive	www.ti.com/automotive
Video and Imaging	www.ti.com/video

TI E2E Community Home Page

e2e.ti.com

Mailing Address: Texas Instruments, Post Office Box 655303, Dallas, Texas 75265
Copyright © 2011, Texas Instruments Incorporated

Looking for pricing, stock, or lifecycle information?

Click below to explore more details on WIN SOURCE:

 [View SN761688PWRG4 on WIN SOURCE](#)

 [Texas Instruments](#) Information

Optimize Your Supply Chain with WIN SOURCE Solutions

-  Global Sourcing Solution
-  Obsolete Management
-  Cost Control Management
-  Shortage Management
-  Alternative Solution
-  Excess Inventory Management