



**THE DATASHEET OF
SIP-0P5WRS301**





SAMSUNG
ARTIK[™] Modules

0

ARTIK 053 Datasheet

MODULE OVERVIEW

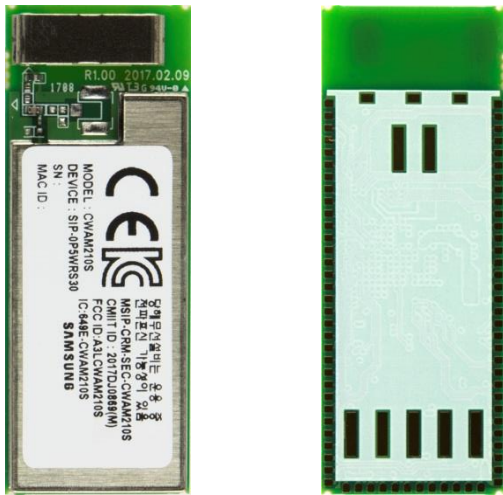

Top View (Left) and Bottom View (Right) of ARTIK 053 Module

The Samsung ARTIK™ 053 Module is a highly integrated module for secure Internet of Things (IoT) devices that require Wi-Fi® Connectivity. It is based on an ARM® Cortex® R4 core, with on-module RAM and flash memory, a complete 2.4GHz Wi-Fi subsystem with on-module antenna, an independent security subsystem, PUF-based module authentication, and a large complement of standard I/O interfaces.

ARTIK 053 Module provides excellent performance in a variety of environments, with a feature set tailored specifically for IoT end nodes.

Processor	
CPU	32 bit ARM® Cortex® R4 with 32KB I-Cache and 32KB D-Cache 320MHz
Memory	
RAM	1280KB (General usage) 128KB (Global IPC data)
FLASH	8MB flash
Security	
Secure System	AES/DES/TDES, SHA-1/SHA-2, PKA (Public Key Accelerator), PRNG/DTRNG (Random Number Generators), Secure key storage
PUF	Physically Unclonable Function
Radio	
Wi-Fi	Certified IEEE802.11™ b/g/n Wi-Fi® 2.4GHz radio
Regulatory	FCC (U.S.), IC (Canada), CE (EU), KC (Korea), SRRC (China)
Power Management	
Single Supply	Wide voltage input range 5-12V
Interfaces	
I/O	UART, I ² C, SPI, PWM, ADC, GPIO
Form Factor	
Dimensions	15x40x3mm (WxHxD)

TABLE OF CONTENTS

Module Overview	2
Table of Contents	3
List of Figures	4
List of Tables	4
Version History	5
Block Diagram.....	6
CPU.....	6
Memory.....	6
Real Time Clock.....	6
PUF Unit.....	7
Security Subsystem	7
Wi-Fi Subsystem	7
UART Interface.....	7
GPIO Interface.....	7
I ² C Interface.....	7
PWM Interface.....	8
SPI Interface	8
ADC Interface.....	8
Module Edge Pinout.....	9
Module Edge Pinout by Function	12
ADC Interface.....	12
Debug Interface.....	12
I ² C Interface.....	12
INT Interface.....	12
Power Interface.....	12
GPIO Interface.....	13
PWM Interface.....	13
Reset Interface.....	13
SPI Interface	14
UART Interface.....	14
Electrical Specifications	15
Absolute Maximum Rating.....	15
DC Electrical Characteristics.....	15
ESD Ratings.....	16
AC Electrical Characteristics	16
RF Electrical Characteristics.....	16
Mechanical Specifications	17
Module Antenna Placement Requirements.....	18
Certification.....	19
FCC Regulatory Disclosures.....	19
Industry Canada Regulatory Disclosures	20
EU Regulatory Disclosures	21
Ordering Information	22
Legal Information.....	23

LIST OF FIGURES

Figure 1. ARTIK 053 Module Block Diagram	6
Figure 2. ADC LSB behavior	8
Figure 3. ARTIK 053 Module Edge Pinout.....	9
Figure 4. ARTIK 053 Module Mechanical Dimensions	17
Figure 5. Module Placement Restrictions	18

LIST OF TABLES

Table 1. ARTIK 053 Module Edge Pinout Signal Descriptions.....	10
Table 2. ADC Interface	12
Table 3. Debug Interface	12
Table 4. I ² C Interface	12
Table 5. Interrupt Interface.....	12
Table 6. GPIO Interface.....	13
Table 7. PWM Interface.....	13
Table 8. Reset Interface	13
Table 9. SPI Interface	14
Table 10. UART Interface	14
Table 11. Absolute Maximum Ratings	15
Table 12. I/O DC Electrical Characteristics (PAD: [2-13, 18, 19], [21-26], [28-31], [33-45], [48-75], I/O)	15
Table 13. I/O DC Electrical Characteristics (PAD: [14-17], ADC).....	15
Table 14. Recommended Operating Conditions.....	16
Table 15. GPIO Signal Drive Strength	16
Table 16. ESD Ratings	16
Table 17. Level Shifter AC Electrical Characteristics	16
Table 18. Tx Performance Characteristics	16
Table 19. Rx Performance Characteristics	16

VERSION HISTORY

Revision	Date	Description	Maturity
V1.0	04/26/2017	Public release Datasheet	Release

BLOCK DIAGRAM

Figure 1 shows the functional Block Diagram of the ARTIK 053 Module.

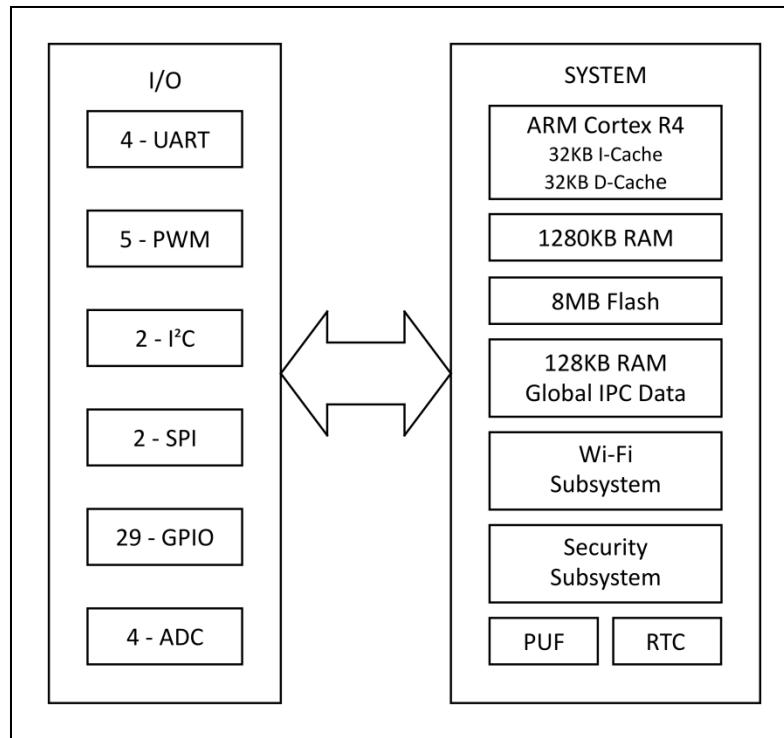

Figure 1. ARTIK 053 Module Block Diagram

CPU

The ARTIK 053 Module CPU has an ARM® Cortex® R4. It has the following features:

- 32KB of Instruction Cache (I-Cache)
- 32KB of Data Cache (D-Cache)
- 320 MHz execution clock
- R4 core tuned for embedded and real-time applications

MEMORY

The ARTIK 053 Module on-module memory has the following features:

- CPU and general purpose RAM
 - 1280KB CPU RAM
 - 128KB global Inter-Process Communication (IPC) RAM
- 8MB flash

REAL TIME CLOCK

The ARTIK 053 Module has a Real Time Clock (RTC) for tracking date/time. The RTC has the following features:

- Binary-Coded Decimal (BCD) coded seconds, minutes, hour, day of the week, day, month, and year
- Leap year detection and compensation
- Millisecond tick time interrupt for Real-Time Operating System (RTOS) kernel time tick

PUF UNIT

The ARTIK 053 Module has a Physically Unclonable Function (PUF) unit. The PUF unit has the following features:

- Generates unique key values, locked to an individual ARTIK 053 Module
- The algorithm construction is unique to each module
- Allows individual ARTIK 053 Modules to be “fingerprint-identified”

SECURITY SUBSYSTEM

The ARTIK 053 Module has an independent security subsystem to ensure secure end-to-end operation in any IoT environment. The security subsystem includes the following features:

- Protected Execution Environment
 - Secure IPC Mailbox for inter-subsystem communication
 - Encapsulated key support
 - Backup encryption key - 256 bits
 - Security subsystem root private key - 521 bits
 - Storage key - 256 bits
- Symmetric key engines
 - Secure AES
 - Secure DES/Triple-DES
- Stream cipher engine
 - ARC4 engine
- Various Hash engines
 - SHA-1, SHA2-256, SHA2-384, SHA2-512, MD5 HMAC
- Asymmetric key engines
 - PKA (Public Key Accelerator) engine
- PRNG (Pseudo Random Number Generator)
- DTRNG (Digital True Random Number Generator)
- Secure key storage

WI-FI SUBSYSTEM

The ARTIK 053 Module has an 802.11b/g/n Wi-Fi subsystem. The Wi-Fi subsystem has the following features:

- 802.11™ b/g/n support at 2.4GHz
- 20MHz single stream (802.11n)
- WPA/WPA2/WAPI
- Dedicated Wi-Fi Processor subsystem

UART INTERFACE

The ARTIK 053 Module has four 2-pin UART interfaces, each with the following features:

- Can be operated in DMA or interrupt-based mode
- Support for 5, 6, 7 or 8 bit serial data transmit and receive
- Programmable baud rate
- One or two stop bit insertion

GPIO INTERFACE

The ARTIK 053 Module has flexible General Purpose Input Output (GPIO) interfaces:

- 29 configurable GPIO ports
- Independently configurable for either input or output
- Configurable internal pull-up or pull-down resistors

I²C INTERFACE

The ARTIK 053 Module has two high speed multi-master I²C interfaces available, with speeds up to 3.4Mbps.

PWM INTERFACE

The ARTIK 053 Module has five PWM timers available, each with the following features:

- 32 bits of resolution for each PWM signal
- Two 8 bit pre-scalers (first level of division) and 5 clock-dividers/multiplexers for second level division
- Continuous run or one-shot pulse mode
- Dead zone generator to avoid simultaneous change of multiple PWM signals
- Interrupt generation

SPI INTERFACE

The ARTIK 053 Module has two SPI interfaces, each with the following features:

- Full duplex communication
- 8, 16 or 32 bit shift registers and bus interface
- Motorola SPI protocol and National Semiconductor Microwire protocol
- Master and slave mode operation
- Two independent 32 bit wide transmit/receive FIFOs
- Transmit and receive speeds up to 50MHz

ADC INTERFACE

The ARTIK 053 Module has four channels of analog-to-digital converter. The A/D interface has the following features:

- 12 bit resolution
- ADC conversion clock at 1.08 MSPS (Sampling per Second) using a main 6.5 MHz clock
- Support sample averaging over 1, 2, 4, 8, 16, 32, 64 samples
- Differential non-linearity error ± 2 LSB
- Integral non-linearity error ± 6 LSB
- Top offset error ± 10 LSB
- Bottom offset error ± 10 LSB
- Voltage range up to 1.8V

Figure 2 depicts the dynamic behavior between input voltage on the ADC and resulting LSB value in the ADC register.

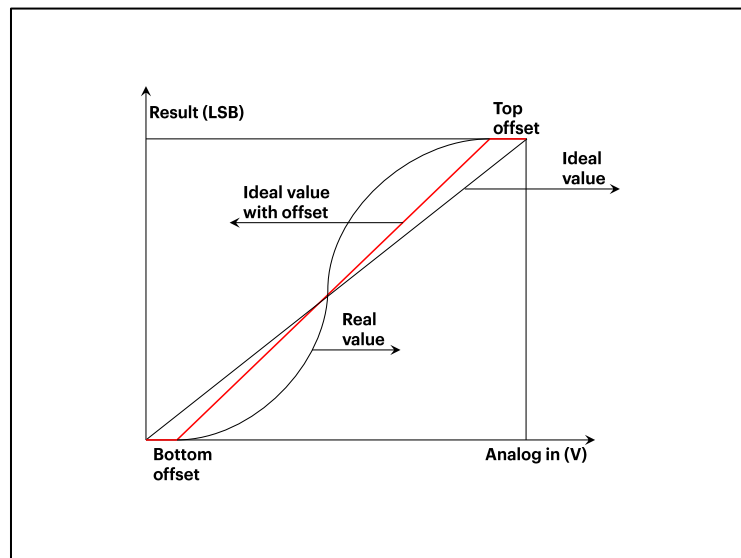

Figure 2. ADC LSB behavior

MODULE EDGE PINOUT

The ARTIK 053 Module utilizes 79 signal, power, and ground pads. *Figure 3* shows how the Edge Pinout is oriented and how signal coordinates are assigned to the edge of the ARTIK 053 Module. *Table 1* shows the edge pads and the signal names.

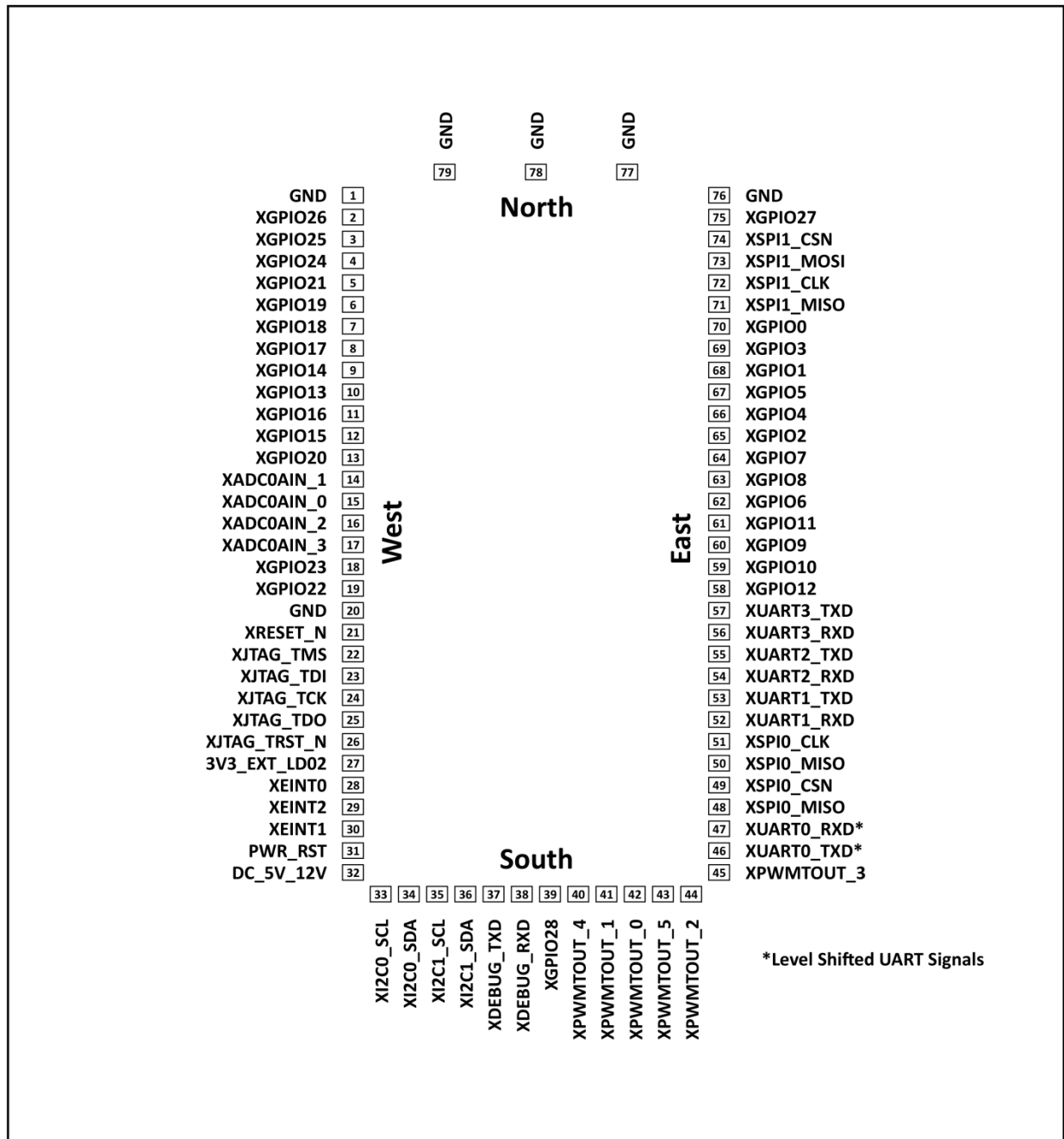

Figure 3. ARTIK 053 Module Edge Pinout

Table 1. ARTIK 053 Module Edge Pinout Signal Descriptions

Pad Number	Pad Name	I/O Type*	PU/PD	Power	Default Function
1	GND	-	-	-	GND
2	XGPIO26	I	PD	VDDQ33_EXT0	GPIO
3	XGPIO25	I	PD	VDDQ33_EXT0	GPIO
4	XGPIO24	I	PD	VDDQ33_EXT0	GPIO
5	XGPIO21	I	PD	VDDQ33_EXT0	GPIO
6	XGPIO19	I	PD	VDDQ33_EXT0	GPIO
7	XGPIO18	I	PD	VDDQ33_EXT0	GPIO
8	XGPIO17	I	PD	VDDQ33_EXT0	GPIO
9	XGPIO14	I	PD	VDDQ33_EXT0	GPIO
10	XGPIO13	I	PD	VDDQ33_EXT0	GPIO
11	XGPIO16	I	PD	VDDQ33_EXT0	GPIO
12	XGPIO15	I	PD	VDDQ33_EXT0	GPIO
13	XGPIO20	I	PD	VDDQ33_EXT0	GPIO
14	XADC0AIN_1	-	-	AVDD18_ADC0	ADC
15	XADC0AIN_0	-	-	AVDD18_ADC0	ADC
16	XADC0AIN_2	-	-	AVDD18_ADC0	ADC
17	XADC0AIN_3	-	-	AVDD18_ADC0	ADC
18	XGPIO23	I	PD	VDDQ1833_SDIO_0	GPIO
19	XGPIO22	I	PD	VDDQ1833_SDIO_0	GPIO
20	GND	-	-	-	GND
21	XRESET_N	I	-	VDDQ33_EXT1	RESET
22	XJTAG_TMS	I	PU	VDDQ33_EXT1	DEBUG
23	XJTAG_TDI	I	PU	VDDQ33_EXT1	DEBUG
24	XJTAG_TCK	I	PD	VDDQ33_EXT1	DEBUG
25	XJTAG_TDO	I	PD	VDDQ33_EXT1	DEBUG
26	XJTAG_TRST_N	I	PD	VDDQ33_EXT1	DEBUG
27	3V3_EXT_LDO2	-	-	-	POWER
28	XEINT_0	I	PD	VDDQ33_EXT1	INT
29	XEINT_2	I	PD	VDDQ33_EXT1	INT
30	XEINT_1	I	PD	VDDQ33_EXT1	INT
31	PWR_RST	-	-	-	RESET
32	DC_5V_12V	-	-	-	POWER
33	XI2C0_SCL	I	PD	VDDQ33_EXT1	I2C
34	XI2C0_SDA	I	PD	VDDQ33_EXT1	I2C
35	XI2C1_SCL	I	PD	VDDQ33_EXT1	I2C
36	XI2C1_SDA	I	PD	VDDQ33_EXT1	I2C
37	XDEBUG_TXD	I	PD	VDDQ33_EXT1	DEBUG
38	XDEBUG_RXD	I	PD	VDDQ33_EXT1	DEBUG
39	XGPIO28	I	PD	VDDQ33_EXT0	GPIO
40	XPWMTOUT_4	I	PD	VDDQ33_EXT0	PWM
41	XPWMTOUT_1	I	PD	VDDQ33_EXT0	PWM
42	XPWMTOUT_0	I	PD	VDDQ33_EXT0	PWM
43	XPWMTOUT_5	I	PD	VDDQ33_EXT0	PWM
44	XPWMTOUT_2	I	PD	VDDQ33_EXT0	PWM
45	XPWMTOUT_3	I	PD	VDDQ33_EXT0	PWM
46	XUART0_TXD	-	-	-	LEVEL SHIFTED
47	XUART0_RXD	-	-	-	LEVEL SHIFTED
48	XSPI0_MISO	I	PD	VDDQ33_EXT0	SPI
49	XSPI0_CSN	I	PD	VDDQ33_EXT0	SPI
50	XSPI0_MOSI	I	PD	VDDQ33_EXT0	SPI
51	XSPI0_CLK	I	PD	VDDQ33_EXT0	SPI

Pad Number	Pad Name	I/O Type*	PU/PD	Power	Default Function
52	XUART1_TXD	I	PD	VDDQ33_EXT0	UART
53	XUART1_RXD	I	PD	VDDQ33_EXT0	UART
54	XUART2_RXD	I	PD	VDDQ33_EXT0	UART
55	XUART2_TXD	I	PD	VDDQ33_EXT0	UART
56	XUART3_RXD	I	PD	VDDQ33_EXT0	UART
57	XUART3_TXD	I	PD	VDDQ33_EXT0	UART
58	XGPIO12	I	PD	VDDQ33_EXT0	GPIO
59	XGPIO10	I	PD	VDDQ33_EXT0	GPIO
60	XGPIO9	I	PD	VDDQ33_EXT0	GPIO
61	XGPIO11	I	PD	VDDQ33_EXT0	GPIO
62	XGPIO6	I	PD	VDDQ33_EXT0	GPIO
63	XGPIO8	I	PD	VDDQ33_EXT0	GPIO
64	XGPIO7	I	PD	VDDQ33_EXT0	GPIO
65	XGPIO2	I	PD	VDDQ33_EXT0	GPIO
66	XGPIO4	I	PD	VDDQ33_EXT0	GPIO
67	XGPIO5	I	PD	VDDQ33_EXT0	GPIO
68	XGPIO1	I	PD	VDDQ33_EXT0	GPIO
69	XGPIO3	I	PD	VDDQ33_EXT0	GPIO
70	XGPIO0	I	PD	VDDQ33_EXT0	GPIO
71	XSPI1_MISO	I	PD	VDDQ33_EXT0	SPI
72	XSPI1_CLK	I	PD	VDDQ33_EXT0	SPI
73	XSPI1_MOSI	I	PD	VDDQ33_EXT0	SPI
74	XSPI1_CSN	I	PD	VDDQ33_EXT0	SPI
75	XGPIO27	I	PD	VDDQ33_EXT0	GPIO
76	GND	-	-	-	GND

Note:

- * Default setting after reset
- I/O pad type definition - I:input, O:output, I/O:input/output
- Internal pull up/pull down definition - PU:pull-up, PD:pull-down, N:no pull

MODULE EDGE PINOUT BY FUNCTION

ADC INTERFACE

Table 2. ADC Interface

Pad Number	Pad Name	I/O Type	PU/PD	Power	Default Function
14	XADC0AIN_1	-	-	AVDD18_ADC0	XADC0AIN_1
15	XADC0AIN_0	-	-	AVDD18_ADC0	XADC0AIN_0
16	XADC0AIN_2	-	-	AVDD18_ADC0	XADC0AIN_2
17	XADC0AIN_3	-	-	AVDD18_ADC0	XADC0AIN_3

DEBUG INTERFACE

Table 3. Debug Interface

Pad Number	Pad Name	I/O Type	PU/PD	Power	Default Function
22	XJTAG_TMS	I	PU	VDDQ33_EXT1	XJTAG_TMS
23	XJTAG_TDI	I	PU	VDDQ33_EXT1	XJTAG_TDI
24	XJTAG_TCK	I	PD	VDDQ33_EXT1	XJTAG_TCK
25	XJTAG_TDO	I	PD	VDDQ33_EXT1	XJTAG_TDO
26	XJTAG_TRST_N	I	PD	VDDQ33_EXT1	XJTAG_TRST_N
37	XDEBUG_TXD	I	PD	VDDQ33_EXT1	XDEBUG_TXD
38	XDEBUG_RXD	I	PD	VDDQ33_EXT1	XDEBUG_RXD

I²C INTERFACE

Table 4. I²C Interface

Pad Number	Pad Name	I/O Type	PU/PD	Power	Default Function
33	XI2C0_SCL	I	PD	VDDQ33_EXT1	XI2C0_SCL
34	XI2C0_SDA	I	PD	VDDQ33_EXT1	XI2C0_SDA
35	XI2C1_SCL	I	PD	VDDQ33_EXT1	XI2C1_SCL
36	XI2C1_SDA	I	PD	VDDQ33_EXT1	XI2C1_SDA

INT INTERFACE

Table 5. Interrupt Interface

Pad Number	Pad Name	I/O Type	PU/PD	Power	Default Function
28	XEINT_0	I	PD	VDDQ33_EXT1	XEINT_0
29	XEINT_2	I	PD	VDDQ33_EXT1	XEINT_2
30	XEINT_1	I	PD	VDDQ33_EXT1	XEINT_1

POWER INTERFACE

Pad Number	Pad Name	I/O Type	PU/PD	Power	Default Function
1	GND	-	-	-	-
20	GND	-	-	-	-
27	3V3_EXT_LDO2	-	-	-	-
32	DC_5V_12V	-	-	-	-
76	GND	-	-	-	-

GPIO INTERFACE

Table 6. GPIO Interface

Pad Number	Pad Name	I/O Type	PU/PD	Power	Default Function
2	XGPIO26	I	PD	VDDQ33_EXT0	XGPIO26
3	XGPIO25	I	PD	VDDQ33_EXT0	XGPIO25
4	XGPIO24	I	PD	VDDQ33_EXT0	XGPIO24
5	XGPIO21	I	PD	VDDQ33_EXT0	XGPIO21
6	XGPIO19	I	PD	VDDQ33_EXT0	XGPIO19
7	XGPIO18	I	PD	VDDQ33_EXT0	XGPIO18
8	XGPIO17	I	PD	VDDQ33_EXT0	XGPIO17
9	XGPIO14	I	PD	VDDQ33_EXT0	XGPIO14
10	XGPIO13	I	PD	VDDQ33_EXT0	XGPIO13
11	XGPIO16	I	PD	VDDQ33_EXT0	XGPIO16
12	XGPIO15	I	PD	VDDQ33_EXT0	XGPIO15
13	XGPIO20	I	PD	VDDQ33_EXT0	XGPIO20
18	XGPIO23	I	PD	VDDQ1833_SDIO_0	XGPIO23
19	XGPIO22	I	PD	VDDQ1833_SDIO_0	XGPIO22
39	XGPIO28	I	PD	VDDQ33_EXT0	XGPIO28
58	XGPIO12	I	PD	VDDQ33_EXT0	XGPIO12
59	XGPIO10	I	PD	VDDQ33_EXT0	XGPIO10
60	XGPIO9	I	PD	VDDQ33_EXT0	XGPIO9
61	XGPIO11	I	PD	VDDQ33_EXT0	XGPIO11
62	XGPIO6	I	PD	VDDQ33_EXT0	XGPIO6
63	XGPIO8	I	PD	VDDQ33_EXT0	XGPIO8
64	XGPIO7	I	PD	VDDQ33_EXT0	XGPIO7
65	XGPIO2	I	PD	VDDQ33_EXT0	XGPIO2
66	XGPIO4	I	PD	VDDQ33_EXT0	XGPIO4
67	XGPIO5	I	PD	VDDQ33_EXT0	XGPIO5
68	XGPIO1	I	PD	VDDQ33_EXT0	XGPIO1
69	XGPIO3	I	PD	VDDQ33_EXT0	XGPIO3
70	XGPIO0	I	PD	VDDQ33_EXT0	XGPIO0
75	XGPIO27	I	PD	VDDQ33_EXT0	XGPIO27

PWM INTERFACE

Table 7. PWM Interface

Pad Number	Pad Name	I/O Type	PU/PD	Power	Default Function
40	XPWMTOUT_4	I	PD	VDDQ33_EXT0	XPWMTOUT_4
41	XPWMTOUT_1	I	PD	VDDQ33_EXT0	XPWMTOUT_1
42	XPWMTOUT_0	I	PD	VDDQ33_EXT0	XPWMTOUT_0
43	XPWMTOUT_5	I	PD	VDDQ33_EXT0	XPWMTOUT_5
44	XPWMTOUT_2	I	PD	VDDQ33_EXT0	XPWMTOUT_2
45	XPWMTOUT_3	I	PD	VDDQ33_EXT0	XPWMTOUT_3

RESET INTERFACE

Table 8. Reset Interface

Pad Number	Pad Name	I/O Type	PU/PD	Power	Default Function
21	XRESET_N	I	-	VDDQ33_EXT1	XRESET_N
31	PWR_RST	-	-	-	-

SPI INTERFACE

Table 9. SPI Interface

Pad Number	Pad Name	I/O Type	PU/PD	Power	Default Function
48	XSPIO_MISO	I	PD	VDDQ33_EXT0	XSPIO_MISO
49	XSPIO_CSN	I	PD	VDDQ33_EXT0	XSPIO_CSN
50	XSPIO_MOSI	I	PD	VDDQ33_EXT0	XSPIO_MOSI
51	XSPIO_CLK	I	PD	VDDQ33_EXT0	XSPIO_CLK
71	XSPI1_MISO	I	PD	VDDQ33_EXT0	XSPI1_MISO
72	XSPI1_CLK	I	PD	VDDQ33_EXT0	XSPI1_CLK
73	XSPI1_MOSI	I	PD	VDDQ33_EXT0	XSPI1_MOSI
74	XSPI1_CSN	I	PD	VDDQ33_EXT0	XSPI1_CSN

UART INTERFACE

Table 10. UART Interface

Pad Number	Pad Name	I/O Type	PU/PD	Power	Default Function	Comment
46	XUART0_TXD	-	-	-	XUART0_TXD	Through Level Shifter
47	XUART0_RXD	-	-	-	XUART0_RXD	Through Level Shifter
52	XUART1_TXD	I	PD	VDDQ33_EXT0	XUART1_TXD	-
53	XUART1_RXD	I	PD	VDDQ33_EXT0	XUART1_RXD	-
54	XUART2_RXD	I	PD	VDDQ33_EXT0	XUART2_RXD	-
55	XUART2_TXD	I	PD	VDDQ33_EXT0	XUART2_TXD	-
56	XUART3_RXD	I	PD	VDDQ33_EXT0	XUART3_RXD	-
57	XUART3_TXD	I	PD	VDDQ33_EXT0	XUART3_TXD	-

ELECTRICAL SPECIFICATIONS

ABSOLUTE MAXIMUM RATING

Table 11. Absolute Maximum Ratings

PAD Number	Symbol	Condition	Min	Typ	Max	Units
PAD: [32]	V_{IN}	Input voltage V_{IN} on the high efficiency step down converter	-	-	20	V
PAD: [2-19], [21-26], [28-31], [33-45], [48-75]	$V_{undershoot}$	Undershoot voltage for I/O	-0.3	-	-	V
PAD: [31]	PWR_RST	-	-0.3	-	6	V
PAD: [46, 47]	V_{MAX}	Based on 3V3 I/O signalling	-	-	63.3	V
		Continuous	-	-	305	mA
	I_{MAX}	Pulsed	-	-	800	mA

DC ELECTRICAL CHARACTERISTICS

Table 12. I/O DC Electrical Characteristics (PAD: [2-13, 18, 19], [21-26], [28-31], [33-45], [48-75], I/O)

Parameter	Symbol	Condition	Min	Typ	Max	Units	
Tolerant External Voltage	V_{TOL}	3.3 Power Off and On	-	-	3.60	V	
High-Level Input Voltage							
CMOS Interface	V_{IH}		2.31	-	3.60	V	
Low-Level Input Voltage							
CMOS Interface	V_{IL}	$V_{DD}=3.30V$	-0.30	-	0.70	V	
Hysteresis Voltage	ΔV		0.15	-	-	V	
High-Level Input Current							
Input Buffer	I_{IH}	$V_{IN}=3.30V$	$V_{DD}=3.30V$ Power On	-3.00	-	3.00	μA
			$V_{DD}=3.30V$ Power Off & SNS=0	-5.00	-	5.00	μA
Input Buffer with Pull-Down		$V_{IN}=3.30V$		13	40	90	μA
Low-Level Input Current							
Input Buffer	I_{IL}	$V_{IN}=0V$	$V_{DD}=3.30V$ Power On and Off	-3.00	-	3.00	μA
Input Buffer with Pull-Down		$V_{IN}=0V$	$V_{DD}=3.30V$	-13.00	-	-90.00	μA
Output High Voltage	V_{OH}	$I_{OH} = 2.0mA, 4.0mA, 8.0mA$ and $12.0mA$	2.64	-	3.30	V	
Output Low Voltage	V_{OL}	$I_{OL} = -2.0mA, -4.0mA, -8.0mA$ and $-12.0mA$	0	-	0.66	V	
Output Hi-Z Current	V_{OZ}		-5	-	5	μA	
Input Capacitance	C_{IN}	Any input and bi-directional buffers	-	-	5	pF	

Table 13. I/O DC Electrical Characteristics (PAD: [14-17], ADC)

Parameter	Acronym	Condition	Min	Typ	Max	Units
High Level Input Voltage	V_{IH}	Guaranteed Logic High Level	1.26	-	1.80	V
Low Level Input Voltage	V_{IL}	Guaranteed Logic Low Level	0	-	0.54	V
Output High Voltage	V_{OH}	$I_{OH}=2mA, 4mA, 8mA$ and $12mA$	1.44	-	1.80	V
Output Low Voltage	V_{OL}	$I_{OL}=2mA, 4mA, 8mA$ and $12mA$	0	-	0.36	V
Input Pull-Up Resistor Current	I_{RPU}	$V_{PAD}=0$	15	-	77	μA
Input Pull-Down Resistor Current	I_{RPD}	$V_{PAD}=1.80$	17	-	77	μA
Input Hysteresis	V_H	-	0.18	-	-	V
Input Leakage Current for Non Tolerant Cells	I_{PAD}	$D_{VDD}=1.80, V_{PAD}=0$ or $1.80V$	-6	-	+6	μA
Off State Leakage Current	I_{OZ}	$D_{VDD}=1.80, V_{PAD}=0$ or $1.80V$	-6	-	+6	μA

Table 14. Recommended Operating Conditions

Parameter	Symbol	Min	Typ	Max	Units
Main Power Supply: PAD: [32]	DC_5V_12V	4.50	-	18.00	V
Maximum Operating Temperature	T _c	-20	-	85	°C

Table 15. GPIO Signal Drive Strength

State	Currents: Max conditions V _{DD} =3.30V	Units
0	2	mA
1	4	mA
2	8 (Default)	mA
3	12	mA

ESD RATINGS

Table 16. ESD Ratings

Parameter	Min	Typ	Max	Units
ESD stress voltage Human Body Model (JEDEC)	-1.0	-	1.0	kV
ESD stress voltage Charged Device Model	-	250	-	V

AC ELECTRICAL CHARACTERISTICS

Table 17. Level Shifter AC Electrical Characteristics

PAD Number	Symbol	Condition	Min	Typ	Max	Units	
PAD: [46, 47]	Dynamic Characteristics						
	C _{ISS}	Input Capacitance	V _{DS} =25V, f=1.0MHz, V _{GS} =0V	-	-	50	pF
	C _{OSS}	Output Capacitance		-	-	25	pF
	C _{RSS}	Reverse Transfer Capacitance		-	-	5	pF

RF ELECTRICAL CHARACTERISTICS

Table 18. Tx Performance Characteristics

Parameter	Min	Typ	Max	Units
RF frequency range	2412	-	2472	GHz
11b (1-11Mbps)	-	16	-	dBm
11g (6-54Mbps)	-	14	-	dBm
11n, HT20 (MCS0-7)	-	12	-	dBm

Table 19. Rx Performance Characteristics

Parameter	Min	Typ	Max	Units
RF frequency range	2412	-	2472	GHz
11b (1Mbps)	-	-97.2	-	dBm
11b (11Mbps)	-	-89.1	-	dBm
11g (6Mbps)	-	-94.1	-	dBm
11g (54Mbps)	-	-76.2	-	dBm
11n, HT20 (MCS0)	-	-93.9	-	dBm
11n, HT20 (MCS07)	-	-73.8	-	dBm

MECHANICAL SPECIFICATIONS

Figure 4 shows the mechanical dimensions of the ARTIK 053 Module. All dimensions are in mm.

Note: The top layer "NO PCB ROUTING" gray areas are to prevent any shorts between exposed vias or traces and unused ARTIK 053 Module pads.

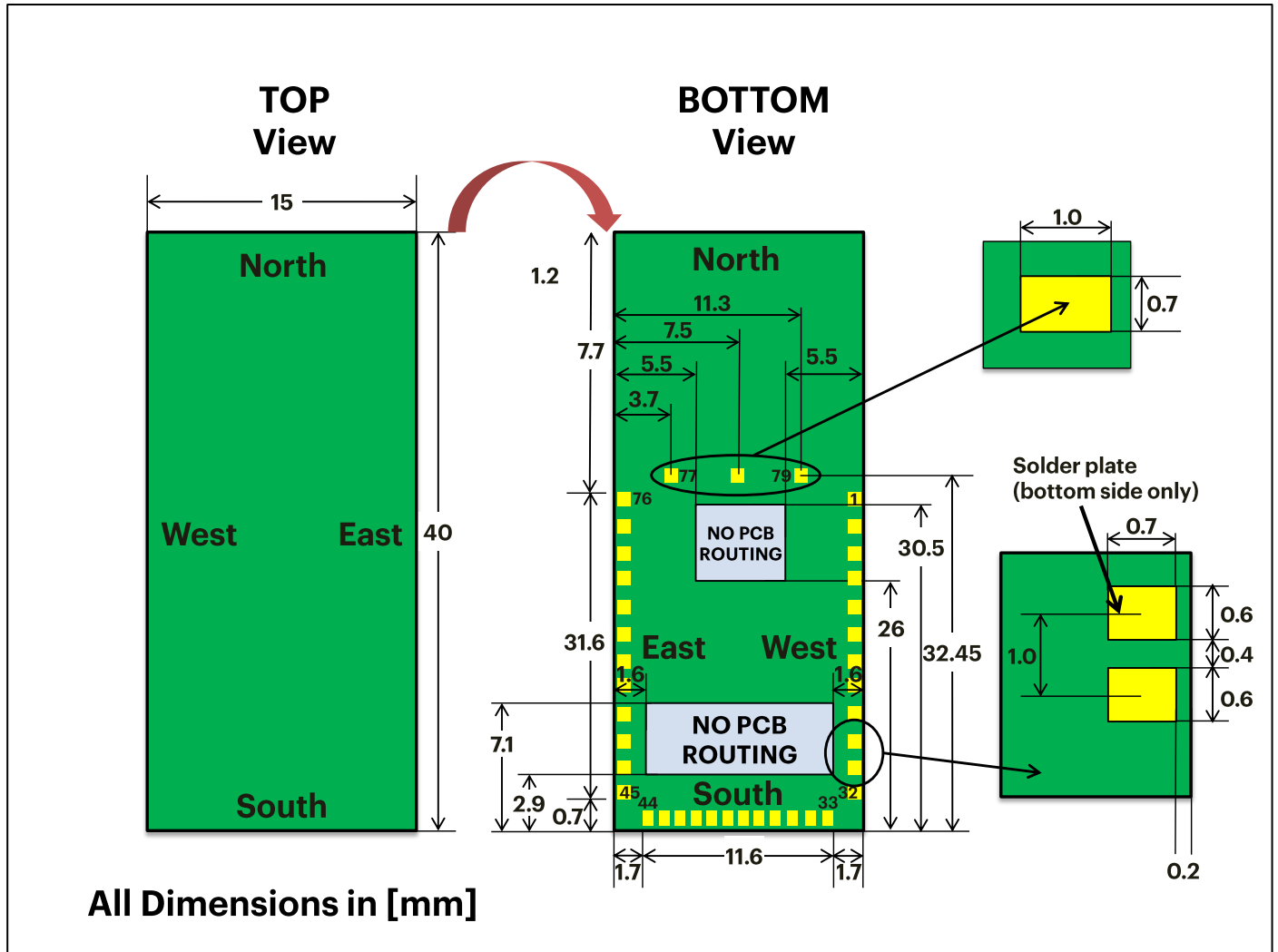

Figure 4. ARTIK 053 Module Mechanical Dimensions

MODULE ANTENNA PLACEMENT REQUIREMENTS

The ARTIK 053 Module has an integrated on-module antenna. [Figure 5](#) describes the precise restrictions on location that must be accounted for when placing the ARTIK 053 Module on your native PCB design. In addition please adhere to the following guidelines:

- Avoid severe WiFi radiation loss by allocating at least a 5x6.7mm “No PCB Routing” area (all layers) on either side of the ARTIK 053 Module, next to the on-module antenna.
- Locate the antenna area at the edge of your PCB board, and as far away from other electronics as possible.
- See [Figure 4](#) for additional routing restrictions.

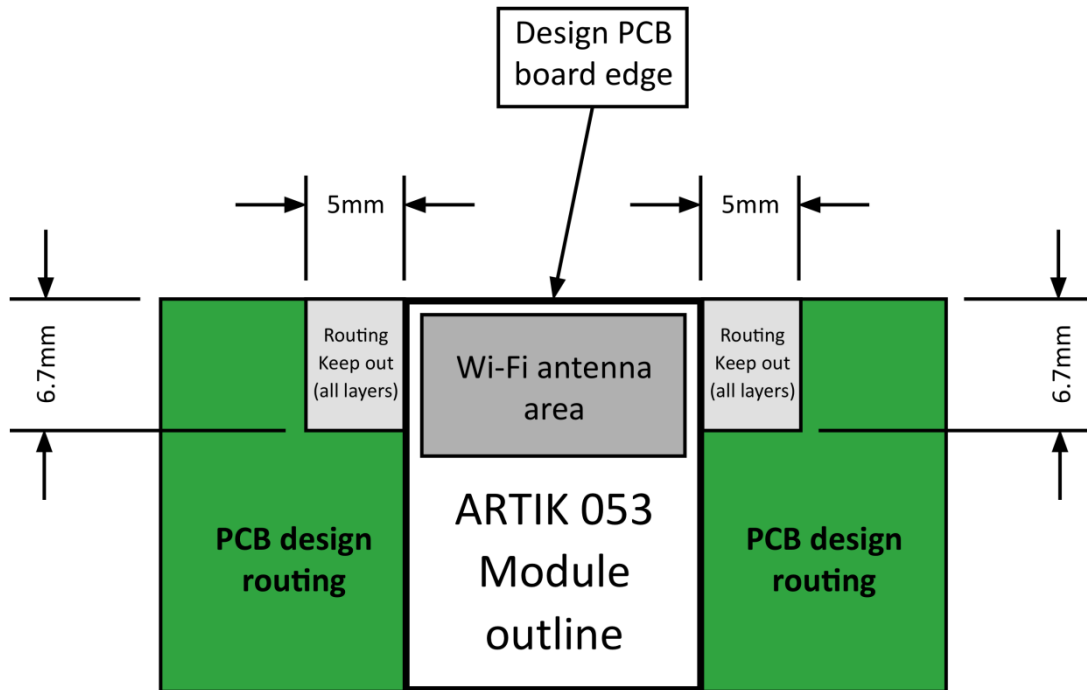

Figure 5. Module Placement Restrictions

CERTIFICATION

FCC REGULATORY DISCLOSURES

This device complies with Part 15 of the FCC`s Rules. Operation is subject to the following two Conditions: (1) This device may not cause harmful interference, and (2) This device must accept any interference received, including interference that may cause undesirable operation.

This equipment has been tested and found to comply with the limits for a Class B digital device, pursuant to part 15 of the FCC Rules. These limits are designed to provide reasonable protection against harmful interference in a residential installation. This equipment generates, uses and can radiate radio frequency energy and, if not installed and used in accordance with the instructions, may cause harmful interference to radio communications. However, there is no guarantee that interference will not occur in a particular installation. If this equipment does cause harmful interference to radio or television reception, which can be determined by turning the equipment off and on, the user is encouraged to try to correct the interference by one or more of the following measures:

- Reorient or relocate the receiving antenna.
- Increase the separation between the equipment and receiver.
- Connect the equipment into an outlet on a circuit different from that to which the receiver is connected.
- Consult the dealer or an experienced radio/ TV technician for help.

This equipment complies with FCC radiation exposure limits set forth for an uncontrolled environment. This equipment should be installed and operated with a minimum distance of 20cm between the transmitter's radiating structure(s) and the body of the user or nearby persons.

This module is intended for OEM integration. The OEM integrator is responsible for FCC compliance and compliance with all applicable regulations including those for modular transmitters 47 C.F.R. 15.212. The OEM product must comply with all applicable labeling requirements including those contained in 15 C.F.R. 15.19. The OEM is solely responsible for certification and testing and labeling of its own products. In addition to any independently required labels, the OEM shall also affix to the outside of a device into which the module is installed a label referring to the enclosed module. This exterior label should be prepared in a legible font and permanently affixed and using the wording "Contains Transmitter Module FCCID: A3LCWAM210S."

The OEM is required to ensure that the end product integrates this module so as to maintain a minimum distance of 20 cm between the equipment's radiating structure(s) and the body of the user or nearby persons. The OEM shall also advise its end user of this requirement as required by applicable rules.

The OEM shall require that the end user of its product be informed that the FCC radio frequency exposure guidelines for an uncontrolled environment can be satisfied. The OEM shall further inform its end user that any change or modifications to this module not expressly approved by the manufacturer will void the warranty and the users' authority to operate the equipment.

INDUSTRY CANADA REGULATORY DISCLOSURES

Industry Canada Statement

This device complies with Industry Canada license-exempt RSS standard(s). Operation is subject to the following two conditions: (1) This device may not cause harmful interference, and (2) this device must accept any interference received, including interference that may cause undesired operation.

Cet appareil est conforme avec Industrie Canada exempts de licence standard RSS (s). L'opération est soumise aux deux conditions suivantes:(1) cet appareil ne peut causer d'interférences, et (2) cet appareil doit accepter toute interférence, y compris les interférences qui peuvent causer un mauvais fonctionnement de l'appareil.

Industry Canada Radiation Exposures Statement and Limitations on Use

This equipment complies with IC RSS-102 radiation exposure limits set forth for an uncontrolled environment. This equipment should be installed and operated with minimum distance 20 cm between the radiator and your body. This equipment should be installed and must not be co-located or operating in conjunction with any other antenna or transmitter.

In the United States and Canada, only Channel 1~11 can be operated and these channel assignments deal only with the 2.4 GHz range.

The end product must be labeled to display the Industry Canada certification number of the module

Contains transmitter module IC: 649E-CWAM210S

Le dispositif d'accueil doivent être étiquetés pour afficher le numéro de certification d'Industrie Canada du module.

Contient module émetteur IC : 649E-CWAM210S

EU REGULATORY DISCLOSURES

CE Statement

The following statement must be supplied with each product but can be printed in the user manual, the packaging, or provided as a separated leaflet.

Hereby, Samsung declares that this IoT Module is in compliance with the essential requirements and other relevant provisions of Article 3 of the R&TTE Directive 1999/5/EC, 2004/108/EC and RoHS directive 2011/65/EU.

“The declaration of conformity may be consulted at www.artik.io/certification”

The OEM is required to ensure that the end product integrates this module so as to maintain a minimum distance of 20 cm between the equipment's radiating structure(s) and the body of the user or nearby persons. The OEM shall also advise its end user of this requirement as required by applicable rules.

ORDERING INFORMATION

Type	Order Number	Description
ARTIK 053 Module	SIP-0P5WRS301	One ARTIK 053 Module

For volume ordering of evaluation kits, please contact a sales representative in your area or visit <https://www.artik.io/contact-us/>.

LEGAL INFORMATION

INFORMATION IN THIS DOCUMENT IS PROVIDED IN CONNECTION WITH THE SAMSUNG ARTIK™ DEVELOPMENT KIT AND ALL RELATED PRODUCTS, UPDATES, AND DOCUMENTATION (HEREINAFTER "SAMSUNG PRODUCTS"). NO LICENSE, EXPRESS OR IMPLIED, BY ESTOPPEL OR OTHERWISE, TO ANY INTELLECTUAL PROPERTY RIGHTS IS GRANTED BY THIS DOCUMENT. THE LICENSE AND OTHER TERMS AND CONDITIONS RELATED TO YOUR USE OF THE SAMSUNG PRODUCTS ARE GOVERNED EXCLUSIVELY BY THE SAMSUNG ARTIK™ DEVELOPER LICENSE AGREEMENT THAT YOU AGREED TO WHEN YOU REGISTERED AS A DEVELOPER TO RECEIVE THE SAMSUNG PRODUCTS. EXCEPT AS PROVIDED IN THE SAMSUNG ARTIK™ DEVELOPER LICENSE AGREEMENT, SAMSUNG ELECTRONICS CO., LTD. AND ITS AFFILIATES (COLLECTIVELY, "SAMSUNG") ASSUMES NO LIABILITY WHATSOEVER, INCLUDING WITHOUT LIMITATION CONSEQUENTIAL OR INCIDENTAL DAMAGES, AND SAMSUNG DISCLAIMS ANY EXPRESS OR IMPLIED WARRANTY, ARISING OUT OF OR RELATED TO YOUR SALE, APPLICATION AND/OR USE OF SAMSUNG PRODUCTS INCLUDING LIABILITY OR WARRANTIES RELATED TO FITNESS FOR A PARTICULAR PURPOSE, MERCHANTABILITY, OR INFRINGEMENT OF ANY PATENT, COPYRIGHT, OR OTHER INTELLECTUAL PROPERTY RIGHT.

SAMSUNG RESERVES THE RIGHT TO CHANGE PRODUCTS, INFORMATION, DOCUMENTATION AND SPECIFICATIONS WITHOUT NOTICE. THIS INCLUDES MAKING CHANGES TO THIS DOCUMENTATION AT ANY TIME WITHOUT PRIOR NOTICE. THIS DOCUMENTATION IS PROVIDED FOR REFERENCE PURPOSES ONLY, AND ALL INFORMATION DISCUSSED HEREIN IS PROVIDED ON AN "AS IS" BASIS, WITHOUT WARRANTIES OF ANY KIND. SAMSUNG ASSUMES NO RESPONSIBILITY FOR POSSIBLE ERRORS OR OMISSIONS, OR FOR ANY CONSEQUENCES FROM THE USE OF THE DOCUMENTATION CONTAINED HEREIN.

Samsung Products are not intended for use in medical, life support, critical care, safety equipment, or similar applications where product failure could result in loss of life or personal or physical harm, or any military or defense application, or any governmental procurement to which special terms or provisions may apply.

This document and all information discussed herein remain the sole and exclusive property of Samsung. All brand names, trademarks and registered trademarks belong to their respective owners. For updates or additional information about Samsung ARTIK™, contact the Samsung ARTIK™ team via the Samsung ARTIK™ website at www.artik.io.

Copyright © 2017 Samsung Electronics Co., Ltd.

All rights reserved. No part of this publication may be reproduced, stored in a retrieval system, or transmitted in any form or by any means, electric or mechanical, by photocopying, recording, or otherwise, without the prior written consent of Samsung Electronics.

SAMSUNG ELECTRONICS RESERVES THE RIGHT TO CHANGE PRODUCTS, INFORMATION AND SPECIFICATIONS WITHOUT NOTICE. Products and specifications discussed herein are for reference purposes only. All information discussed herein is provided on an "AS IS" basis, without warranties of any kind. This document and all information discussed herein remain the sole and exclusive property of Samsung Electronics. No license of any patent, copyright, mask work, trademark or any other intellectual property right is granted by one party to the other party under this document, by implication, estoppel or other-wise. Samsung products are not intended for use in life support, critical care, medical, safety equipment, or similar applications where product failure could result in loss of life or personal or physical harm, or any military or defense application, or any governmental procurement to which special terms or provisions may apply. For updates or additional information about Samsung products, contact your nearest Samsung office. All brand names, trademarks and registered trademarks belong to their respective owners.

Looking for pricing, stock, or lifecycle information?

Click below to explore more details on WIN SOURCE:

 [View SIP-0P5WRS301 on WIN SOURCE](#)

 [Samsung Information](#)

Optimize Your Supply Chain with WIN SOURCE Solutions

-  Global Sourcing Solution
-  Obsolete Management
-  Cost Control Management
-  Shortage Management
-  Alternative Solution
-  Excess Inventory Management