



**THE DATASHEET OF
ACS70331EESATR-2P5B3**



TLV3544-Q1 250-MHz, Rail-to-Rail I/O, CMOS Operational Amplifier for Automotive

1 Features

- Qualified for Automotive Applications
- AEC-Q100 Qualified With the Following Results:
 - Device Temperature Grade 1: T_A -40°C to $+125^{\circ}\text{C}$ Ambient Operating Temperature Range
 - Device HBM ESD Classification Level 1C
 - Device CDM ESD Classification Level C3
- Unity-Gain Bandwidth: 250 MHz
- Wide Bandwidth: 100-MHz GBW
- High Slew Rate: 150 V/ μs
- Low Noise: 7.5 nV/ $\sqrt{\text{Hz}}$
- Rail-to-Rail I/O
- High Output Current: > 100 mA
- Excellent Video Performance:
 - Differential Gain: 0.02%, Differential Phase: 0.09°
 - 0.1-dB Gain Flatness: 40 MHz
- Low Input Bias Current: 3 pA
- Quiescent Current: 5.2 mA
- Thermal Shutdown
- Supply Range: 2.5 V to 5.5 V

Simplified Diagram

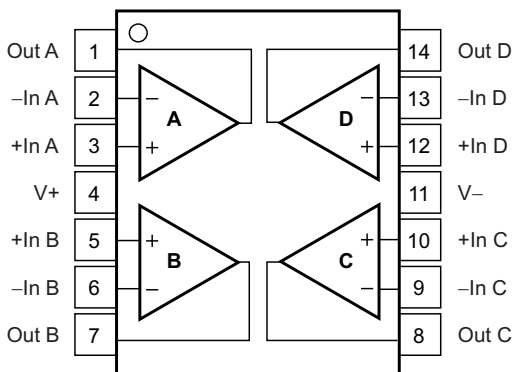

2 Applications

- Current Sense Amplifiers
- Inverter and Motor Control
- Engine Management
- Battery Management
- Navigation and Radio System
- Urea Level and Concentration Sensor
- Blind-Spot Detection
- Short-to-Mid Range Radar
- Surround View and Backup Camera Video Processing
- Automotive SAR ADC driver for Powertrain Sensor systems

3 Description

The TLV3544-Q1 series of high-speed, voltage-feedback CMOS operational amplifiers (op amps) are designed for video and other applications requiring wide bandwidth. They are unity-gain stable and can drive large output currents. Differential gain is 0.02% and differential phase is 0.09°. Quiescent current is only 4.9 mA per channel.

The TLV3544-Q1 quad-channel op amp is optimized for operation on single or dual supplies as low as 2.5 V (± 1.25 V) and up to 5.5 V (± 2.75 V). Common-mode input range extends beyond the supplies. The output swing is within 100 mV of the rails, supporting wide dynamic range.

Multichannel version feature completely independent circuitry for lowest crosstalk and freedom from interaction. All are specified over the extended -40°C to $+125^{\circ}\text{C}$ temperature range.

Device Information⁽¹⁾

PART NUMBER	PACKAGE	BODY SIZE (NOM)
TLV3544-Q1	TSSOP (14)	5.00 mm x 4.40 mm

(1) For all available packages, see the orderable addendum at the end of the data sheet.



Table of Contents

1 Features	1	8 Application and Implementation	19
2 Applications	1	8.1 Application Information.....	19
3 Description	1	8.2 Typical Application	19
4 Revision History	2	9 Power Supply Recommendations	21
5 Pin Configuration and Functions	3	10 Layout	21
6 Specifications	4	10.1 Layout Guidelines	21
6.1 Absolute Maximum Ratings	4	10.2 Layout Example	21
6.2 ESD Ratings.....	4	10.3 Power Dissipation	21
6.3 Recommended Operating Conditions.....	4	11 Device and Documentation Support	23
6.4 Thermal Information: TLV3544-Q1	4	11.1 Documentation Support	23
6.5 Electrical Characteristics: $V_S = 2.7\text{ V to }5.5\text{ V Single-Supply}$	5	11.2 Receiving Notification of Documentation Updates	23
6.6 Typical Characteristics.....	7	11.3 Community Resources.....	23
7 Detailed Description	12	11.4 Trademarks	23
7.1 Overview	12	11.5 Electrostatic Discharge Caution.....	23
7.2 Functional Block Diagram	12	11.6 Glossary	23
7.3 Feature Description.....	13	12 Mechanical, Packaging, and Orderable Information	23
7.4 Device Functional Modes.....	18		

4 Revision History

NOTE: Page numbers for previous revisions may differ from page numbers in the current version.

DATE	REVISION	NOTES
October 2017	*	Initial release.

5 Pin Configuration and Functions

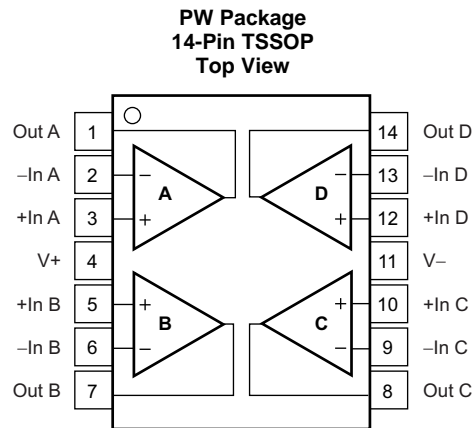

Pin Functions

PIN		I/O	DESCRIPTION
NAME	NO.		
-In A	2	I	Inverting input, channel A
+In A	3	I	Noninverting input, channel A
-In B	6	I	Inverting input, channel B
+In B	5	I	Noninverting input, channel B
-In C	9	I	Inverting input, channel C
+In C	10	I	Noninverting input, channel C
-In D	13	I	Inverting input, channel D
+In D	12	I	Noninverting input, channel D
Out A	1	O	Output, channel A
Out B	7	O	Output, channel B
Out C	8	O	Output, channel C
Out D	14	O	Output, channel D
V-	11	—	Negative (lowest) supply
V+	4	—	Positive (highest) supply

6 Specifications

6.1 Absolute Maximum Ratings

over operating free-air temperature range (unless otherwise noted)⁽¹⁾

		MIN	MAX	UNIT
Voltage	Supply voltage, V+ to V–	7.5		V
	Signal input terminals ⁽²⁾	(V–) – (0.5)	(V+) + 0.5	
Current	Signal input terminals ⁽²⁾	–10	10	mA
	Output short circuit ⁽³⁾	Continuous		
Temperature	Operating, T _A	–55	150	°C
	Junction, T _J	150		
	Storage, T _{stg}	–65	150	

- (1) Stresses beyond those listed under *Absolute Maximum Ratings* may cause permanent damage to the device. These are stress ratings only, which do not imply functional operation of the device at these or any other conditions beyond those indicated under *Recommended Operating Conditions*. Exposure to absolute-maximum-rated conditions for extended periods may affect device reliability.
- (2) Input pins are diode-clamped to the power-supply rails. Input signals that can swing more than 0.5 V beyond the supply rails must be current limited to 10 mA or less.
- (3) Short-circuit to ground, one amplifier per package.

6.2 ESD Ratings

		VALUE	UNIT
V _(ESD) Electrostatic discharge	Human-body model (HBM), per AEC Q100-002 ⁽¹⁾	±1000	V
	Charged-device model (CDM), per AEC Q100-011	±250	

- (1) AEC Q100-002 indicates that HBM stressing shall be in accordance with the ANSI/ESDA/JEDEC JS-001 specification.

6.3 Recommended Operating Conditions

over operating free-air temperature range (unless otherwise noted)

		MIN	MAX	UNIT
V _S	Supply voltage, V– to V+	2.5	5.5	V
Specified temperature		–40	125	°C

6.4 Thermal Information: TLV3544-Q1

THERMAL METRIC		TLV3544-Q1	UNIT
		PW (TSSOP)	
		14 PINS	
R _{θJA}	Junction-to-ambient thermal resistance	92.6	°C/W
R _{θJC(top)}	Junction-to-case (top) thermal resistance	27.5	°C/W
R _{θJB}	Junction-to-board thermal resistance	33.6	°C/W
Ψ _{JT}	Junction-to-top characterization parameter	1.9	°C/W
Ψ _{JB}	Junction-to-board characterization parameter	33.1	°C/W
R _{θJC(bot)}	Junction-to-case (bottom) thermal resistance	—	°C/W

6.5 Electrical Characteristics: $V_S = 2.7\text{ V to }5.5\text{ V}$ Single-Supply

At $T_A = 25^\circ\text{C}$, $R_F = 0\ \Omega$, $R_L = 1\ \text{k}\Omega$, and connected to $V_S/2$, unless otherwise noted.

PARAMETER		TEST CONDITIONS	MIN	TYP	MAX	UNIT
OFFSET VOLTAGE						
V_{OS}	Input offset voltage	$V_S = 5\text{ V}$, at $T_A = 25^\circ\text{C}$		± 2	± 10	mV
dV_{OS}/dT	Input offset voltage vs temperature	$V_S = 5\text{ V}$, at $T_A = -40^\circ\text{C to }+125^\circ\text{C}$		± 4.5		$\mu\text{V}/^\circ\text{C}$
$PSRR$	Input offset voltage vs power supply	$V_S = 2.7\text{ V to }5.5\text{ V}$, $V_{CM} = (V_S/2) - 0.55\text{ V}$		± 200	± 800	$\mu\text{V}/\text{V}$
		$V_S = 2.7\text{ V to }5.5\text{ V}$, $V_{CM} = (V_S/2) - 0.55\text{ V}$, at $T_A = -40^\circ\text{C to }+125^\circ\text{C}$			± 900	
INPUT BIAS CURRENT						
I_B	Input bias current			3		pA
I_{OS}	Input offset current			± 1		pA
NOISE						
e_n	Input voltage noise density	$f = 1\text{ MHz}$		7.5		$\text{nV}/\sqrt{\text{Hz}}$
i_n	Current noise density	$f = 1\text{ MHz}$		50		$\text{fA}/\sqrt{\text{Hz}}$
INPUT VOLTAGE RANGE						
V_{CM}	Common-mode voltage		$(V-) - 0.1$		$(V+) + 0.1$	V
$CMRR$	Common-mode rejection ratio	$V_S = 5.5\text{ V}$, $-0.1\text{ V} < V_{CM} < 3.5\text{ V}$, at $T_A = 25^\circ\text{C}$	66	80		dB
		$V_S = 5.5\text{ V}$, $-0.1\text{ V} < V_{CM} < 5.6\text{ V}$, at $T_A = 25^\circ\text{C}$	56	68		
INPUT IMPEDANCE						
	Differential			$10^{13} \parallel 2$		$\Omega \parallel \text{pF}$
	Common-mode			$10^{13} \parallel 2$		$\Omega \parallel \text{pF}$
OPEN-LOOP GAIN						
A_{OL}	Open-loop gain	$V_S = 5.5\text{ V}$, $0.3\text{ V} < V_O < 4.7\text{ V}$, at $T_A = 25^\circ\text{C}$	94	110		dB
		$V_S = 5\text{ V}$, $0.4\text{ V} < V_O < 4.6\text{ V}$, at $T_A = -40^\circ\text{C to }+125^\circ\text{C}$	90			
FREQUENCY RESPONSE						
$f_{-3\text{dB}}$	Small-signal bandwidth	At $G = +1$, $V_O = 100\text{ mV}_{PP}$, $R_F = 25\ \Omega$		250		MHz
		At $G = +2$, $V_O = 100\text{ mV}_{PP}$		90		
GBW	Gain-bandwidth product	$G = +10$		100		MHz
$f_{0.1\text{dB}}$	Bandwidth for 0.1-dB gain flatness	At $G = +2$, $V_O = 100\text{ mV}_{PP}$		40		MHz
SR	Slew rate	$V_S = 5\text{ V}$, $G = +1$, 4-V step		150		$\text{V}/\mu\text{s}$
		$V_S = 5\text{ V}$, $G = +1$, 2-V step		130		
		$V_S = 3\text{ V}$, $G = +1$, 2-V step		110		
	Rise-and-fall time	At $G = +1$, $V_O = 200\text{ mV}_{PP}$, 10% to 90%		2		ns
		At $G = +1$, $V_O = 2\text{ V}_{PP}$, 10% to 90%		11		
	Settling time	0.1%, $V_S = 5\text{ V}$, $G = +1$, 2-V output step		30		ns
		0.01%, $V_S = 5\text{ V}$, $G = +1$, 2-V output step		60		
	Overload recovery time	$V_{IN} \times \text{Gain} = V_S$		5		ns

Electrical Characteristics: $V_S = 2.7\text{ V to }5.5\text{ V}$ Single-Supply (continued)

 At $T_A = 25^\circ\text{C}$, $R_F = 0\ \Omega$, $R_L = 1\ \text{k}\Omega$, and connected to $V_S/2$, unless otherwise noted.

PARAMETER		TEST CONDITIONS	MIN	TYP	MAX	UNIT
FREQUENCY RESPONSE, continued						
Harmonic distortion	Second harmonic	At $G = +1$, $f = 1\ \text{MHz}$, $V_O = 2\ V_{PP}$, $R_L = 200\ \Omega$, $V_{CM} = 1.5\ \text{V}$		-75		dBc
	Third harmonic	At $G = +1$, $f = 1\ \text{MHz}$, $V_O = 2\ V_{PP}$, $R_L = 200\ \Omega$, $V_{CM} = 1.5\ \text{V}$		-83		
Differential gain error		NTSC, $R_L = 150\ \Omega$		0.02%		
Differential phase error		NTSC, $R_L = 150\ \Omega$		0.09		°
Channel-to-channel crosstalk	TLV3544-Q1	$f = 5\ \text{MHz}$		-84		dB
OUTPUT						
Voltage output swing from rail		$V_S = 5\ \text{V}$, $R_L = 1\ \text{k}\Omega$, $A_{OL} > 94\ \text{dB}$, at $T_A = 25^\circ\text{C}$		0.1	0.3	V
I_O	Output current ⁽¹⁾⁽²⁾	$V_S = 5\ \text{V}$	100			mA
		$V_S = 3\ \text{V}$		50		mA
Closed-loop output impedance		$f < 100\ \text{kHz}$		0.05		Ω
R_O	Open-loop output resistance			35		Ω
POWER SUPPLY						
V_S	Specified voltage		2.7		5	V
	Operating voltage		2.5		5.5	
I_Q	Quiescent current (per amplifier)	At $T_A = 25^\circ\text{C}$, $V_S = 5\ \text{V}$, enabled, $I_O = 0$		5.2	6.5	mA
THERMAL SHUTDOWN – JUNCTION TEMPERATURE						
Shutdown				160		°C
Reset from shutdown				140		°C
THERMAL RANGE						
Specified			-40		125	°C
Operating			-55		150	°C
Storage			-65		150	°C

 (1) See typical characteristic curves, *Output Voltage Swing vs Output Current* (Figure 20 and Figure 22).

(2) Specified by design.

6.6 Typical Characteristics

At $T_A = 25^\circ\text{C}$, $V_S = 5\text{ V}$, $G = +1$, $R_F = 0\ \Omega$, $R_L = 1\ \text{k}\Omega$, and connected to $V_S/2$, unless otherwise noted.

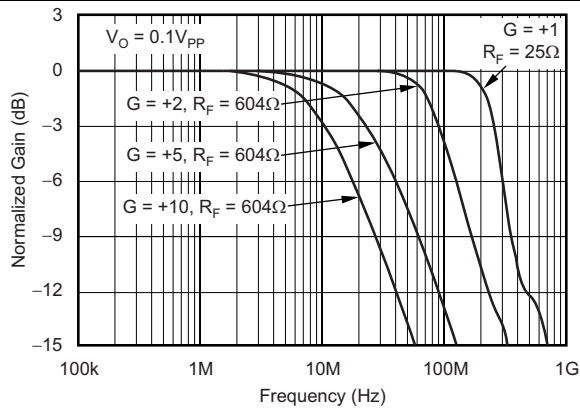

Figure 1. Noninverting Small-Signal Frequency Response

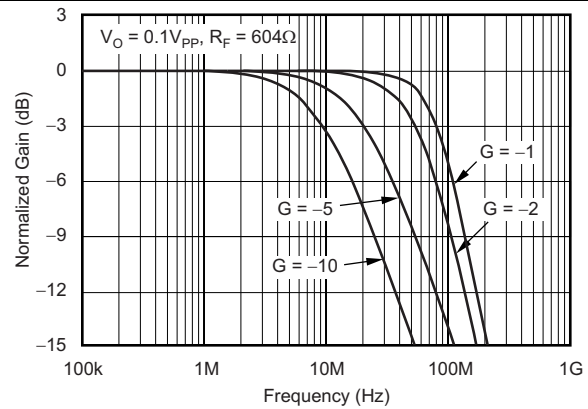

Figure 2. Inverting Small-Signal Frequency Response

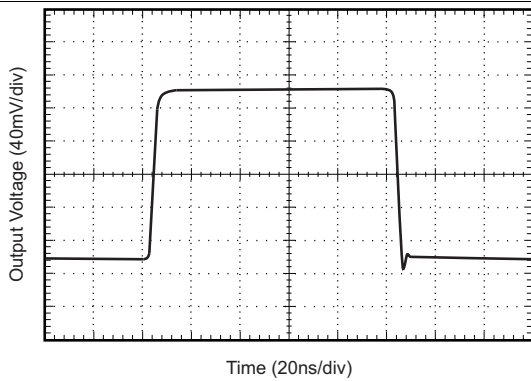

Figure 3. Noninverting Small-Signal Step Response

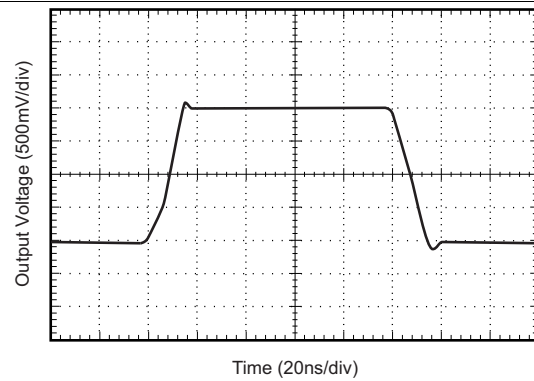

Figure 4. Noninverting Large-Signal Step Response

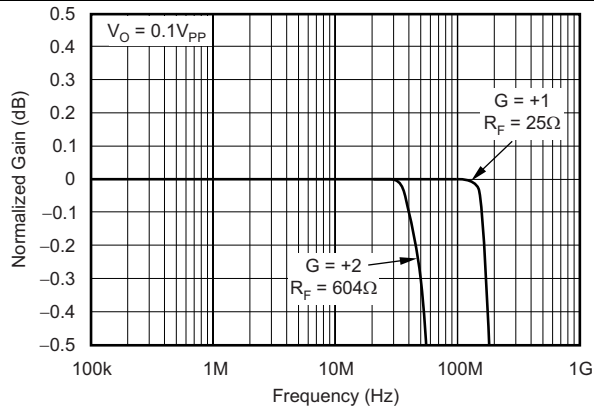

Figure 5. 0.1-dB Gain Flatness

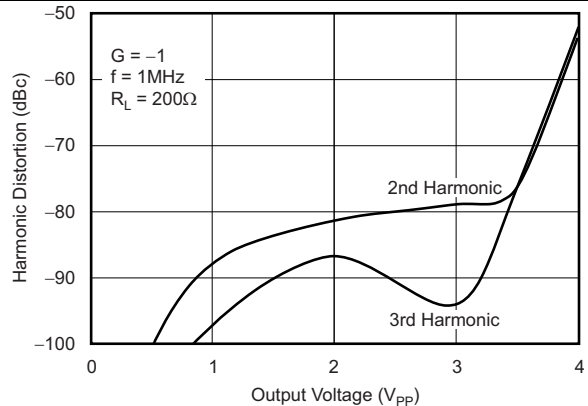
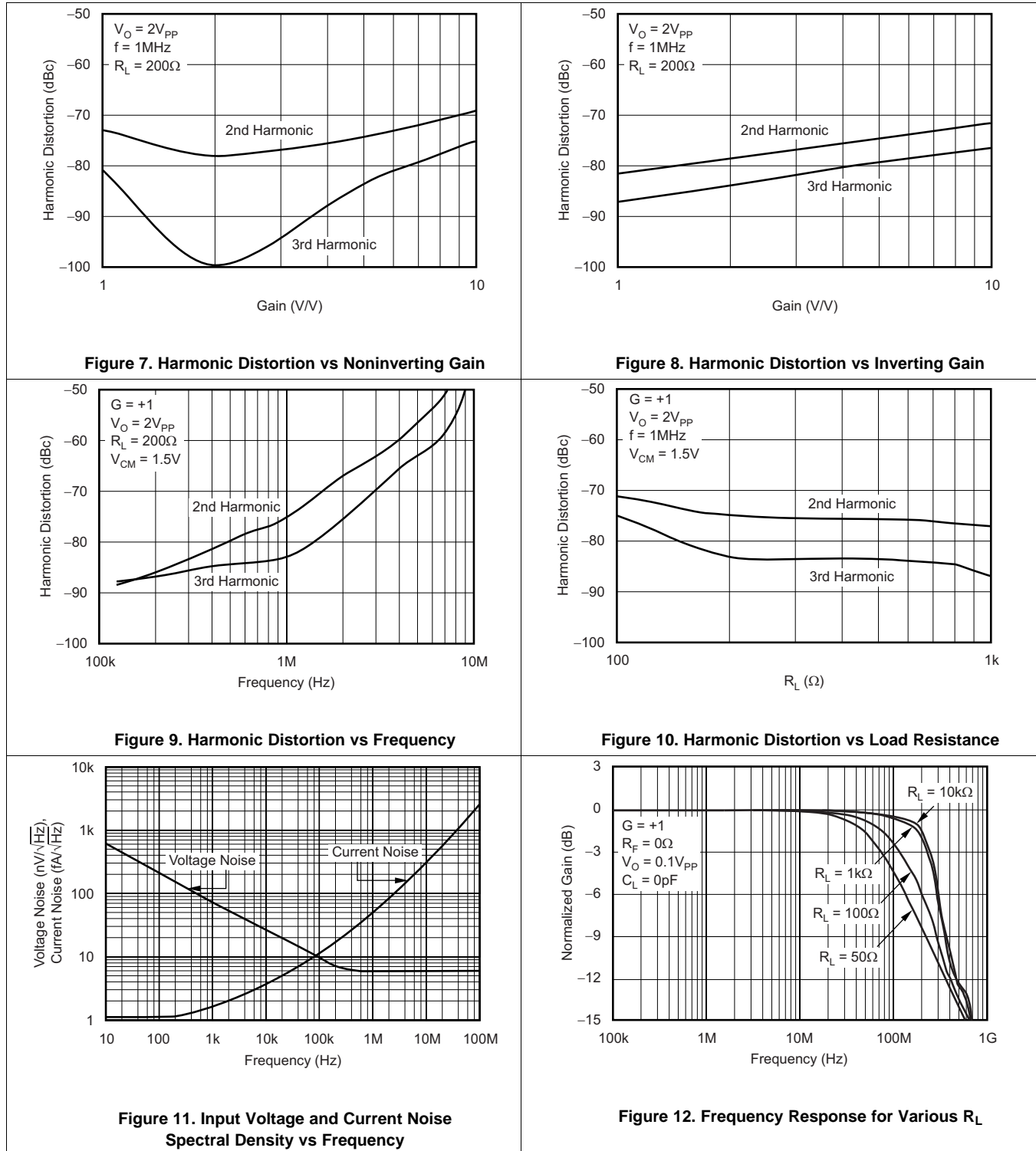

Figure 6. Harmonic Distortion vs Output Voltage

Typical Characteristics (continued)

At $T_A = 25^\circ\text{C}$, $V_S = 5\text{ V}$, $G = +1$, $R_F = 0\ \Omega$, $R_L = 1\ \text{k}\Omega$, and connected to $V_S/2$, unless otherwise noted.



Typical Characteristics (continued)

At $T_A = 25^\circ\text{C}$, $V_S = 5\text{ V}$, $G = +1$, $R_F = 0\ \Omega$, $R_L = 1\ \text{k}\Omega$, and connected to $V_S/2$, unless otherwise noted.

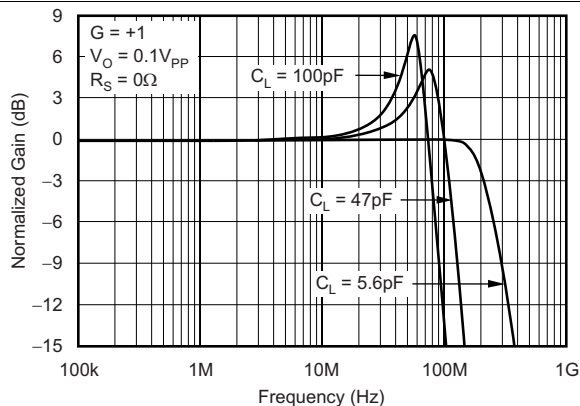

Figure 13. Frequency Response for Various C_L

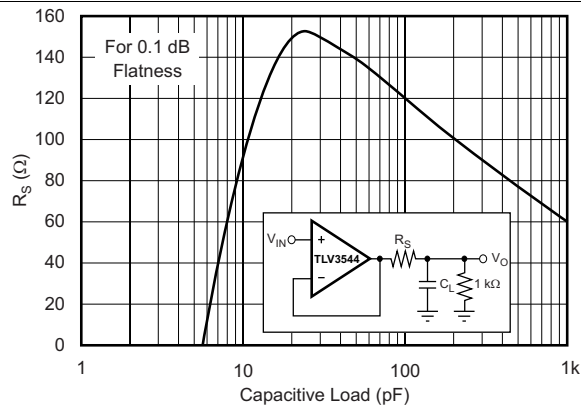

Figure 14. Recommended R_S vs Capacitive Load

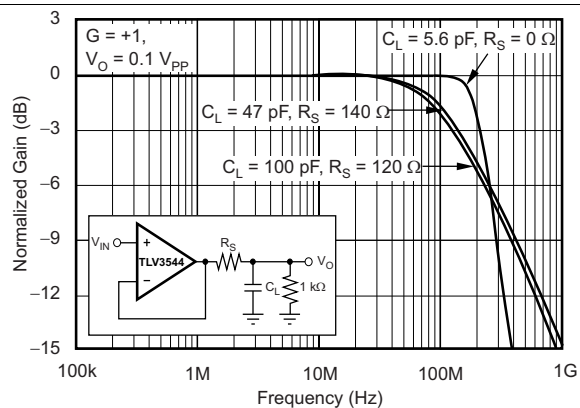

Figure 15. Frequency Response vs Capacitive Load

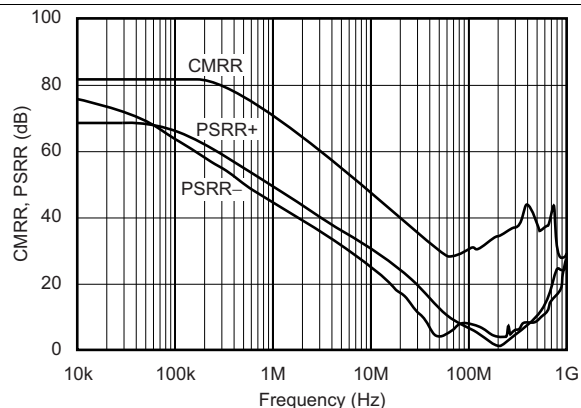

Figure 16. Common-Mode Rejection Ratio and Power-Supply Rejection Ratio vs Frequency

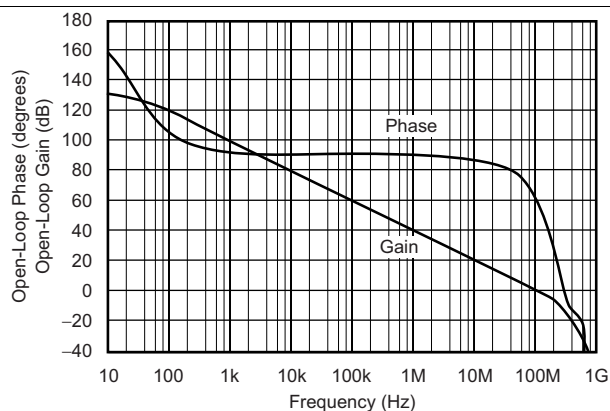

Figure 17. Open-Loop Gain and Phase

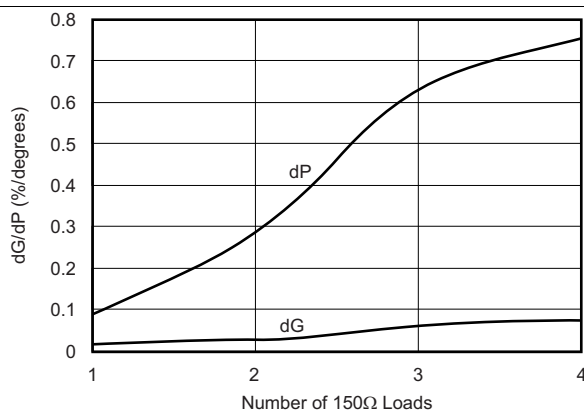
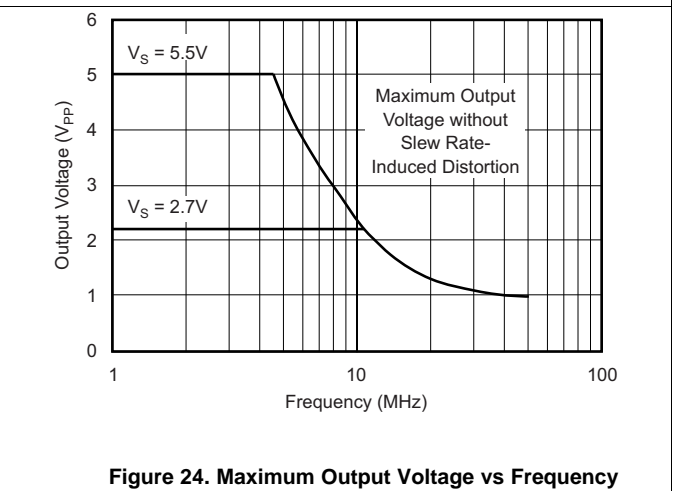
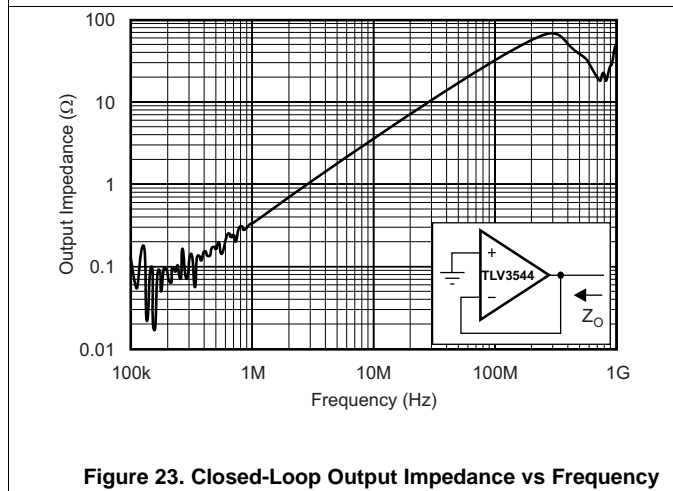
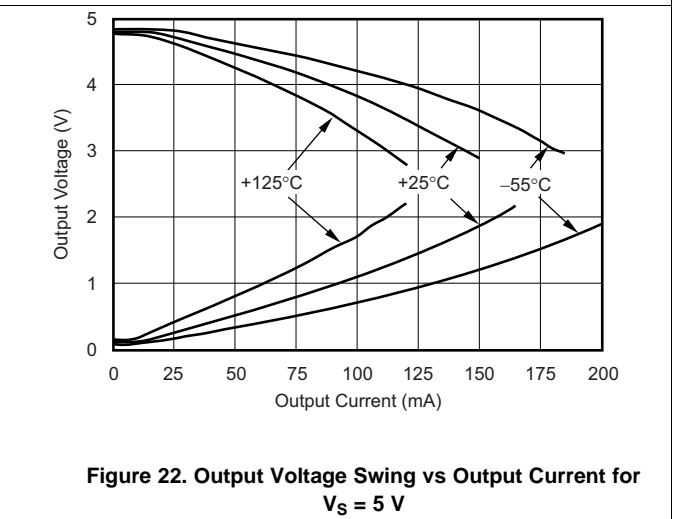
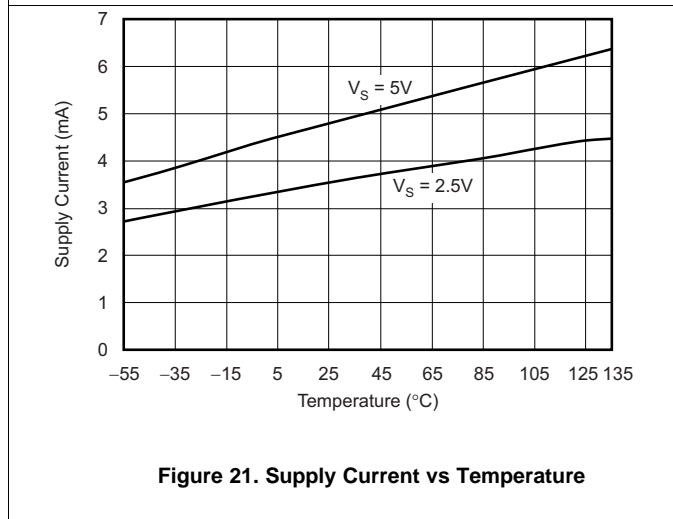
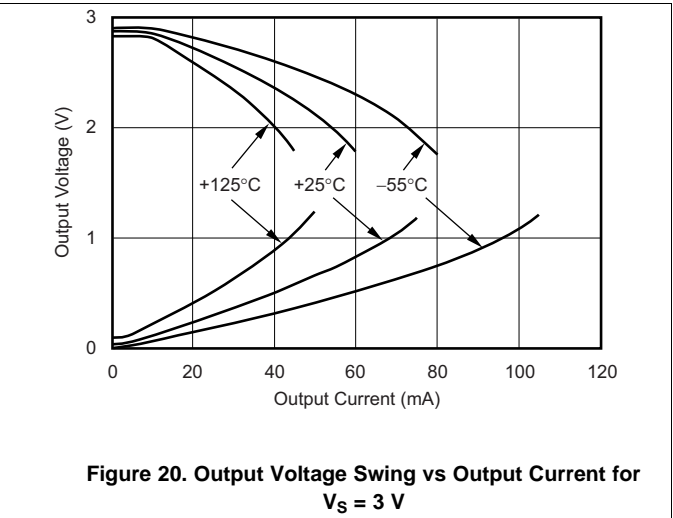
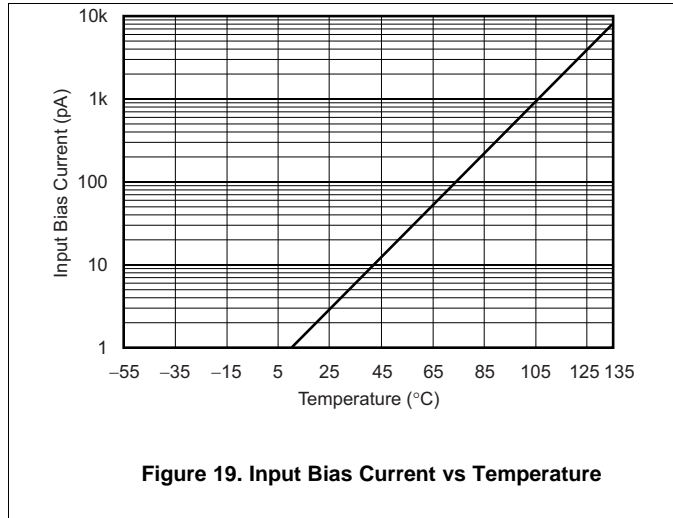

Figure 18. Composite Video Differential Gain and Phase

Typical Characteristics (continued)

At $T_A = 25^\circ\text{C}$, $V_S = 5\text{ V}$, $G = +1$, $R_F = 0\ \Omega$, $R_L = 1\ \text{k}\Omega$, and connected to $V_S/2$, unless otherwise noted.



Typical Characteristics (continued)

At $T_A = 25^\circ\text{C}$, $V_S = 5\text{ V}$, $G = +1$, $R_F = 0\ \Omega$, $R_L = 1\ \text{k}\Omega$, and connected to $V_S/2$, unless otherwise noted.

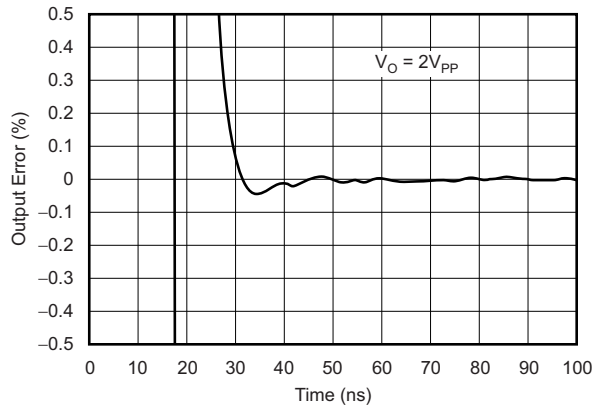

Figure 25. Output Settling Time to 0.1%

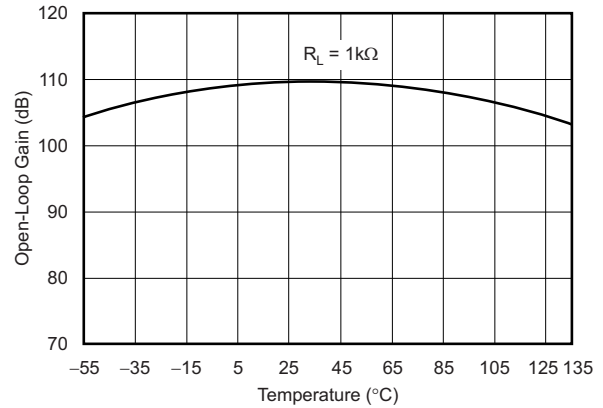

Figure 26. Open-Loop Gain vs Temperature

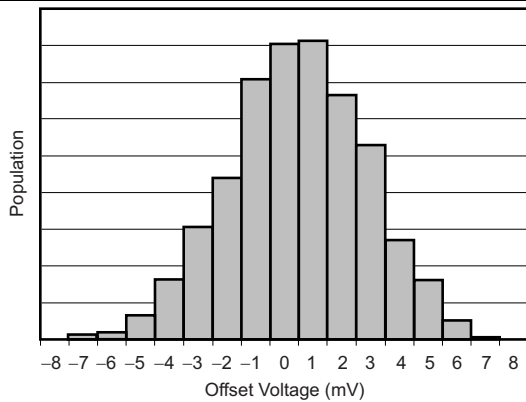

Figure 27. Offset Voltage Production Distribution

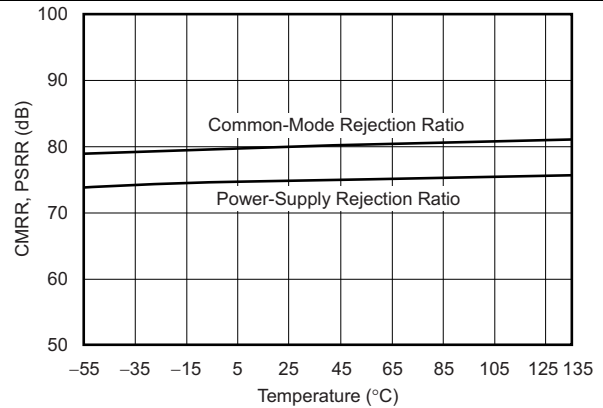

Figure 28. Common-Mode Rejection Ratio and Power-Supply Rejection Ratio vs Temperature

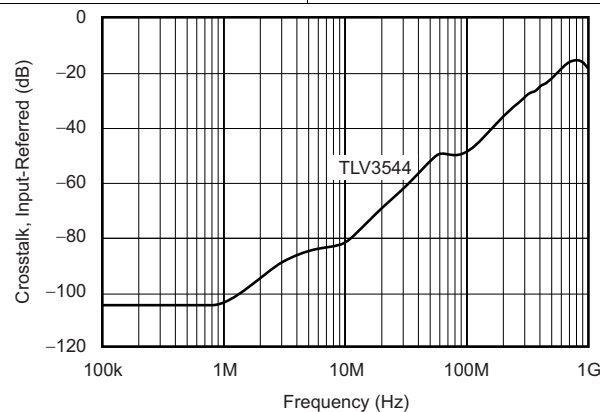

Figure 29. Channel-to-Channel Crosstalk

7 Detailed Description

7.1 Overview

The TLV3544-Q1 is a quad-channel CMOS, rail-to-rail I/O, high-speed, voltage-feedback operational amplifier designed for video, high-speed, and other applications.

The amplifier features a 100-MHz gain bandwidth and 150-V/ μ s slew rate, but it is unity-gain stable and can be operated as a +1-V/V voltage follower.

7.2 Functional Block Diagram

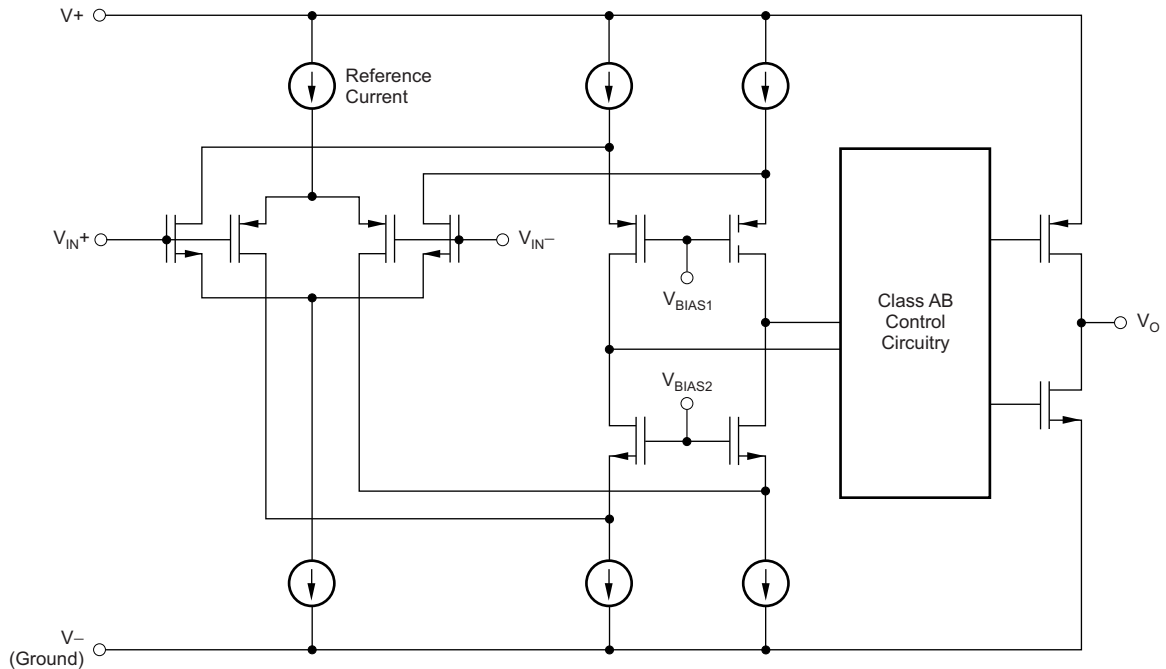

Copyright © 2017, Texas Instruments Incorporated

7.3 Feature Description

7.3.1 TLV3544-Q1 Comparison

Table 1 lists several members of the device family that includes the TLV3544-Q1.

Table 1. Device Family Comparison

FEATURES	PRODUCT
Shutdown Version of TLV3544 Family	OPAx357
200-MHz GBW, Rail-to-Rail Output, CMOS, Shutdown	OPAx355
200-MHz GBW, Rail-to-Rail Output, CMOS	OPAx356
38-MHz GBW, Rail-to-Rail Input/Output, CMOS	OPAx350/OPAx353
75-MHz BW $G = 2$, Rail-to-Rail Output	OPA2631
150-MHz BW $G = 2$, Rail-to-Rail Output	OPA2634
100-MHz BW, Differential Input/Output, 3.3-V Supply	THS412x

7.3.2 Operating Voltage

The TLV3544-Q1 is specified over a power-supply range of 2.7 V to 5.5 V (± 1.35 V to ± 2.75 V). However, the supply voltage may range from 2.5 V to 5.5 V (± 1.25 V to ± 2.75 V).

CAUTION

Supply voltages higher than 7.5 V (absolute maximum) can permanently damage the amplifier.

Parameters that vary over supply voltage or temperature are shown in *Typical Characteristics* of this data sheet.

7.3.3 Rail-to-Rail Input

The specified input common-mode voltage range of the TLV3544-Q1 extends 100 mV beyond the supply rails. This extended range is achieved with a complementary input stage—an N-channel input differential pair in parallel with a P-channel differential pair, as shown in the *Functional Block Diagram*. The N-channel pair is active for input voltages close to the positive rail, typically $(V+) - 1.2$ V to 100 mV above the positive supply, while the P-channel pair is on for inputs from 100 mV below the negative supply to approximately $(V+) - 1.2$ V. There is a small transition region, typically $(V+) - 1.5$ V to $(V+) - 0.9$ V, in which both pairs are on. This 600-mV transition region can vary ± 500 mV with process variation. Thus, the transition region (both input stages on) can range from $(V+) - 2$ V to $(V+) - 1.5$ V on the low end, up to $(V+) - 0.9$ V to $(V+) - 0.4$ V on the high end.

A double-folded cascode adds the signal from the two input pairs and presents a differential signal to the class AB output stage.

7.3.4 Rail-to-Rail Output

A class AB output stage with common-source transistors is used to achieve rail-to-rail output. For high-impedance loads ($> 200 \Omega$), the output voltage swing is typically 100 mV from the supply rails. With 10- Ω loads, a useful output swing can be achieved while maintaining high open-loop gain. See the typical characteristic curves, *Output Voltage Swing vs Output Current* (Figure 20 and Figure 22).

7.3.5 Output Drive

The TLV3544-Q1 output stage can supply a continuous output current of ± 100 mA and yet provide approximately 2.7 V of output swing on a 5-V supply, as shown in Figure 30. For maximum reliability, TI does not recommend running a continuous DC current in excess of ± 100 mA. Refer to the typical characteristic curves, *Output Voltage Swing vs Output Current* (Figure 20 and Figure 22). For supplying continuous output currents greater than ± 100 mA, the TLV3544-Q1 may be operated in parallel, as shown in Figure 31.

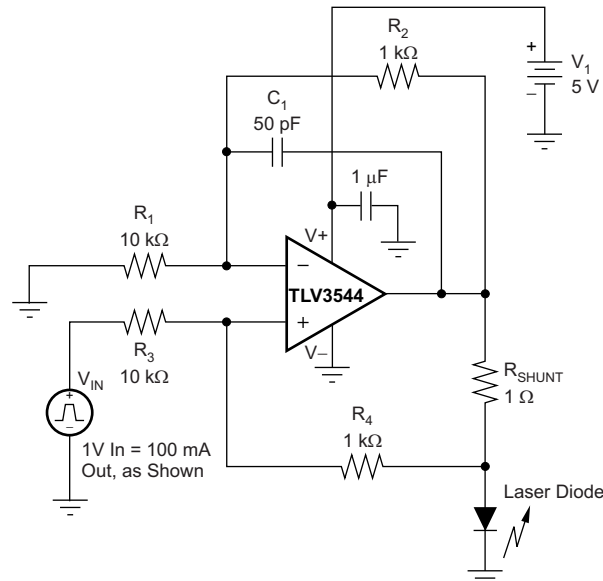

Copyright © 2017, Texas Instruments Incorporated

Figure 30. Laser Diode Driver

The TLV3544-Q1 provides peak currents up to 200 mA, which corresponds to the typical short-circuit current. Therefore, an on-chip thermal shutdown circuit is provided to protect the TLV3544-Q1 from dangerously high junction temperatures. At 160°C, the protection circuit shuts down the amplifier. Normal operation resumes when the junction temperature cools to below 140°C.

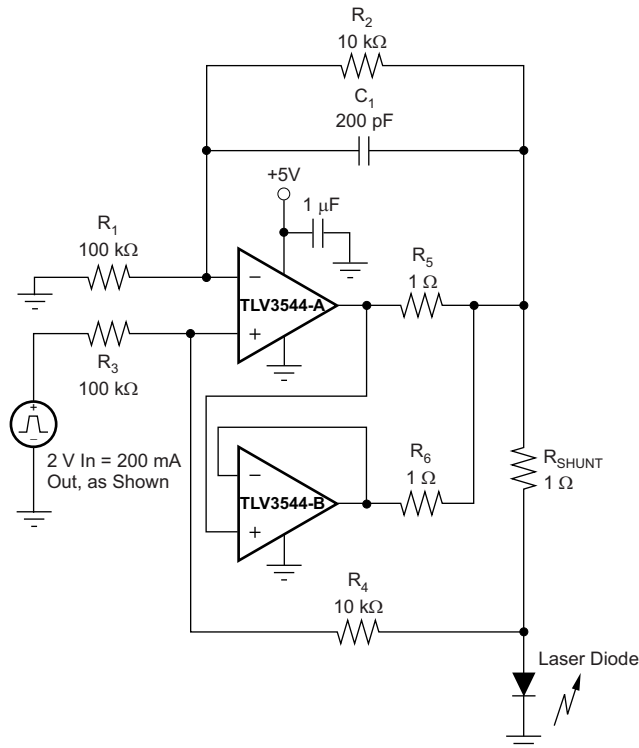

Copyright © 2017, Texas Instruments Incorporated

Figure 31. Parallel Operation

7.3.6 Video

The TLV3544-Q1 output stage is capable of driving standard back-terminated 75-Ω video cables, as shown in [Figure 32](#). By back-terminating a transmission line, it does not exhibit a capacitive load to its driver. A properly back-terminated 75-Ω cable does not appear as capacitance; it presents only a 150-Ω resistive load to the TLV3544-Q1 output.

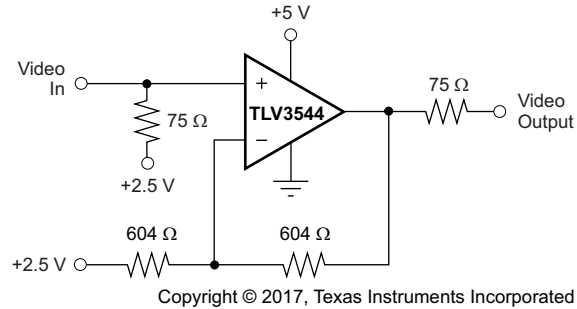
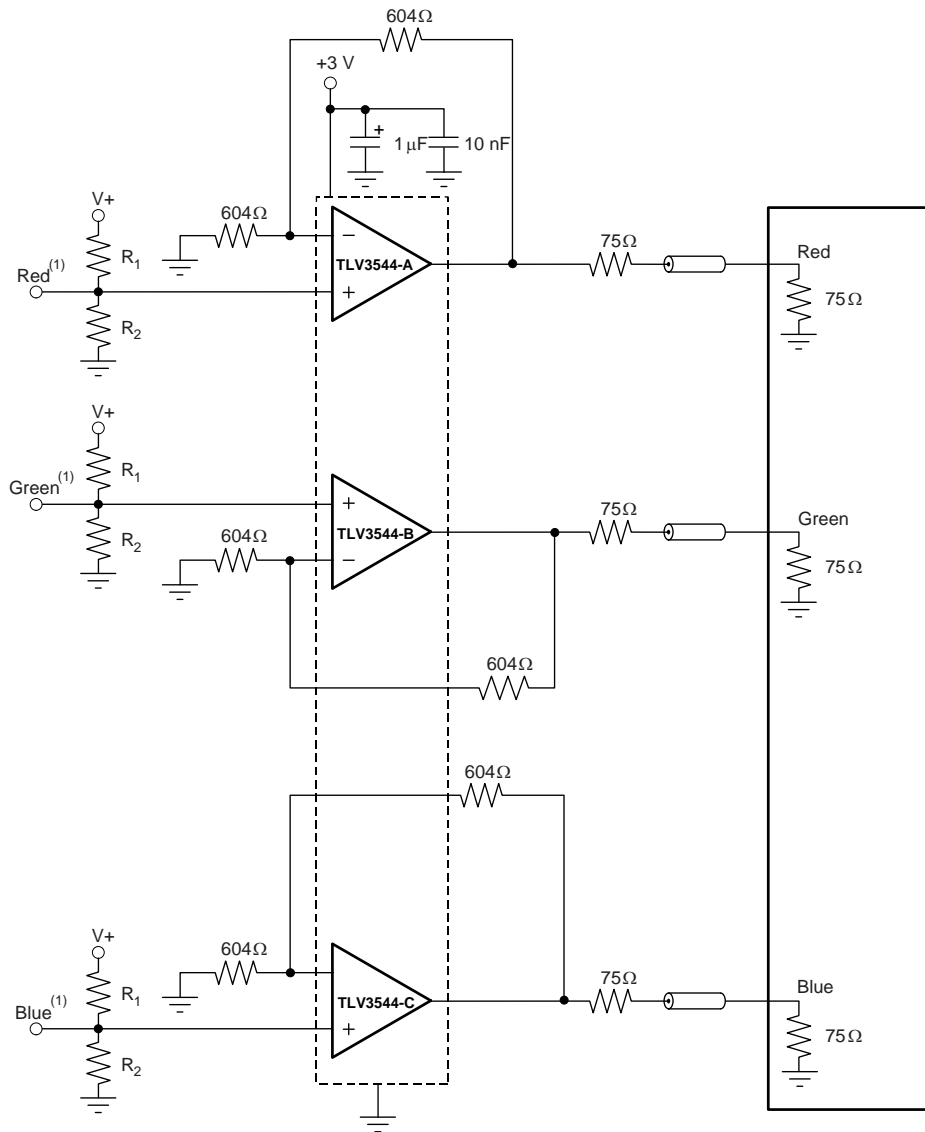

Figure 32. Single-Supply Video Line Driver

The TLV3544-Q1 can be used as an amplifier for RGB graphic signals, which have a voltage of zero at the video black level, by offsetting and AC-coupling the signal. See [Figure 33](#).



Copyright © 2017, Texas Instruments Incorporated

- (1) Source video signal offset 300 mV above ground to accommodate op amp swing-to-ground capability.

Figure 33. RGB Cable Driver

7.3.7 Driving Analog-to-Digital converters

The TLV3544-Q1 series op amps offer 60 ns of settling time to 0.01%, making them a good choice for driving high- and medium-speed sampling A/D converters and reference circuits. The TLV3544-Q1 provides an effective means of buffering the A/D converter input capacitance and resulting charge injection while providing signal gain. For applications requiring high DC accuracy, the [OPA350 series](#) is recommended.

Figure 34 illustrates the TLV3544-Q1 driving an A/D converter. With the TLV3544-Q1 in an inverting configuration, a capacitor across the feedback resistor can be used to filter high-frequency noise in the signal.

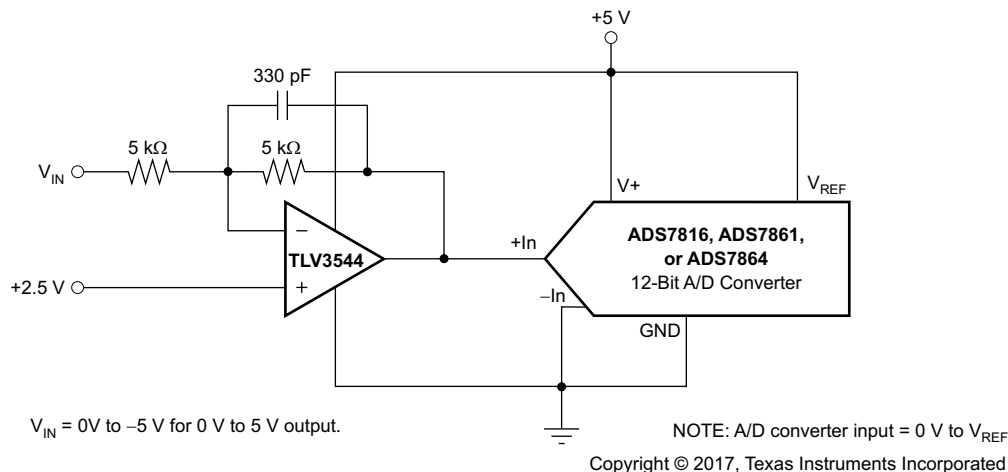

Figure 34. The TLV3544-Q1 in Inverting Configuration Driving the ADS7816

7.3.8 Capacitive Load and Stability

The TLV3544-Q1 series op amps can drive a wide range of capacitive loads. However, all op amps under certain conditions may become unstable. Op amp configuration, gain, and load value are just a few of the factors to consider when determining stability. An op amp in unity-gain configuration is most susceptible to the effects of capacitive loading. The capacitive load reacts with the device output resistance, along with any additional load resistance, to create a pole in the small-signal response that degrades the phase margin. Refer to the typical characteristic curve, *Frequency Response for Various C_L* (Figure 13) for details.

The TLV3544-Q1 topology enhances its ability to drive capacitive loads. In unity gain, these op amps perform well with large capacitive loads. Refer to the typical characteristic curves, *Recommended R_S vs Capacitive Load* (Figure 14) and *Frequency Response vs Capacitive Load* (Figure 15) for details.

One method of improving capacitive load drive in the unity-gain configuration is to insert a 10- Ω to 20- Ω resistor in series with the output, as shown in Figure 35. This configuration significantly reduces ringing with large capacitive loads—see the typical characteristic curve, *Frequency Response vs Capacitive Load* (Figure 15). However, if there is a resistive load in parallel with the capacitive load, R_S creates a voltage divider. This voltage division introduces a DC error at the output and slightly reduces output swing. This error may be insignificant. For instance, with $R_L = 10 \text{ k}\Omega$ and $R_S = 20 \Omega$, there is approximately a 0.2% error at the output.

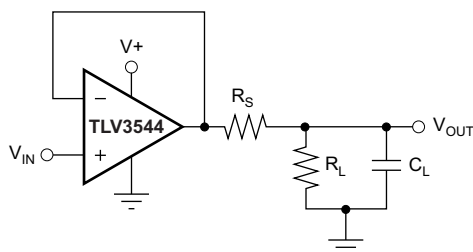

Copyright © 2017, Texas Instruments Incorporated

Figure 35. Series Resistor in Unity-Gain Configuration Improves Capacitive Load Drive

7.3.9 Wideband Transimpedance Amplifier

Wide bandwidth, low input bias current, low input voltage, and current noise make the TLV3544-Q1 an ideal wideband photodiode transimpedance amplifier for low-voltage single-supply applications. Low-voltage noise is important because photodiode capacitance causes the effective noise gain of the circuit to increase at high frequency.

The key elements to a transimpedance design, as shown in [Figure 36](#), are the expected diode capacitance [including the parasitic input common-mode and differential-mode input capacitance (2 + 2) pF for the TLV3544-Q1], the desired transimpedance gain (R_F), and the Gain-Bandwidth Product (GBW) for the TLV3544-Q1 (100 MHz typical). With these three variables set, the feedback capacitor value (C_F) may be set to control the frequency response.

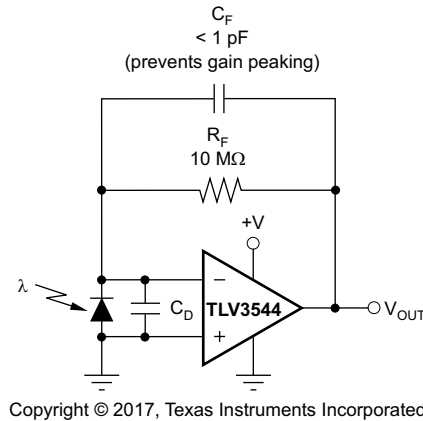

Figure 36. Transimpedance Amplifier

To achieve a maximally flat, second-order, Butterworth frequency response, the feedback pole must be set as shown in [Equation 1](#):

$$\frac{1}{2\pi R_F C_F} = \sqrt{\frac{\text{GBP}}{4\pi R_F C_D}} \quad (1)$$

Typical surface-mount resistors have a parasitic capacitance of approximately 0.2 pF that must be deducted from the calculated feedback capacitance value. Bandwidth is calculated by [Equation 2](#):

$$f_{-3\text{dB}} = \sqrt{\frac{\text{GBP}}{2\pi R_F C_D}} \text{ Hz} \quad (2)$$

For even higher transimpedance bandwidth, the high-speed CMOS [OPA355](#) (200-MHz GBW) or the [OPA655](#) (400-MHz GBW) may be used.

7.4 Device Functional Modes

The TLV3544-Q1 is powered on when the supply is connected. The devices can be operated as single-supply operational amplifiers or dual-supply amplifiers depending on the application. The devices can also be used with asymmetrical supplies as long as the differential voltage (V_- to V_+) is at least 1.8 V and no greater than 5.5 V (example: V_- set to -3.5 V and V_+ set to 1.5 V).

8 Application and Implementation

NOTE

Information in the following applications sections is not part of the TI component specification, and TI does not warrant its accuracy or completeness. TI's customers are responsible for determining suitability of components for their purposes. Customers should validate and test their design implementation to confirm system functionality.

8.1 Application Information

The TLV3544-Q1 is a CMOS, rail-to-rail I/O, high-speed, voltage-feedback operational amplifier designed for video, high-speed, and other applications. The amplifier features a 100-MHz gain bandwidth, and 150-V/ μ s slew rate, but it is unity-gain stable and can be operated as a 1-V/V voltage follower.

8.2 Typical Application

Wide gain bandwidth, low input bias current, low input voltage, and current noise make the TLV3544-Q1 an ideal wideband photodiode transimpedance amplifier. Low-voltage noise is important because photodiode capacitance causes the effective noise gain of the circuit to increase at high frequency. The key elements to a transimpedance design, as shown in [Figure 37](#), are the expected diode capacitance, which include the parasitic input common-mode and differential-mode input capacitance; the desired transimpedance gain; and the gain-bandwidth (GBW) for the TLV3544-Q1 (20 MHz). With these three variables set, the feedback capacitor value can be set to control the frequency response. Feedback capacitance includes the stray capacitance of, which is 0.2 pF for a typical surface-mount resistor.

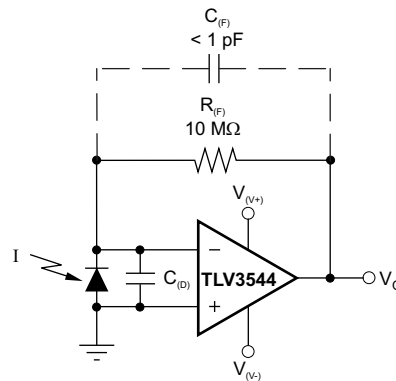

Copyright © 2017, Texas Instruments Incorporated

Figure 37. Dual-Supply Transimpedance Amplifier

8.2.1 Design Requirements

For this design example, use the parameters listed in [Table 2](#) as the input parameters.

Table 2. Design Parameters

PARAMETER	EXAMPLE VALUE
Supply voltage, $V_{(V+)}$	2.5 V
Supply voltage, $V_{(V-)}$	-2.5 V

$C_{(F)}$ is optional to prevent gain peaking. $C_{(F)}$ includes the stray capacitance of $R_{(F)}$.

8.2.2 Detailed Design Procedure

To achieve a maximally-flat, second-order Butterworth frequency response, set the feedback pole using [Equation 3](#).

$$\frac{1}{2 \times \pi \times R_{(F)} \times C_{(F)}} = \sqrt{\frac{GBW}{4 \times \pi \times R_{(F)} \times C_{(D)}}} \quad (3)$$

Calculate the bandwidth using [Equation 4](#).

$$f_{(-3 \text{ dB})} = \sqrt{\frac{GBW}{2 \times \pi \times R_{(F)} \times C_{(D)}}} \quad (4)$$

8.2.2.1 Optimizing the Transimpedance Circuit

To achieve the best performance, components must be selected according to the following guidelines:

1. For lowest noise, select $R_{(F)}$ to create the total required gain. Using a lower value for $R_{(F)}$ and adding gain after the transimpedance amplifier generally produces poorer noise performance. The noise produced by $R_{(F)}$ increases with the square-root of $R_{(F)}$, whereas the signal increases linearly. Therefore, signal-to-noise ratio improves when all the required gain is placed in the transimpedance stage.
2. Minimize photodiode capacitance and stray capacitance at the summing junction (inverting input). This capacitance causes the voltage noise of the op amp to be amplified (increasing amplification at high frequency). Using a low-noise voltage source to reverse-bias a photodiode can significantly reduce the capacitance. Smaller photodiodes have lower capacitance. Use optics to concentrate light on a small photodiode.
3. Noise increases with increased bandwidth. Limit the circuit bandwidth to only that required. Use a capacitor across the $R_{(F)}$ to limit bandwidth, even if not required for stability.
4. Circuit board leakage can degrade the performance of an otherwise well-designed amplifier. Clean the circuit board carefully. A circuit board guard trace that encircles the summing junction and is driven at the same voltage can help control leakage.

8.2.3 Application Curve

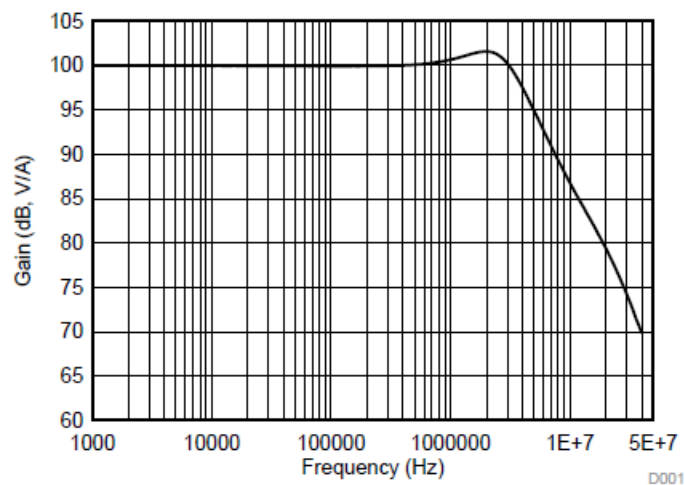

Figure 38. AC Transfer Function

9 Power Supply Recommendations

The TLV3544-Q1 is specified for operation from 2.5 V to 5.5 V (± 1.25 to ± 2.75 V); many specifications apply from -40°C to $+125^{\circ}\text{C}$. Parameters that can exhibit significant variance with regard to operating voltage or temperature are shown [Typical Characteristics](#).

Place 0.1- μF bypass capacitors close to the power-supply pins to reduce errors coupling in from noisy or high impedance power supplies. For more detailed information on bypass capacitor placement, see [Layout Guidelines](#).

10 Layout

10.1 Layout Guidelines

Good high-frequency printed-circuit board (PCB) layout techniques must be employed for the TLV3544-Q1. Generous use of ground planes, short and direct signal traces, and a suitable bypass capacitor located at the V+ pin assure clean, stable operation. Large areas of copper also provides a means of dissipating heat that is generated in normal operation.

TI does not recommend using sockets with any high-speed amplifier.

A 10-nF ceramic bypass capacitor is the minimum recommended value; adding a 1- μF or larger tantalum capacitor in parallel can be beneficial when driving a low-resistance load. Providing adequate bypass capacitance is essential to achieving very low harmonic and intermodulation distortion.

10.2 Layout Example

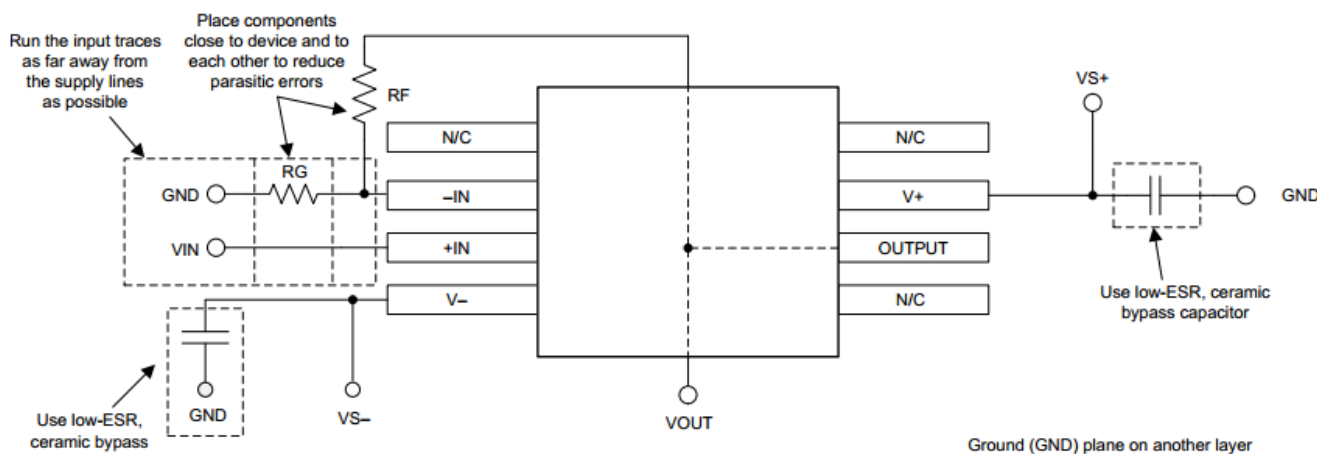

Figure 39. Operational Amplifier Board Layout for Noninverting Configuration

10.3 Power Dissipation

Power dissipation depends on power-supply voltage, signal and load conditions. With DC signals, power dissipation is equal to the product of output current times the voltage across the conducting output transistor, $V_S - V_O$. Power dissipation can be minimized by using the lowest possible power-supply voltage necessary to assure the required output voltage swing.

For resistive loads, the maximum power dissipation occurs at a DC output voltage of one-half the power-supply voltage. Dissipation with AC signals is lower. [AB-039 Power Amplifier Stress and Power Handling Limitations](#) explains how to calculate or measure power dissipation with unusual signals and loads, and can be found at www.ti.com.

Power Dissipation (continued)

Any tendency to activate the thermal protection circuit indicates excessive power dissipation or an inadequate heatsink. For reliable operation, junction temperature must be limited to 150°C, maximum. To estimate the margin of safety in a complete design, increase the ambient temperature until the thermal protection is triggered at 160°C. The thermal protection should trigger more than 35°C above the maximum expected ambient condition of the application.

11 Device and Documentation Support

11.1 Documentation Support

For related documentation see the following:

- [ADS8326 16-Bit, High-Speed, 2.7V to 5.5V microPower Sampling ANALOG-TO-DIGITAL CONVERTER](#)
- [Circuit Board Layout Techniques](#)
- [Compensate Transimpedance Amplifiers Intuitively](#)
- [FilterPro™ User's Guide](#)
- [Noise Analysis for High-Speed Op Amps](#)
- [OPA380 and OPA2380 Precision, High-Speed Transimpedance Amplifier](#)
- [OPA355, OPA2355, and OPA3355 200MHz, CMOS OPERATIONAL AMPLIFIER WITH SHUTDOWN](#)
- [OPA656 Wideband, Unity-Gain Stable, FET-Input OPERATIONAL AMPLIFIER](#)
- [POWER AMPLIFIER STRESS AND POWER HANDLING LIMITATIONS](#)
- [PowerPAD Thermally Enhanced Package](#)

11.2 Receiving Notification of Documentation Updates

To receive notification of documentation updates, navigate to the device product folder on ti.com. In the upper right corner, click on *Alert me* to register and receive a weekly digest of any product information that has changed. For change details, review the revision history included in any revised document.

11.3 Community Resources

The following links connect to TI community resources. Linked contents are provided "AS IS" by the respective contributors. They do not constitute TI specifications and do not necessarily reflect TI's views; see TI's [Terms of Use](#).

TI E2E™ Online Community *TI's Engineer-to-Engineer (E2E) Community*. Created to foster collaboration among engineers. At e2e.ti.com, you can ask questions, share knowledge, explore ideas and help solve problems with fellow engineers.

Design Support *TI's Design Support* Quickly find helpful E2E forums along with design support tools and contact information for technical support.

11.4 Trademarks

E2E is a trademark of Texas Instruments.
All other trademarks are the property of their respective owners.

11.5 Electrostatic Discharge Caution



These devices have limited built-in ESD protection. The leads should be shorted together or the device placed in conductive foam during storage or handling to prevent electrostatic damage to the MOS gates.

11.6 Glossary

[SLYZ022](#) — *TI Glossary*.

This glossary lists and explains terms, acronyms, and definitions.

12 Mechanical, Packaging, and Orderable Information

The following pages include mechanical, packaging, and orderable information. This information is the most current data available for the designated devices. This data is subject to change without notice and revision of this document. For browser-based versions of this data sheet, refer to the left-hand navigation.

PACKAGING INFORMATION

Orderable Device	Status (1)	Package Type	Package Drawing	Pins	Package Qty	Eco Plan (2)	Lead finish/ Ball material (6)	MSL Peak Temp (3)	Op Temp (°C)	Device Marking (4/5)	Samples
TLV3544QPWRQ1	ACTIVE	TSSOP	PW	14	2000	RoHS & Green	NIPDAU	Level-3-260C-168 HR	-40 to 125	3544Q1	Samples

(1) The marketing status values are defined as follows:

ACTIVE: Product device recommended for new designs.

LIFEBUY: TI has announced that the device will be discontinued, and a lifetime-buy period is in effect.

NRND: Not recommended for new designs. Device is in production to support existing customers, but TI does not recommend using this part in a new design.

PREVIEW: Device has been announced but is not in production. Samples may or may not be available.

OBSOLETE: TI has discontinued the production of the device.

(2) **RoHS:** TI defines "RoHS" to mean semiconductor products that are compliant with the current EU RoHS requirements for all 10 RoHS substances, including the requirement that RoHS substance do not exceed 0.1% by weight in homogeneous materials. Where designed to be soldered at high temperatures, "RoHS" products are suitable for use in specified lead-free processes. TI may reference these types of products as "Pb-Free".

RoHS Exempt: TI defines "RoHS Exempt" to mean products that contain lead but are compliant with EU RoHS pursuant to a specific EU RoHS exemption.

Green: TI defines "Green" to mean the content of Chlorine (Cl) and Bromine (Br) based flame retardants meet JS709B low halogen requirements of <=1000ppm threshold. Antimony trioxide based flame retardants must also meet the <=1000ppm threshold requirement.

(3) MSL, Peak Temp. - The Moisture Sensitivity Level rating according to the JEDEC industry standard classifications, and peak solder temperature.

(4) There may be additional marking, which relates to the logo, the lot trace code information, or the environmental category on the device.

(5) Multiple Device Markings will be inside parentheses. Only one Device Marking contained in parentheses and separated by a "-" will appear on a device. If a line is indented then it is a continuation of the previous line and the two combined represent the entire Device Marking for that device.

(6) Lead finish/Ball material - Orderable Devices may have multiple material finish options. Finish options are separated by a vertical ruled line. Lead finish/Ball material values may wrap to two lines if the finish value exceeds the maximum column width.

Important Information and Disclaimer: The information provided on this page represents TI's knowledge and belief as of the date that it is provided. TI bases its knowledge and belief on information provided by third parties, and makes no representation or warranty as to the accuracy of such information. Efforts are underway to better integrate information from third parties. TI has taken and continues to take reasonable steps to provide representative and accurate information but may not have conducted destructive testing or chemical analysis on incoming materials and chemicals. TI and TI suppliers consider certain information to be proprietary, and thus CAS numbers and other limited information may not be available for release.

In no event shall TI's liability arising out of such information exceed the total purchase price of the TI part(s) at issue in this document sold by TI to Customer on an annual basis.

OTHER QUALIFIED VERSIONS OF TLV3544-Q1 :

- Catalog: [TLV3544](#)

NOTE: Qualified Version Definitions:

- Catalog - TI's standard catalog product

TAPE AND REEL INFORMATION

QUADRANT ASSIGNMENTS FOR PIN 1 ORIENTATION IN TAPE

*All dimensions are nominal

Device	Package Type	Package Drawing	Pins	SPQ	Reel Diameter (mm)	Reel Width W1 (mm)	A0 (mm)	B0 (mm)	K0 (mm)	P1 (mm)	W (mm)	Pin1 Quadrant
TLV3544QPWRQ1	TSSOP	PW	14	2000	330.0	12.4	6.9	5.6	1.6	8.0	12.0	Q1

TAPE AND REEL BOX DIMENSIONS

*All dimensions are nominal

Device	Package Type	Package Drawing	Pins	SPQ	Length (mm)	Width (mm)	Height (mm)
TLV3544QPWRQ1	TSSOP	PW	14	2000	356.0	356.0	35.0

PW (R-PDSO-G14)

PLASTIC SMALL OUTLINE

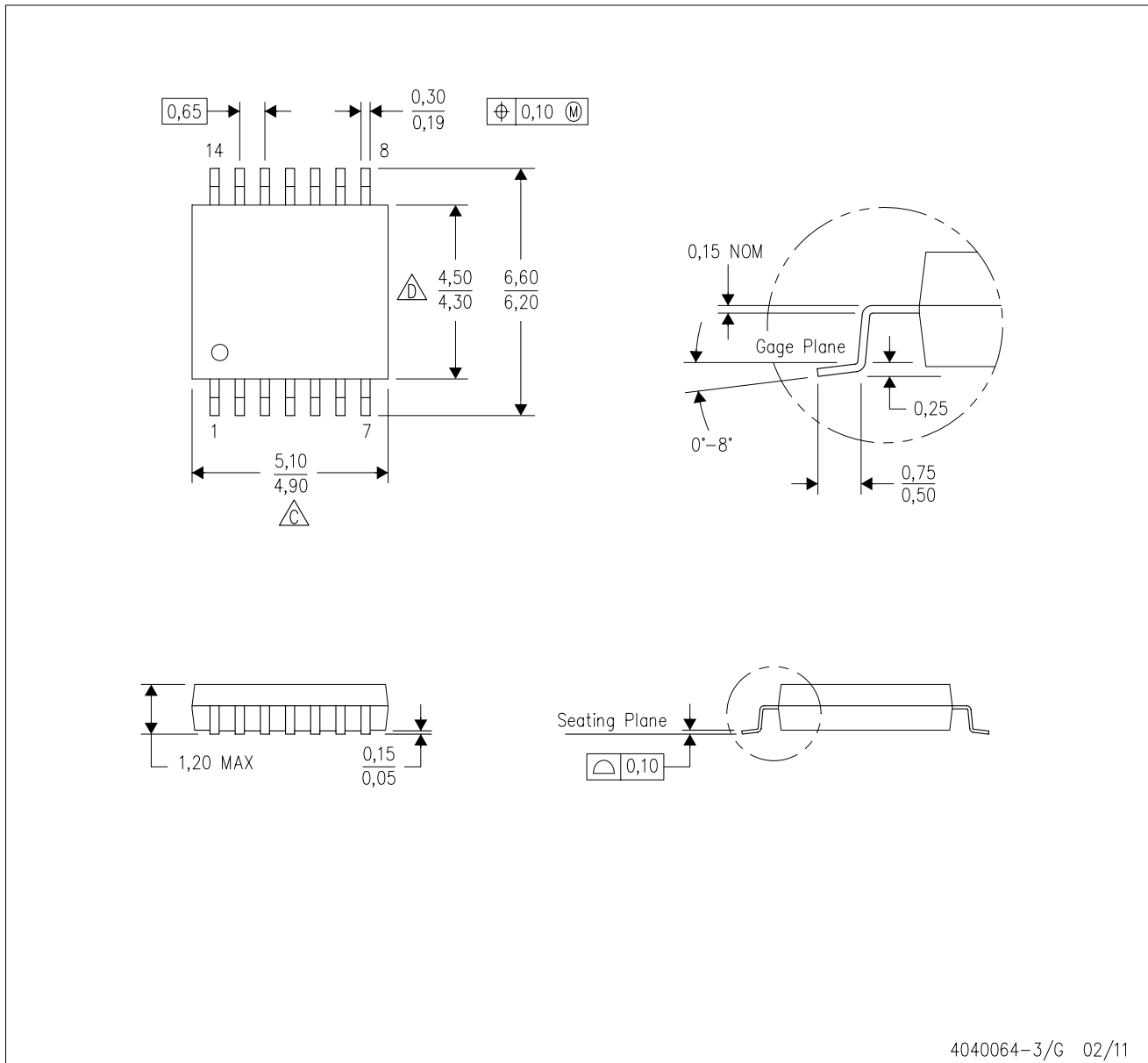

4040064-3/G 02/11

- NOTES:
- A. All linear dimensions are in millimeters. Dimensioning and tolerancing per ASME Y14.5M-1994.
 - B. This drawing is subject to change without notice.
 - C. Body length does not include mold flash, protrusions, or gate burrs. Mold flash, protrusions, or gate burrs shall not exceed 0,15 each side.
 - D. Body width does not include interlead flash. Interlead flash shall not exceed 0,25 each side.
 - E. Falls within JEDEC MO-153

IMPORTANT NOTICE AND DISCLAIMER

TI PROVIDES TECHNICAL AND RELIABILITY DATA (INCLUDING DATA SHEETS), DESIGN RESOURCES (INCLUDING REFERENCE DESIGNS), APPLICATION OR OTHER DESIGN ADVICE, WEB TOOLS, SAFETY INFORMATION, AND OTHER RESOURCES "AS IS" AND WITH ALL FAULTS, AND DISCLAIMS ALL WARRANTIES, EXPRESS AND IMPLIED, INCLUDING WITHOUT LIMITATION ANY IMPLIED WARRANTIES OF MERCHANTABILITY, FITNESS FOR A PARTICULAR PURPOSE OR NON-INFRINGEMENT OF THIRD PARTY INTELLECTUAL PROPERTY RIGHTS.

These resources are intended for skilled developers designing with TI products. You are solely responsible for (1) selecting the appropriate TI products for your application, (2) designing, validating and testing your application, and (3) ensuring your application meets applicable standards, and any other safety, security, regulatory or other requirements.

These resources are subject to change without notice. TI grants you permission to use these resources only for development of an application that uses the TI products described in the resource. Other reproduction and display of these resources is prohibited. No license is granted to any other TI intellectual property right or to any third party intellectual property right. TI disclaims responsibility for, and you will fully indemnify TI and its representatives against, any claims, damages, costs, losses, and liabilities arising out of your use of these resources.

TI's products are provided subject to [TI's Terms of Sale](#) or other applicable terms available either on [ti.com](https://www.ti.com) or provided in conjunction with such TI products. TI's provision of these resources does not expand or otherwise alter TI's applicable warranties or warranty disclaimers for TI products.

TI objects to and rejects any additional or different terms you may have proposed.

Mailing Address: Texas Instruments, Post Office Box 655303, Dallas, Texas 75265
Copyright © 2023, Texas Instruments Incorporated

Looking for pricing, stock, or lifecycle information?

Click below to explore more details on WIN SOURCE:

- ⊖ [View ACS70331EESATR-2P5B3 on WIN SOURCE](#)
- ⊖ [Allegro MicroSystems, LLC Information](#)

Optimize Your Supply Chain with WIN SOURCE Solutions

- ✓ Global Sourcing Solution
- ✓ Obsolete Management
- ✓ Cost Control Management
- ✓ Shortage Management
- ✓ Alternative Solution
- ✓ Excess Inventory Management