



**THE DATASHEET OF
SI7034-A10-IM**



DIGITAL I²C HUMIDITY AND TEMPERATURE SENSOR

Features

- Precision Relative Humidity Sensor
 - ± 4% RH (max), 0–80% RH
- High Accuracy Temperature Sensor
 - ±0.4 °C (max), –10 to 85 °C
- 0 to 100% RH operating range
- –40 to +125 °C operating range
- Low Voltage Operation
- Low Power Consumption
 - 50 nA, standby current
- Factory-calibrated
- I²C Interface
- Integrated on-chip heater
- 2x2 mm QFN package
- Excellent long term stability

Applications

- Mobile smartphones and tablets
- Consumer electronics
- HVAC/R
- Respiratory therapy
- White goods
- Asset and goods tracking
- Thermostats/humidistats
- Micro-environments/data centers
- Indoor weather stations

Description

The Si7034 I²C Humidity and Temperature Sensor is a monolithic CMOS IC integrating humidity and temperature sensor elements, an analog-to-digital converter, signal processing, calibration data, and an I²C interface. The patented use of industry-standard low-K polymeric dielectrics for sensing humidity enables the construction of low-power, monolithic CMOS Sensor ICs with low drift and hysteresis, and excellent long-term stability.

The humidity and temperature sensors are factory-calibrated and the calibration data is stored in the on-chip non-volatile memory. This ensures that the sensors are fully interchangeable, with no calibration or software changes required.

The Si7034 is available in a 2x2 mm DFN package and is reflow solderable. It can be used as a hardware- and software-compatible drop-in upgrade for existing RH/temperature sensors in 2x2 mm QFN-6 packages. The Si7034 offers an accurate, low-power, factory-calibrated digital solution ideal for measuring humidity, dew point, and temperature in applications ranging from HVAC/R and asset tracking to industrial and consumer platforms.



Ordering Information:

See page 23.

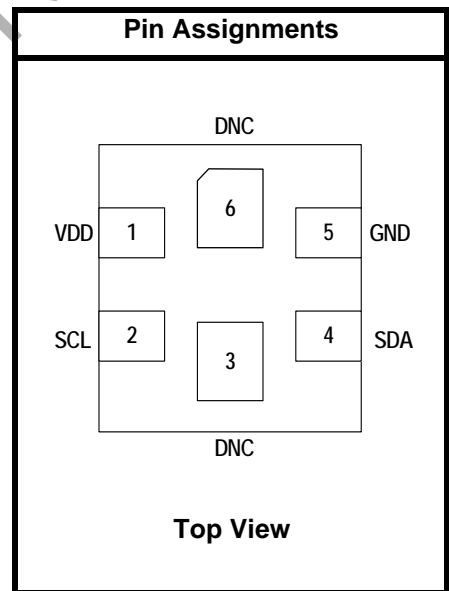

Patent Protected. Patents pending

Si7034-A10

Functional Block Diagram

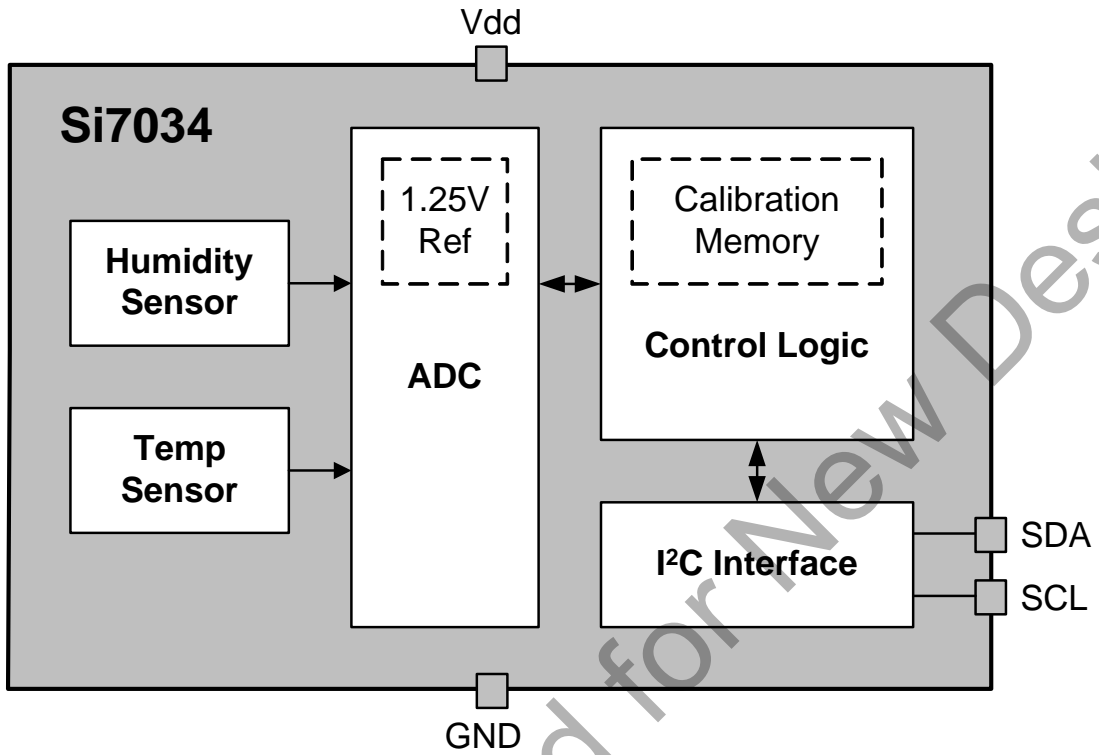

TABLE OF CONTENTS

Section	Page
1. Electrical Specifications	4
2. Typical Application Circuit	10
3. Bill of Materials	11
4. Functional Description	12
4.1. Relative Humidity Sensor Accuracy	13
4.2. Hysteresis	14
4.3. Prolonged Exposure to High Humidity	14
4.4. PCB Assembly	14
4.5. Protecting the Sensor	15
4.6. Bake/Hydrate Procedure	15
4.7. Long Term Drift/Aging	15
5. I2C Interface	16
5.1. Issuing a Measurement Command	17
5.2. Reading and Writing User Registers	18
5.3. Measuring Relative Humidity	19
5.4. Measuring Temperature	19
5.5. Firmware Revision	19
5.6. Electronic Serial Number	20
5.7. Heater	20
6. Control Registers	21
7. Pin Descriptions: Si7034 (Top View)	22
8. Ordering Guide	23
9. Package Outline	24
9.1. Package Outline: 2x2 6-pin QFN	24
10. PCB Land Pattern and Solder Mask Design	25
11. Top Marking	26
11.1. Si7034 Top Marking	26
11.2. Top Marking Explanation	26
12. Additional Reference Resources	27
Document Change List	28
Contact Information	29

Si7034-A10

1. Electrical Specifications

Unless otherwise specified, all min/max specifications apply over the recommended operating conditions.

Table 1. Recommended Operating Conditions

Parameter	Symbol	Test Condition	Min	Typ	Max	Unit
Power Supply	V _{DD}		1.67	—	1.98	V
Operating Temperature	T _A		-40	—	+125	°C

Table 2. General Specifications

1.67 ≤ V_{DD} ≤ 1.98 V; T_A = -40 to +125 °C unless otherwise noted.

Parameter	Symbol	Test Condition	Min	Typ	Max	Unit
Input Voltage High	V _{IH}	SCL, SDA pins	0.7xV _{DD}	—	—	V
Input Voltage Low	V _{IL}	SCL, SDA pins	—	—	0.3xV _{DD}	V
Input Voltage Range	V _{IN}	SCL, SDA pins with respect to GND	0.0	—	V _{DD} +2	V
Input Leakage	I _{IL}	SCL, SDA pins	—	—	1	μA
Output Voltage Low	V _{OL}	SDA pin; I _{OL} = 1.5 mA	—	—	0.4	V
Current Consumption	I _{DD}	Normal Mode, Temperature conversion in progress ¹	—	245	288	μA
		Normal Mode, RH conversion in progress ¹	—	106	145	μA
		Fast Mode, parallel temperature and RH conversion in progress ²	—	337	398	μA
		Fast Mode, RH conversion in progress ³	—	106	145	μA
		Standby, -40 to +85 °C ⁵	—	0.05	0.56	μA
		Standby, -40 to +125 °C ⁵	—	0.05	5.2	μA
		Peak I _{DD} during powerup ⁶	—	4	5.1	mA
		Peak I _{DD} during I ² C operations ⁷	—	3.5	4	mA
		After writing to user registers ⁸	—	11.6	17	μA
Heater Current ⁹	I _{HEAT}		—	6.4 to 53.5	—	mA

Notes:

1. In Normal Mode, a temperature conversion is performed first, followed by an RH conversion.
2. In Fast Mode, both a temperature conversion and an RH conversion are initiated at the same time and occur in parallel.
3. Current consumption of RH conversion after the temperature conversion has finished. In Fast Mode, the temperature conversion finishes before the RH conversion.
4. Additional time for RH conversion after the temperature conversion has finished.
5. No conversion or I²C transaction in progress. Typical values measured at 25 °C.
6. Occurs once during powerup. Duration is <5 msec.
7. Occurs during I²C commands for Reset, Read/Write User Registers, Read EID, and Read Firmware Version. Duration is <100 μs when I²C clock speed is >100 kHz (>200 kHz for 2-byte commands).
8. I_{DD} after a user register write. Initiating any other subsequent I²C transaction on the same bus (such as a user register read, starting an RH measurement, or traffic directed at other I²C devices) will transition the device to standby mode.
9. Additional current consumption when HTRE bit enabled.

Table 2. General Specifications (Continued)
 $1.67 \leq V_{DD} \leq 1.98 \text{ V}$; $T_A = -40 \text{ to } +125 \text{ }^\circ\text{C}$ unless otherwise noted.

Parameter	Symbol	Test Condition	Min	Typ	Max	Unit
Conversion Time	t_{CONV}	Normal Mode, RH conversion ¹		5.8	8.5	ms
		Normal Mode, Temperature conversion ¹		3.7	6	ms
		Fast Mode, parallel Temp and RH conversion ²		0.9	1.5	ms
		Fast Mode, additional RH conversion time ⁴		1.6	2.5	ms
Powerup Time	t_{PU}	From $V_{DD} \geq 1.67 \text{ V}$ to ready for a conversion, $25 \text{ }^\circ\text{C}$	—	10	15	ms
		From $V_{DD} \geq 1.67 \text{ V}$ to ready for a conversion, full temperature range	—	—	50	ms
		After issuing a software reset command	—	1.2	2.0	ms

Notes:

1. In Normal Mode, a temperature conversion is performed first, followed by an RH conversion.
2. In Fast Mode, both a temperature conversion and an RH conversion are initiated at the same time and occur in parallel.
3. Current consumption of RH conversion after the temperature conversion has finished. In Fast Mode, the temperature conversion finishes before the RH conversion.
4. Additional time for RH conversion after the temperature conversion has finished.
5. No conversion or I²C transaction in progress. Typical values measured at $25 \text{ }^\circ\text{C}$.
6. Occurs once during powerup. Duration is <5 msec.
7. Occurs during I²C commands for Reset, Read/Write User Registers, Read EID, and Read Firmware Version. Duration is <100 μs when I²C clock speed is >100 kHz (>200 kHz for 2-byte commands).
8. IDD after a user register write. Initiating any other subsequent I²C transaction on the same bus (such as a user register read, starting an RH measurement, or traffic directed at other I²C devices) will transition the device to standby mode.
9. Additional current consumption when HTRE bit enabled.

Table 3. I²C Interface Specifications¹
 $1.67 \leq V_{DD} \leq 1.98 \text{ V}$; $T_A = -40 \text{ to } +125 \text{ }^\circ\text{C}$ unless otherwise noted.

Parameter	Symbol	Test Condition	Min	Typ	Max	Unit
Hysteresis	V_{HYS}	High-to-low versus low-to-high transition	$0.05 \times V_{DD}$	—	—	V
SCLK Frequency ²	f_{SCL}		—	—	400	kHz
SCL High Time	t_{SKH}		0.6	—	—	μs
SCL Low Time	t_{SKL}		1.3	—	—	μs
Start Hold Time	t_{STH}		0.6	—	—	μs

Notes:

1. All values are referenced to V_{IL} and/or V_{IH} .
2. Depending on the conversion command, the Si7034 may hold the master during the conversion (clock stretch). At above 300 kHz SCL, the Si7034 may hold the master briefly for user register and device ID transactions. At the highest I²C speed of 400 kHz the stretching will be <50 μs .
3. Pulses up to and including 50 ns will be suppressed.

Si7034-A10

Table 3. I²C Interface Specifications¹ (Continued)

1.67 ≤ V_{DD} ≤ 1.98 V; T_A = -40 to +125 °C unless otherwise noted.

Parameter	Symbol	Test Condition	Min	Typ	Max	Unit
Start Setup Time	t _{STS}		0.6	—	—	μs
Stop Setup Time	t _{SPS}		0.6	—	—	μs
Bus Free Time	t _{BUF}	Between Stop and Start	1.3	—	—	μs
SDA Setup Time	t _{DS}		100	—	—	ns
SDA Hold Time	t _{DH}		100	—	—	ns
SDA Valid Time	t _{VD;DAT}	From SCL low to data valid	—	—	0.9	μs
SDA Acknowledge Valid Time	t _{VD;ACK}	From SCL low to data valid	—	—	0.9	μs
Suppressed Pulse Width ³	t _{SP}		50	—	—	ns

Notes:

1. All values are referenced to V_{IL} and/or V_{IH}.
2. Depending on the conversion command, the Si7034 may hold the master during the conversion (clock stretch). At above 300 kHz SCL, the Si7034 may hold the master briefly for user register and device ID transactions. At the highest I²C speed of 400 kHz the stretching will be <50 μs.
3. Pulses up to and including 50 ns will be suppressed.

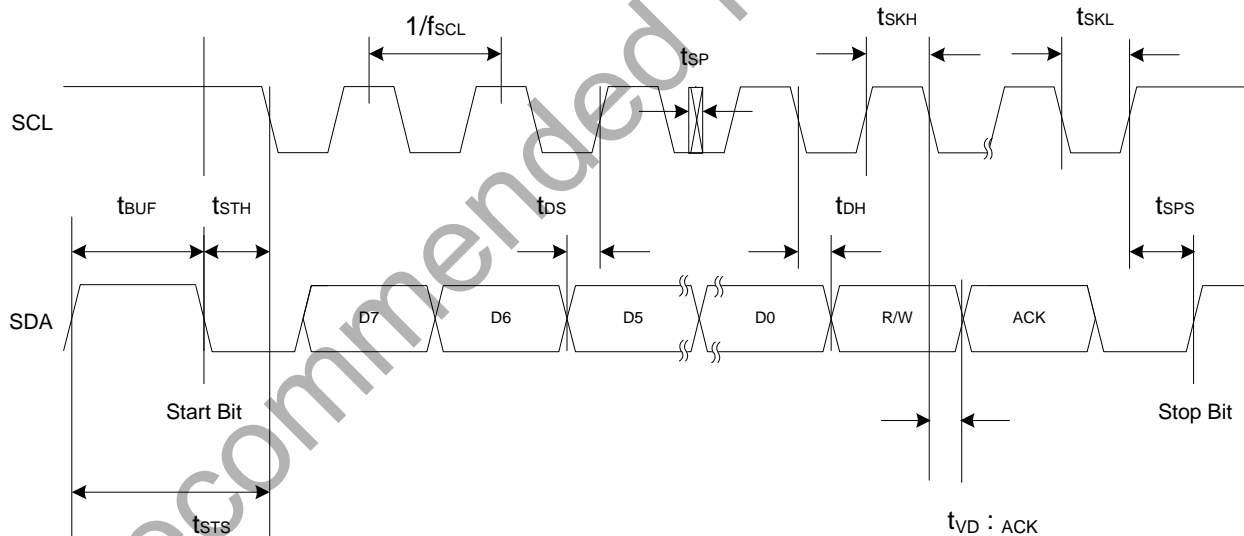

Figure 1. I²C Interface Timing Diagram

Table 4. Humidity Sensor

$1.67 \leq V_{DD} \leq 1.98 \text{ V}$; $T_A = 30 \text{ }^\circ\text{C}$ unless otherwise noted.

Parameter	Symbol	Test Condition	Min	Typ	Max	Unit
Operating Range ¹		Non-condensing	0	—	100	%RH
Accuracy ^{2, 3}		0 – 80% RH	—	±3	+4	%RH
		80 – 100% RH	See Figure 2			
Repeatability/Noise ⁴		Normal	—	0.15	—	%RH RMS
		Fast	—	0.45	—	
Response Time ⁵	$T_{63\%}$	1 m/s airflow	—	18	—	S
Drift vs. Temperature			—	0.05	—	%RH/°C
Hysteresis			—	±1	—	%RH
Long Term Stability ³			—	≤0.25	—	%RH/yr

Notes:

1. Recommended humidity operating range is 20% to 80% RH (non-condensing) over $-10 \text{ }^\circ\text{C}$ to $60 \text{ }^\circ\text{C}$. Prolonged operation beyond these ranges may result in a shift of sensor reading, with slow recovery time.
2. Excludes hysteresis, long term drift, and certain other factors and is applicable to non-condensing environments only. See **Relative Humidity Sensor Accuracy** for more details.
3. Drift due to aging effects at typical room conditions of $30 \text{ }^\circ\text{C}$ and 30% to 50% RH. May be impacted by dust, vaporized solvents or other contaminants, e.g., out-gassing tapes, adhesives, packaging materials, etc. See section “4.7. Long Term Drift/Aging”.
4. 3-sigma measurement deviation.
5. Response time to a step change in RH. Time for the RH output to change by 63% of the total RH change.

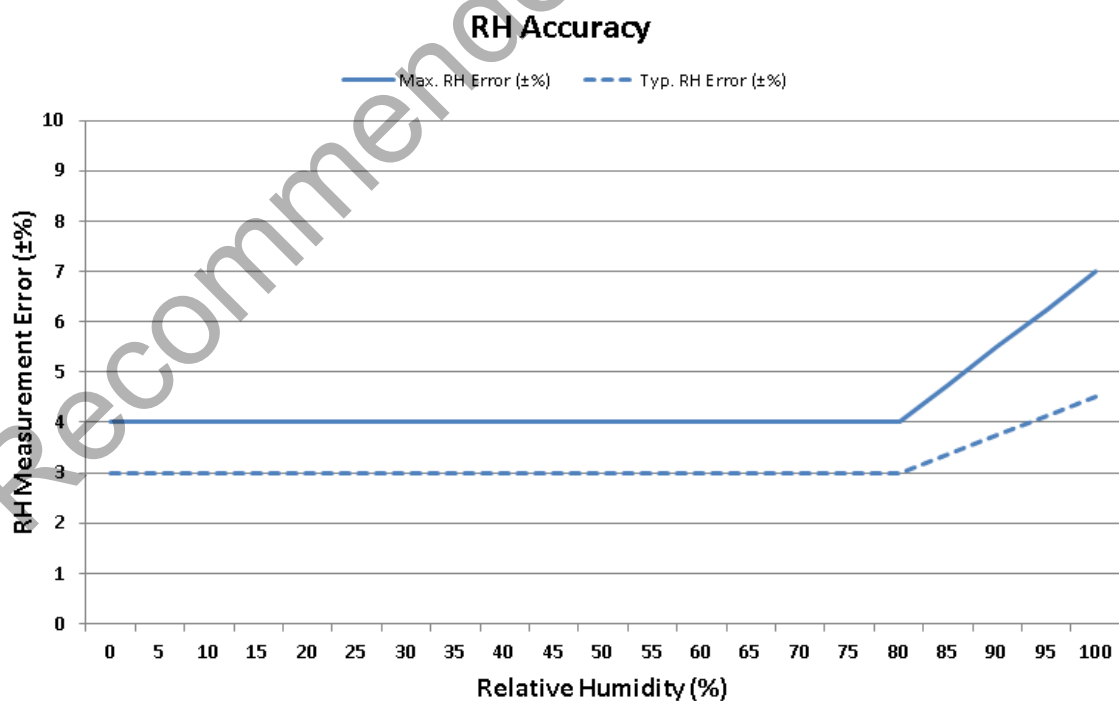
**Figure 2. RH Accuracy at 30 °C**

Si7034-A10

Table 5. Temperature Sensor

$1.67 \leq V_{DD} \leq 1.98$ V; $T_A = -40$ to $+125$ °C unless otherwise noted.

Parameter	Symbol	Test Condition	Min	Typ	Max	Unit
Operating Range			-40	—	+125	°C
Accuracy ¹		$t_A = 30$ °C	—	±0.3	±0.4	°C
		$-40 \leq t_A \leq 125$ °C	Figure 3			
Repeatability/Noise ²		Normal	—	0.03	—	°C RMS
		Fast	—	0.09	—	
Response Time ³	$T_{63\%}$	Unmounted device	—	0.7	—	s
		Si7034-EB	—	5.1	—	
Long Term Stability			—	≤ 0.01	—	°C/Yr

Notes:

1. Normal conversion time.
2. 3-sigma measurement deviation.
3. Time to reach 63% of final value in response to a step change in temperature. Actual response time will vary dependent on system thermal mass and air-flow.

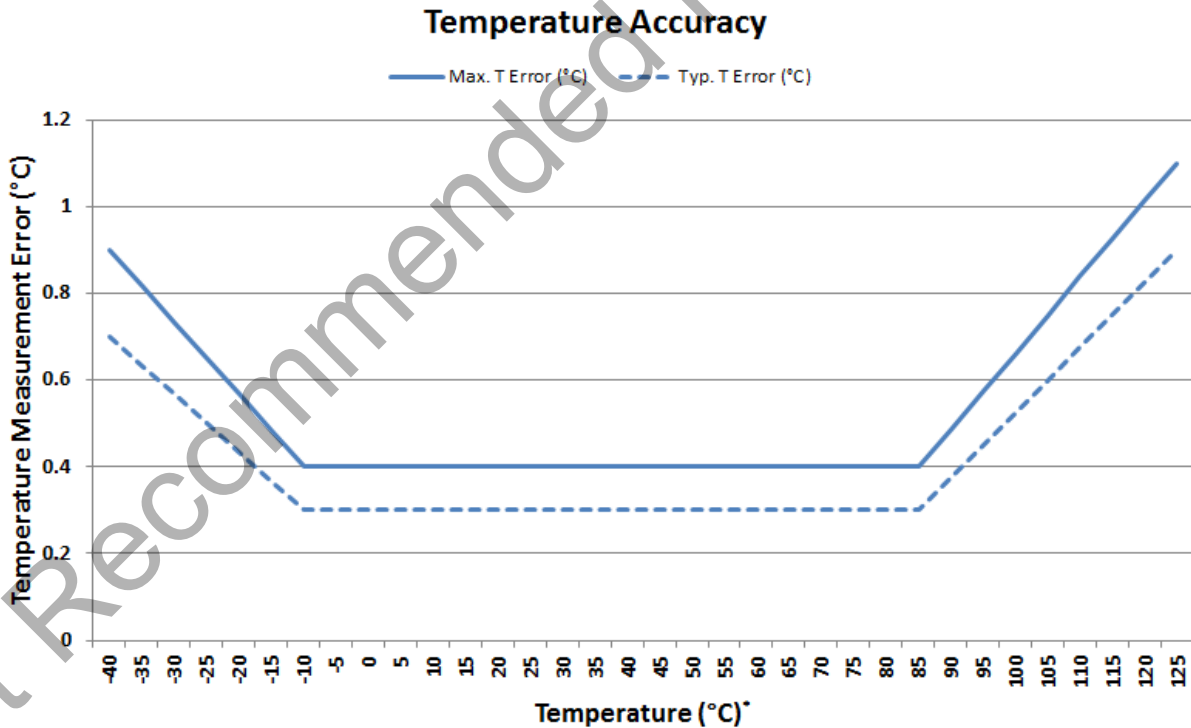

Figure 3. Temperature Accuracy

Table 6. Thermal Characteristics

Parameter	Symbol	Test Condition	QFN-6	Unit
Junction to Air Thermal Resistance	θ_{JA}	JEDEC 2-Layer Board, No Airflow	173	°C/W
Junction to Air Thermal Resistance	θ_{JA}	JEDEC 2-Layer Board, 1 m/s Airflow	153	°C/W
Junction to Air Thermal Resistance	θ_{JA}	JEDEC 2-Layer Board, 2 m/s Airflow	146	°C/W
Junction to Case Thermal Resistance	θ_{JC}	JEDEC 2-Layer Board	84	°C/W
Junction to Board Thermal Resistance	θ_{JB}	JEDEC 2-Layer Board	114	°C/W

Table 7. Absolute Maximum Ratings^{1,2}

Parameter	Symbol	Test Condition	Min	Typ	Max	Unit
Ambient temperature under bias			-55	—	125	°C
Storage Temperature			-65	—	150	°C
Voltage on I/O pins			-0.3	—	VDD+2.0 V	V
Voltage on VDD with Respect to GND			-0.3	—	2.3	V
ESD Tolerance		HBM			2	kV
		CDM			1.25	kV
		MM			250	V

Notes:

1. Absolute maximum ratings are stress ratings only, operation at or beyond these conditions is not implied and may shorten the life of the device or alter its performance.
2. Special handling considerations apply; see application note, "AN607: Si70xx Humidity and Temperature Sensor Designer's Guide".

Si7034-A10

2. Typical Application Circuit

The primary function of the Si7034 is to measure relative humidity and temperature. Figure 4 demonstrates the typical application circuit to achieve these functions; pins 3 and 6 are not required and must be left unconnected. Do not connect pins 3 and 6 to ground or pull up to VDD. They should be soldered to floating pads for mechanical stability of the package.

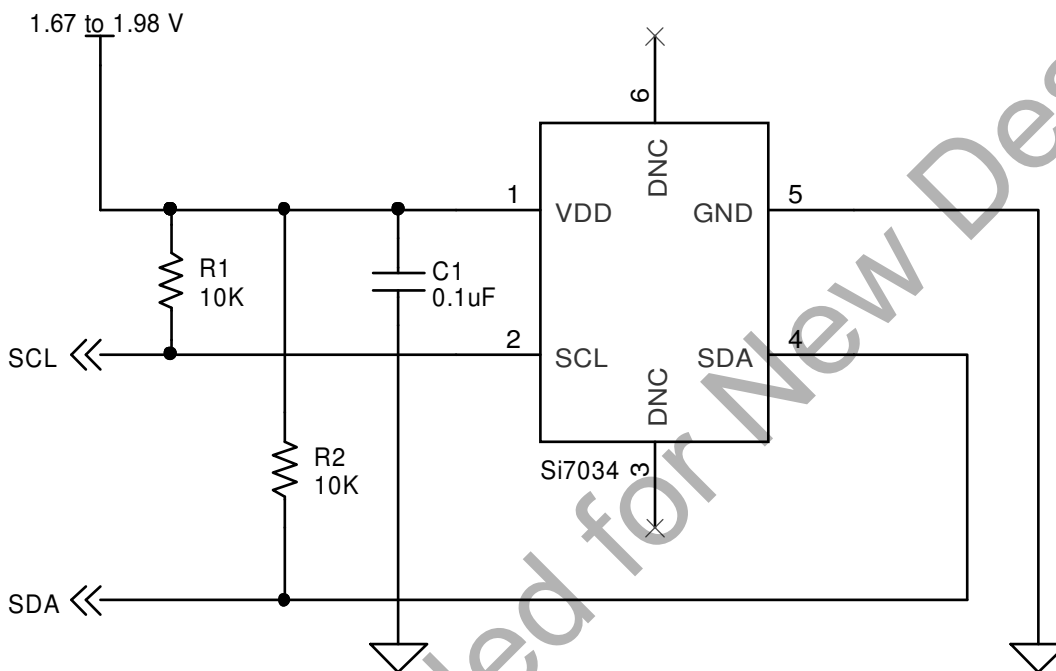

Figure 4. Typical Application Circuit for Relative Humidity and Temperature Measurement

3. Bill of Materials

Table 8. Typical Application Circuit BOM for Relative Humidity and Temperature Measurement

Reference	Description	Mfr Part Number	Manufacturer
R1	Resistor, 10 k Ω , \pm 5%, 1/16W, 0402	CR0402-16W-103JT	Venkel
R2	Resistor, 10 k Ω , \pm 5%, 1/16W, 0402	CR0402-16W-103JT	Venkel
C1	Capacitor, 0.1 μ F, 6.3 V, X7R, 0402	C0402X7R6R3-104MNP	Venkel
U1	IC, Digital Temperature/humidity Sensor	Si7034-A10-IM	Silicon Labs

4. Functional Description

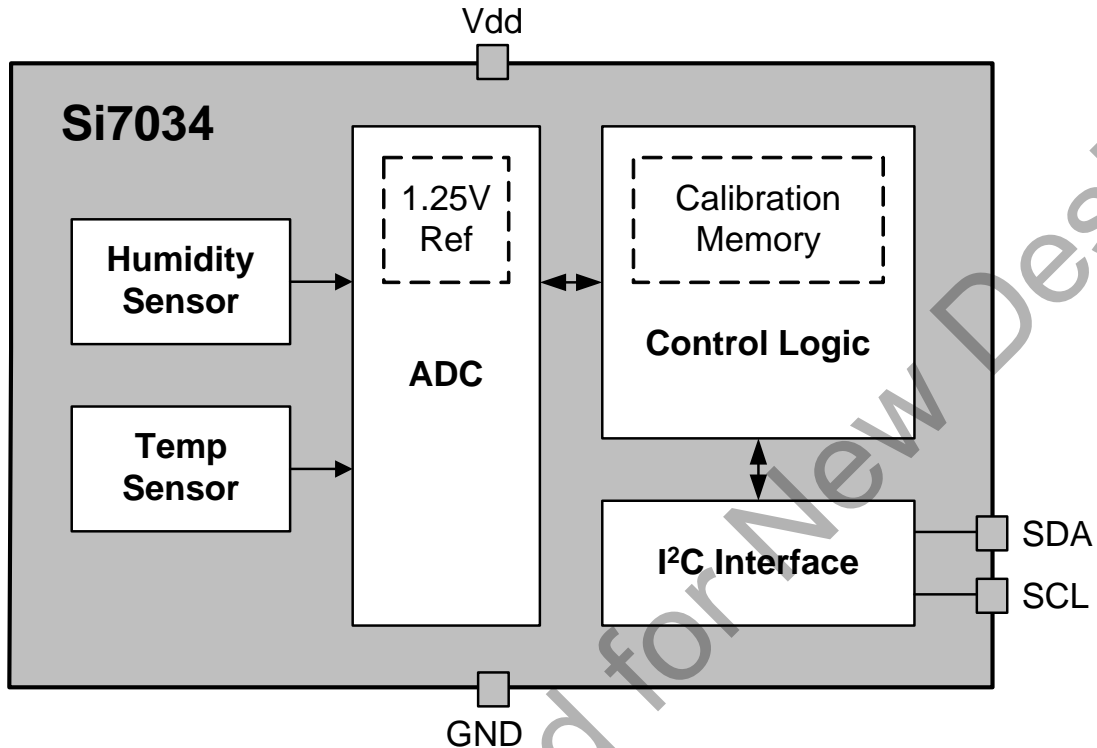

Figure 5. Si7034 Block Diagram

The Si7034 is a digital relative humidity and temperature sensor that integrates temperature and humidity sensor elements, an analog-to-digital converter, signal processing, calibration, polynomial non-linearity correction, and an I²C interface all in a single chip. The Si7034 is individually factory-calibrated for both temperature and humidity, with the calibration data stored in on-chip non-volatile memory. This ensures that the sensor is fully interchangeable, with no recalibration or changes to software required. Patented use of industry-standard CMOS low-K dielectrics as a sensor enables the Si7034 to achieve excellent long term stability and immunity to contaminants with low drift and hysteresis. The Si7034 offers a low power, high accuracy, calibrated and stable solution ideal for a wide range of temperature, humidity, and dew-point applications including medical and instrumentation, high reliability automotive and industrial systems, and cost-sensitive consumer electronics.

While the Si7034 is largely a conventional mixed-signal CMOS integrated circuit, relative humidity sensors in general and those based on capacitive sensing using polymeric dielectric have unique application and use requirements that are not common to conventional (non-sensor) ICs. Chief among those are as follows:

- The need to protect the sensor during board assembly, i.e., solder reflow, and the need to subsequently rehydrate the sensor.
- The need to protect the sensor from damage or contamination during the product life-cycle.
- The impact of prolonged exposure to extremes of temperature and/or humidity and their potential effect on sensor accuracy.
- The effects of humidity sensor “memory”.

Each of these items is discussed in more detail in the following sections.

4.1. Relative Humidity Sensor Accuracy

To determine the accuracy of a relative humidity sensor, it is placed in a temperature and humidity controlled chamber. The temperature is set to a convenient fixed value (typically 25–30 °C) and the relative humidity is swept from 20 to 80% and back to 20% in the following steps: 20% – 40% – 60% – 80% – 80% – 60% – 40% – 20%. At each set-point, the chamber is allowed to settle for a period of 30 minutes before a reading is taken from the sensor. Prior to the sweep, the device is allowed to stabilize to 50%RH. The solid trace in Figure 6, “Measuring Sensor Accuracy Including Hysteresis,” shows the result of a typical sweep.

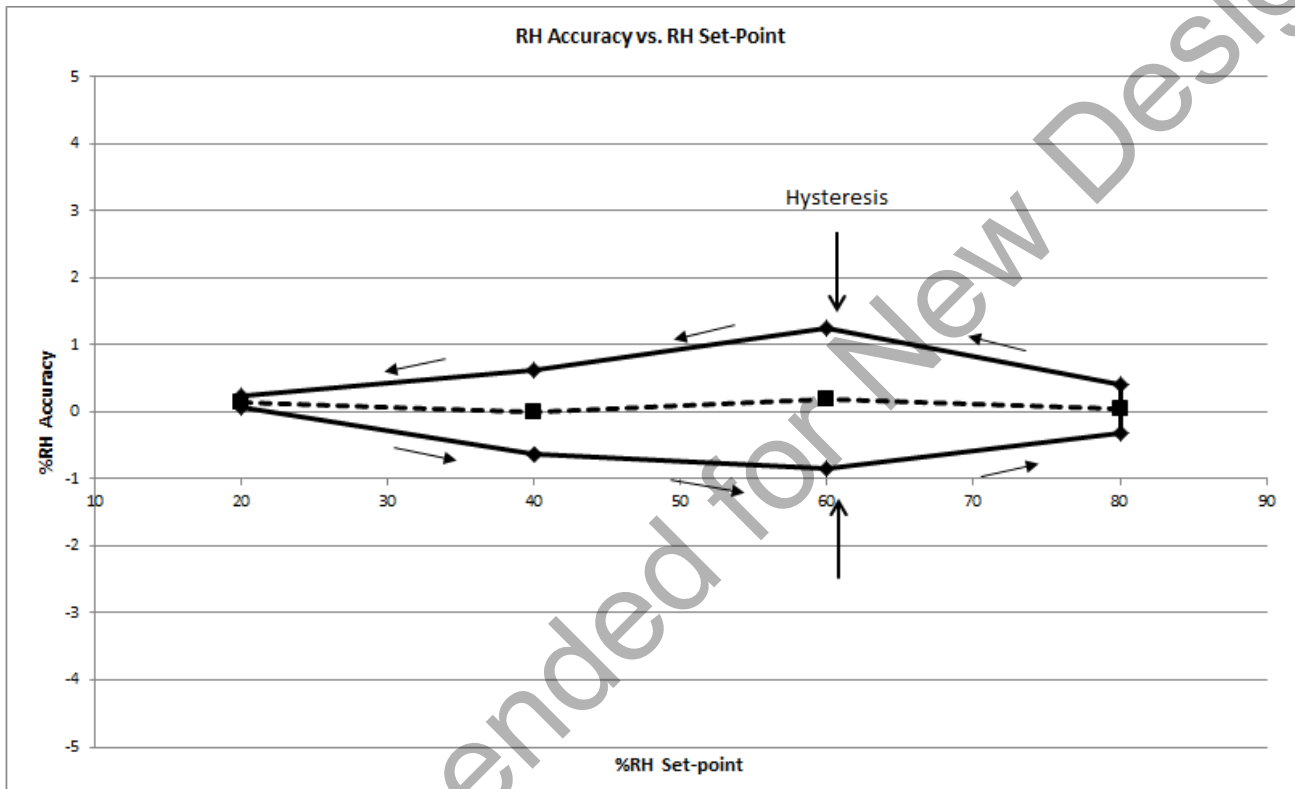

Figure 6. Measuring Sensor Accuracy Including Hysteresis

The RH accuracy is defined as the dotted line shown in Figure 6, which is the average of the two data points at each relative humidity set-point. In this case, the sensor shows an accuracy of 0.25%RH. The Si7034 accuracy specification (Table 4) includes:

- Unit-to-unit and lot-to-lot variation in non-linearity compensation
- Accuracy of factory calibration
- Margin for shifts that can occur during IR solder reflow (compensation for shift due to reflow is included in the linearization procedure below)

The accuracy specification does not include:

- Hysteresis (typically $\pm 1\%$).
- Effects from long term exposure to very humid conditions
- Contamination of the sensor by particulates, chemicals, etc.
- Other aging related shifts (“Long-term stability”)
- Variations due to temperature. RH readings will typically vary with temperature by $< \pm 0.05\% / ^\circ\text{C}$.

4.2. Hysteresis

The moisture absorbent film (polymeric dielectric) of the humidity sensor will carry a memory of its exposure history, particularly its recent or extreme exposure history. A sensor exposed to relatively low humidity will carry a negative offset relative to the factory calibration, and a sensor exposed to relatively high humidity will carry a positive offset relative to the factory calibration. This factor causes a hysteresis effect illustrated by the solid trace in Figure 5. The hysteresis value is the difference in %RH between the maximum absolute error on the decreasing humidity ramp and the maximum absolute error on the increasing humidity ramp at a single relative humidity setpoint and is expressed as a bipolar quantity relative to the average error (dashed trace). In the example of Figure 5, the measurement uncertainty due to the hysteresis effect is +/-1.0%RH.

4.3. Prolonged Exposure to High Humidity

Prolonged exposure to high humidity will result in a gradual upward drift of the RH reading. The shift in sensor reading resulting from this drift will generally disappear slowly under normal ambient conditions. The amount of shift is proportional to the magnitude of relative humidity and the length of exposure. In the case of lengthy exposure to high humidity, some of the resulting shift may persist indefinitely under typical conditions. It is generally possible to substantially reverse this affect by baking the device (see section "4.6. Bake/Hydrate Procedure").

4.4. PCB Assembly

4.4.1. Soldering

Like most ICs, Si7034 devices are shipped from the factory vacuum-packed with an enclosed desiccant to avoid any RH accuracy drift during storage and to prevent any moisture-related issues during solder reflow. The following guidelines should be observed during PCB assembly:

- Si7034 devices are compatible with standard board assembly process. Devices should be soldered using reflow per the recommended card reflow profile. See Section "10. PCB Land Pattern and Solder Mask Design" for the recommended card reflow profile.
- A "no clean" solder process is recommended to minimize the need for water or solvent rinses after soldering. Cleaning after soldering is possible, but must be done carefully to avoid impacting the performance of the sensor. See AN607 for more information on cleaning.
- It is essential that the exposed polymer sensing film be kept clean and undamaged. This can be accomplished by careful handling and a clean, well-controlled assembly process. When in doubt or for extra protection, a heat-resistant, protective cover such as Kapton(R) KPPD-1/8 polyimide tape can be installed during PCB assembly.

4.4.2. Rehydration

The measured humidity value will generally shift slightly after solder reflow. A portion of this shift is permanent and is accounted for in the accuracy specifications in Table 4. After soldering, an Si7034 should be allowed to equilibrate under controlled RH conditions (room temperature, 45–55%RH) for at least 48 hours to eliminate the remainder of the shift and return the device to its specified accuracy performance.

4.4.3. Rework

To maintain the specified sensor performance, care must be taken during rework to minimize the exposure of the device to excessive heat and to avoid damage/contamination or a shift in the sensor reading due to liquids, solder flux, etc. Manual touch-up using a soldering iron is permissible under the following guidelines:

- The exposed polymer sensing film must be kept clean and undamaged. A Kapton® tape protective cover is recommended during any rework operation.
- Flux must not be allowed to contaminate the sensor; liquid flux is not recommended even with a cover in place. Conventional lead-free solder with rosin core is acceptable for touch-up as long as a cover is in place during the rework.
- If possible, avoid water or solvent rinses after touch-up. Cleaning after soldering is possible, but must be done carefully to avoid impacting the performance of the sensor. See AN607 for more information on cleaning.

- Minimize the heating of the device. Soldering iron temperatures should not exceed 350 °C and that the contact time per pin should not exceed 5 seconds.
- Hot air rework is not recommended. If a device must be replaced, remove the device by hot air and solder a new part in its place by reflow following the guidelines above.

***Note:** All trademarks are the property of their respective owners.

4.5. Protecting the Sensor

Because the sensor operates on the principal of measuring a change in capacitance, any changes to the dielectric constant of the polymer film will be detected as a change in relative humidity. Therefore, it is important to minimize the probability of contaminants coming into contact with the sensor. Dust and other particles as well as liquids can affect the RH reading. Depending on the needs of the application, there may be a need for basic protection against particulates or something more sophisticated such as a hydrophobic membrane providing up to IP67 compliant protection, during PCB assembly and/or the end system.

4.6. Bake/Hydrate Procedure

After exposure to extremes of temperature and/or humidity for prolonged periods, the polymer sensor film can become either very dry or very wet, in each case the result is either high or low relative humidity readings. Under normal operating conditions, the induced error will diminish over time. From a very dry condition, such as after shipment and soldering, the error will diminish over a few days at typical controlled ambient conditions, e.g., 48 hours of $45 \leq \%RH \leq 55$. However, from a very wet condition, recovery may take significantly longer. To accelerate recovery from a wet condition, a bake and hydrate cycle can be implemented. This operation consists of the following steps:

- Baking the sensor at 125 °C for ≥ 12 hours
- Hydration at 30 °C in 75% RH for ≥ 10 hours

Following this cycle, the sensor will return to normal operation in typical ambient conditions after a few days.

4.7. Long Term Drift/Aging

Over long periods of time, the sensor readings may drift due to aging of the device. Standard accelerated life testing of the Si7034 has resulted in the specifications for long-term drift shown in Table 4 and Table 5. This contribution to the overall sensor accuracy accounts only for the long-term aging of the device in an otherwise benign operating environment and does not include the effects of damage, contamination, or exposure to extreme environmental conditions.

Si7034-A10

5. I²C Interface

The Si7034 communicates with the Host controller over a digital I²C interface. The 7-bit base slave address is 0x70.

Table 9. I²C Slave Address Byte

A6	A5	A4	A3	A2	A1	A0	R/W
1	1	1	0	0	0	0	1/0

Master I²C devices communicate with the Si7034 using a command structure. The commands are listed in the I²C command table. Commands other than those documented below are undefined and should not be sent to the device.

Table 10. I²C Command Table

Command	Hold/No Hold Mode	Hex Code
Read Electronic ID: Two Separate IDs with checksum	—	0xFA 0x0F
Read Electronic ID: Two Separate IDs with checksum	—	0xFC 0xC9
Soft Reset	—	0xFE
Temperature and Relative Humidity Measurement: Normal Mode	Hold Mode	0x7C 0xA2
Temperature and Relative Humidity Measurement: Normal Mode	No Hold Mode	0x78 0x66
Temperature and Relative Humidity Measurement: Fast Mode	Hold Mode	0x64 0x58
Temperature and Relative Humidity Measurement: Fast Mode	No Hold Mode	0x60 0x9C
Query Device	Device will ACK command, No Functional Effect or response	0x80 0x5D
Query Device	Response 0x00 0x47 0x2B	0xEF 0xC8
Write Heater Control Register	Hold Mode	0xE6
Read Heater Control Register	Hold Mode	0xE7
Read Firmware Revision	—	0x84 0xF1

5.1. Issuing a Measurement Command

The measurement commands instruct the Si7034 to perform Relative Humidity and Temperature measurements. The procedure to issue any one of these commands is identical. While the measurement is in progress, the option of either clock stretching (Hold Master Mode) or Not Acknowledging read requests (No Hold Master Mode) is available to indicate to the master that the measurement is in progress; the chosen command code determines which mode is used. A checksum byte is returned from the slave for use in checking for transmission errors. The checksum byte will follow the least significant measurement byte. The checksum byte is calculated using a CRC generator polynomial of $x^8 + x^5 + x^4 + 1$, with an initialization of 0xFC.

Table 11. I²C Bit Descriptions

Name	Symbol	Description
START	S	SDA goes low while SCL high.
STOP	P	SDA goes high while SCL high.
Repeated START	Sr	SDA goes low while SCL high. It is allowable to generate a STOP before the repeated start. SDA can transition to high before or after SCL goes high in preparation for generating the START.
READ	R	Read bit = 1
WRITE	W	Write bit = 0
All other bits	—	SDA value must remain high or low during the entire time SCL is high (this is the set up and hold time in Figure 1).

In the I²C sequence diagrams in the following sections, bits produced by the master and slave are color coded as shown:

Master	Slave
--------	-------

Sequence to perform a measurement and read back result (Hold Mode)

S	Slave Address	W	A	Command Byte 1	A	Command Byte 2	A	Sr	Slave Address
---	---------------	---	---	----------------	---	----------------	---	----	---------------

R	A	Clock Stretch During Measurement	Temp MSB	A	Temp LSB	A	Checksum	A
---	---	----------------------------------	----------	---	----------	---	----------	---

Humidity MSB	A	Humidity LSB	A	Checksum	NA	P
--------------	---	--------------	---	----------	----	---

Si7034-A10

Sequence to perform a measurement and read back result (No Hold Mode)

S	Slave Address	W	A	Command Byte 1	A	Command Byte 2	A	Sr	Slave Address
---	---------------	---	---	----------------	---	----------------	---	----	---------------

R	NA*	Sr	Slave Address	R	A	Temp MSB	A	Temp LSB	A	Checksum	A
---	-----	----	---------------	---	---	----------	---	----------	---	----------	---

Humidity MSB	A	Humidity LSB	A	Checksum	NA	P
--------------	---	--------------	---	----------	----	---

***Note:** Device will NACK the slave address byte until conversion is complete.

5.2. Reading and Writing User Registers

The Heater Control Register allows the user to set the configuration of the Si7034. The procedure for accessing this register is described below. A checksum byte is not provided after reading a user register.

Sequence to read a register

S	Slave Address	W	A	Read Reg Cmd	A	Sr	Slave Address	R	A	Read Data	NA	P
---	---------------	---	---	--------------	---	----	---------------	---	---	-----------	----	---

Sequence to write a register

S	Slave Address	W	A	Write Reg Cmd	A	Write Data	A	P
---	---------------	---	---	---------------	---	------------	---	---

5.3. Measuring Relative Humidity

Once a relative humidity measurement has been made, the results of the measurement may be converted to percent relative humidity by using the following expression:

$$\%RH = 100 \times \frac{RH_Code}{2^{16}}$$

Where:

%RH is the measured relative humidity value in %RH

RH_Code is the 16-bit word returned by the Si7034

5.4. Measuring Temperature

Each time a relative humidity measurement is made a temperature measurement is also made for the purposes of temperature compensation of the relative humidity measurement. The results of the temperature measurement may be converted to temperature in degrees Celsius (°C) using the following expression:

$$T = -45 + 175 \times \frac{Temp_Code}{2^{16}}$$

Where:

Temperature (°C) is the measured temperature value in °C

Temp_Code is the 16-bit word returned by the Si7034

5.5. Firmware Revision

The internal firmware revision can be read with the following I²C transaction:

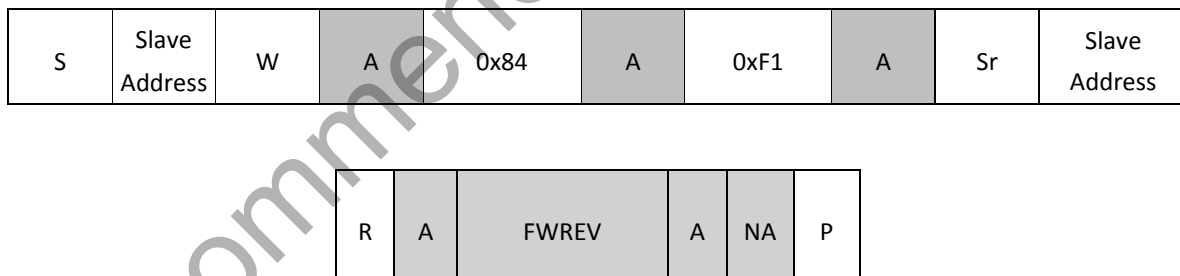

The values in this field are encoded as follows:

0x10 = Firmware version 1.0

Si7034-A10

5.6. Electronic Serial Number

The Si7034 provides a serial number individualized for each device that can be read via the I²C serial interface.

Two I²C commands are required to access the device memory and retrieve the complete serial number. The command sequence, and format of the serial number response is described in the figure below:



First access:

S	Slave Address	W	ACK	0xFA	ACK	0X0F	ACK			
S	Slave Address	R	ACK							
	SNA_3	ACK	CRC	ACK	SNA_2	ACK	CRC	ACK		
	SNA_1	ACK	CRC	ACK	SNA_0	ACK	CRC	NACK	P	

2nd access:

S	Slave Address	W	ACK	0xFC	ACK	0XC9	ACK			
S	Slave Address	R	ACK							
	SNB_3	ACK	SNB_2	ACK	CRC	ACK				
	SNB_1	ACK	SNB_0	ACK	CRC	NACK	P			

The format of the complete serial number is 64-bits in length, divided into 8 data bytes. The complete serial number sequence is shown below:

SNA_3	SNA_2	SNA_1	SNA_0	SNB_3	SNB_2	SNB_1	SNB_0
-------	-------	-------	-------	-------	-------	-------	-------

The SNB3 field contains the device identification to distinguish between the different Silicon Labs relative humidity and temperature devices. The value of this field maps to the following devices according to this table:

0x00 or 0xFF engineering samples

0x22 = Si7034

5.7. Heater

The Si7034 contains an integrated resistive heating element that may be used to raise the temperature of the sensor. This element can be used to test the sensor, to drive off condensation, or to implement dew-point measurement when the Si7034 is used in conjunction with a separate temperature sensor such as another Si7034 (the heater will raise the temperature of the internal temperature sensor). The heater can be activated using HTRE, bit 4 in the Heater Control Register. Turning on the heater will reduce the tendency of the humidity sensor to accumulate an offset due to “memory” of sustained high humidity conditions. The heater current can be configured using bits 3:0 of the Heater Control Register.

6. Control Registers

Table 12. Register Summary

Register	Bit 7	Bit 6	Bit 5	Bit 4	Bit 3	Bit 2	Bit 1	Bit 0
Heater Control Register	RSVD			HTRE	HEATER[3:0]			

Notes:

- Any register not listed here is reserved and must not be written. The result of a read operation on these registers is undefined.
- Except where noted, reserved register bits will always read back as “1,” and are not affected by write operations. For future compatibility, it is recommended that prior to a write operation, registers should be read. Then the values read from the RSVD bits should be written back unchanged during the write operation.

Register 1. Heater Control Register

Bit	D7	D6	D5	D4	D3	D2	D1	D0
Name	RSVD			HTRE	Heater [3:0]			
Type	R/W				R/W			

Reset Settings = 0000_0000

Bit	Name	Function					
D4	HTRE	1 = On-chip Heater Enable 0 = On-chip Heater Disable					
D3:D0	HEATER[3:0]	D3	D2	D1	D0	Heater Current	
		0	0	0	0	6.4 mA	
		0	0	0	1	9.7 mA	
		0	0	1	0	13.1 mA	
				...			
		0	1	0	0	19.6 mA	
				...			
		1	0	0	0	32.4 mA	
		...					
		1	1	1	1	53.5 mA	
D7,D6, D5	RSVD	Reserved					

Si7034-A10

7. Pin Descriptions: Si7034 (Top View)

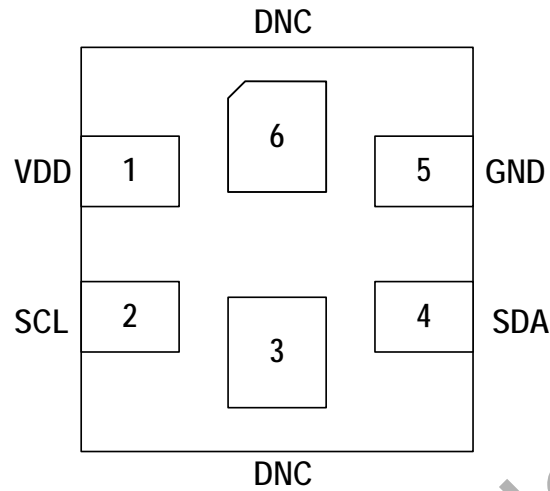

Pin Name	Pin #	Pin Description
VDD	1	Power. This pin is connected to the power supply on the circuit board.
SCL	2	I ² C clock
DNC	3,6	Do not connect electrically. It is recommended to solder to floating pads for mechanical stability. Do not connect to GND or GND plane.
SDA	4	I ² C data
GND	5	Ground. This pin is connected to ground on the circuit board.

8. Ordering Guide

Table 13. Device Ordering Guide

P/N	Description	Max. Accuracy		Package	Operating Range (°C)	Packing Format
		Temp	RH			
Si7034-A10-IM	Digital temperature/humidity sensor	±0.4 °C	± 4%	6-pin QFN	-40 to +125 °C	Cut tape
Si7034-A10-IMR	Digital temperature/humidity sensor	±0.4 °C	± 4%	6-pin QFN	-40 to +125 °C	Tape-and-reel

Si7034-A10

9. Package Outline

9.1. Package Outline: 2x2 6-pin QFN

Figure 7 illustrates the package details for the Si7034.

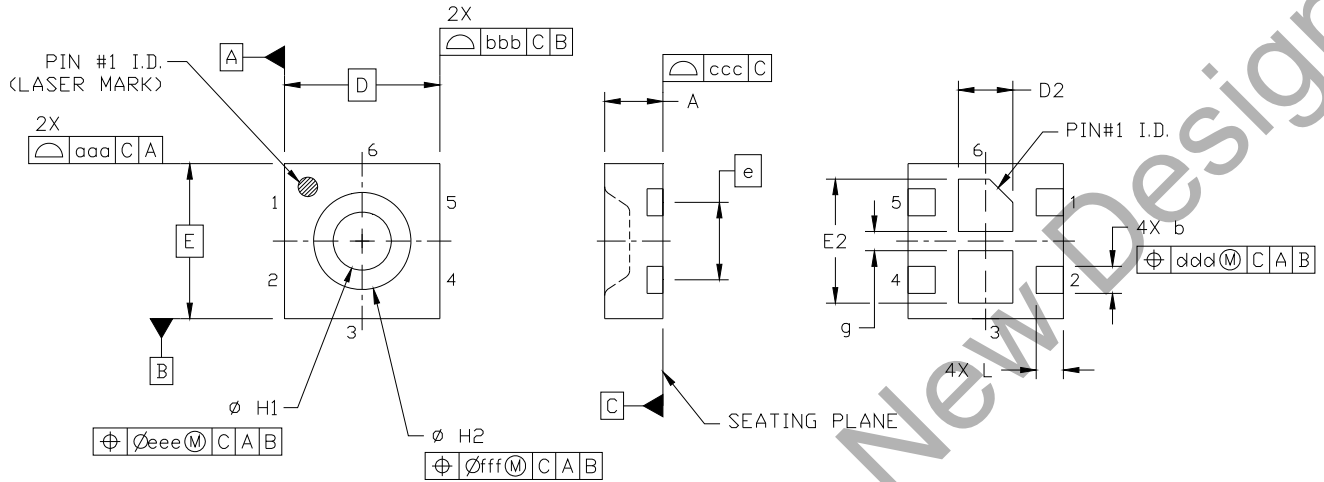

Figure 7. Si7034 Package Drawing

Table 14. Package Dimensions

Dimension	Min	Nom	Max
A	0.70	0.75	0.80
b	0.30	0.35	0.40
D	2.00 BSC		
E	2.00 BSC		
e	1.00 BSC		
D2	0.60	0.70	0.80
E2	1.50	1.60	1.70
g	0.20	0.25	0.30
H1	0.70	0.75	0.80
H2	1.20	1.25	1.30
L	0.30	0.35	0.40
aaa	0.10		
bbb	0.10		
ccc	0.08		
ddd	0.10		
eee	0.05		
fff	0.05		
Notes:			
1. All dimensions shown are in millimeters (mm).			
2. Dimensioning and Tolerancing per ANSI Y14.5M-1994.			

10. PCB Land Pattern and Solder Mask Design

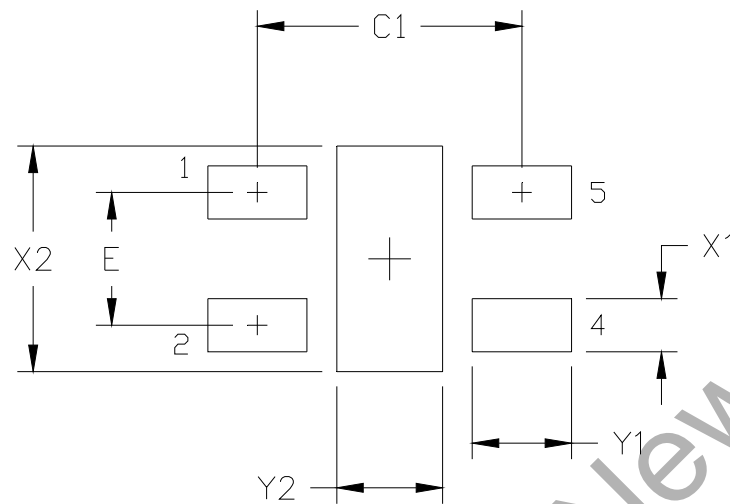

Figure 8. PCB Land Pattern Dimensions

Table 15. PCB Land Pattern Dimensions

Symbol	mm
C1	2.00
E	1.00
X1	0.40
Y1	0.75
X2	1.70
Y2	0.80

Notes:

General

1. All dimensions shown are in millimeters (mm).
2. This Land Pattern Design is based on the IPC-7351 guidelines.
3. All dimensions shown are at Maximum Material Condition (MMC). Least Material Condition (LMC) is calculated based on a Fabrication Allowance of 0.05 mm.

Solder Mask Design

4. All metal pads are to be non-solder mask defined (NSMD). Clearance between the solder mask and the metal pad is to be 60 μm minimum, all the way around the pad.

Stencil Design

5. A stainless steel, laser-cut and electro-polished stencil with trapezoidal walls should be used to assure good solder paste release.
6. The stencil thickness should be 0.125 mm (5 mils).
7. The ratio of stencil aperture to land pad size should be 1:1 for all perimeter pins.
8. A 2x1 array of 0.55 mm square openings on 0.90 mm pitch should be used for the center ground pad to achieve a target solder coverage of 50%.

Card Assembly

9. A No-Clean, Type-3 solder paste is recommended.
10. The recommended card reflow profile is per the JEDEC/IPC J-STD-020 specification for Small Body Components.

Si7034-A10

11. Top Marking

11.1. Si7034 Top Marking

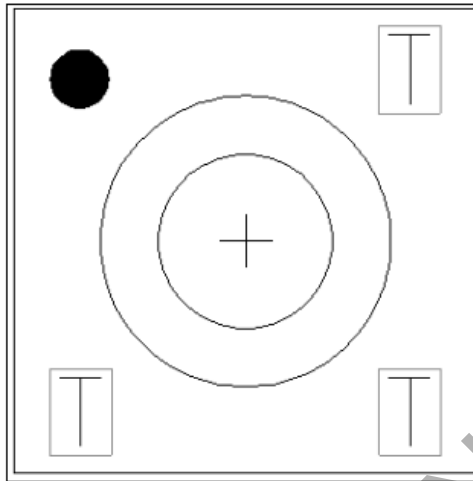

11.2. Top Marking Explanation

Mark Method:	Laser
Font Size:	0.30 mm
Line 1 Marking:	Circle = 0.25 mm Diameter, Pin #1 Indicator T = Manufacturing Trace Code Digit 1
Line 2 Marking:	TT = Manufacturing Trace Code Digits 2-3

12. Additional Reference Resources

- AN607: Si70xx Humidity and Temperature Sensor Designer's Guide

Not Recommended for New Designs

DOCUMENT CHANGE LIST

Revision 0.11 to Revision 0.3

- Updates to Section 1. “Electrical Specifications”.
- Updated Table 2. “General Specifications”.
- Updated Figure 1. “I²C Interface Timing Diagram”.
- Updated Table 12. “I²C Command Table”.
- Updated Section 4.4. “PCB Assembly”.
- Updated Section 5.2. “Reading and Writing User Registers”.
- Updated Section 5.3. “Measuring Relative Humidity”.
- Updated Section 5.4. “Measuring Temperature”.
- Updated Section 5.6. “Electronic Serial Number”.
- Updated Section 6. “Control Registers”.
- Updated Section 7. “Pin Descriptions”.
- Updated Section 8. “Package Outline”.

Revision 0.3 to Revision 0.4

- Updated Features on page 1.
- Updated Block Diagram.
- Updated Table 1.
- Updated Table 2.
- Updated Table 3.
- Updated Table 4.
- Updated Table 5.
- Updated Table 6.
- Updated Table 7.
- Updated Table 8.
- Updated Section 4.4.
- Updated Table 12.
- Updated Section 5.
- Added Section 6.
- Updated Table 13.
- Updated Section 9.
- Updated Section 10.

Revision 0.4 to Revision 0.5

- Added ESD specifications to Table 7.
- Revised Heater Control Register settings.
- Updated Firmware Revision command address.
- Corrected pin numbering in Figure 7 and Figure 8.
- Updated Table 4, “Humidity Sensor,” on page 7.
- Updated Table 5, “Temperature Sensor,” on page 8.
- Changed power supply voltage range to $\pm 10\%$.

Revision 0.5 to Revision 0.8

- Updated Table 6, “Thermal Characteristics,” on page 9.
- Updated Table 2.
- Updated Table 10.
- Updated Section 5.3.
- Updated Section 5.4.
- Updated Section 11.

Revision 0.8 to Revision 0.9

- Updated Table 2.
- Updated footnotes in Table 3.
- Updated Table 4.
- Updated descriptions in Table 10.
- Updated Table 13.
- Updated Section 5.1.
- Updated Section 5.3.
- Added Section 5.5.
- Updated Section 6.

Revision 0.9 to Revision 1.0

- Updated features on page 1.
- Updated Table 2.
- Updated Figure 4
- Updated Section 5.1.

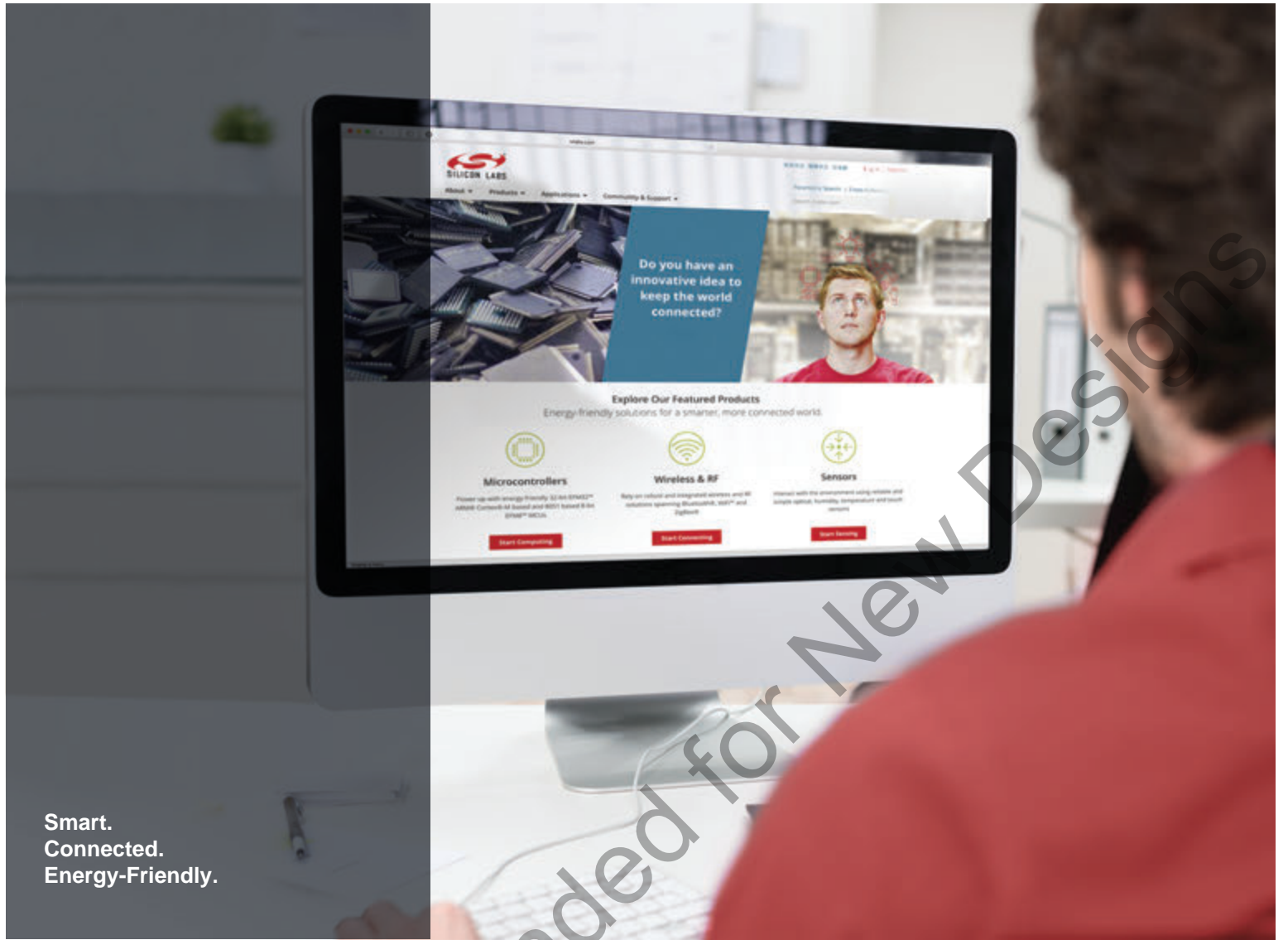

Smart.
Connected.
Energy-Friendly.



Products
www.silabs.com/products

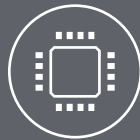

Quality
www.silabs.com/quality



Support and Community
community.silabs.com

Disclaimer

Silicon Laboratories intends to provide customers with the latest, accurate, and in-depth documentation of all peripherals and modules available for system and software implementers using or intending to use the Silicon Laboratories products. Characterization data, available modules and peripherals, memory sizes and memory addresses refer to each specific device, and "Typical" parameters provided can and do vary in different applications. Application examples described herein are for illustrative purposes only. Silicon Laboratories reserves the right to make changes without further notice and limitation to product information, specifications, and descriptions herein, and does not give warranties as to the accuracy or completeness of the included information. Silicon Laboratories shall have no liability for the consequences of use of the information supplied herein. This document does not imply or express copyright licenses granted hereunder to design or fabricate any integrated circuits. The products are not designed or authorized to be used within any Life Support System without the specific written consent of Silicon Laboratories. A "Life Support System" is any product or system intended to support or sustain life and/or health, which, if it fails, can be reasonably expected to result in significant personal injury or death. Silicon Laboratories products are not designed or authorized for military applications. Silicon Laboratories products shall under no circumstances be used in weapons of mass destruction including (but not limited to) nuclear, biological or chemical weapons, or missiles capable of delivering such weapons.

Trademark Information

Silicon Laboratories Inc.®, Silicon Laboratories®, Silicon Labs®, SiLabs® and the Silicon Labs logo®, Bluegiga®, Bluegiga Logo®, Clockbuilder®, CMEMS®, DSPLL®, EFM®, EFM32®, EFR®, Ember®, Energy Micro, Energy Micro logo and combinations thereof, "the world's most energy friendly microcontrollers", Ember®, EZLink®, EZRadio®, EZRadioPRO®, Gecko®, ISOModem®, Precision32®, ProSLIC®, Simplicity Studio®, SiPHY®, Telegesis, the Telegesis Logo®, USBXpress® and others are trademarks or registered trademarks of Silicon Laboratories Inc. ARM, CORTEX, Cortex-M3 and THUMB are trademarks or registered trademarks of ARM Holdings. Keil is a registered trademark of ARM Limited. All other products or brand names mentioned herein are trademarks of their respective holders.



SILICON LABS

Silicon Laboratories Inc.
400 West Cesar Chavez
Austin, TX 78701
USA

<http://www.silabs.com>

Looking for pricing, stock, or lifecycle information?

Click below to explore more details on WIN SOURCE:

 [View SI7034-A10-IM on WIN SOURCE](#)

 [Silicon Labs](#) Information

Optimize Your Supply Chain with WIN SOURCE Solutions

-  Global Sourcing Solution
-  Obsolete Management
-  Cost Control Management
-  Shortage Management
-  Alternative Solution
-  Excess Inventory Management