



**THE DATASHEET OF
SI7015-A20-GM**



DIGITAL I²C HUMIDITY AND TEMPERATURE SENSOR

Features

- Precision Relative Humidity Sensor
 - ± 4.5% RH (max), 0–80% RH
- High-Accuracy Temperature Sensor
 - ±1 °C (max), –10 to 85 °C
- 0 to 100% RH operating range
- 0 to +70 °C operating range (FM)
- –40 to +85 °C operating range (GM)
- Low Voltage Operation (1.9 to 3.6 V)
- Low Power Consumption
 - 150 µA active current
 - 60 nA standby current
- Drop-In Upgrade for Si7005
- Factory-calibrated
- I²C Interface
- Integrated on-chip heater
- 4x4 mm QFN package
- Excellent long term stability
- Optional factory-installed cover
 - Low-profile
 - Protection during reflow
 - Excludes liquids and particulates



Ordering Information

See page 31.

Patent protected; patents pending

Applications

- HVAC/R
- Thermostats/humidistats
- Instrumentation
- White goods
- Micro-environments/data centers
- Industrial controls
- Weather stations
- Asset tracking and storage

Description

The Si7015 I²C Humidity and Temperature Sensor is a monolithic CMOS IC integrating humidity and temperature sensor elements, an analog-to-digital converter, signal processing, calibration data, and an I²C Interface. The patented use of industry-standard, low-K polymeric dielectrics for sensing humidity enables the construction of low-power, monolithic CMOS Sensor ICs with low drift and hysteresis and excellent long term stability.

Each unit is factory-calibrated, and the calibration data is stored in the on-chip non-volatile memory. This ensures that the sensors are fully interchangeable, with no recalibration or software changes required. The Si7015 can be used as a drop-in upgrade for the Si7005 with only minor software changes because the register sets are the same, and the 4x4 mm QFN package is footprint-compatible with that of the Si7005.

The device is compatible with standard SMT assembly processes, such as reflow. The optional factory-installed cover offers a low profile and convenient means of protecting the sensor during assembly (e.g., reflow soldering) and throughout the life of the product, excluding liquids (hydrophobic/oleophobic) and particulates.

The Si7015 offers an accurate, low-power, factory-calibrated digital solution ideal for measuring humidity, dew-point, and temperature in applications ranging from HVAC/R and asset tracking to industrial and consumer platforms.

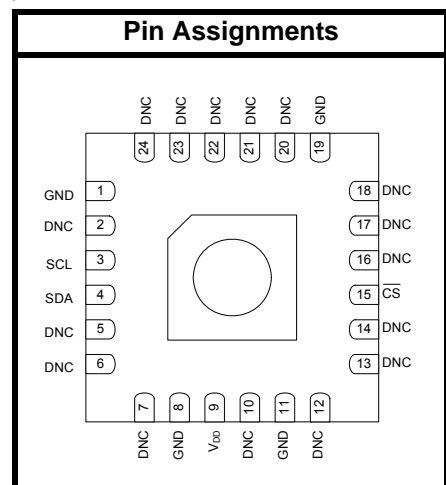

Si7015-A20

Functional Block Diagram

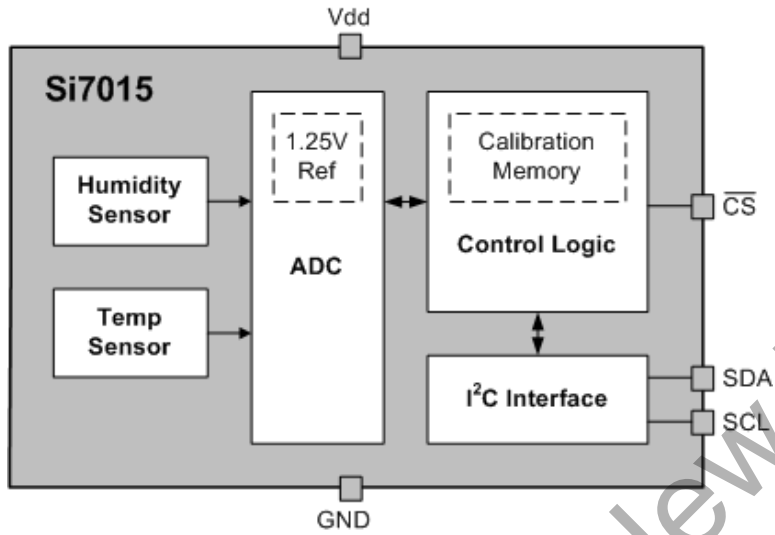

Not Recommended for New Designs

TABLE OF CONTENTS

<u>Section</u>	<u>Page</u>
1. Electrical Specifications	4
2. Typical Application Circuit	10
3. Bill of Materials	11
4. Functional Description	12
4.1. Overview	12
4.2. Relative Humidity Sensor Accuracy	13
4.3. Temperature Compensation	14
4.4. Hysteresis	14
4.5. Prolonged Exposure to High Humidity	14
4.6. PCB Assembly	15
4.7. Protecting the Sensor	17
4.8. Bake/Hydrate Procedure	17
4.9. Long Term Drift/Aging	17
5. Host Interface	18
5.1. I2C Interface	18
5.2. I2C Operation	23
6. Control Registers	26
6.1. Register Detail	26
7. Pin Descriptions: Si7015	30
8. Ordering Guide	31
9. Package Outline	32
9.1. 24-Pin QFN	32
9.2. 24-Pin QFN with Protective Cover	33
10. PCB Land Pattern and Solder Mask Design	34
11. Top Marking	36
11.1. Si7015 Top Marking	36
11.2. Top Marking Explanation	36
12. Additional Reference Resources	37
Contact Information	38

Si7015-A20

1. Electrical Specifications

Unless otherwise specified, all min/max specifications apply over the recommended operating conditions.

Table 1. Recommended Operating Conditions

Parameter	Symbol	Test Condition	Min	Typ	Max	Unit
Power Supply	V _{DD}		1.9	—	3.6	V
Operating Temperature	T _A	F grade	0	—	+70	°C
Operating Temperature	T _A	G grade	-40	—	+85	°C

Table 2. General Specifications

1.9 ≤ V_{DD} ≤ 3.6 V; T_A = -40 to 85 °C (G grade) or 0 to 70 °C (F grade); default conversion time unless otherwise noted.

Parameter	Symbol	Test Condition ¹	Min	Typ	Max	Unit
Input Voltage High	V _{IH}	AD0, SCL, SDA pins	0.7xV _{DD}	—	—	V
Input Voltage Low	V _{IL}	AD0, SCL, SDA pins	—	—	0.3xV _{DD}	V
Input Voltage Range	V _{IN}	SCL, SDA, RSTb pins with respect to GND	0.0	—	V _{DD}	V
Input Leakage	I _{IL}	SCL, SDA pins; V _{IN} = GND	—	—	1	μA
		\overline{CS} pin (200K nominal pull up); V _{in} = GND	5xV _{DD}			μA
Output Voltage Low	V _{OL}	SDA pin; I _{OL} = 2.5 mA; V _{DD} = 3.3 V	—	—	0.6	V
		SDA pin; I _{OL} = 1.2 mA; V _{DD} = 1.9 V	—	—	0.4	V
Current Consumption	I _{DD}	RH conversion in progress	—	150	180	μA
		Temperature conversion in progress	—	90	120	μA
		$\overline{CS} < V_{IL}$; no conversion in progress; V _{DD} = 3.3 V; SDA = SCL ≥ V _{IH} ; HEAT = 1	—	24	—	mA
		Standby ² , -40 to +85 °C	—	0.06	0.62	μA
		Peak I _{DD} during powerup ³	—	3.5	4.0	mA
		Peak I _{DD} during I ² C operations ⁴	—	3.5	4.0	mA
Conversion Time	t _{CONV}	RH Normal (Fast = 0)	—	5.8	7.0	ms
		RH Fast (Fast = 1)	—	2.6	3.1	ms
		Temperature Normal (Fast = 0)	—	4.0	6.2	ms
		Temperature Fast (Fast = 1)	—	1.5	2.4	ms

Notes:

1. Initiating a RH measurement will also automatically initiate a temperature measurement. The total conversion time will be t_{CONV}(RH) + t_{CONV}(T).
2. No conversion or I²C transaction in progress. Typical values measured at 25 °C.
3. Occurs once during powerup. Duration is <5 msec.
4. Occurs during I²C commands for Read Device ID and Read Firmware Version. Duration is < 100 μs when I²C clock speed is >100 kHz.

Table 2. General Specifications (Continued)

$1.9 \leq V_{DD} \leq 3.6$ V; $T_A = -40$ to 85 °C (G grade) or 0 to 70 °C (F grade); default conversion time unless otherwise noted.

Parameter	Symbol	Test Condition ¹	Min	Typ	Max	Unit
Wake Up Time	t_{CS}	From $\overline{CS} < V_{IL}$ to ready for a temp/RH conversion	—	—	1	ms
Power Up Time	t_{PU}	From $V_{DD} \geq 1.9$ V to ready for a temp/RH conversion, 25°C	—	18	25	ms
		From $V_{DD} \geq 1.9$ V to ready for a temp/RH conversion, full temperature range	—	—	80	ms

Notes:

1. Initiating a RH measurement will also automatically initiate a temperature measurement. The total conversion time will be $t_{CONV(RH)} + t_{CONV(T)}$.
2. No conversion or I²C transaction in progress. Typical values measured at 25 °C.
3. Occurs once during powerup. Duration is <5 msec.
4. Occurs during I²C commands for Read Device ID and Read Firmware Version. Duration is <100 μs when I²C clock speed is >100 kHz.

Table 3. I²C Interface Specifications¹

$1.9 \leq V_{DD} \leq 3.6$ V; $T_A = 0$ to 70 °C (F grade) or -40 to $+85$ °C (G grade) unless otherwise noted.

Parameter	Symbol	Test Condition	Min	Typ	Max	Unit
Hysteresis	V_{HYS}	High-to-low versus low-to-high transition	$0.05 \times V_{DD}$	—	—	V
SCLK Frequency	f_{SCL}		—	—	400	kHz
SCL High Time	t_{SKH}		0.6	—	—	μs
SCL Low Time	t_{SKL}		1.3	—	—	μs
Start Hold Time	t_{STH}		0.6	—	—	μs
Start Setup Time	t_{STS}		0.6	—	—	μs
Stop Setup Time	t_{SPS}		0.6	—	—	μs
Bus Free Time	t_{BUF}	Between Stop and Start	1.3	—	—	μs
SDA Setup Time	t_{DS}		100	—	—	ns
SDA Hold Time	t_{DH}		100	—	—	ns
SDA Valid Time	$t_{VD;DAT}$	From SCL low to data valid	—	—	0.9	μs
SDA Acknowledge Valid Time	$t_{VD;ACK}$	From SCL low to data valid	—	—	0.9	μs
Suppressed Pulse Width ²	t_{SP}		50	—	—	ns

Notes:

1. All values are referenced to V_{IL} and/or V_{IH} .
2. Pulses up to and including 50ns will be suppressed.

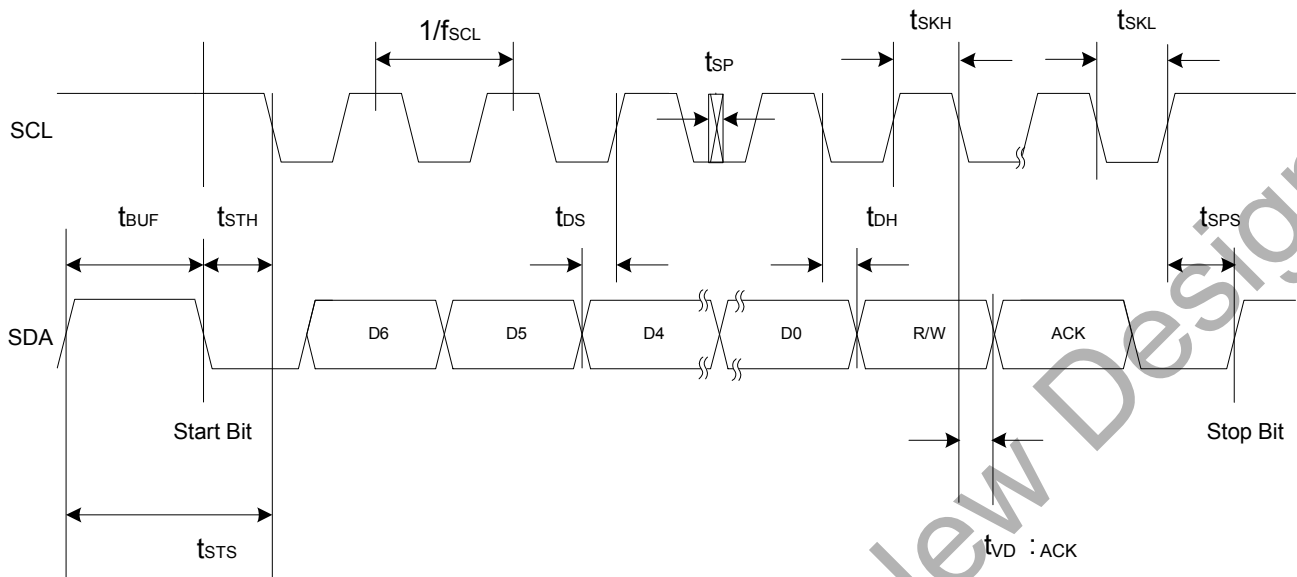

Figure 1. I²C Interface Timing Diagram

Table 4. Humidity Sensor

$1.9 \leq V_{DD} \leq 3.6 \text{ V}$; $T_A = 30 \text{ }^\circ\text{C}$; default conversion time unless otherwise noted.

Parameter	Symbol	Test Condition	Min	Typ	Max	Unit
Operating Range ¹		Non-condensing	0	—	100	%RH
Accuracy ^{2, 3}		0 – 80% RH	—	±3.0	±4.5	%RH
		80 – 100% RH	See Figure 2.			%RH
Repeatability/Noise		Normal Mode	—	0.05	—	%RH RMS
		Fast Mode	—	0.2	—	%RH RMS
Response Time ⁴	$T_{63\%}$	1 m/s airflow, with cover	—	18	—	S
		1 m/s airflow, without cover	—	17	—	
Drift vs. Temperature			—	0.05	—	%RH/°C
Hysteresis			—	±1	—	%RH
Long Term Stability ³			—	≤ 0.25	—	%RH/yr

Notes:

1. Recommended humidity operating range is 20% to 80% RH (non-condensing) over $-10 \text{ }^\circ\text{C}$ to $60 \text{ }^\circ\text{C}$. Prolonged operation beyond these ranges may result in a shift of sensor reading with slow recovery time.
2. Excludes hysteresis, long term drift, and certain other factors and is applicable to non-condensing environments only. See Section “4.2. Relative Humidity Sensor Accuracy” for more details.
3. Drift due to aging effects at typical room conditions of $30 \text{ }^\circ\text{C}$ and 30% to 50%. May be impacted by dust, vaporized solvents or other contaminants, e.g., out-gassing tapes, adhesives, packaging materials, etc. See Section “4.9. Long Term Drift/Aging”.
4. Response time to a step change in RH. Time for the RH output to change by 63% of the total RH change.

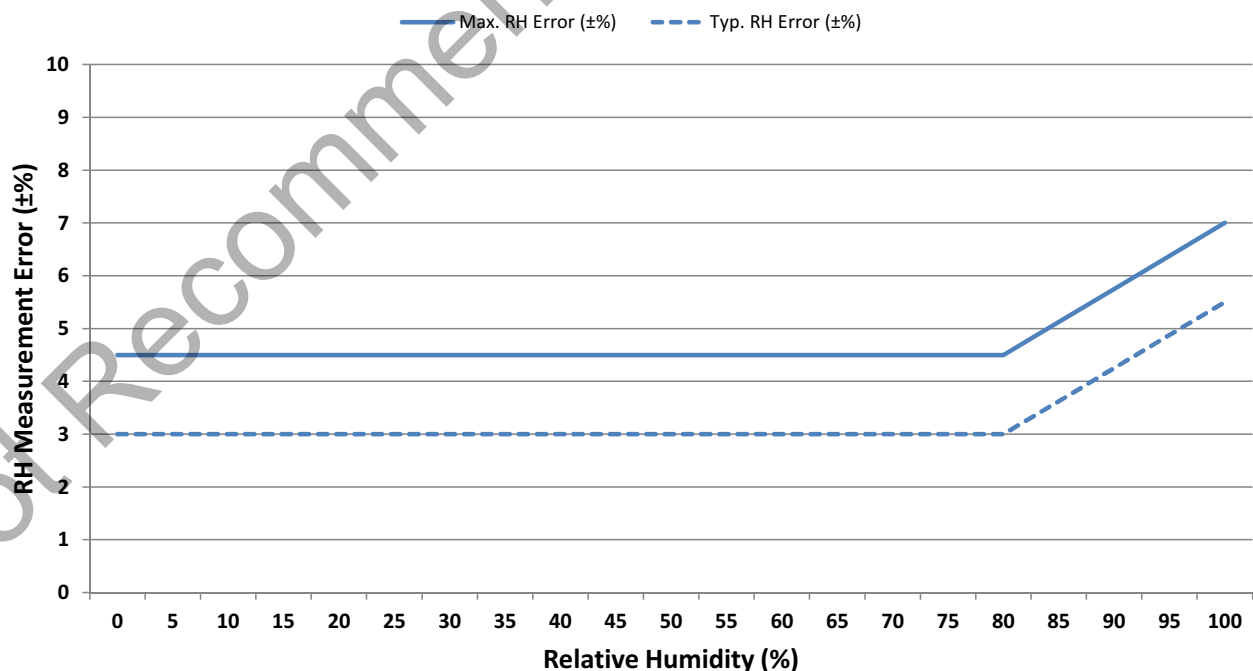
RH Accuracy**Figure 2. RH Accuracy at 30 °C**

Si7015-A20

Table 5. Temperature Sensor

$1.9 \leq V_{DD} \leq 3.6$ V; $T_A = -40$ to $+85$ °C (G grade) or 0 to $+70$ °C (F grade), default conversion time unless otherwise noted.

Parameter	Symbol	Test Condition	Min	Typ	Max	Unit
Operating Range		F Grade	0	—	+70	°C
		G Grade	-40	—	+85	°C
Accuracy ¹		$0\text{ °C} \leq t_A \leq 70\text{ °C}$	—	±0.5	±1.0	°C
		$-40\text{ °C} \leq t_A \leq 85\text{ °C}$	Figure 3.			°C
Repeatability/Noise		Normal Mode	—	0.02	—	°C RMS
		Fast Mode	—	0.08	—	°C RMS
Response Time ²	$T_{63\%}$	Unmounted device	—	0.7	—	s
		Si7015-EB board	—	5.1	—	s
Long Term Stability			—	≤ 0.01	—	°C/Yr

Notes:

- 14b measurement resolution (default).
- Time to reach 63% of final value in response to a step change in temperature. Actual response time will vary dependent on system thermal mass and air-flow.

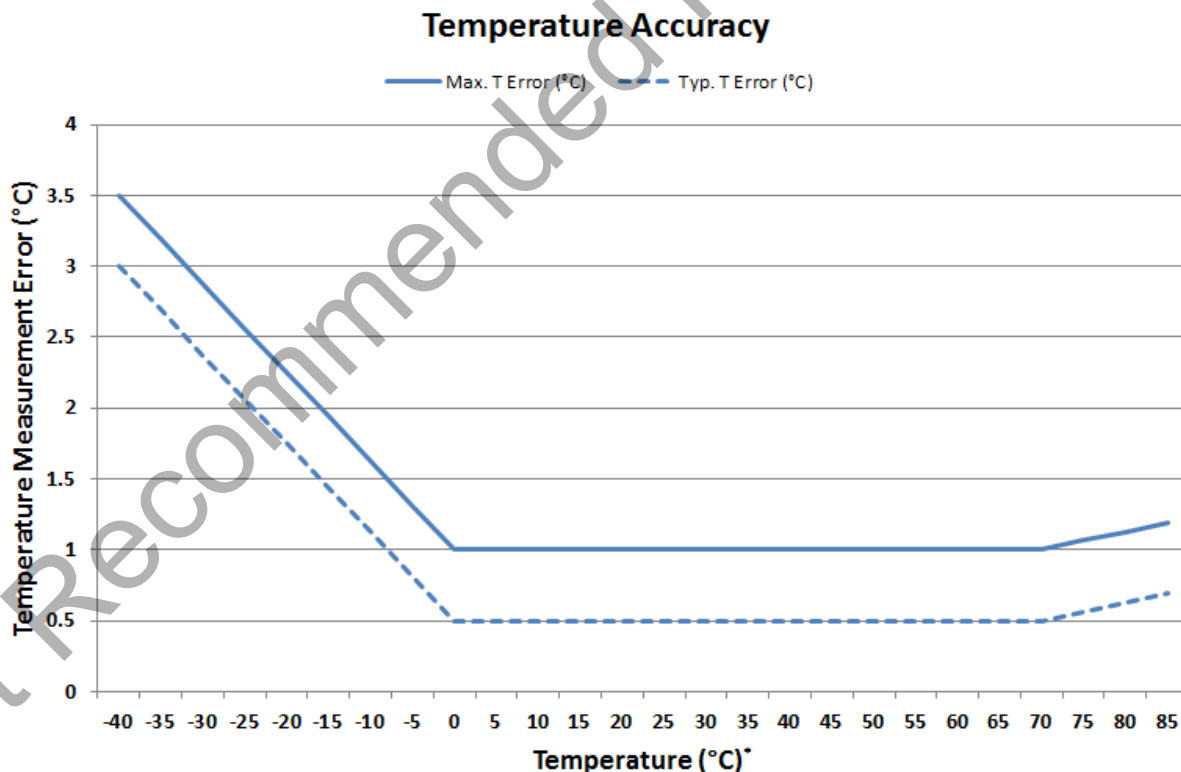

Figure 3. Temperature Accuracy*

Note: Figure 3 only applies to G-grade devices beyond 70° C.

Table 6. Thermal Characteristics

Parameter	Symbol	Test Condition	QFN-24	Unit
Junction-to-Air Thermal Resistance	θ_{JA}	JEDEC 4-layer board	55	°C/W
Junction-to-Air Thermal Resistance	θ_{JA}	2-layer evaluation PCB with minimal thermal pad	110	°C/W

Table 7. Absolute Maximum Ratings^{1,2}

Parameter	Symbol	Test Condition	Min	Typ	Max	Unit
Ambient Temperature under Bias			-55	—	125	°C
Storage Temperature			-65	—	150	°C
Voltage on SDA or SCL Pin with Respect to GND			-0.3	—	$V_{DD} + 0.3$	V
Voltage on \overline{CS} pin with Respect to GND			-0.3	—	$V_{DD} + 0.3$	V
Voltage on V_{DD} with Respect to GND			-0.3	—	4.2	V
ESD Tolerance		HBM	—	—	2	kV
		CDM	—	—	1.25	kV
		MM	—	—	250	V
Notes:						
1. Absolute maximum ratings are stress ratings only; operation at or beyond these conditions is not implied and may shorten the life of the device or alter its performance.						
2. Special handling considerations apply; see "AN607: Si70xx Humidity Sensor Designer's Guide" for details.						

Si7015-A20

2. Typical Application Circuit

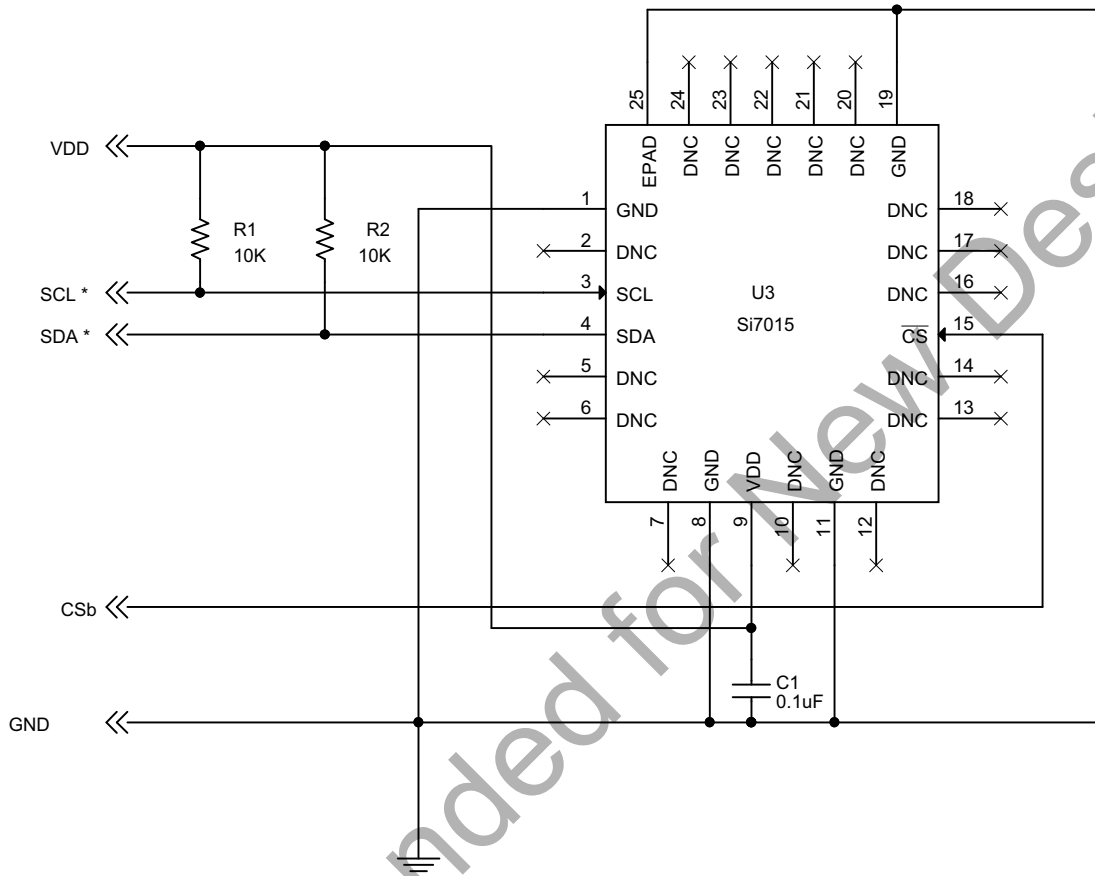

Figure 4. Typical Application Circuit*

*Note: If Si7015 is replacing an Si7005, the capacitor connected to Pin 10 may be left connected or removed.

3. Bill of Materials

Table 8. Typical Application Circuit BOM*

Reference	Description	Mfr Part Number	Manufacturer
C1	Capacitor, 0.1 μ F, 6.3 V, X7R, 0603	C0603X7R6R3-104M	Venkel
R1*	Resistor, 10 k Ω , \pm 5%, 1/16 W, 0603	CR0603-16W-1002J	Venkel
R2*	Resistor, 10 k Ω , \pm 5%, 1/16 W, 0603	CR0603-16W-1002J	Venkel
U1	IC, digital temperature/humidity sensor	Si7015-A20	Silicon Labs

*Note: Typical value shown. Optimal value depends on bus capacitance and speed of bus operation; not needed if present elsewhere in the system.

4. Functional Description

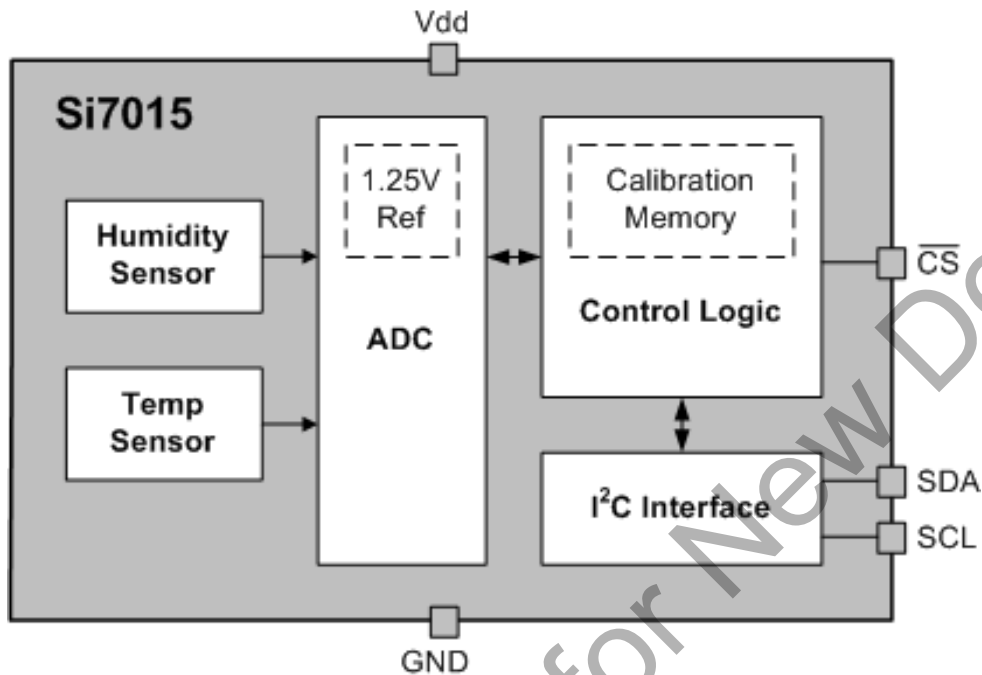

Figure 5. Si7015 Functional Block Diagram

4.1. Overview

The Si7015 is a digital relative humidity and temperature sensor. This monolithic CMOS IC integrates temperature and humidity sensor elements, an analog-to-digital converter, signal processing, calibration data, and an I²C host interface. Both the temperature and humidity sensors on each unit are factory-calibrated and the calibration data is stored in the on-chip non-volatile memory. This ensures that the sensors are fully interchangeable, with no recalibration or software changes required.

While the Si7015 is largely a conventional mixed-signal CMOS integrated circuit, relative humidity sensors in general and those based on capacitive sensing using polymeric dielectric have unique application and use requirements that are not common to conventional (non-sensor) ICs. Chief among those are:

- The need to protect the sensor during board assembly, i.e., solder reflow, and the need to subsequently rehydrate the sensor.
- The need to apply temperature correction to the humidity readings.
- The need to protect the sensor from damage or contamination during the product life-cycle.
- The impact of prolonged exposure to extremes of temperature and/or humidity and their potential effect on sensor accuracy.
- The effects of humidity sensor “memory”.

Each of these items is discussed in more detail in the following sections.

4.2. Relative Humidity Sensor Accuracy

To determine the accuracy of a relative humidity sensor, it is placed in a temperature and humidity controlled chamber. The temperature is set to a convenient fixed value (typically 30 °C) and the relative humidity is swept from 20 to 80% and back to 20% in the following steps: 20% – 40% – 60% – 80% – 80% – 60% – 40% – 20%. At each set-point, the chamber is allowed to settle for a period of 60 minutes before a reading is taken from the sensor. Prior to the sweep, the device is allowed to stabilize to 50%RH. The solid top and bottom trace in Figure 6, “Measuring Sensor Accuracy Including Hysteresis,” shows the result of a typical sweep after non-linearity compensation.

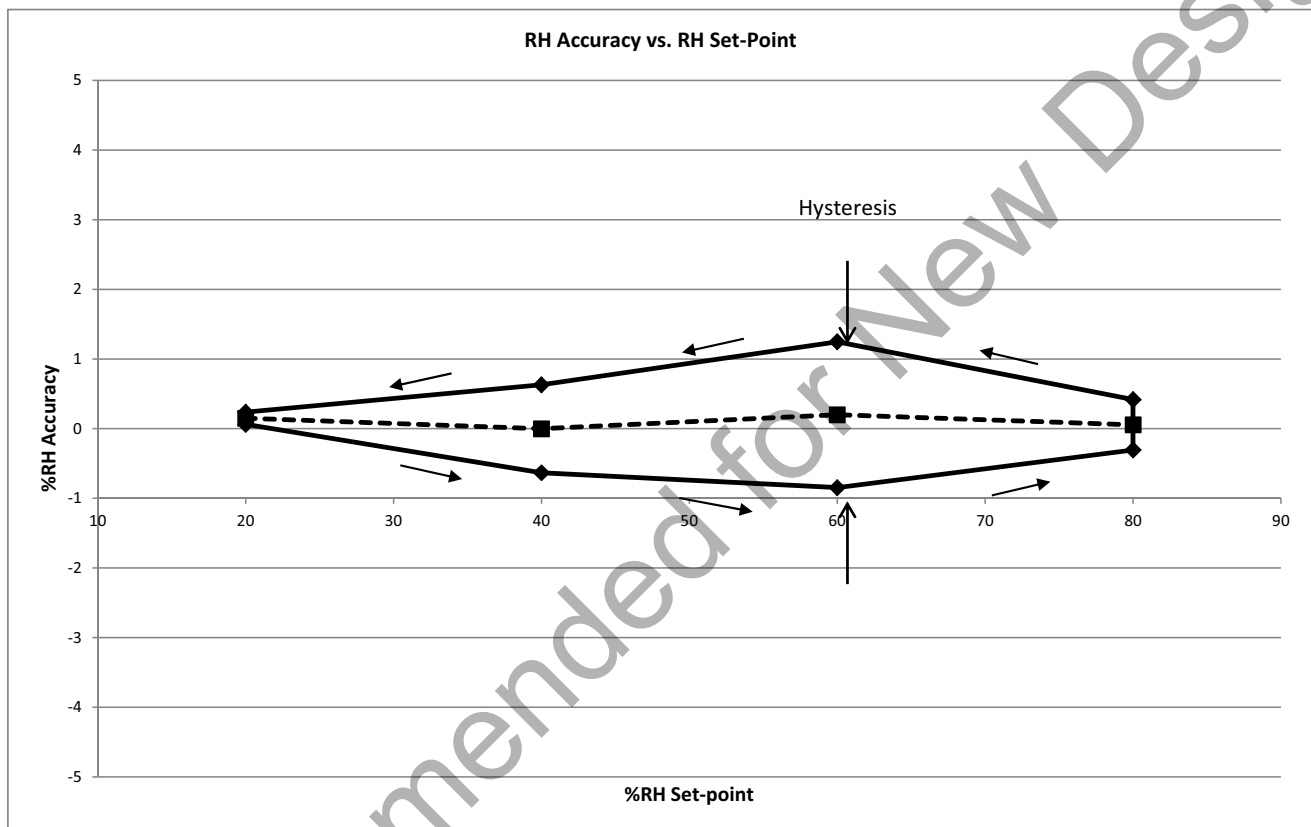

Figure 6. Measuring Sensor Accuracy Including Hysteresis

The RH accuracy is defined as the center (dashed) line shown in Figure 6, which is the average of the two data points at each relative humidity set-point. In this case, the sensor shows an accuracy of 0.25%RH. The Si7015 accuracy specification (Table 4) includes the following:

- Unit-to-unit and lot-to-lot variation in non-linearity compensation
- Accuracy of factory calibration
- Margin for shifts that can occur during solder reflow.

The accuracy specification does not include the following:

- Hysteresis (typically $\pm 1\%$)
- Effects from long term exposure to very humid conditions
- Contamination of the sensor by particulates, chemicals, etc.
- Other aging related shifts (“Long-term stability”)
- Variations due to temperature

4.3. Temperature Compensation

The Si7015 relative humidity sensor is calibrated at a temperature of 30 °C; it is at this temperature that the sensor will give the most accurate relative humidity readings. For relative humidity measurements at other temperatures, the RH reading from the Si7015 must be compensated for the change in temperature relative to 30 °C. Temperature-compensated relative humidity readings can be calculated as follows:

$$RH_{TempCompensated} = RH_{Linear} + (Temperature - 30) \times (RH_{Linear} \times Q_1 + Q_0)$$

Where:

- $RH_{TempCompensated}$ is the temperature compensated relative humidity value in %RH.
- RH_{Linear} is the linear corrected relative humidity value in %RH.
- Temperature is the ambient temperature in °C as measured by the Si7015 on chip temperature sensor.
- Q_1 and Q_0 are unit-less correction coefficients derived through characterization of Si7015s by Silicon Laboratories.

This temperature compensation is most accurate in the range of 15–50 °C. The values for the correction coefficients are shown in Table 9.

Table 9. Linearization Coefficients

Coefficient	Value
Q_0	0.060162
Q_1	0.000508

4.4. Hysteresis

The moisture absorbent film (polymeric dielectric) of the humidity sensor will carry a memory of its exposure history, particularly its recent or extreme exposure history. A sensor exposed to relatively low humidity will carry a negative offset relative to the factory calibration, and a sensor exposed to relatively high humidity will carry a positive offset relative to the factory calibration. This factor causes a hysteresis effect illustrated by the solid top and bottom traces in Figure 6. The hysteresis value is the difference in %RH between the maximum absolute error on the decreasing humidity ramp and the maximum absolute error on the increasing humidity ramp at a single relative humidity Setpoint and is expressed as a bipolar quantity relative to the average, the center dashed trace in Figure 6. In the case of Figure 6, the measurement uncertainty due to the hysteresis effect is $\pm 1.05\%$ RH.

4.5. Prolonged Exposure to High Humidity

Prolonged exposure to high humidity will result in a gradual upward drift of the RH reading. The shift in sensor reading resulting from this drift will generally disappear slowly under normal ambient conditions. The amount of shift is proportional to the magnitude of relative humidity and the length of exposure. In the case of lengthy exposure to high humidity, some of the resulting shift may persist indefinitely under typical conditions. It is generally possible to substantially reverse this affect by baking the device (see Section “4.8. Bake/Hydrate Procedure”).

4.6. PCB Assembly

4.6.1. Soldering

Like most ICs, Si7015 devices are shipped from the factory vacuum-packed with an enclosed desiccant to avoid any drift during storage and to prevent any moisture-related issues during solder reflow. The following guidelines should be observed during PCB assembly:

- Si7015 devices are compatible with standard board assembly processes. Devices should be soldered using reflow per the recommended card reflow profile. See Section “10. PCB Land Pattern and Solder Mask Design” for the recommended card reflow profile.
- A “no clean” solder process is recommended to minimize the need for water or solvent rinses after soldering. Cleaning after soldering is possible, but must be done carefully to avoid impacting the performance of the sensor. See application note, “AN607: Si70xx Humidity Sensor Designer’s Guide” for more information on cleaning.
- It is essential that the exposed polymer sensing film be kept clean and undamaged. This can be accomplished by careful handling and a clean, well-controlled assembly process. When in doubt or for extra protection, a heat-resistant, protective cover such as Kapton® KPPD-1/8 can be installed during PCB assembly.

Si7015s may be ordered with a factory-fitted, solder-resistant protective cover. This cover provides protection during PCB assembly or rework but without the time and effort required to install and remove the Kapton® tape. It can be left in place for the lifetime of the product, preventing liquids, dust, or other contaminants from coming into contact with the polymer sensor film. See Section “8. Ordering Guide” for a list of ordering part numbers that include the cover.

4.6.2. Rehydration

The measured humidity value will generally shift slightly after solder reflow. A portion of this shift is permanent and is accounted for in the accuracy specifications in Table 4. After soldering, an Si7015 should be allowed to equilibrate under controlled RH conditions (room temperature, 45-55%RH) for at least 48 hours to eliminate the remainder of the shift and return the device to its specified accuracy performance.

4.6.3. Rework

To maintain the specified sensor performance, care must be taken during rework to minimize the exposure of the device to excessive heat and to avoid damage/contamination or a shift in the sensor reading due to liquids, solder flux, etc. Manual touch-up using a soldering iron is permissible under the following guidelines:

- The exposed polymer sensing film must be kept clean and undamaged. A protective cover is recommended during any rework operation (Kapton[®] tape or the factory-installed cover).
- Flux must not be allowed to contaminate the sensor; liquid flux is not recommended even with a cover in place. Conventional lead-free solder with rosin core is acceptable for touch-up as long as a cover is in place during the rework.
- If possible, avoid water or solvent rinses after touch-up. Cleaning after soldering is possible, but must be done carefully to avoid impacting the performance of the sensor. See application note, “AN607: Si70xx Humidity Sensor Designer’s Guide” for more information on cleaning.
- Minimize the heating of the device. Soldering iron temperature should not exceed 350 °C and the contact time per pin should not exceed five seconds.
- Hot air rework is not recommended. If a device must be replaced, remove the device by hot air and solder a new part in its place by reflow following the guidelines above.

***Note:** All trademarks are the property of their respective owners.

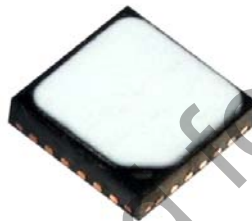

Figure 7. Si7015 with Factory-Installed Protective Cover

4.7. Protecting the Sensor

Because the sensor operates on the principal of measuring a change in capacitance, any changes to the dielectric constant of the polymer film will be detected as a change in relative humidity. Therefore, it is important to minimize the probability of contaminants coming into contact with the sensor. Dust and other particles as well as liquids can affect the RH reading. It is recommended that a cover is employed in the end system that blocks contaminants but allows water vapor to pass through. Depending on the needs of the application, this can be as simple as plastic or metallic gauze for basic protection against particulates or something more sophisticated such as a hydrophobic membrane providing up to IP67 compliant protection.

The Si7015 may be ordered with a factory-fitted, solder-resistant cover that can be left in place for the lifetime of the product. It is very low-profile, hydrophobic and oleophobic. See Section “8. Ordering Guide” for a list of ordering part numbers that include the cover. A dimensioned drawing of the IC with the cover is included in Section “9. Package Outline”. Other characteristics of the cover are listed in Table 10.

Table 10. Specifications of Protective Cover

Parameter	Value
Material	PTFE
Operating Temperature	-40 to +125 °C
Maximum Reflow Temperature	260 °C
IP Rating (per IEC 529)	IP67

4.8. Bake/Hydrate Procedure

After exposure to extremes of temperature and/or humidity for prolonged periods, the polymer sensor film can become either very dry or very wet; in each case the result is either high or low relative humidity readings. Under normal operating conditions, the induced error will diminish over time. From a very dry condition, such as after shipment and soldering, the error will diminish over a few days at typical controlled ambient conditions, e.g., 48 hours of $45 \leq \%RH \leq 55$. However, from a very wet condition, recovery may take significantly longer. To accelerate recovery from a wet condition, a bake and hydrate cycle can be implemented. This operation consists of the following steps:

- Baking the sensor at 125 °C for ≥ 12 hours
- Hydration at 30 °C in 75 %RH for ≥ 10 hours

Following this cycle, the sensor will return to normal operation in typical ambient conditions after a few days.

4.9. Long Term Drift/Aging

Over long periods of time, the sensor readings may drift due to aging of the device. Standard accelerated life testing of the Si7015 has resulted in the specifications for long-term drift shown in Table 4 and Table 5. This contribution to the overall sensor accuracy accounts only for the long-term aging of the device in an otherwise benign operating environment and does not include the affects of damage, contamination, or exposure to extreme environmental conditions.

5. Host Interface

5.1. I²C Interface

The Si7015 has an I²C serial interface with a 7-bit address of 0x40. The Si7015 is a slave device supporting data transfer rates up to 400 kHz. Table 20 shows the register summary of the Si7015.

5.1.1. Performing a Relative Humidity Measurement

The following steps should be performed in sequence to take a relative humidity measurement:

1. Set START (D0) in CONFIG to begin a new conversion.
2. Poll RDY (D0) in STATUS (register 0) until it is low (= 0). (This must be done at least once prior to reading results even if the host waits longer than t_{CONV}.)
3. Read the upper and lower bytes of the RH value from DATAh and DATAl (registers 0x01 and 0x02), respectively. Table 11 shows the format of the 12-bit relative humidity result.
4. Convert the RH value to %RH using the following equation:

$$\%RH = \left(\frac{RH}{16} \right) - 24$$

where RH is the measured value returned in DATAh:DATAI.

5. Apply temperature compensation as discussed elsewhere in this data sheet.

Due to normal variations in RH accuracy of the device as described in Table 4, it is possible for the measured value of %RH to be slightly less than 0 when the actual RH level is close to or equal to 0. Similarly, the measured value of %RH may be slightly greater than 100 when the actual RH level is close to or equal to 100. This is expected behavior, and it is acceptable to limit the range of RH results to 0 to 100%RH in the host software by truncating values that are slightly outside of this range.

Table 12 shows the 12-bit values that correspond to various measured RH levels.

Table 11. 12-Bit Relative Humidity Result Available in Registers 1 and 2

DATAh								DATAI							
D7	D6	D5	D4	D3	D2	D1	D0	D7	D6	D5	D4	D3	D2	D1	D0
12-Bit Relative Humidity Code															

Table 12. Typical %RH Measurement Codes for 0 to 100% RH Range

%RH	12 Bit Code	
	Dec	Hex
0	384	180
10	544	220
20	704	2C0
30	864	360
40	1024	400
50	1184	4A0
60	1344	540
70	1504	5E0
80	1664	680
90	1824	720
100	1984	7C0

The above sequence assumes normal mode, i.e., $t_{\text{CONV}} = 5.8$ ms (typical). Conversions may be performed in fast mode. See Section "5.1.4. Fast Conversion Mode".

5.1.2. Performing a Temperature Measurement

The following steps should be performed in sequence to take a temperature measurement:

1. Set START (D0) and TEMP (D4) in CONFIG (register 0x03) to begin a new conversion, i.e., write CONFIG with 0x11
2. Poll RDY (D0) in STATUS (register 0) until it is low (=0). This must be done at least once prior to reading results even if the host waits longer than t_{CONV} .
3. Read the upper and lower bytes of the temperature value from DATAh and DATAl (registers 0x01 and 0x02), respectively

Table 13 shows the format of the 14-bit temperature result. This value may be converted to °C using the following equation:

$$\text{Temperature}(^{\circ}\text{C}) = \left(\frac{\text{TEMP}}{32} \right) - 50$$

where TEMP is the measured value returned in DATAh:DATAI.

Table 14 shows the 14-bit values that correspond to various measured temperature levels.

Table 13. 14-Bit Temperature Result Available in Registers 1 and 2

DATAh								DATAI							
D7	D6	D5	D4	D3	D2	D1	D0	D7	D6	D5	D4	D3	D2	D1	D0
14-Bit Temperature Code															

The above sequence assumes normal mode, i.e., $t_{CONV} = 5.8$ ms (typical). Conversions may be performed in fast mode. See Section “5.1.4. Fast Conversion Mode”.

5.1.3. Entering Low-Power Mode

Either of the following sequences can be used to place the Si7015 into its low-power standby mode following an RH conversion:

Option A:

Bring CSb high. This puts the Si7015 in low-power mode and disables I²C communication. This is similar to Si7005 except that the response to CSb high takes only a few usec and the V_{DD} current is $<1 \mu\text{A}$ (as opposed to Si7005 which can take >1 second and can have V_{DD} current of up to $100 \mu\text{A}$).

Option B:

1. Poll /RDY until it returns zero, indicating that the conversion is finished.
2. Read the results of the RH conversion from DATAh:DATAI.
3. Clear the start bit (START) by writing 0x0 to register 3.
4. Clear the start bit (START) a second time by again writing 0x0 to register 3.

The Si7015 does enter its low-power standby mode following a temperature conversion. No action is required in this case. However, please note that doing a temperature conversion following an RH conversion will not put the Si7015 in low power state.

Table 14. Typical Temperature Measurement Codes for the -40 °C to 100 °C Range

Temp(°C)	14 Bit Code	
	Dec	Hex
-40	320	0140
-30	640	0280
-20	960	03C0
-10	1280	0500
0	1600	0640
10	1920	0780
20	2240	08C0
30	2560	0A00
40	2880	0B40
50	3200	0C80
60	3520	0DC0
70	3840	0F00
80	4160	1040
90	4480	1180
100	4800	12C0

5.1.4. Fast Conversion Mode

The time needed to perform a temperature or RH measurement can be reduced from 5.8 ms (typical) to 2.6 ms (typical) by setting FAST (D5) in CONFIG (register 0x03). Fast mode reduces the total power consumed during a conversion or the average power consumed by the Si7015 when making periodic conversions. It also reduces the resolution of the measurements.

5.1.5. Heater

The Si7015 relative humidity sensor contains an integrated, resistive heating element that may be used to raise the temperature of the humidity sensor. This element can be used to drive off condensation or to implement dew-point measurement when the Si7015 is used in conjunction with a separate temperature sensor such as another Si7015.

The heater can be activated by setting HEAT (D1) in CONFIG (register 0x03). Turning on the heater will reduce the tendency of the humidity sensor to accumulate an offset due to “memory” of sustained high humidity conditions. When the heater is enabled, the reading of the on-chip temperature sensor will be affected (increased).

5.1.6. Device Identification

The Si7015 device and its revision level can be determined by reading ID (register 0x11). Table 15 lists the values for the various device revisions and may include revisions not yet in existence.

Table 15. Device ID Revision Values

Device ID Value		Device Type	Revision Level
D[7:4]	D[3:0]		
1111	0000	Si7015	A

5.2. I²C Operation

The format of the address byte is shown in Table 16.

Table 16. I²C Slave Address Byte

A6	A5	A4	A3	A2	A1	A0	R/W
1	0	0	0	0	0	0	1/0

5.2.1. I²C Write Operation

To write to a register on the Si7015, the master should issue a start command (S) followed by the slave address, 0x40. The slave address is followed by a 0 to indicate that the operation is a write. Upon recognizing its slave address, the Si7015 issues an acknowledge (A) by pulling the SDA line low for the high duration of the ninth SCL cycle. The next byte the master places on the bus is the register address pointer, selecting the register on the Si7015 to which the data should be transferred. After the Si7015 acknowledges this byte, the master places a data byte on the bus. This byte will be written to the register selected by the address pointer. The Si7015 will acknowledge the data byte, after which the master issues a Stop command (P). See Table 17.

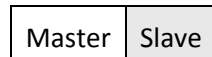

Table 17. I²C Write Sequence

Sequence to Write to a Register

S	Slave Address	W	A	Address Pointer	A	Register Data	A	P
---	---------------	---	---	-----------------	---	---------------	---	---

Sequence to Start a Relative Humidity Conversion

S	0x40	0	A	0x03	A	0x01	A	P
---	------	---	---	------	---	------	---	---

Sequence to Start a Temperature Conversion

S	0x40	0	A	0x03	A	0x11	A	P
---	------	---	---	------	---	------	---	---

Si7015-A20

5.2.2. I²C Read Operation

To read a register on the Si7015, the master must first set the address pointer to indicate the register from which the data is to be transferred. Therefore, the first communication with the Si7015 is a write operation. The master should issue a start command (S) followed by the slave address, 0x40. The slave address is followed by a 0 to indicate that the operation is a write. Upon recognizing its slave address, the Si7015 will issue an acknowledge (A) by pulling the SDA line low for the high duration of the ninth SCL cycle. The next byte the master places on the bus is the register address pointer selecting the register on the Si7015 from which the data should be transferred. After the Si7015 acknowledges this byte, the master issues a repeated start command (Sr) indicating that a new transfer is to take place. The Si7015 is addressed once again with the R/W bit set to 1, indicating a read operation. The Si7015 will acknowledge its slave address and output data from the previously-selected register onto the data bus under the control of the SCL signal, the master should not acknowledge (\bar{A}) the data byte and issue a stop (P) command (see Table 22). However, if a RH or Temperature conversion result (two bytes) is to be read, the master should acknowledge (A) the first data byte and continue to activate the SCL signal. The Si7015 will automatically output the second data byte. Upon receiving the second byte, the master should issue a not Acknowledge (\bar{A}) followed by a stop command. (See Table 23.)

Table 18. I²C Read Sequence for a Single Register

Sequence to Read from a Single Register

S	Slave Address	W	A	Address Pointer	A	Sr	Slave Address	R	A	Register Data	\bar{A}	P
---	---------------	---	---	-----------------	---	----	---------------	---	---	---------------	-----------	---

Sequence to Read Device ID

S	0x40	0	A	0x11	A	Sr	0x40	1	A	ID	\bar{A}	P
---	------	---	---	------	---	----	------	---	---	----	-----------	---

Sequence to Read \overline{RDY} bit

S	0x40	0	A	0x00	A	Sr	0x40	1	A	—	\overline{RDY}	\bar{A}	P
---	------	---	---	------	---	----	------	---	---	---	------------------	-----------	---

Table 19. I²C Read Sequence for RH or Temperature Conversion Result

Sequence to Read Conversion Result

S	Slave Address	W	A	Address Pointer	A	Sr	Slave Address	R	A	Register 1 Data	A	Register 2 Data	\bar{A}	P
---	---------------	---	---	-----------------	---	----	---------------	---	---	-----------------	---	-----------------	-----------	---

S	0x40	0	A	0x01	A	Sr	0x40	1	A	Data H	A	Data L	\bar{A}	P
---	------	---	---	------	---	----	------	---	---	--------	---	--------	-----------	---

5.2.3. Firmware Revision

The internal firmware revision can be read with the following I²C transaction:

S	Slave Address	W	A	0x84	A	0xB8	A	S	Slave Address
---	---------------	---	---	------	---	------	---	---	---------------

R	A	FWREV	A	NA	P
---	---	-------	---	----	---

The values in this field are encoded as follows:

0xFF = Firmware revision 1.0

0x20 = Firmware revision 2.0

Si7015-A20

6. Control Registers

Table 20 contains a summary of the Si7015 register set. Each register is described in more detail below.

Table 20. Si7015 Register Summary

Register	Name	Bit 7	Bit 6	Bit 5	Bit 4	Bit 3	Bit 2	Bit 1	Bit 0
I ² C Register Summary									
0x00	STATUS	RSVD	RSVD	RSVD	RSVD	RSVD	RSVD	RSVD	/RDY
0x01	DATAh	Relative Humidity or Temperature, High Byte							
0x02	DATAl	Relative Humidity or Temperature, Low Byte							
0x03	CONFIG	RSVD	RSVD	FAST	TEMP	RSVD	RSVD	HEAT	START
0x11	ID	ID3	ID2	ID1	ID0	0	0	0	0
0x84 0xB8	FWREV	MAJREV				MINREV			
Notes:									
1. Any register address not listed here is reserved and must not be written.									
2. Reserved register bits (RSVD) must always be written as zero; the result of a read operation on these bits is undefined.									

6.1. Register Detail

Register 0. STATUS

Bit	D7	D6	D5	D4	D3	D2	D1	D0
Name								/RDY
Type	R							

Reset Settings = 0000_0001

Bit	Name	Function
7:1	Reserved	Reserved. Reads undefined.
0	/RDY	Ready. 0 = conversion complete; results available in DATAh:DATAI. 1 = conversion in progress.

Register 0x01. DATAh

Bit	D7	D6	D5	D4	D3	D2	D1	D0
Name	Relative Humidity or Temperature, High Byte							
Type	R							

Reset Settings = 0000_0000

Bit	Name	Function
7:0	DATAh	Data, High Byte. Eight most significant bits of a temperature or humidity measurement. See Table 11 or Table 13 for the measurement format.

Register 0x02. DATAI

Bit	D7	D6	D5	D4	D3	D2	D1	D0
Name	Relative Humidity or Temperature, Low Byte							
Type	Read							

Reset Settings = 0000_0000

Bit	Name	Function
7:0	DATAI	Data, Low Byte. Eight least significant bits of a temperature or humidity measurement. See Table 11 or Table 13 for the measurement format.

Si7015-A20

Register 0x03. CONFIG

Bit	D7	D6	D5	D4	D3	D2	D1	D0
Name			FAST	TEMP			HEAT	START
Type			R/W	R/W			R/W	R/W

Reset Settings = 0000_0000

Bit	Name	Function
7:6	Reserved	Reserved. Reads undefined. Always write as zero.
5	FAST	Fast Mode Enable. 0 = 5.8 ms (typical) 1 = 2.6 ms (typical)
4	TEMP	Temperature Enable. 0 = Relative humidity 1 = Temperature
3:2	Reserved	Reserved. Reads undefined. Always write as zero.
1	HEAT	Heater Enable. 0 = heater off 1 = heater on
0	START	Conversion Start. 0 = do not start a conversion 1 = start a conversion

Register 0x11. ID

Bit	D7	D6	D5	D4	D3	D2	D1	D0
Name	ID7	ID6	ID5	ID4	ID3	ID2	ID1	ID0
Type	R	R	R	R	R	R	R	R

Reset Settings = 0101_0000

Bit	Name	Function
7:0	ID	Identification. See Section "5.1.6. Device Identification" for reset settings.

Register 0x84 0xB8. FWREV

Bit	D7	D6	D5	D4	D3	D2	D1	D0
Name	MAJREV				MINREV			
Type	R				R			

Bit	Name	Function
7:4	MAJREV	Major firmware revision number
3:0	MINREV	Minor firmware revision number

Si7015-A20

7. Pin Descriptions: Si7015

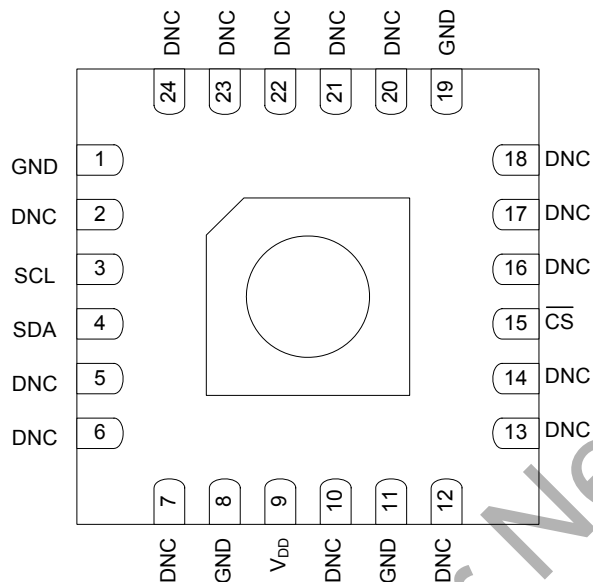

Table 21. Pin Descriptions

Pin #	Pin Name	Pin Type*	Description
1, 8, 11, 19	GND	G	Ground.
2, 5–7, 12–14, 16–18, 20–24	DNC		Do Not Connect. Do not connect any of these pins to supply, ground or any other signal. Internal pull-ups or pull-downs will prevent any of these pins from floating.
3	SCL	I	I²C Clock Signal. This pin is voltage-tolerant. See Table 2.
4	SDA	I/O	I²C Data Signal. This pin is voltage-tolerant. See Table 2.
9	V _{DD}	S	V_{DD} Power Supply (1.9 V ≤ V_{DD} ≤ 3.6 V).
10	DNC	I	If Si7015 is replacing an Si7005, the capacitor connected to Pin 10 may be left connected or removed.
15	$\overline{\text{CS}}$	I	Chip Select—Active Low Signal.
Epad	T _{GND}	G	Thermal Paddle. This pad is connected to GND internally. The pad can be connected to GND externally or it can be left open-circuit and used as a thermal input to the on-chip temperature sensor.

***Note:** G = Ground, S = Power Supply, I = Digital Input, O = Digital Output, I/O = Input/Output.

8. Ordering Guide

Table 22. Si7015 Device Ordering Guide

P/N	Description	Max Accuracy		Pkg	Operating Range (°C)	Protective Cover	Packing Format
		Temp	RH				
Si7015-A20-FM	Digital temperature/humidity sensor	±1 °C	±4.5%	QFN-24	0 to 70 °C	N	Cut Tape
Si7015-A20-FMR	Digital temperature/humidity sensor	±1 °C	±4.5%	QFN-24	0 to 70 °C	N	Tape-and-reel
Si7015-A20-FM1	Digital temperature/humidity sensor	±1 °C	±4.5%	QFN-24	0 to 70 °C	Y	Cut tape
Si7015-A20-FM1R	Digital temperature/humidity sensor	±1 °C	±4.5%	QFN-24	0 to 70 °C	Y	Tape-and-reel
Si7015-A20-GM	Digital temperature/humidity sensor	±1 °C	±4.5%	QFN-24	-40 to +85 °C	N	Cut Tape
Si7015-A20-GMR	Digital temperature/humidity sensor	±1 °C	±4.5%	QFN-24	-40 to +85 °C	N	Tape-and-reel
Si7015-A20-GM1	Digital temperature/humidity sensor	±1 °C	±4.5%	QFN-24	-40 to +85 °C	Y	Cut tape
Si7015-A20-GM1R	Digital temperature/humidity sensor	±1 °C	±4.5%	QFN-24	-40 to +85 °C	Y	Tape-and-reel

Note: The "A" denotes product revision A and "20" denotes firmware version 2.0.

9. Package Outline

9.1. 24-Pin QFN

Figure 8 illustrates the package details for the Si7015. Tables 23 and 24 list the values for the dimensions shown in the illustration. There are two package variants with slightly different height dimensions. The two package variants are otherwise interchangeable.

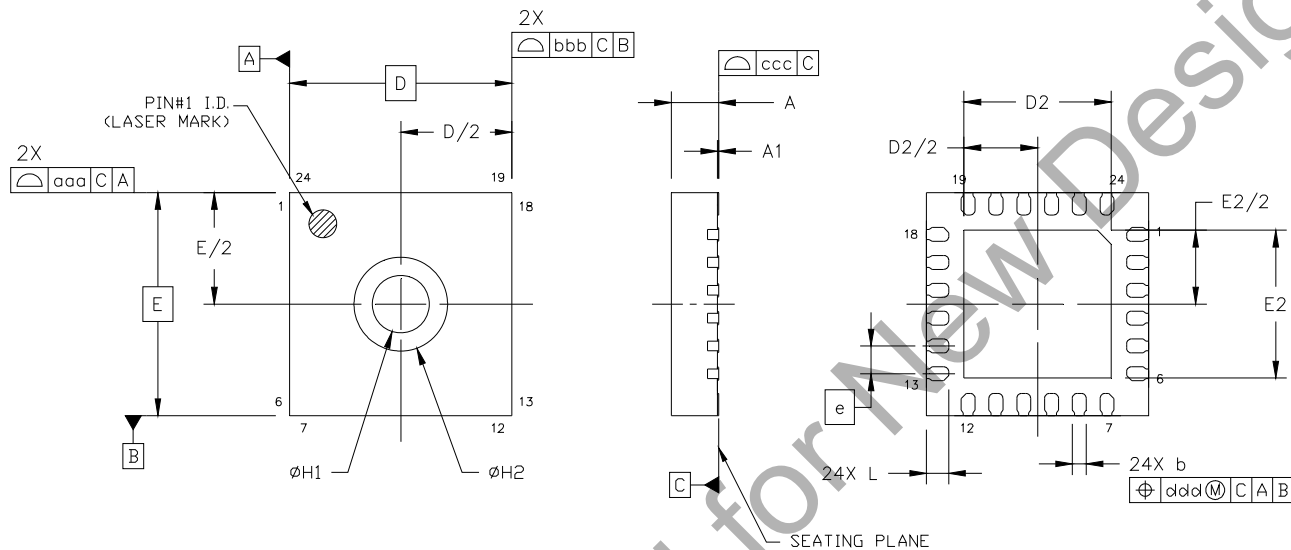

Figure 8. 24-Pin Quad Flat No Lead (QFN)

Table 23. 24-Pin Package Diagram Dimensions

Dimension	Min	Nom	Max	Dimension	Min	Nom	Max
A1	0.00	0.02	0.05	H1	1.03	1.08	1.13
b	0.18	0.25	0.30	H2	1.68 REF		
D	4.00 BSC.			L	0.30	0.35	0.40
D2	2.55	2.65	2.75	aaa	—	—	0.15
e	0.50 BSC.			bbb	—	—	0.15
E	4.00 BSC.			ccc	—	—	0.08
E2	2.55	2.65	2.75	ddd	—	—	0.10

Notes:

1. Dimensioning and Tolerancing per ANSI Y14.5M-1994.
2. Recommended card reflow profile is per the JEDEC/IPC J-STD-020 specification for Small Body Components.

Table 24. Package Variants

Dimension	Variant A			Variant B		
	Min	Nom	Max	Min	Nom	Max
A	0.80	0.90	1.00	0.70	0.75	0.80

Note: All Dimensions are in mm unless otherwise noted.

9.2. 24-Pin QFN with Protective Cover

Figure 9 illustrates the package details for the Si7015 with the optional protective cover. Tables 25 and 26 list the values for the dimensions shown in the illustration. There are two package variants with slightly different height dimensions. The two package variants are otherwise interchangeable.

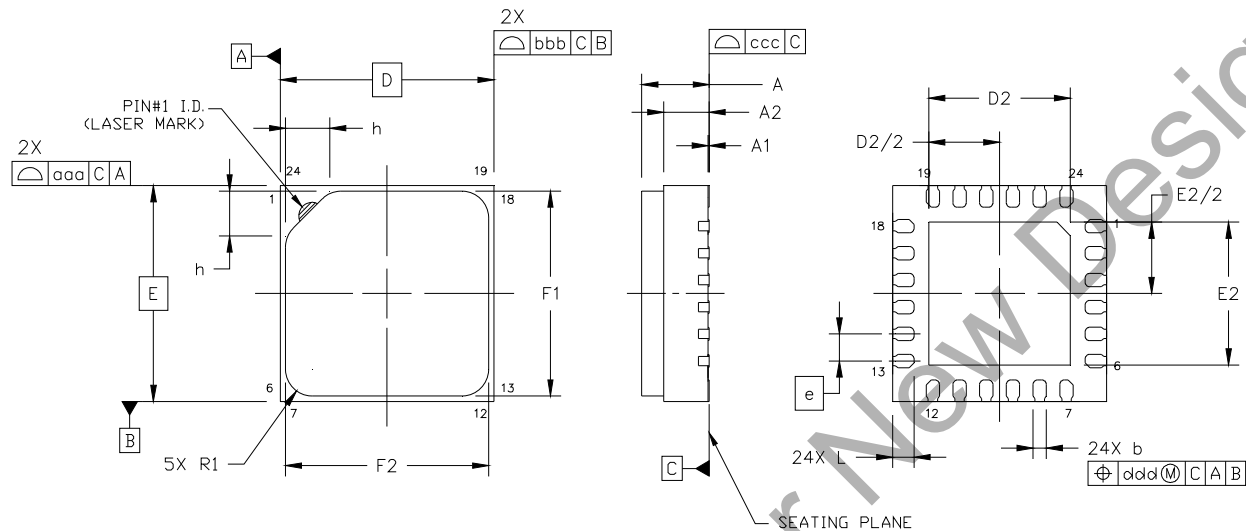

Figure 9. 24-Pin Quad Flat No Lead (QFN) With Protective Cover

Table 25. 24-Pin Package Diagram Dimensions

Dimension	Min	Nom	Max	Dimension	Min	Nom	Max
A1	0.00	0.02	0.05	h	0.76	0.83	0.90
b	0.18	0.25	0.30	L	0.30	0.35	0.40
D	4.00 BSC.			R1	0.45	0.50	0.55
D2	2.55	2.65	2.75	aaa	—	—	0.15
e	0.50 BSC.			bbb	—	—	0.15
E	4.00 BSC.			ccc	—	—	0.08
E2	2.55	2.65	2.75	ddd	—	—	0.10
F1	3.60	3.75	3.90				
F2	3.60	3.75	3.90				

Notes:

1. Dimensioning and Tolerancing per ANSI Y14.5M-1994.
2. Recommended card reflow profile is per the JEDEC/IPC J-STD-020 specification for Small Body Components.

Table 26. Package Variants

Dimension	Variant A			Variant B		
	Min	Nom	Max	Min	Nom	Max
A	—	1.27	1.41	—	1.07	1.21
A2	0.80	0.90	1.00	0.70	0.75	0.80

Note: All Dimensions are in mm unless otherwise noted.

10. PCB Land Pattern and Solder Mask Design

Figure 10 illustrates the recommended PCB land pattern for use with the Si7015's 4x4 mm QFN package.

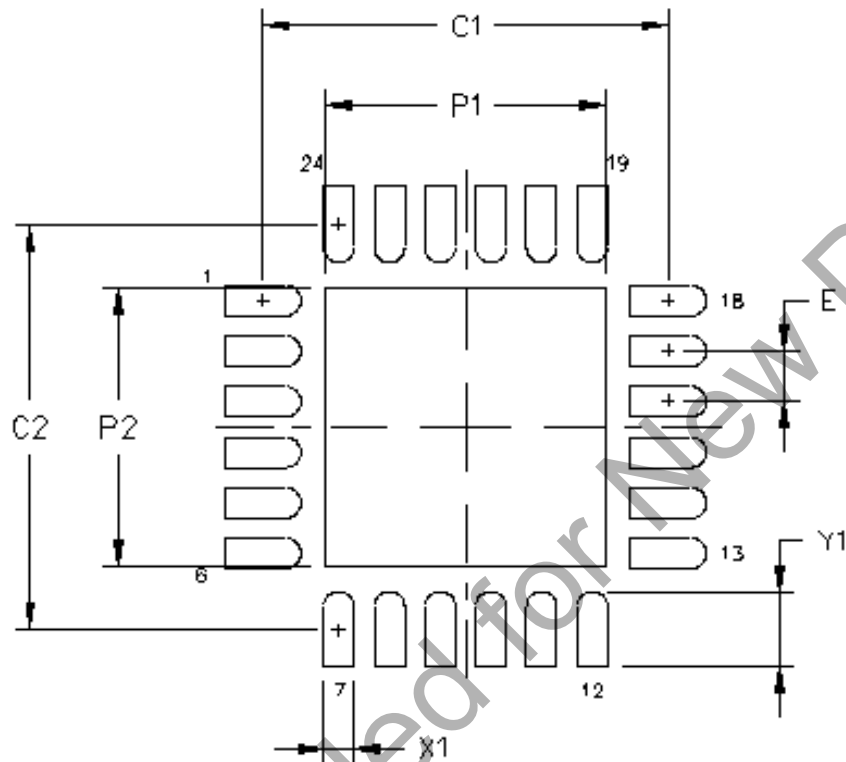

Figure 10. Typical QFN-24 PCB Land Pattern

Table 27. PCB Land Pattern Dimensions

Symbol	mm
C1	4.00
C2	4.00
E	0.50
P1	2.75
P2	2.75
X1	0.30
Y1	0.75

Notes:**General**

1. All dimensions shown are at Maximum Material Condition (MMC). Least Material Condition (LMC) is calculated based on a Fabrication Allowance of 0.05 mm.
2. This Land Pattern Design is based on the IPC-7351 guidelines.

Solder Mask Design

3. All metal pads are to be non-solder mask defined (NSMD). Clearance between the solder mask and the metal pad is to be 60 μm minimum, all the way around the pad.

Stencil Design

4. A stainless steel, laser-cut and electro-polished stencil with trapezoidal walls should be used to assure good solder paste release.
5. The stencil thickness should be 0.125 mm (5 mils).
6. The ratio of stencil aperture to land pad size should be 1:1 for all perimeter pins.
7. A 2x2 array of 0.95 mm square openings on 1.35 mm pitch should be used for the center ground pad.

Card Assembly

8. A No-Clean, Type-3 solder paste is recommended.
9. The recommended card reflow profile is per the JEDEC/IPC J-STD-020 specification for Small Body Components.

Si7015-A20

11. Top Marking

11.1. Si7015 Top Marking

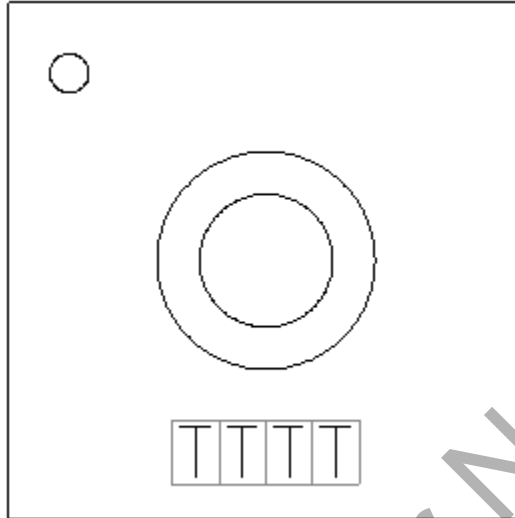

11.2. Top Marking Explanation

Mark Method:	Laser
Pin 1 Indicator:	Circle = 0.3 mm Diameter Upper-Left Corner
Font Size:	0.40 mm
Line 1 Marking:	TTTT = Manufacturing Code
Note: The top mark may not be visible if the optional protective cover is installed. If needed, the device can be identified by reading the identification register as explained in Section "5.1.6. Device Identification".	

12. Additional Reference Resources

- AN607: Si70xx Humidity Sensor Designer's Guide
- AN764: Upgrading from the Si7005 to the Si7015

Not Recommended for New Designs

DOCUMENT CHANGE LIST

Revision 0.9 to Revision 1.0

- Updated document revision to 1.0.

Revision 1.0 to Revision 1.1

- Minor modification to description and dimensions of protective cover due to the addition of a second cover supplier.

Revision 1.1 to Revision 1.2

- Changed packing format from tube to cut tape for all non-tape & reel part numbers without protective filter covers.

Not Recommended for New Designs

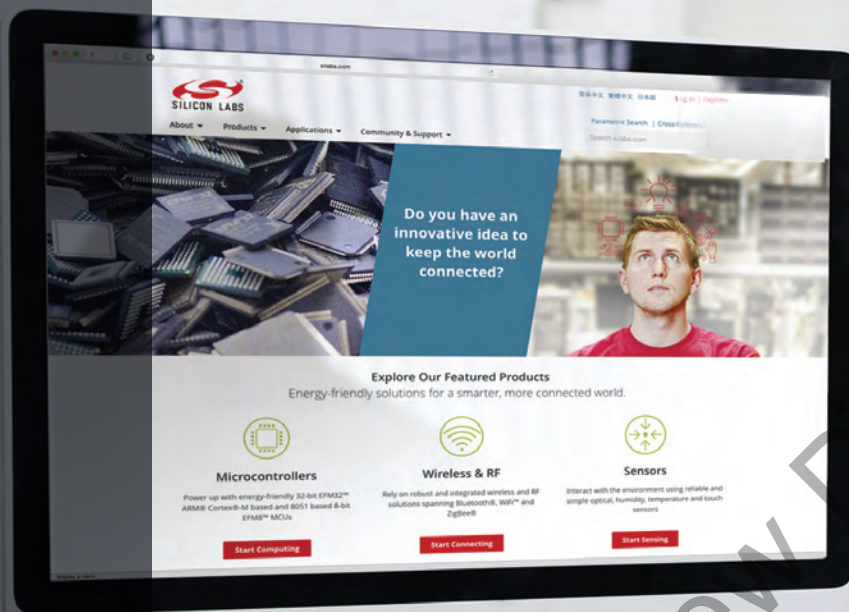

Smart.
Connected.
Energy-Friendly



Products
www.silabs.com/products

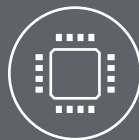

Quality
www.silabs.com/quality



Support and Community
community.silabs.com

Disclaimer

Silicon Laboratories intends to provide customers with the latest, accurate, and in-depth documentation of all peripherals and modules available for system and software implementers using or intending to use the Silicon Laboratories products. Characterization data, available modules and peripherals, memory sizes and memory addresses refer to each specific device, and "Typical" parameters provided can and do vary in different applications. Application examples described herein are for illustrative purposes only. Silicon Laboratories reserves the right to make changes without further notice and limitation to product information, specifications, and descriptions herein, and does not give warranties as to the accuracy or completeness of the included information. Silicon Laboratories shall have no liability for the consequences of use of the information supplied herein. This document does not imply or express copyright licenses granted hereunder to design or fabricate any integrated circuits. The products must not be used within any Life Support System without the specific written consent of Silicon Laboratories. A "Life Support System" is any product or system intended to support or sustain life and/or health, which, if it fails, can be reasonably expected to result in significant personal injury or death. Silicon Laboratories products are generally not intended for military applications. Silicon Laboratories products shall under no circumstances be used in weapons of mass destruction including (but not limited to) nuclear, biological or chemical weapons, or missiles capable of delivering such weapons.

Trademark Information

Silicon Laboratories Inc., Silicon Laboratories, Silicon Labs, SiLabs and the Silicon Labs logo, CMEMS®, EFM, EFM32, EFR, Energy Micro, Energy Micro logo and combinations thereof, "the world's most energy friendly microcontrollers", Ember®, EZLink®, EZMac®, EZRadio®, EZRadioPRO®, DSPLL®, ISOmodem®, Precision32®, ProSLIC®, SiPHY®, USBXpress® and others are trademarks or registered trademarks of Silicon Laboratories Inc. ARM, CORTEX, Cortex-M3 and THUMB are trademarks or registered trademarks of ARM Holdings. Keil is a registered trademark of ARM Limited. All other products or brand names mentioned herein are trademarks of their respective holders.



Silicon Laboratories Inc.
400 West Cesar Chavez
Austin, TX 78701
USA

<http://www.silabs.com>

Looking for pricing, stock, or lifecycle information?

Click below to explore more details on WIN SOURCE:

 [View SI7015-A20-GM on WIN SOURCE](#)

 [Silicon Labs](#) Information

Optimize Your Supply Chain with WIN SOURCE Solutions

-  Global Sourcing Solution
-  Obsolete Management
-  Cost Control Management
-  Shortage Management
-  Alternative Solution
-  Excess Inventory Management