



**THE DATASHEET OF
SI1141-A11-YM0**



PROXIMITY/AMBIENT LIGHT SENSOR IC WITH I²C INTERFACE

Features

- Integrated infrared proximity detector
 - Proximity detection adjustable from under 1 cm up to 200 cm
 - Three independent LED drivers
 - 15 current settings from 5.6 mA to 360 mA for each LED driver
 - 25.6 μ s LED driver pulse width
 - 50 cm proximity range with single pulse (<3 klx)
 - 15 cm proximity range with single pulse (>3 klx)
 - Operates at up to 128 klx (direct sunlight)
 - High reflectance sensitivity < 1 μ W/cm²
 - High EMI immunity without shielded packaging
- Integrated ambient light sensor
 - 100 mlx resolution possible, allowing operation under dark glass
 - 1 to 128 klx dynamic range possible across two ADC range settings
- Accurate lux measurements with IR correction algorithm
- Industry's lowest power consumption
 - 1.71 to 3.6 V supply voltage
 - 9 μ A average current (LED pulsed 25.6 μ s every 800 ms at 180 mA plus 3 μ A Si114x supply)
 - < 500 nA standby current
 - 25.6 μ s LED "on" time keeps total power consumption duty cycle low without compromising performance or noise immunity
 - Internal and external wake support
 - Built-in voltage supply monitor and power-on reset controller
- Serial communications
 - Up to 3.4 Mbps data rate
 - Slave mode hardware address decoding (0x5A)
- Small-outline 10-lead 2x2 mm QFN Temperature Range
 - -40 to +85 °C

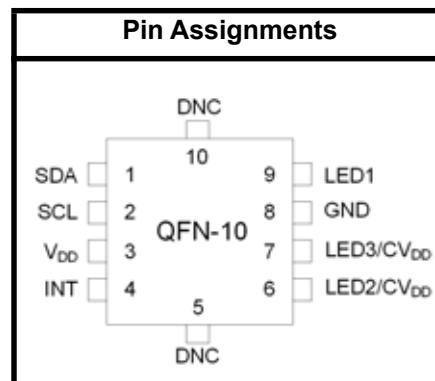

Applications

- Handsets
- Heart rate monitoring
- Pulse oximetry
- Wearables
- Audio products
- Security panels
- Tamper detection circuits
- Dispensers
- Valve controls
- Smoke detectors
- Touchless switches
- Touchless sliders
- Occupancy sensors
- Consumer electronics
- Industrial automation
- Display backlighting control
- Photo-interrupters

Description

The Si1141/42/43 is a low-power, reflectance-based, infrared proximity and ambient light sensor with I²C digital interface and programmable-event interrupt output. This touchless sensor IC includes an analog-to-digital converter, integrated high-sensitivity visible and infrared photodiodes, digital signal processor, and one, two, or three integrated infrared LED drivers with fifteen selectable drive levels. The Si1141/42/43 offers excellent performance under a wide dynamic range and a variety of light sources including direct sunlight. The Si1141/42/43 can also work under dark glass covers. The photodiode response and associated digital conversion circuitry provide excellent immunity to artificial light flicker noise and natural light flutter noise. With two or more LEDs, the Si1142/43 is capable of supporting multiple-axis proximity motion detection. The Si1141/42/43 devices are provided in a 10-lead 2x2 mm QFN package and are capable of operation from 1.71 to 3.6 V over the -40 to +85 °C temperature range.

Si1141/42/43

Functional Block Diagram

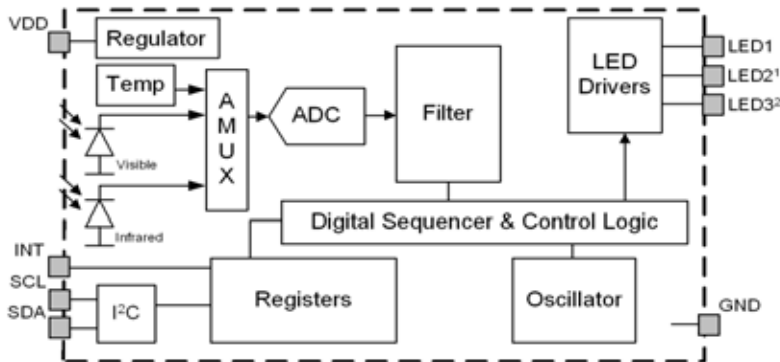

1. Si1142 and Si1143 only. Must be tied to V_{DD} with Si1141.
2. Si1143 only. Must be tied to V_{DD} with Si1141 and Si1142.

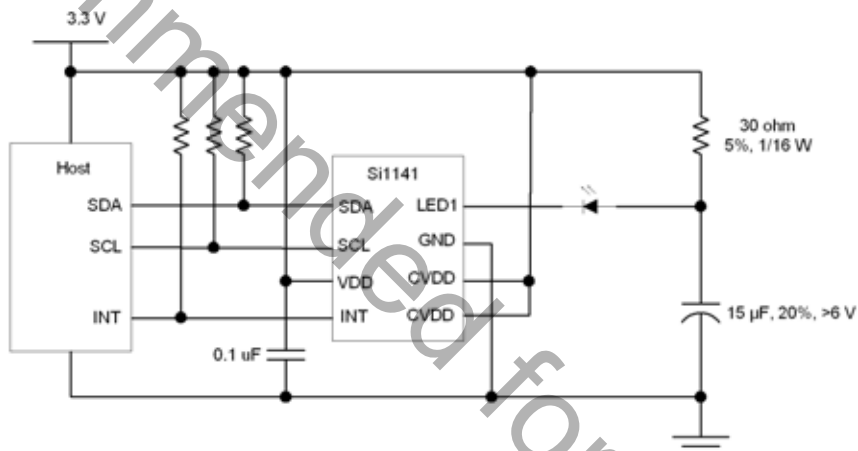

Figure 1. Si1141 Basic Application

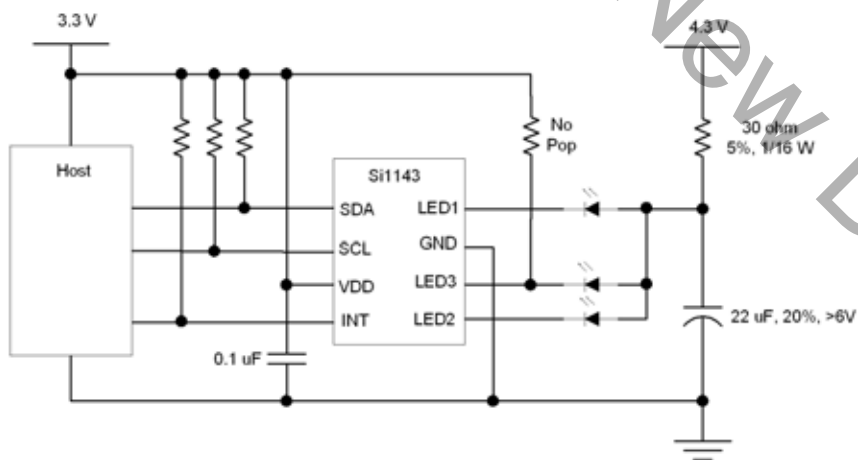

Figure 2. Si1143 Application with Three LEDs and Separate LED Power Supply

Note: For more application examples, refer to “AN498: Si114x Designer’s Guide”.

TABLE OF CONTENTS

1. Electrical Specifications	4
1.1. Performance Tables	4
1.2. Typical Performance Graphs	10
2. Functional Description	12
2.1. Introduction	12
2.2. Proximity Sensing (PS)	12
2.3. Ambient Light	13
2.4. Host Interface	14
3. Operational Modes	17
3.1. Off Mode	17
3.2. Initialization Mode	17
3.3. Standby Mode	17
3.4. Forced Conversion Mode	17
3.5. Autonomous Operation Mode	18
3.6. ALWAYS_ACTIVE Mode	18
3.7. Avoiding an Unexpected Reset	18
4. Programming Guide	20
4.1. Command and Response Structure	20
4.2. Command Protocol	21
4.3. Command Write Timing Limitations	23
4.4. Resource Summary	24
4.5. Signal Path Software Model	29
4.6. I2C Registers	30
4.7. Parameter RAM	54
5. Pin Descriptions	69
6. Ordering Guide	70
7. Package Outline: 10-Pin QFN	71
8. Suggested PCB Land Pattern	73
Document Change List	77

1. Electrical Specifications

1.1. Performance Tables

Table 1. Recommended Operating Conditions

Parameter	Symbol	Test Condition	Min	Typ	Max	Unit
V _{DD} Supply Voltage	V _{DD}		1.71	—	3.6	V
V _{DD} OFF Supply Voltage	V _{DD_OFF}	OFF mode	-0.3		1.0	V
V _{DD} Supply Ripple Voltage		V _{DD} = 3.3 V 1 kHz–10 MHz	—	—	50	mVpp
Operating Temperature	T		-40	25	85	°C
SCL, SDA, Input High Logic Voltage	I ² C _{VIH}		V _{DD} ×0.7	—	V _{DD}	V
SCL, SDA Input Low Logic Voltage	I ² C _{VIL}		0	—	V _{DD} ×0.3	V
PS Operation under Direct Sunlight	E _{dc}		—	—	128	klx
IrLED Emission Wavelength	λ		750	850	950	nm
IrLED Supply Voltage	V _{LED}	IrLED V _F = 1.0 V nominal	V _{DD}	—	4.3	V
IrLED Supply Ripple Voltage		Applies if IrLEDs use separate supply rail 0–30 kHz 30 kHz–100 MHz	— —	— —	250 100	mVpp mVpp
Start-Up Time		V _{DD} above 1.71 V	25	—	—	ms
LED3 Voltage		Start-up	V _{DD} ×0.77	—	—	V

Table 2. Performance Characteristics¹

Parameter	Symbol	Test Condition	Min	Typ	Max	Unit
I _{DD} OFF Mode	I _{off}	V _{DD} < V _{DD_OFF} (leakage from SCL, SDA, and INT not included)	—	240	1000	nA
I _{DD} Standby Mode	I _{sb}	No ALS / PS Conversions No I ² C Activity V _{DD} = 1.8 V	—	150	500	nA

Notes:

1. Unless specifically stated in "Conditions", electrical data assumes ambient light levels < 1 klx.
2. Proximity-detection performance may be degraded, especially when there is high optical crosstalk, if the LED supply and voltage drop allow the driver to saturate and current regulation is lost.
3. Guaranteed by design and characterization.
4. Represents the time during which the device is drawing a current equal to I_{active} for power estimation purposes. Assumes default settings.

Table 2. Performance Characteristics¹ (Continued)

Parameter	Symbol	Test Condition	Min	Typ	Max	Unit
I _{DD} Standby Mode	I _{sb}	No ALS / PS Conversions No I ² C Activity V _{DD} = 3.3 V	—	1.4	—	μA
I _{DD} Actively Measuring	I _{active}	Without LED influence, V _{DD} = 3.3 V	—	4.3	5.5	mA
Peak I _{DD} while LED1, LED2, or LED3 is Actively Driven		V _{DD} = 3.3 V	—	8	—	mA
LED Driver Saturation Voltage ^{2,3}		V _{DD} = 1.71 to 3.6 V PS_LEDn = 0001 PS_LEDn = 0010 PS_LEDn = 0011 PS_LEDn = 0100 PS_LEDn = 0101 PS_LEDn = 0110 PS_LEDn = 0111 PS_LEDn = 1000 PS_LEDn = 1010 PS_LEDn = 1010 PS_LEDn = 1011 PS_LEDn = 1100 PS_LEDn = 1101 PS_LEDn = 1110 PS_LEDn = 1111	—	50 60 70 80 115 150 185 220 255 290 315 340 360 385 410	70 105 105 105 450 450 450 450 450 600 600 600 600	mV
LED1, LED2, LED3 Pulse Width	t _{PS}		—	25.6	30	μs
LED1, LED2, LED3, INT, SCL, SDA Leakage Current		V _{DD} = 3.3 V	-1	—	1	μA
Notes:						
<ol style="list-style-type: none"> 1. Unless specifically stated in "Conditions", electrical data assumes ambient light levels < 1 klx. 2. Proximity-detection performance may be degraded, especially when there is high optical crosstalk, if the LED supply and voltage drop allow the driver to saturate and current regulation is lost. 3. Guaranteed by design and characterization. 4. Represents the time during which the device is drawing a current equal to I_{active} for power estimation purposes. Assumes default settings. 						

Table 2. Performance Characteristics¹ (Continued)

Parameter	Symbol	Test Condition	Min	Typ	Max	Unit
LED1, LED2, LED3 Active Current	I_{LEDx}	$V_{DD} = 3.3$ V, single drive				mA
		$V_{LEDn} = 1$ V, PS_LEDn = 0001	3.5	5.6	7	
		$V_{LEDn} = 1$ V, PS_LEDn = 0010	—	11.2	—	
		$V_{LEDn} = 1$ V, PS_LEDn = 0011	13	22.4	29	
		$V_{LEDn} = 1$ V, PS_LEDn = 0100	—	45	—	
		$V_{LEDn} = 1$ V, PS_LEDn = 0101	—	67	—	
		$V_{LEDn} = 1$ V, PS_LEDn = 0110	—	90	—	
		$V_{LEDn} = 1$ V, PS_LEDn = 0111	—	112	—	
		$V_{LEDn} = 1$ V, PS_LEDn = 1000	—	135	—	
		$V_{LEDn} = 1$ V, PS_LEDn = 1001	—	157	—	
		$V_{LEDn} = 1$ V, PS_LEDn = 1010	—	180	—	
		$V_{LEDn} = 1$ V, PS_LEDn = 1011	—	202	—	
		$V_{LEDn} = 1$ V, PS_LEDn = 1100	—	224	—	
		$V_{LEDn} = 1$ V, PS_LEDn = 1101	—	269	—	
$V_{LEDn} = 1$ V, PS_LEDn = 1110	—	314	—			
$V_{LEDn} = 1$ V, PS_LEDn = 1111	—	359	—			
Actively Measuring Time ⁴		Single PS	—	155	—	μ s
		ALS VIS + ALS IR	—	285	—	μ s
		Two ALS plus three PS	—	660	—	μ s
Visible Photodiode Response		Sunlight ALS_VIS_ADC_GAIN = 0 VIS_RANGE = 0	—	0.282	—	ADC counts/lux
		2500K incandescent bulb ALS_VIS_ADC_GAIN = 0 VIS_RANGE = 0	—	0.319	—	ADC counts/lux
		“Cool white” fluorescent ALS_VIS_ADC_GAIN = 0 VIS_RANGE = 0	—	0.146	—	ADC counts/lux
		Infrared LED (875 nm) ALS_VIS_ADC_GAIN = 0 VIS_RANGE = 0	—	8,277	—	ADC counts.m ² / W

Notes:

1. Unless specifically stated in "Conditions", electrical data assumes ambient light levels < 1 klx.
2. Proximity-detection performance may be degraded, especially when there is high optical crosstalk, if the LED supply and voltage drop allow the driver to saturate and current regulation is lost.
3. Guaranteed by design and characterization.
4. Represents the time during which the device is drawing a current equal to I_{active} for power estimation purposes. Assumes default settings.

Table 2. Performance Characteristics¹ (Continued)

Parameter	Symbol	Test Condition	Min	Typ	Max	Unit
Small Infrared Photodiode Response		Sunlight ALS_IR_ADC_GAIN = 0 IR_RANGE = 0	—	2.44	—	ADC counts/lux
		2500K incandescent bulb ALS_IR_ADC_GAIN = 0 IR_RANGE = 0	—	8.46	—	ADC counts/lux
		“Cool white” fluorescent ALS_IR_ADC_GAIN = 0 IR_RANGE = 0	—	0.71	—	ADC counts/lux
		Infrared LED (875 nm) ALS_IR_ADC_GAIN = 0 IR_RANGE = 0	—	452.38	—	ADC counts.m ² /W
Large Infrared Photodiode Response		Sunlight PS_ADC_GAIN = 0 PS_RANGE = 0 PS_ADC_MODE = 0	—	14.07	—	ADC counts/lux
		2500K incandescent bulb PS_ADC_GAIN = 0 PS_RANGE = 0 PS_ADC_MODE = 0	—	50.47	—	ADC counts/lux
		“Cool white” fluorescent PS_ADC_GAIN = 0 PS_RANGE = 0 PS_ADC_MODE = 0	—	3.97	—	ADC counts/lux
		Infrared LED (875 nm) PS_ADC_GAIN = 0 PS_RANGE = 0 PS_ADC_MODE = 0	—	2734	—	ADC counts.m ² /W
Visible Photodiode Noise		All gain settings	—	7	—	ADC counts RMS
Small Infrared Photodiode Noise		All gain settings	—	1	—	ADC counts RMS

Notes:

1. Unless specifically stated in "Conditions", electrical data assumes ambient light levels < 1 klx.
2. Proximity-detection performance may be degraded, especially when there is high optical crosstalk, if the LED supply and voltage drop allow the driver to saturate and current regulation is lost.
3. Guaranteed by design and characterization.
4. Represents the time during which the device is drawing a current equal to I_{active} for power estimation purposes. Assumes default settings.

Table 2. Performance Characteristics¹ (Continued)

Parameter	Symbol	Test Condition	Min	Typ	Max	Unit
Large Infrared Photodiode Noise		All gain settings	—	10	—	ADC counts RMS
Visible Photodiode Offset Drift		VIS_RANGE = 0 ALS_VIS_ADC_GAIN = 0 ALS_VIS_ADC_GAIN = 1 ALS_VIS_ADC_GAIN = 2 ALS_VIS_ADC_GAIN = 3 ALS_VIS_ADC_GAIN = 4 ALS_VIS_ADC_GAIN = 5 ALS_VIS_ADC_GAIN = 6 ALS_VIS_ADC_GAIN = 7	—	-0.3 -0.11 -0.06 -0.03 -0.01 -0.008 -0.007 -0.008	—	ADC counts/°C
Small Infrared Photodiode Offset Drift		IR_RANGE = 0 IR_GAIN = 0 IR_GAIN = 1 IR_GAIN = 2 IR_GAIN = 3	—	-0.3 -0.06 -0.03 -0.01	—	ADC counts/°C
SCL, SDA, INT Output Low Voltage	V _{OL}	I = 4 mA, V _{DD} > 2.0 V I = 4 mA, V _{DD} < 2.0 V	— —	— —	V _{DD} × 0.2 0.4	V V
Temperature Sensor Offset		25 °C	—	11136	—	ADC counts
Temperature Sensor Gain			—	35	—	ADC counts/°C

Notes:

1. Unless specifically stated in "Conditions", electrical data assumes ambient light levels < 1 klx.
2. Proximity-detection performance may be degraded, especially when there is high optical crosstalk, if the LED supply and voltage drop allow the driver to saturate and current regulation is lost.
3. Guaranteed by design and characterization.
4. Represents the time during which the device is drawing a current equal to I_{active} for power estimation purposes. Assumes default settings.

Table 3. I²C Timing Specifications

Parameter	Symbol	Min	Typ	Max	Unit
Clock Frequency	f _{SCL}	0.09	—	3.4	MHz
Clock Pulse Width Low	t _{LOW}	160	—	—	ns
Clock Pulse Width High	t _{HIGH}	60	—	—	ns
Rise Time	t _R	10	—	40	ns
Fall Time	t _F	10	—	40	ns
Start Condition Hold Time	t _{HD.STA}	160	—	—	ns
Start Condition Setup Time	t _{SU.STA}	160	—	—	ns
Input Data Setup Time	t _{SU.DAT}	10	—	—	ns
Input Data Hold Time	t _{HD.DAT}	0	—	—	ns
Stop Condition Setup Time	t _{SU.STO}	160	—	—	ns

Table 4. Absolute Maximum Limits

Parameter	Test Condition	Min	Typ	Max	Unit
V _{DD} Supply Voltage		-0.3	—	4	V
Operating Temperature		-40	—	85	°C
Storage Temperature		-65	—	85	°C
LED1, LED2, LED3 Voltage	at V _{DD} = 0 V, T _A < 85 °C	-0.5	—	3.6	V
INT, SCL, SDA Voltage	at V _{DD} = 0 V, T _A < 85 °C	-0.5	—	3.6	V
Maximum total current through LED1, LED2 and LED3		—	—	500	mA
Maximum total current through GND		—	—	600	mA
ESD Rating	Human Body Model	—	—	2	kV
	Machine Model	—	—	225	V
	Charged-Device Model	—	—	2	kV

1.2. Typical Performance Graphs

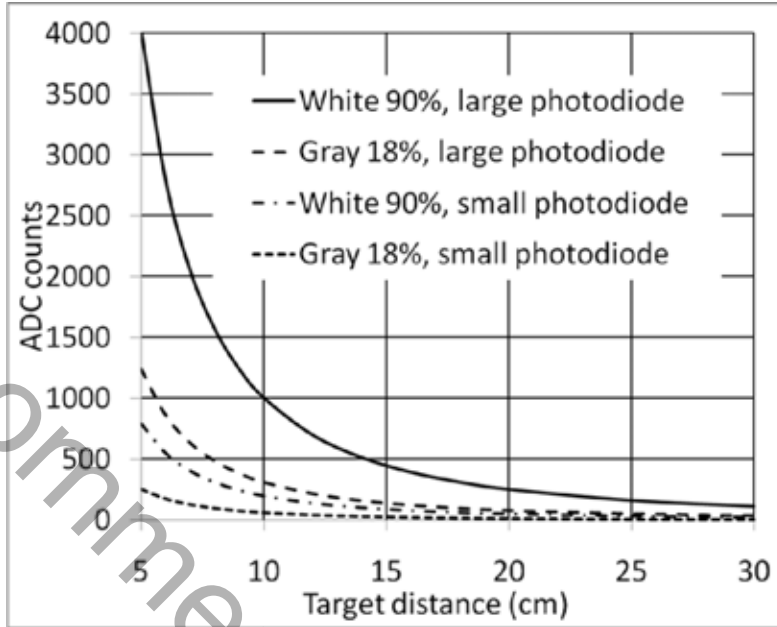

Figure 3. Proximity response using Kodak gray cards, PS_RANGE = 0, PS_ADC_GAIN = 0 (single 25.6µs LED pulse), ± 22° LED view angle, 850 nm, 22.5 mW/sr, no overlay, 5 mm LED center to Si114x center

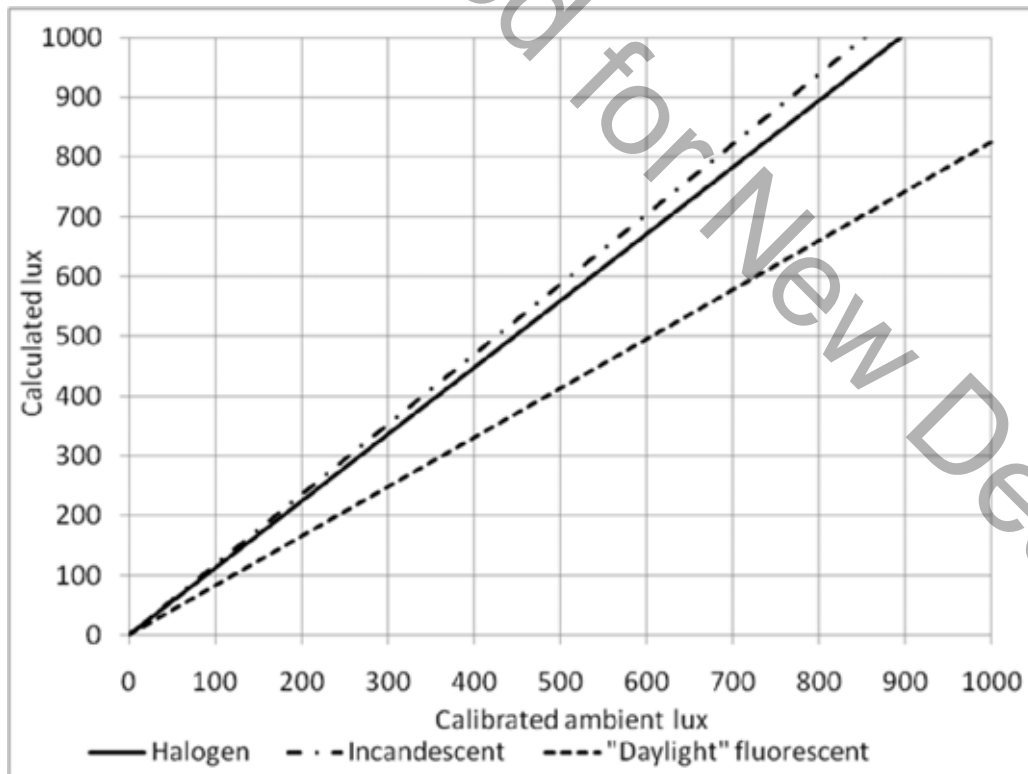

Figure 4. ALS variability with different light sources

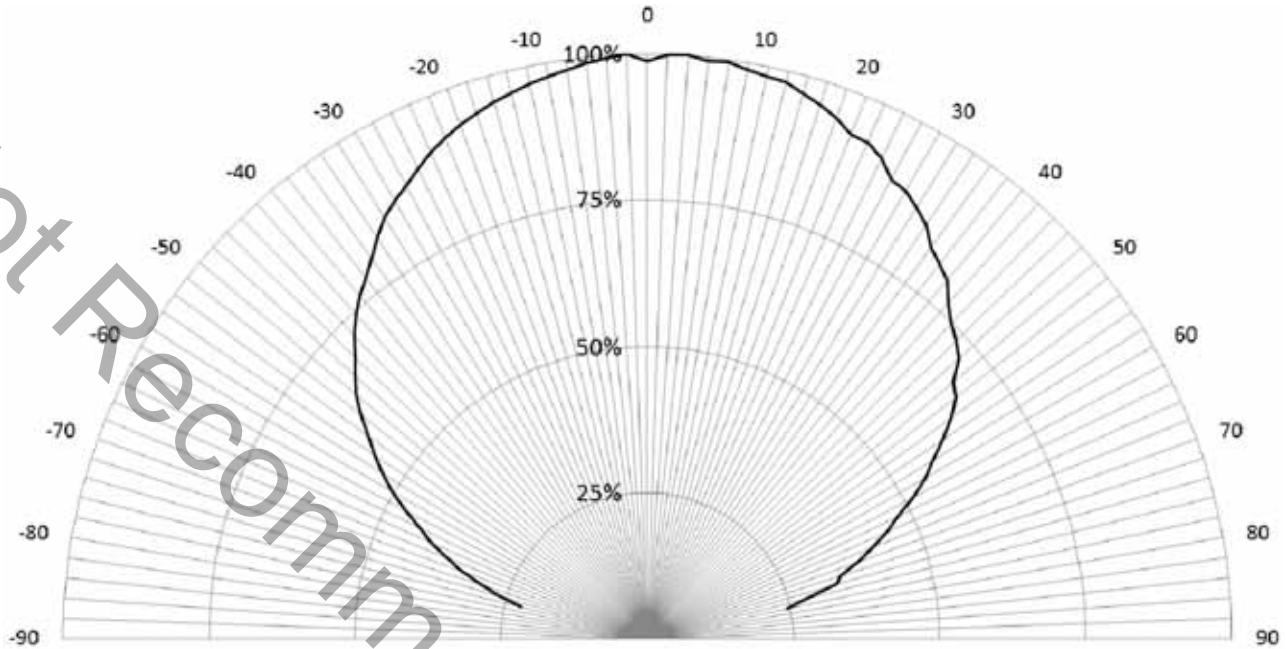

Figure 5. View angle, large photodiode rotated around the pin-5/pin-10 (“vertical”) axis

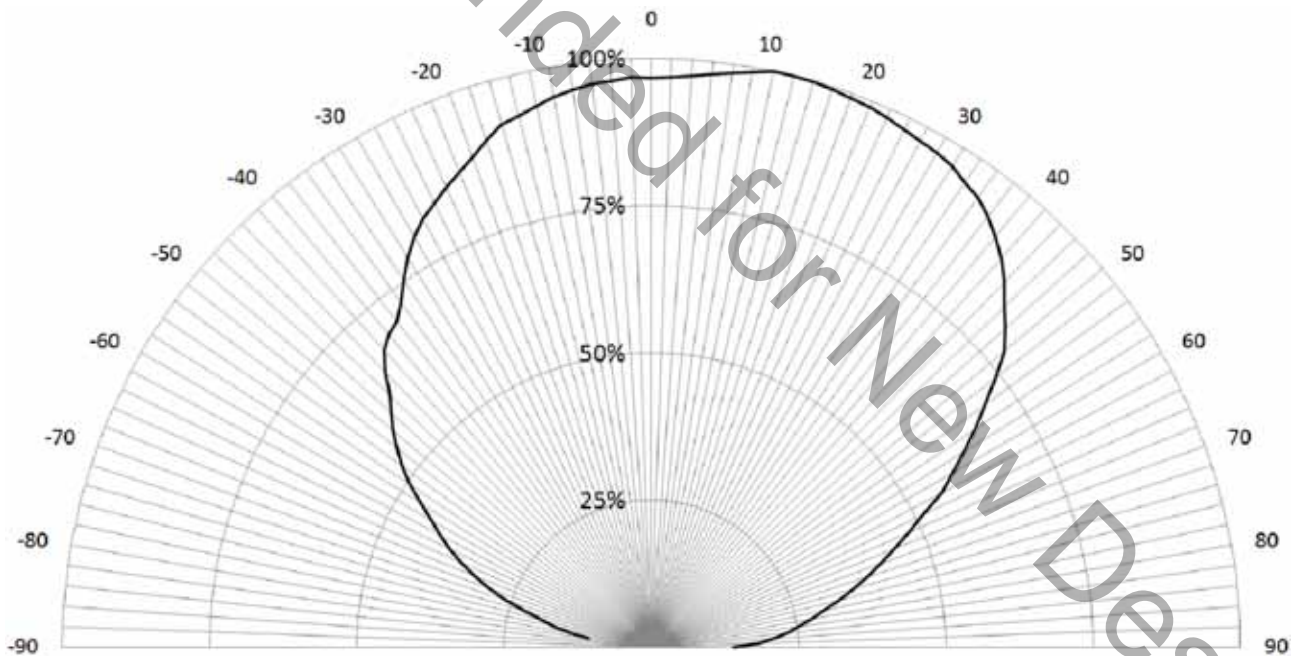

Figure 6. View angle, large photodiode rotated around “horizontal” axis and small photodiode rotated around either axis

2. Functional Description

2.1. Introduction

The Si1141/42/43 is an active optical reflectance proximity detector and ambient light sensor whose operational state is controlled through registers accessible through the I²C interface. The host can command the Si1141/42/43 to initiate on-demand proximity detection or ambient light sensing. The host can also place the Si1141/42/43 in an autonomous operational state where it performs measurements at set intervals and interrupts the host either after each measurement is completed or whenever a set threshold has been crossed. This results in an overall system power saving allowing the host controller to operate longer in its sleep state instead of polling the Si1141/42/43. For more details, refer to "AN498: Si114x Designer's Guide".

2.2. Proximity Sensing (PS)

The Si1141/42/43 has been optimized for use as either a dual-port or single-port active reflection proximity detector. Over distances of less than 50 cm, the dual-port active reflection proximity detector has significant advantages over single-port, motion-based infrared systems, which are only good for triggered events. Motion-based infrared detectors identify objects within proximity, but only if they are moving. Single-port motion-based infrared systems are ambiguous about stationary objects even if they are within the proximity field. The Si1141/42/43 can reliably detect an object entering or exiting a specified proximity field, even if the object is not moving or is moving very slowly. However, beyond about 30–50 cm, even with good optical isolation, single-port signal processing may be required due to static reflections from nearby objects, such as table tops, walls, etc. If motion detection is acceptable, the Si1141/42/43 can achieve ranges of up to 50 cm, through a single product window.

For small objects, the drop in reflectance is as much as the fourth power of the distance. This means that there is less range ambiguity than with passive motion-based devices. For example, a sixteenfold change in an object's reflectance means only a fifty-percent drop in detection range.

The Si1143 can drive three separate infrared LEDs. When the three infrared LEDs are placed in an L-shaped configuration, it is possible to triangulate an object within the three-dimensional proximity field. Thus, a touchless user interface can be implemented with the aid of host software.

The Si1141/42/43 can initiate proximity sense measurements when explicitly commanded by the host or periodically through an autonomous process. Refer to "3. Operational Modes" on page 17 for additional details of the Si1141/42/43's Operational Modes.

Whenever it is time to make a PS measurement, the Si1141/42/43 makes up to three measurements, depending on what is enabled in the CHLIST parameter. Other ADC parameters for these measurements can also be modified to allow proper operation under different ambient light conditions.

The LED choice is programmable for each of these three measurements. By default, each measurement turns on a single LED driver. However, the order of measurements can be easily reversed or even have all LEDs turned on at the same time. Optionally, each proximity measurement can be compared against a host-programmable threshold. With threshold settings for each PS channel, it is also possible for the Si1141/42/43 to notify the host whenever the threshold has been crossed. This reduces the number of interrupts to the host, aiding in efficient software algorithms.

The Si1141/42/43 can also generate an interrupt after a complete set of proximity measurements, ignoring any threshold settings.

To support different power usage cases dynamically, the infrared LED current of each output is independently programmable. The current can be programmed anywhere from a few to several hundred milliamps. Therefore, the host can optimize for proximity detection performance or for power saving dynamically. This feature can be useful since it allows the host to reduce the LED current once an object has entered a proximity sphere, and the object can still be tracked at a lower current setting. Finally, the flexible current settings make it possible to control the infrared LED currents with a controlled current sink, resulting in higher precision.

The ADC properties are programmable. For indoor operation, the ADC should be configured for low signal range for best reflectance sensitivity. When under high ambient conditions, the ADC should be configured for high signal level range operation.

When operating in the lower signal range, it is possible to saturate the ADC when the ambient light level is high. Any overflow condition is reported in the RESPONSE register, and the corresponding data registers report a value of 0xFFFF. The host can then adjust the ADC sensitivity. Note however that the overflow condition is not sticky. If the light levels return to a range within the capabilities of the ADC, the corresponding data registers begin to operate normally. However, the RESPONSE register will continue to hold the overflow condition until a NOP command is received. Even if the RESPONSE register has an overflow condition, commands are still accepted and processed.

Proximity detection ranges beyond 50 cm and up to several meters can be achieved without lensing by selecting a longer integration time. The detection range may be increased further, even with high ambient light, by averaging multiple measurements. Refer to “AN498: Si114x Designer's Guide” for more details.

2.3. Ambient Light

The Si1141/42/43 has photodiodes capable of measuring both visible and infrared light. However, the visible photodiode is also influenced by infrared light. The measurement of illuminance requires the same spectral response as the human eye. If an accurate lux measurement is desired, the extra IR response of the visible-light photodiode must be compensated. Therefore, to allow the host to make corrections to the infrared light's influence, the Si1141/42/43 reports the infrared light measurement on a separate channel. The separate visible and IR photodiodes lend themselves to a variety of algorithmic solutions. The host can then take these two measurements and run an algorithm to derive an equivalent lux level as perceived by a human eye. Having the IR correction algorithm running in the host allows for the most flexibility in adjusting for system-dependent variables. For example, if the glass used in the system blocks visible light more than infrared light, the IR correction needs to be adjusted.

If the host is not making any infrared corrections, the infrared measurement can be turned off in the CHLIST parameter.

By default, the measurement parameters are optimized for indoor ambient light levels where it is possible to detect light levels as low as 6 lx. For operation under direct sunlight, the ADC can be programmed to operate in a high signal operation so that it is possible to measure direct sunlight without overflowing the 16-bit result.

For low-light applications, it is possible to increase the ADC integration time. Normally, the integration time is 25.6 μ s. By increasing this integration time to 410 μ s, the ADC can detect light levels as low as 1 lx. The ADC can be programmed with an integration time as high as 3.28 ms, allowing measurement to 100 mlx light levels. The ADC integration time for the Visible Light Ambient measurement can be programmed independently of the ADC integration time of the Infrared Light Ambient measurement. The independent ADC parameters allow operation under glass covers having a higher transmittance to Infrared Light than Visible Light.

When operating in the lower signal range, or when the integration time is increased, it is possible to saturate the ADC when the ambient light suddenly increases. Any overflow condition is reported in the RESPONSE register, and the corresponding data registers report a value of 0xFFFF. Based on either of these two overflow indicators, the host can adjust the ADC sensitivity. However, the overflow condition is not sticky. If the light levels return to a range within the capabilities of the ADC, the corresponding data registers begin to operate normally. The RESPONSE register will continue to hold the overflow condition until a NOP command is received. Even if the RESPONSE register has an overflow condition, commands are still accepted and processed.

The Si1141/42/43 can initiate ALS measurements either when explicitly commanded by the host or periodically through an autonomous process. Refer to "3. Operational Modes" on page 17 for additional details of the Si1141/42/43's Operational Modes. The conversion frequency setting is programmable and independent of the Proximity Sensor. This allows the Proximity Sensor and Ambient Light sensor to operate at different conversion rates, increasing host control over the Si1141/42/43.

When operating autonomously, the ALS has a slightly different interrupt structure compared to the Proximity Sensor. An interrupt can be generated to the host on every sample, or when the ambient light has changed.

The “Ambient Light Changed” interrupt is accomplished through two thresholds working together to implement a window. As long as the ambient light stays within the window defined by the two thresholds, the host is not interrupted. When the ambient light changes and either threshold is crossed, an interrupt is sent to the host, thereby allowing the host notification that the ambient light has changed. This can be used by the host to trigger a recalculation of the lux values.

Si1141/42/43

The window can be applied to either the Visible Ambient Measurement, or the Infrared Ambient Measurement, but not both. However, monitoring the ambient change in either channel should allow notification that the ambient light level has changed.

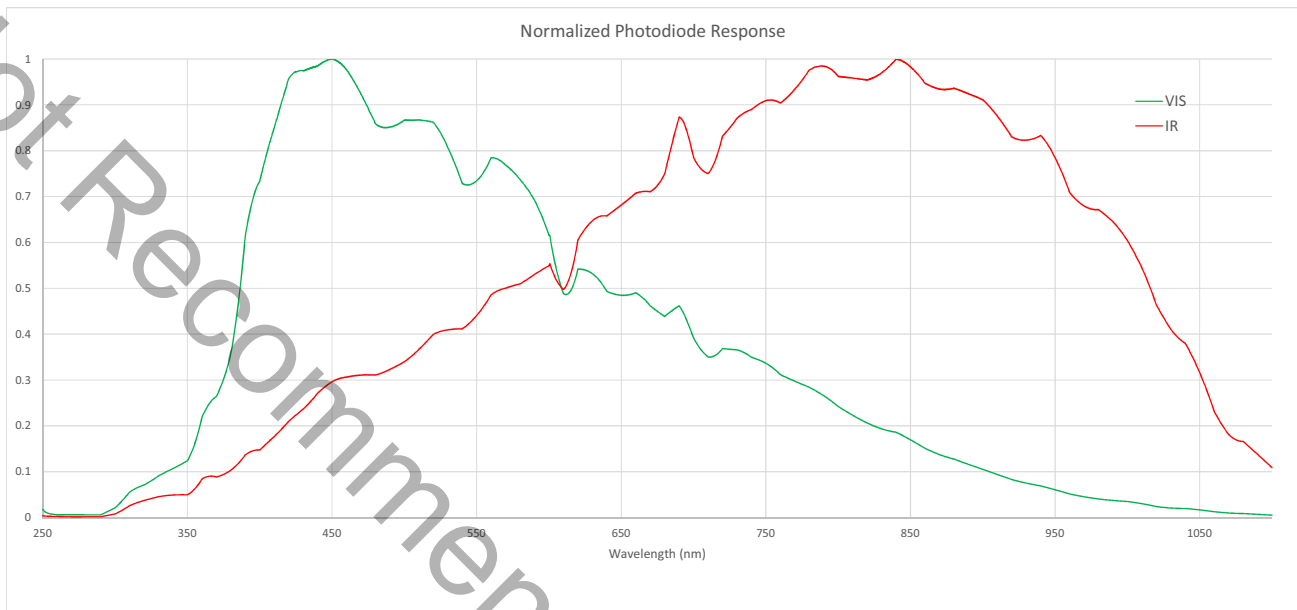

Figure 7. Photodiode Spectral Response to Visible and Infrared Light (Indicative)

2.4. Host Interface

The host interface to the Si1141/42/43 consists of three pins:

- SCL
- SDA
- INT

SCL and SDA are standard open-drain pins as required for I²C operation.

The Si1141/42/43 asserts the INT pin to interrupt the host processor. Right after internal power on reset, the INT pin is an input and should be driven to a high level. After that, the INT pin becomes an open-drain output.

A pull-up resistor to VDD is recommended for proper operation. The I²C/INT pins may be connected to VIO in systems. E.g., when Si114x is in OFF-mode, an I²C bus for other devices might need to be active. In this case, INT pins (via VIO through pull-up register) must be higher than 0.7xVDD within 20 μ s of VDD going above 1.6 V. During OFF-mode, total current on I²C/INT pins should be lower than 100 mA (600-500 mA). Refer to Table 4, "Absolute Maximum Limits," on page 9.

As an open-drain output, the INT pin can be shared with other open-drain interrupt sources in the system. If there is a possibility that other open-drain sources drive low around power on reset period, contact to Silicon Labs for details.

For proper operation, the Si1141/42/43 is expected to fully complete its Initialization Mode prior to any activity on the I²C.

The INT, SCL, and SDA pins are designed so that it is possible for the Si1141/42/43 to enter the Off Mode by software command without interfering with normal operation of other I²C devices on the bus.

The Si1141/42/43 I²C slave address is 0x5A. The Si1141/42/43 also responds to the global address (0x00) and the global reset command (0x06). Only 7-bit I²C addressing is supported; 10-bit I²C addressing is not supported.

Conceptually, the I²C interface allows access to the Si1141/42/43 internal registers. Table 15 on page 30 is a summary of these registers.

An I²C write access always begins with a start (or restart) condition. The first byte after the start condition is the I²C address and a read-write bit. The second byte specifies the starting address of the Si1141/42/43 internal register. Subsequent bytes are written to the Si1141/42/43 internal register sequentially until a stop condition is encountered. An I²C write access with only two bytes is typically used to set up the Si1141/42/43 internal address in preparation for an I²C read.

The I²C read access, like the I²C write access, begins with a start or restart condition. In an I²C read, the I²C master then continues to clock SCK to allow the Si1141/42/43 to drive the I²C with the internal register contents.

The Si1141/42/43 also supports burst reads and burst writes. The burst read is useful in collecting contiguous, sequential registers. The Si1141/42/43 register map was designed to optimize for burst reads for interrupt handlers, and the burst writes are designed to facilitate rapid programming of commonly used fields, such as thresholds registers.

The internal register address is a six-bit (bit 5 to bit 0) plus an Autoincrement Disable (on bit 6). The Autoincrement Disable is turned off by default. Disabling the autoincrementing feature allows the host to poll any single internal register repeatedly without having to keep updating the Si1141/42/43 internal address every time the register is read.

It is recommended that the host should read PS or ALS measurements (in the I²C Register Map) when the Si1141/42/43 asserts INT. Although the host can read any of the Si1141/42/43's I²C registers at any time, care must be taken when reading 2-byte measurements outside the context of an interrupt handler. The host could be reading part of the 2-byte measurement when the internal sequencer is updating that same measurement coincidentally. When this happens, the host could be reading a hybrid 2-byte quantity whose high byte and low byte are parts of different samples. If the host must read these 2-byte registers outside the context of an interrupt handler, the host should “double-check” a measurement if the measurement deviates significantly from a previous reading.

I²C Broadcast Reset: The I²C Broadcast Reset should be sent prior to any I²C register access to the Si114x. If any I²C register or parameter has already been written to the Si114x when the I²C Broadcast Reset is issued, the host must send a reset command and reinitialize the Si114x completely.

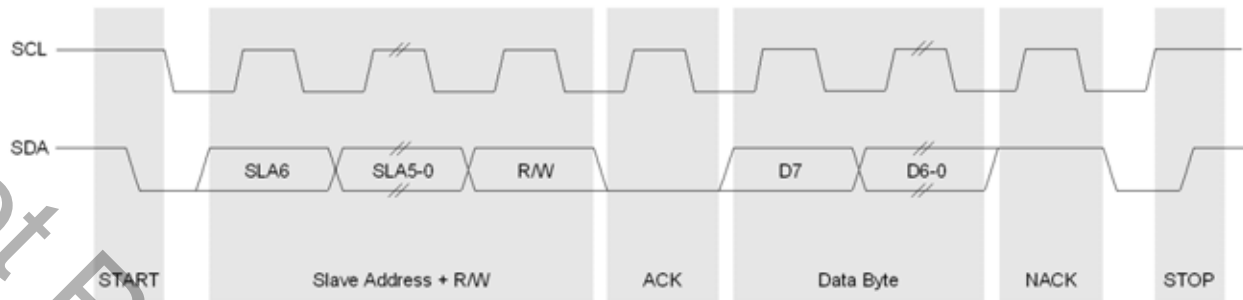

Figure 8. I²C Bit Timing Diagram



Figure 9. Host Interface Single Write

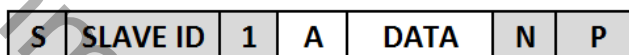

Figure 10. Host Interface Single Read



Figure 11. Host Interface Burst Write

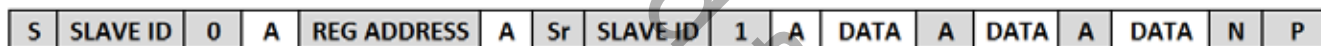

Figure 12. Host Interface Burst Read

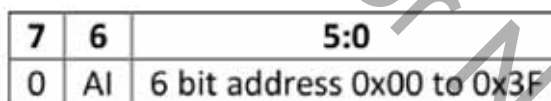

Figure 13. Si1141/42/43 REG ADDRESS Format

Notes:

- Gray boxes are driven by the host to the Si1141/42/43
- White boxes are driven by the Si1141/42/43 to the host
- A = ACK or “acknowledge”
- N = NACK or “no acknowledge”
- S = START condition
- Sr = repeat START condition
- P = STOP condition
- AI = Disable Auto Increment when set

3. Operational Modes

The Si1141/42/43 can be in one of many operational modes at any one time. It is important to consider the operational mode since the mode has an impact on the overall power consumption of the Si1141/42/43. The various modes are:

- Off Mode
- Initialization Mode
- Standby Mode
- Forced Conversion Mode
- Autonomous Mode

3.1. Off Mode

The Si1141/42/43 is in the Off Mode when V_{DD} is either not connected to a power supply or if the V_{DD} voltage is below the stated V_{DD_OFF} voltage described in the electrical specifications. As long as the parameters stated in Table 4, “Absolute Maximum Limits,” on page 9 are not violated, no current will flow through the Si1141/42/43. In the Off Mode, the Si1141/42/43 SCL and SDA pins do not interfere with other I²C devices on the bus. The LED pins will not draw current through the infrared diodes. Keeping V_{DD} less than V_{DD_OFF} is not intended as a method of achieving lowest system current draw. The reason is that the ESD protection devices on the SCL, SDA and INT pins also form a current path through V_{DD} . If V_{DD} is grounded for example, then, current flow from system power to system ground through the SCL, SDA and INT pull-up resistors and the ESD protection devices.

Allowing V_{DD} to be less than V_{DD_OFF} is intended to serve as a hardware method of resetting the Si1141/42/43 without a dedicated reset pin.

The Si1141/42/43 can also reenter the Off Mode upon receipt of either a general I²C reset or if a software reset sequence is initiated. When one of these software methods is used to enter the Off Mode, the Si1141/42/43 typically proceeds directly from the Off Mode to the Initialization Mode.

3.2. Initialization Mode

When power is applied to V_{DD} and is greater than the minimum V_{DD} Supply Voltage stated in Table 1, “Recommended Operating Conditions,” on page 4, the Si1141/42/43 enters its Initialization Mode. In the Initialization Mode, the Si1141/42/43 performs its initial startup sequence. Since the I²C may not yet be active, it is recommended that no I²C activity occur during this brief Initialization Mode period. The “Start-up time” specification in Table 1 is the minimum recommended time the host needs to wait before sending any I²C accesses following a power-up sequence. After Initialization Mode has completed, the Si1141/42/43 enters Standby Mode. The host must write 0x17 to the HW_KEY register for proper operation.

3.3. Standby Mode

The Si1141/42/43 spends most of its time in Standby Mode. After the Si1141/42/43 completes the Initialization Mode sequence, it enters Standby mode. While in Standby Mode, the Si1141/42/43 does not perform any Ambient Light measurements or Proximity Detection functions. However, the I²C interface is active and ready to accept reads and writes to the Si1141/42/43 registers. The internal Digital Sequence Controller is in its sleep state and does not draw much power. In addition, the INT output retains its state until it is cleared by the host.

I²C accesses do not necessarily cause the Si1141/42/43 to exit the Standby Mode. For example, reading Si1141/42/43 registers is accomplished without needing the Digital Sequence Controller to wake from its sleep state.

3.4. Forced Conversion Mode

The Si1141/42/43 can operate in Forced Conversion Mode under the specific command of the host processor. The Forced Conversion Mode is entered if either the ALS_FORCE or the PS_FORCE command is sent. Upon completion of the conversion, the Si1141/42/43 can generate an interrupt to the host if the corresponding interrupt is enabled. It is possible to initiate both an ALS and multiple PS measurements with one command register write access by using the PSALS_FORCE command.

3.5. Autonomous Operation Mode

The Si1141/42/43 can be placed in the Autonomous Operation Mode where measurements are performed automatically without requiring an explicit host command for every measurement. The PS_AUTO, ALS_AUTO and PSALS_AUTO commands are used to place the Si1141/42/43 in the Autonomous Operation Mode.

The Si1141/42/43 updates the I²C registers for PS and ALS automatically. Each measurement is allocated a 16-bit register in the I²C map. It is possible to operate the Si1141/42/43 without interrupts. When doing so, the host poll rate must be at least twice the frequency of the conversion rates for the host to always receive a new measurement. The host can also choose to be notified when these new measurements are available by enabling interrupts.

The conversion frequencies for the PS and ALS measurements are set up by the host prior to the PS_AUTO, ALS_AUTO, or PSALS_AUTO commands. The host can set a PS conversion frequency different from the ALS conversion frequency. However, they both need to be a multiple of the base conversion frequency in the MEAS_RATE register in the I²C map.

The Si1141/42/43 can interrupt the host when the PS or ALS measurements reach a pre-set threshold. To assist in the handling of interrupts the registers are arranged so that the interrupt handler can perform an I²C burst read operation to read the necessary registers, beginning with the interrupt status register, and cycle through the ALS data registers followed by the individual Proximity readings.

3.6. ALWAYS_ACTIVE Mode

In autonomous measurements mode, the device enters sleep mode during the measurement interval. If the device is configured as ALWAYS_ACTIVE, the device does not enter sleep mode. This mode is added as a workaround to the “unexpected internal reset issue”. Details on this issue are described in Section “3.7. Avoiding an Unexpected Reset” of this document.

To enter ALWAYS_ACTIVE mode, set Parameter 0x1B = 0x01 before enabling autonomous measurements. Setting Parameter 0x1B = 0x81 returns the device in “Normal Mode”. A side effect of this setting is that total power consumption will be higher due to ALWAYS_ACTIVE.

3.7. Avoiding an Unexpected Reset

If an internal wakeup event is generated less than 250 µsec after entering sleep mode, the Si114x may generate an internal reset that returns the chip to a default state. This unexpected reset issue will not occur if an application code follows the information provided in this data sheet and summarized here.

The Si114x has only two wakeup sources:

- MEAS_RATE timer in autonomous mode
- I2C write to 0x18(COMMAND register).

Examples of problem setups include:

- An interval shorter than 250 µsec (MEAS_RATE < 0x24) in autonomous mode with PS only.
- An interval shorter than “250 µsec + ALS/VIS/IR measurement (active) period” in autonomous mode with PS+ ALS/VIS/IR.
- An I²C write to 0x18 (COMMAND) received right after entering sleep mode

This issue is avoided by using ALWAYS_ACTIVE mode because you never enter sleep mode. Set Parameter 0x1B to 0x01 (ALWAYS_ACTIVE mode) before enabling autonomous measurements. A side effect of this setting is that total power consumption will be higher due to ALWAYS_ACTIVE mode. This issue is avoided in Normal Mode by preventing wakeup events from being triggered immediately upon entering sleep state. Some points to consider are:

1. Follow minimum MEASRATE restriction in table.
2. Prior to sending an I²C Command, check that prior commands have completed:
 - Check if CHIPSTAT == 0x01 as implemented in sample code, or
 - Check RESPONSE counter increment as documented here

3. Use the following procedure to exit autonomous operation
 - a. Write MEASRATE=0x00 to stop autonomous measurements
 - b. Wait two complete measurement periods. For example, if INT pin pulses are observed every 750 μ s, the waiting period would be 1500 μ s. The measurement period must be determined by checking the INT pin pulses on the oscilloscope or by using system timers to time the arrival of incoming samples in the interrupt handler.
 - c. When using forced measurements, after sending the Force command, don't send any other I²C commands until after measurements have been retrieved. (Forced measurements are completed when INT pin asserts or when IRQSTATUS is non-zero).

Not Recommended for New Designs

4. Programming Guide

4.1. Command and Response Structure

All Si1141/42/43 I²C registers (except writes to the COMMAND register) are read or written without waking up the internal sequencer. A complete list of the I²C registers can be found in "4.6. I2C Registers" on page 30. In addition to the I²C Registers, RAM parameters are memory locations maintained by the internal sequencer. These RAM Parameters are accessible through a Command Protocol (see "4.7. Parameter RAM" on page 54). A complete list of the RAM Parameters can be found in "4.7. Parameter RAM" on page 54.

The Si1141/42/43 can operate either in Forced Measurement or Autonomous Mode. When in Forced Measurement mode, the Si1141/42/43 does not make any measurements unless the host specifically requests the Si1141/42/43 to do so via specific commands (refer to the Section 3.2). The CHLIST parameter needs to be written so that the Si1141/42/43 would know which measurements to make. The parameter MEAS_RATE, when zero, places the internal sequencer in Forced Measurement mode. When in Forced Measurement mode, the internal sequencer wakes up only when the host writes to the COMMAND register. The power consumption is lowest in Forced Measurement mode (MEAS_RATE = 0).

The Si1141/42/43 operates in Autonomous Operation mode when MEAS_RATE is non-zero. The MEAS_RATE represents the time interval at which the Si1141/42/43 wakes up periodically. Once the internal sequencer has awoken, the sequencer manages an internal PS Counter and ALS Counter based on the PS_RATE and ALS_RATE registers.

When the internal PS counter has expired, up to three proximity measurements are made (PS1, PS2 and PS3) depending on which measurements are enabled via the upper bits of the CHLIST Parameter. All three PS measurements are performed, in sequence, beginning with the PS1 measurement channel. In the same way, when the ALS counter has expired, up to three measurements are made (ALS_VIS, ALS_IR and AUX) depending on which measurements are enabled via the upper bits of the CHLIST Parameter. All three measurements are made in the following sequence: ALS_VIS, ALS_IR and AUX.

PS_RATE and ALS_RATE are normally non-zero. A value of zero in PS_RATE or ALS_RATE causes the internal sequencer to never perform that measurement group. Typically, PS_RATE or ALS_RATE represents a value of one. A value of one essentially states that the specific measurement group is made every time the device wakes up.

It is possible for both the PS Counter and ALS Counter to both expire at the same time. When that occurs, the PS measurements are performed before the ALS measurements. When all measurements have been made, the internal sequencer goes back to sleep until next time, as dictated by the MEAS_RATE parameter.

The operation of the Si1141/42/43 can be described as two measurement groups bound by some common factors. The PS Measurement group consists of the three PS measurements while the ALS Measurement group consists of the Visible Light Ambient Measurement (ALS_VIS), the Infrared Light Ambient Measurement (ALS_IR) and the Auxiliary measurement (AUX). Each measurement group has three measurements each. The Channel List (CHLIST) parameter enables the specific measurements for that measurement grouping.

Each measurement (PS1, PS2, PS3, ALS_VIS, ALS_IR, AUX) are controlled through a combination of I2C Register or Parameter RAM. Tables 7 to 9 below summarize the properties and resources used for each measurement.

4.2. Command Protocol

The I²C map implements a bidirectional message box between the host and the Si1141/42/43 Sequencer. Host-writable I²C registers facilitate host-to-Si1141/42/43 communication, while read-only I²C registers are used for Si1141/42/43-to-host communication.

Unlike the other host-writable I²C registers, the COMMAND register causes the internal sequencer to wake up from Standby mode to process the host request.

When a command is executed, the RESPONSE register is updated. Typically, when there is no error, the upper four bits are zeroes. To allow command tracking, the lower four bits implement a 4-bit circular counter. In general, if the upper nibble of the RESPONSE register is non-zero, this indicates an error or the need for special processing.

The PARAM_WR and PARAM_RD registers are additional mailbox registers.

In addition to the registers in the I²C map, there are environmental parameters accessible through the Command/Response interface. These parameters are stored in the internal ram space. These parameters generally take more I²C accesses to read and write. The Parameter RAM is described in "4.7. Parameter RAM" on page 54.

For every write to the Command register, the following sequence is required:

1. Write 0x00 to Command register to clear the Response register.
2. Read Response register and verify contents are 0x00.
3. Write Command value from Table 5 into Command register.
4. Read the Response register and verify contents are now non-zero. If contents are still 0x00, repeat this step.

Note: Step 4 is not applicable to the Reset Command because the device will reset itself and does not increment the Response register after reset. No Commands should be issued to the device for at least 1 ms after a Reset is issued.

The Response register will be incremented upon the successful completion of a Command. If the Response register remains 0x00 for over 25 ms after the Command write, the entire Command process should be repeated from Step 1.

Table 5. Command Register Summary

COMMAND Register		PARAM_W R Register	PARAM_RD Register	Error Code in RESPONSE Register	Description
Name	Encoding				
PARAM_QUERY	100 aaaaa	—	nnnn nnnn	✓	Reads the parameter pointed to by bitfield [4:0] and writes value to PARAM_RD. See Table 16 for parameters.
PARAM_SET	101 aaaaa	dddd dddd	nnnn nnnn	✓	Sets parameter pointed by bitfield [4:0] with value in PARAM_WR, and writes value out to PARAM_RD. See Table 16 for parameters.
PARAM_AND	110 aaaaa	dddd dddd	nnnn nnnn	✓	Performs a bit-wise AND between PARAM_WR and Parameter pointed by bitfield [4:0], writes updated value to PARAM_RD. See Table 16 for parameters.

Table 5. Command Register Summary (Continued)

COMMAND Register		PARAM_W R Register	PARAM_RD Register	Error Code in RESPONSE Register	Description
Name	Encoding				
PARAM_OR	111 aaaaa	dddd dddd	nnnn nnnn	✓	Performs a bit-wise OR of PARAM_WR and parameter pointed by bitfield [4:0], writes updated value to PARAM_RD. See Table 16 for parameters.
NOP	000 00000	—	—	✓	Forces a zero into the RESPONSE register
RESET	000 00001	—	—	✓	Performs a software reset of the firmware
BUSADDR	000 00010	—	—	—	Modifies I ² C address
Reserved	000 00011	—	—	—	—
Reserved	000 00100	—	—	—	—
PS_FORCE	000 00101	—	—	✓	Forces a single PS measurement
ALS_FORCE	000 00110	—	—	✓	Forces a single ALS measurement
PSALS_FORCE	000 00111	—	—	✓	Forces a single PS and ALS measurement
Reserved	000 01000	—	—	—	—
PS_PAUSE	000 01001	—	—	✓	Pauses autonomous PS
ALS_PAUSE	000 01010	—	—	✓	Pauses autonomous ALS
PSALS_PAUSE	000 01011	—	—	✓	Pauses PS and ALS
Reserved	000 01100	—	—	✓	—
PS_AUTO	000 01101	—	—	✓	Starts/Restarts an autonomous PS Loop
ALS_AUTO	000 01110	—	—	✓	Starts/Restarts an autonomous ALS Loop
PSALS_AUTO	000 01111	—	—	✓	Starts/Restarts autonomous ALS and PS loop
Reserved	000 1xxxx	—	—	—	—

Table 6. Response Register Error Codes

RESPONSE Register	Description
0000 cccc	NO_ERROR. The lower bit is a circular counter and is incremented every time a command has completed. This allows the host to keep track of commands sent to the Si1141/42/43. The circular counter may be cleared using the NOP command.
1000 0000	INVALID_SETTING. An invalid setting was encountered. Clear using the NOP command.
1000 1000	PS1_ADC_OVERFLOW. Indicates proximity channel one conversion overflow.
1000 1001	PS2_ADC_OVERFLOW. Indicates proximity channel two conversion overflow.
1000 1010	PS3_ADC_OVERFLOW. Indicates proximity channel three conversion overflow.
1000 1100	ALS_VIS_ADC_OVERFLOW. Indicates visible ambient light channel conversion overflow.
1000 1101	ALS_IR_ADC_OVERFLOW. Indicates infrared ambient light channel conversion overflow.
1000 1110	AUX_ADC_OVERFLOW. Indicates auxiliary channel conversion overflow.

4.3. Command Write Timing Limitations

Commands should not be sent immediately after the Si114x enters sleep mode. Consider the following scenarios:

1. Prior to sending any I²C commands, the software needs to check that prior commands have been completed. The software will verify that the CHIPSTAT == 0x01, as implemented in sample code, or the RESPONSE counter increment, as documented in the data sheet and application note.
2. Use the following procedure to exit autonomous operation instead of a PAUSE command (any commands including PAUSE should not be addressed during autonomous operation):
 - Write MEASRATE = 0x00 to stop autonomous measurements
 - Wait two complete measurement periods (for example, if INT pin pulses are observed every 750 μ s, the waiting period would be 1500 μ s). The measurement period must be determined by checking the INT pin pulses on the oscilloscope or by using system timers to time the arrival of incoming samples in the interrupt handler.
3. When using Forced measurements, do not send any other I²C commands until after the measurements have been retrieved. Forced measurements are completed when the INT pin asserts or when IRQSTATUS becomes non-zero.

4.4. Resource Summary

Table 7. Resource Summary for Interrupts and Threshold Checking

Measurement Channel	Channel Enable	Interrupt Status Output	Interrupt Enable	Interrupt Mode	Threshold Registers	Threshold Hysteresis	History Checking
Proximity Sense 1	EN_PS 1 in CHLIST [0]	PS1_INT in IRQ_STA- TUS[2]	PS1_IE in IRQ_EN- ABLE[2]	PS1_IM[1:0] in IRQ_ MODE1[5:4]	PS1_TH[7:0]	PS_HYST[7: 0]	PS_HIS- TORY[7:0]
Proximity Sense 2	EN_PS 2 in CHLIST [1]	PS2_INT in IRQ_STA- TUS[3]	PS2_IE in IRQ_EN- ABLE[3]	PS2_IM[1:0] in IRQ_ MODE1[7:6]	PS2_TH[7:0]		
Proximity Sense 3	EN_PS 3 in CHLIST [2]	PS3_INT in IRQ_STA- TUS[4]	PS3_EN in IRQ_EN- ABLE[4]	PS3_IM[1:0] in IRQ_ MODE2[1:0]	PS3_TH[7:0]		
ALS Visible	EN_AL S_VIS in CHLIST [4]	ALS_INT[1:0] in IRQ_STA- TUS[1:0]	ALS_IE[1:0] in IRQ_EN- ABLE[1:0]	ALS_IM[2:0] in IRQ_ MODE1[2:0]	ALS_LOW_TH[7: 0] / ALS_HI_TH[7:0]	ALS_HYST[7: 0]	ALS_HIS- TORY[7:0]
ALS IR	EN_AL S_IR in CHLIST [5]						
Auxiliary Measurement	EN_AU X in CHLIST [6]						

Table 8. Resource Summary for LED Choice and ADC Parameters

Measurement Channel	LED Selection	ADC Mode	ADC Output	ADC Input Source	ADC Recovery Count	ADC High Signal Mode	ADC Clock Divider
Proximity Sense 1	PS1_LED[2:0] in PSLED12_SELECT[2:0]	PS_ADC_MODE in PS_ADC_MISC[2]	PS1_DATA1[7:0] / PS1_DATA0[7:0]	PS1_ADC_MUX[7:0]	PS_ADC_REC in PS_ADC_COUNTER [6:4]	PS_RANGE in PS_ADC_MISC[5]	PS_AD_C_GAIN[3:0]
	Proximity Sense 2	PS2_LED[2:0] in PSLED12_SELECT[6:4]	PS2_DATA1[7:0] / PS2_DATA0[7:0]	PS2_ADC_MUX[7:0]			
Proximity Sense 3	PS3_LED[2:0] in PSLED3_SELECT[2:0]		PS3_DATA1[7:0] / PS3_DATA0[7:0]	PS3_ADC_MUX[7:0]			
ALS Visible	—	—	ALS_VIS_DATA1 / ALS_VIS_DATA0		VIS_ADC_REC in ALS_VIS_ADC_COUNTER [6:4]	VIS_RANGE in ALS_VIS_ADC_MISC[5]	ALS_VIS_ADC_GAIN [3:0]
			ALS_IR_DATA1[7:0] / ALS_IR_DATA0[7:0]				
ALS IR	—	—	AUX_DATA1[7:0] / AUX_DATA0[7:0]	AUX_ADC_MUX[7:0]	—	—	ALS_IR_ADC_GAIN [3:0]
Auxiliary Measurement							

Table 9. Resource Summary for Hardware Pins

Pin Name	LED Current Drive	Output Drive Disable	Analog Voltage Input Enable
LED1	LED1_I in PSLED12[3:0]		ANA_IN_KEY[31:0]
LED2	LED2_I in PSLED12[7:4]	HW_KEY[7:0]	ANA_IN_KEY[31:0]
LED3	LED3_I in PSLED3[3:0]	HW_KEY[7:0]	
INT		INT_OE in INT_CFG[0]	ANA_IN_KEY[31:0]

The interrupts of the Si1141/42/43 are controlled through the INT_CFG, IRQ_ENABLE, IRQ_MODE1, IRQ_MODE2 and IRQ_STATUS registers.

The INT hardware pin is enabled through the INT_OE bit in the INT_CFG register. The hardware essentially performs an AND function between the IRQ_ENABLE register and IRQ_STATUS register. After this AND function, if any bits are set, the INT pin is asserted. The INT_MODE bit in the INT_CFG register is conceptually a method of determining how the INT pin is deasserted. When INT_MODE = 0, the host is responsible for clearing the interrupt by writing to the IRQ_STATUS register. When the specific bits of the IRQ_STATUS register is written with '1', that specific IRQ_STATUS bit is cleared.

Typically, the host software is expected to read the IRQ_STATUS register, stores a local copy, and then writes the same value back to the IRQ_STATUS to clear the interrupt source. Unless specifically stated, INT_MODE should be zero for normal interrupt handling operation. In summary, the INT_CFG register is normally written with '1'.

The IRQ_MODE1, IRQ_MODE2 and IRQ_ENABLE registers work together to define how the internal sequencer sets bits in the IRQ_STATUS register (and as a consequence, asserting the INT pin).

The PS1 interrupts are described in Table 10. The PS2 interrupts are described in Table 11. The PS3 interrupts are described in Table 12. The ALS interrupts are described in Table 13, and the Command Interface interrupts are described in Table 14.

Table 10. PS1 Channel Interrupt Resources

IRQ_ENABLE[2]	IRQ_MODE1[5:4]		Description
PS1_IE	PS1_IM[1:0]		
0	0	0	No PS1 Interrupts
1	0	0	PS1_INT set after every PS1 sample
1	0	1	PS1_INT set whenever PS1 threshold (PS1_TH) is crossed
1	1	1	PS1_INT set whenever PS1 sample is above PS1 threshold (PS1_TH)

Note: There is hysteresis applied (PS_HYST) and history checking (PS_HISTORY). PS_HYST is encoded in 8-bit compressed format. In the Si114x, PS1_TH is also encoded in compressed format.

Table 11. PS2 Channel Interrupt Resources

IRQ_ENABLE[3]	IRQ_MODE1[7:6]		Description
PS2_IE	PS2_IM[1:0]		
0	0	0	No PS2 Interrupts
1	0	0	PS2_INT set after every PS2 sample
1	0	1	PS2_INT set whenever PS2 threshold (PS2_TH) is crossed
1	1	1	PS2_INT set when PS2 sample is above PS2 threshold (PS2_TH)

Note: There is hysteresis applied (PS_HYST) and history checking (PS_HISTORY). PS_HYST is encoded in 8-bit compressed format. In the Si114x, PS2_TH is also encoded in compressed format.

Table 12. PS3 Channel Interrupt Resources

IRQ_ENABLE[4]	IRQ_MODE2[1:0]		Description
PS3_IE	PS3_IM[1:0]		
0	0	0	No PS3 Interrupts
1	0	0	PS3_INT set after every PS3 sample
1	0	1	PS3_INT set whenever PS3 threshold (PS3_TH) is crossed
1	1	1	PS3_INT set whenever PS3 sample is above PS3 threshold (PS3_TH)

Note: There is hysteresis applied (PS_HYST) and history checking (PS_HISTORY). PS_HYST is encoded in 8-bit compressed format. In the Si114x, PS3_TH is also encoded in compressed format.

Table 13. Ambient Light Sensing Interrupt Resources

IRQ_ENABLE[1:0]		IRQ_MODE1[2:0]			Description
ALS_IE[1:0]		ALS_IM[2:0]			
0	0	0	0	0	No ALS Interrupts
0	1	0	0	0	ALS_INT [0] set after every ALS_VIS sample ¹
x	1	x	0	1	Monitors ALS_VIS, ALS_INT [0] upon exiting region between low and high thresholds (ALS_LOW_TH and ALS_HI_TH)
1	x	1	0	x	Monitors ALS_VIS, ALS_INT [1] set upon entering region between low and high thresholds (ALS_LOW_TH and ALS_HI_TH)
x	1	x	1	1	Monitors ALS_IR, ALS_INT [0] set upon exiting region between low and high thresholds (ALS_LOW_TH and ALS_HI_TH)
1	x	1	1	x	Monitors ALS_IR, ALS_INT [1] set upon entering region between low and high thresholds (ALS_LOW_TH and ALS_HI_TH)

Notes:

1. For ALS_IR channel, interrupts per sample is not possible without also enabling ALS_VIS
2. All other combinations are invalid and may result in unintended operation
3. There is hysteresis applied (ALS_TH) and history checking (ALS_HISTORY). ALS_HYST is encoded in 8-bit compressed format.
4. In the Si114x, ALS_LOW_TH and ALS_HI_TH are also encoded in compressed format.

Table 14. Command Interrupt Resources

IRQ_ENABLE[5]	IRQ_MODE2[3:2]		Description
CMD_IE	CMD_IM[1:0]		
0	x	0	No CMD Interrupts
1	x	0	CMD_INT set when there is a new RESPONSE
1	x	1	CMD_INT set when there is a new error code in RESPONSE

4.5. Signal Path Software Model

The following diagram gives an overview of the signal paths, along with the I²C register and RAM Parameter bit fields that control them. Sections with detailed descriptions of the I²C registers and Parameter RAM follow.

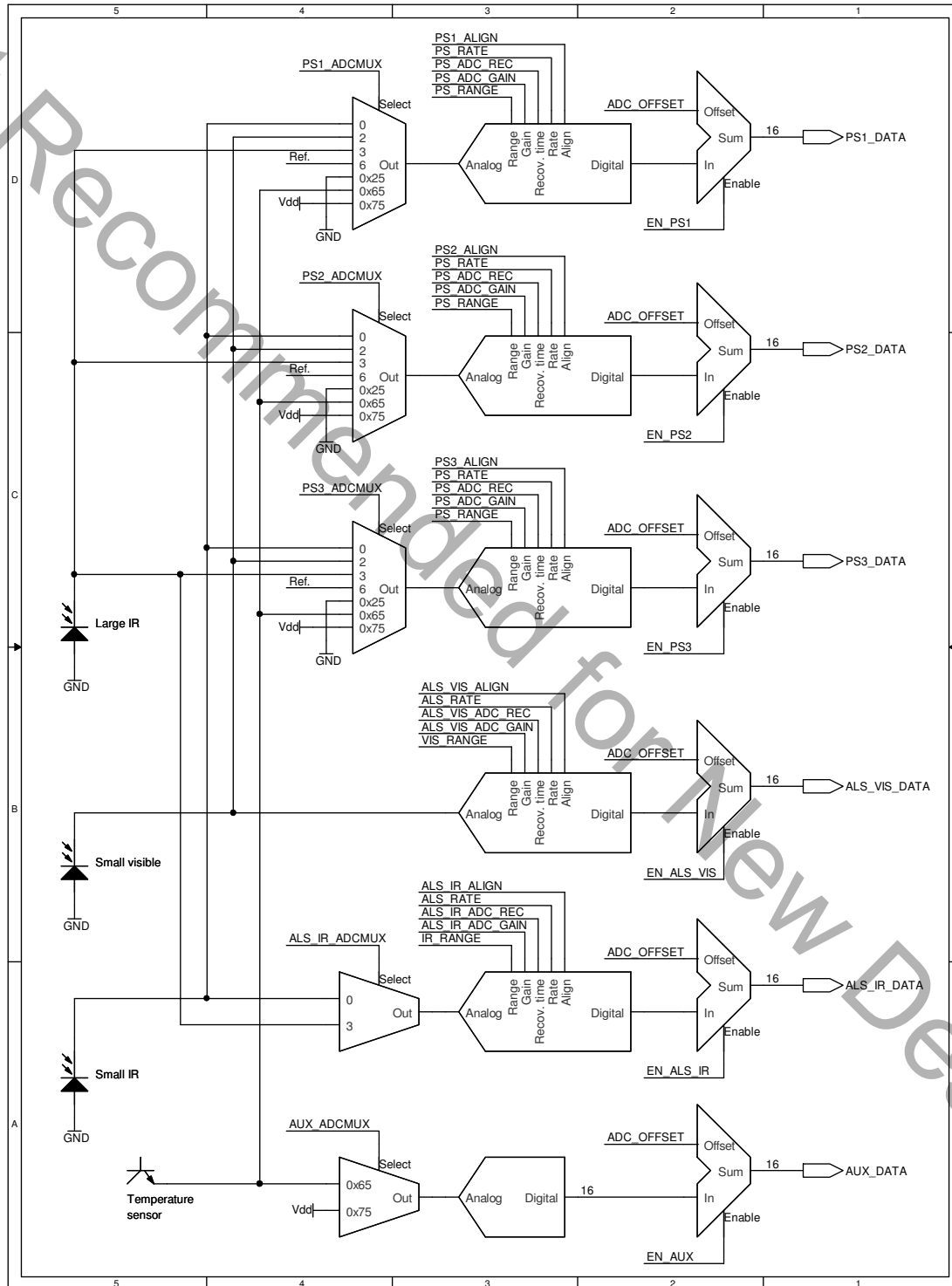

Figure 14. Signal Path Programming Model

4.6. I²C Registers

Table 15. I²C Register Summary

I ² C Register Name	Address	7	6	5	4	3	2	1	0
PART_ID	0x00	PART_ID							
REV_ID	0x01	REV_ID							
SEQ_ID	0x02	SEQ_ID							
INT_CFG	0x03							INT_MODE	INT_OE
IRQ_ENABLE	0x04			CMD_IE	PS3_IE	PS2_IE	PS1_IE	ALS_IE	
IRQ_MODE1	0x05	PS2_IM		PS1_IM			ALS_IM		
IRQ_MODE2	0x06					CMD_IM		PS3_IM	
HW_KEY	0x07	HW_KEY							
MEAS_RATE	0x08	MEAS_RATE							
ALS_RATE	0x09	ALS_RATE							
PS_RATE	0x0A	PS_RATE							
ALS_LOW_TH0	0x0B	ALS_LOW_TH0							
ALS_LOW_TH1	0x0C	ALS_LOW_TH1							
ALS_HI_TH0	0x0D	ALS_HI_TH0							
ALS_HI_TH1	0x0E	ALS_HI_TH1							
PS_LED21	0x0F	LED2_I				LED1_I			
PS_LED3	0x10					LED3_I			
PS1_TH0	0x11	PS1_TH0							
PS1_TH1	0x12	PS1_TH1							
PS2_TH0	0x13	PS2_TH0							
PS2_TH1	0x14	PS2_TH1							
PS3_TH0	0x15	PS3_TH0							
PS3_TH1	0x16	PS3_TH1							
PARAM_WR	0x17	PARAM_WR							
COMMAND	0x18	COMMAND							
RESPONSE	0x20	RESPONSE							

Table 15. I²C Register Summary (Continued)

I ² C Register Name	Address	7	6	5	4	3	2	1	0
IRQ_STATUS	0x21			CMD_IN T	PS3_IN T	PS2_IN T	PS1_IN T	ALS_INT	
ALS_VIS_DATA0	0x22	ALS_VIS_DATA0							
ALS_VIS_DATA1	0x23	ALS_VIS_DATA1							
ALS_IR_DATA0	0x24	ALS_IR_DATA0							
ALS_IR_DATA1	0x25	ALS_IR_DATA1							
PS1_DATA0	0x26	PS1_DATA0							
PS1_DATA1	0x27	PS1_DATA1							
PS2_DATA0	0x28	PS2_DATA0							
PS2_DATA1	0x29	PS2_DATA1							
PS3_DATA0	0x2A	PS3_DATA0							
PS3_DATA1	0x2B	PS3_DATA1							
AUX_DATA0	0x2C	AUX_DATA0							
AUX_DATA1	0x2D	AUX_DATA1							
PARAM_RD	0x2E	PARAM_RD							
CHIP_STAT	0x30						RUN- NING	SUS- PEND	SLEEP
ANA_IN_KEY	0x3B– 0x3E	ANA_IN_KEY							

Si1141/42/43

PART_ID @ 0x00

Bit	7	6	5	4	3	2	1	0
Name	PART_ID							
Type	R							

Reset value = 0100 0001 (Si1141)

Reset value = 0100 0010 (Si1142)

Reset value = 0100 0011 (Si1143)

REV_ID @ 0x1

Bit	7	6	5	4	3	2	1	0
Name	REV_ID							
Type	R							

Reset value = 0000 0000

SEQ_ID @ 0x02

Bit	7	6	5	4	3	2	1	0
Name	SEQ_ID							
Type	R							

Reset value = 0000 1000

Bit	Name	Function
7:0	SEQ_ID	Sequencer Revision. 0x01 Si114x-A01 (MAJOR_SEQ = 0, MINOR_SEQ = 1) 0x02 Si114x-A02 (MAJOR_SEQ = 0, MINOR_SEQ = 2) 0x03 Si114x-A03 (MAJOR_SEQ = 0, MINOR_SEQ = 3) 0x08 Si114x-A10 (MAJOR_SEQ = 1, MINOR_SEQ = 0) 0x09 Si114x-A11 (MAJOR_SEQ = 1, MINOR_SEQ = 1)

INT_CFG @ 0x03

Bit	7	6	5	4	3	2	1	0
Name							INT_MODE	INT_OE
Type							RW	RW

Reset value = 0000 0000

Bit	Name	Function
7:2	Reserved	Reserved.
1	INT_MODE	Interrupt Mode. The INT_MODE describes how the bits in the IRQ_STATUS Registers are cleared. 0: The IRQ_STATUS Register bits are set by the internal sequencer and are sticky. It is the host's responsibility to clear the interrupt status bits in the IRQ_STATUS register to clear the interrupt. 1: If the Parameter Field PSx_IM = 11, the internal sequencer clears the INT pin automatically.
0	INT_OE	INT Output Enable. INT_OE controls the INT pin drive 0: INT pin is never driven 1: INT pin driven low whenever an IRQ_STATUS and its corresponding IRQ_ENABLE bits match

Si1141/42/43

IRQ_ENABLE @ 0x04

Bit	7	6	5	4	3	2	1	0
Name			CMD_IE	PS3_IE	PS2_IE	PS1_IE	ALS_IE	
Type			RW	RW	RW	RW	RW	

Reset value = 0000 0000

Bit	Name	Function
7:6	Reserved	Reserved.
5	CMD_IE	Command Interrupt Enable. Enables interrupts based on COMMAND/RESPONSE activity. 0: INT never asserts due to COMMAND/RESPONSE interface activity. 1: Assert INT pin whenever CMD_INT is set by the internal sequencer.
4	PS3_IE	PS3 Interrupt Enable. Enables interrupts based on PS3 Channel Activity. 0: INT never asserts due to PS3 Channel activity. 1: Assert INT pin whenever PS3_INT is set by the internal sequencer.
3	PS2_IE	PS2 Interrupt Enable. Enables interrupts based on PS2 Channel Activity. 0: INT never asserts due to PS2 Channel activity. 1: Assert INT pin whenever PS2_INT is set by the internal sequencer.
2	PS1_IE	PS1 Interrupt Enable. Enables interrupts based on PS1 Channel Activity. 0: INT never asserts due to PS1 Channel activity. 1: Assert INT pin whenever PS1_INT is set by the internal sequencer.
1:0	ALS_IE	ALS Interrupt Enable. Enables interrupts based on ALS Activity. 00: INT never asserts due to ALS activity. 1x: Assert INT pin whenever ALS_INT[1] bit is set by the internal sequencer. x1: Assert INT pin whenever ALS_INT[0] is set by the internal sequencer.

IRQ_MODE1 @ 0x05

Bit	7	6	5	4	3	2	1	0	
Name	PS2_IM		PS1_IM					ALS_IM	
Type	RW		RW					RW	

Reset value = 0000 0000

Bit	Name	Function
7:6	PS2_IM	PS2 Interrupt Mode applies only when PS2_IE is also set. 00: PS2_INT is set whenever a PS2 measurement has completed. 01: PS2_INT is set whenever the current PS2 measurement crosses the PS2_TH threshold. 11: PS2_INT is set whenever the current PS2 measurement is greater than the PS2_TH threshold.
5:4	PS1_IM	PS1 Interrupt Mode applies only when PS1_IE is also set. 00: PS1_INT is set whenever a PS1 measurement has completed. 01: PS1_INT is set whenever the current PS1 measurement crosses the PS1_TH threshold. 11: PS1_INT is set whenever the current PS1 measurement is greater than the PS1_TH threshold.
3	Reserved	Reserved.
2:0	ALS_IM	ALS Interrupt Mode function is defined in conjunction with ALS_IE[1:0]. ALS_IE[1:0] / ALS_IM[2:0]: 00 / 000: Neither ALS_INT[1] nor ALS_INT[0] is ever set. 01 / 000: ALS_INT[0] sets after every ALS_VIS sample. x1 / x01: Monitors ALS_VIS channel, ALS_INT[0] asserts if measurement exits window between ALS_LOW_TH and ALS_HIGH_TH. x1 / x11: Monitors ALS_IR channel, ALS_INT[0] asserts if measurement exits window between ALS_LOW_TH and ALS_HIGH_TH. 1x / 10x: Monitors ALS_VIS channel, ALS_INT[1] asserts if measurement enters window between ALS_LOW_TH and ALS_HIGH_TH. 1x / 11x: Monitors ALS_IR channel, ALS_INT[1] asserts if measurement enters window between ALS_LOW_TH and ALS_HIGH_TH.
Note: The ALS_IM description applies only to sequencer revisions A03 or later.		

Si1141/42/43

IRQ_MODE2 @ 0x06

Bit	7	6	5	4	3	2	1	0
Name					CMD_IM		PS3_IM	
Type					RW		RW	

Reset value = 0000 0000

Bit	Name	Function
7:4	Reserved	Reserved.
3:2	CMD_IM	Command Interrupt Mode applies only when CMD_IE is also set. 00: CMD_INT is set whenever the RESPONSE register is written. 01: CMD_INT is set whenever the RESPONSE register is written with an error code (MSB set). 1x: Reserved.
1:0	PS3_IM	PS3 Interrupt Mode applies only when PS3_IE is also set. 00: PS3_INT is set whenever a PS3 measurement has completed. 01: PS3_INT is set whenever the current PS3 measurement crosses the PS3_TH threshold. 11: PS3_INT is set whenever the current PS3 measurement is greater than the PS3_TH threshold.

HW_KEY @ 0x07

Bit	7	6	5	4	3	2	1	0
Name	HW_KEY							
Type	RW							

Reset value = 0000 0000

Bit	Name	Function
7:0	HW_KEY	The system must write the value 0x17 to this register for proper Si114x operation.

MEAS_RATE @ 0x08

Bit	7	6	5	4	3	2	1	0
Name	MEAS_RATE							
Type	RW							

Reset value = 0000 0000

Bit	Name	Function
-----	------	----------

7:0	MEAS_RATE	<p>MEAS_RATE is an 8-bit compressed value representing a 16-bit integer. The duration time between wake-up periods where measurements are made are calculated by the following steps.</p> <ol style="list-style-type: none"> 1. A = decompress from 8-bit to 16-bit (as in application note, “AN498: Si114x Designer’s Guide”). 2. $B = \text{INT}((A-1)/2)$ 3. $\text{Meas Rate}(\mu\text{s}) = (B+2.5) * 62.5 \mu\text{s}$ <p>Calculation examples: 0x84: The device wakes up every approx. 10 ms 0x94: The device wakes up every approx. 20 ms 0xB9: The device wakes up every approx. 100 ms 0xDF: The device wakes up every approx. 496 ms 0xFF: The device wakes up every approx. 1.984 seconds</p> <p>When either ALS_VIS or ALS_IR are enabled, the MEASRATE should be limited according to the following table:</p> <table border="1" data-bbox="639 919 1318 1335"> <thead> <tr> <th>Larger of (VIS_ADC_GAIN or IR_ADCGAIN)</th> <th>MEASRATE to Use</th> </tr> </thead> <tbody> <tr> <td>0</td> <td>$\geq 0x38$</td> </tr> <tr> <td>1</td> <td>$\geq 0x3E$</td> </tr> <tr> <td>2</td> <td>$\geq 0x46$</td> </tr> <tr> <td>3</td> <td>$\geq 0x51$</td> </tr> <tr> <td>4</td> <td>$\geq 0x5E$</td> </tr> <tr> <td>5</td> <td>$\geq 0x6C$</td> </tr> <tr> <td>6</td> <td>$\geq 0x7B$</td> </tr> <tr> <td>7</td> <td>$\geq 0x8A$</td> </tr> </tbody> </table> <p>Additional Information:</p> <ul style="list-style-type: none"> ■ 0x00: Turns off any internal oscillator and disables autonomous measurement. Use this setting to achieve lowest V_{DD} current draw for systems making use of only forced measurements. ■ 0x01-0x23: These values are not allowed when PS only or no ALS_VIS or no ALS_IR. ■ 0x18-0x23: These values can be used in ALWAYS_ACTIVE mode. 	Larger of (VIS_ADC_GAIN or IR_ADCGAIN)	MEASRATE to Use	0	$\geq 0x38$	1	$\geq 0x3E$	2	$\geq 0x46$	3	$\geq 0x51$	4	$\geq 0x5E$	5	$\geq 0x6C$	6	$\geq 0x7B$	7	$\geq 0x8A$
Larger of (VIS_ADC_GAIN or IR_ADCGAIN)	MEASRATE to Use																			
0	$\geq 0x38$																			
1	$\geq 0x3E$																			
2	$\geq 0x46$																			
3	$\geq 0x51$																			
4	$\geq 0x5E$																			
5	$\geq 0x6C$																			
6	$\geq 0x7B$																			
7	$\geq 0x8A$																			

ALS_RATE @ 0x09

Bit	7	6	5	4	3	2	1	0
Name	ALS_RATE							
Type	RW							

Reset value = 0000 0000

Bit	Name	Function
7:0	ALS_RATE	<p>ALS_RATE is an 8-bit compressed value representing a 16-bit multiplier. This multiplier, in conjunction with the MEAS_RATE time, represents how often ALS Measurements are made. For a given ALS measurement period, MEAS_RATE should be as high as possible and ALS_RATE as low as possible in order to optimize power consumption.</p> <p>Example Values:</p> <p>0x00: Autonomous ALS Measurements are not made.</p> <p>0x08: ALS Measurements made every time the device wakes up. (0x0001 x timeValueOf(MEAS_RATE))</p> <p>0x32: ALS Measurements made every 10 times the device wakes up. (0x000A x timeValueOf(MEAS_RATE))</p> <p>0x69: ALS Measurements made every 100 times the device wakes up. (0x0064 x timeValueOf(MEAS_RATE))</p> <p>Please refer to "AN498: Si114x Designer's Guide", Section 5.4 "Compression Concept."</p>

PS_RATE @ 0x0A

Bit	7	6	5	4	3	2	1	0
Name	PS_RATE							
Type	RW							

Reset value = 0000 0000

Bit	Name	Function
7:0	PS_RATE	<p>PS_RATE is an 8-bit compressed value representing a 16-bit multiplier. This multiplier, in conjunction with the MEAS_RATE time, represents how often PS Measurements are made. For a given proximity measurement period, MEAS_RATE should be as high as possible and PS_RATE as low as possible in order to optimize power consumption.</p> <p>Example Values:</p> <p>0x00: Autonomous PS Measurements are not made</p> <p>0x08: PS Measurements made every time the device wakes up (0x0001 x timeValueOf(MEAS_RATE))</p> <p>0x32: PS Measurements made every 10 times the device wakes up (0x000A x timeValueOf(MEAS_RATE))</p> <p>0x69: PS Measurements made every 100 times the device wakes up (0x0064 x timeValueOf(MEAS_RATE))</p> <p>Please refer to “AN498: Si114x Designer’s Guide”, Section 5.4 “Compression Concept.”</p>

ALS_LOW_TH0: ALS_LOW_TH Data Word Low Byte @ 0x0B

Bit	7	6	5	4	3	2	1	0
Name	ALS_LOW_TH[7:0]							
Type	RW							

Reset value = 0000 0000

Bit	Name	Function
7:0	ALS_LOW_TH[7:0]	<p>ALS_LOW_TH is a 16-bit threshold value. When used in conjunction with ALS_HI_TH, it forms a window region applied to either ALS_VIS or ALS_IR measurements for interrupting the host. Once autonomous measurements have started, modification to ALS_LOW_TH should be preceded by an ALS_PAUSE or PSALS_PAUSE command. For revisions A10 and below, ALS_LOW_TH uses an 8-bit compressed format. Refer to “AN498: Si114x Designer’s Guide”, Section 5.4 “Compression Concept.”</p>

ALS_LOW_TH1:ALS_LOW_TH Data Word High Byte @ 0x0C

Bit	7	6	5	4	3	2	1	0
Name	ALS_LOW_TH[15:8]							
Type	RW							

Reset value = 0000 0000

Bit	Name	Function
7:0	ALS_LOW_TH[15:8]	ALS_LOW_TH is a 16-bit threshold value. When used in conjunction with ALS_HI_TH, it forms a window region applied to either ALS_VIS or ALS_IR measurements for interrupting the host. Once autonomous measurements have started, modification to ALS_LOW_TH should be preceded by an ALS_PAUSE or PSALS_PAUSE command. For revisions A10 and below, ALS_LOW_TH uses an 8-bit compressed format. Refer to "AN498: Si114x Designer's Guide", Section 5.4 "Compression Concept."

ALS_HI_TH0: ALS_HI_TH Data Word Low Byte @ 0x0D

Bit	7	6	5	4	3	2	1	0
Name	ALS_HI_TH[7:0]							
Type	RW							

Reset value = 0000 0000

Bit	Name	Function
7:0	ALS_HI_TH[7:0]	ALS_HI_TH is a 16-bit threshold value. When used in conjunction with ALS_LOW_TH, it forms a window region applied to either ALS_VIS or ALS_IR measurements for interrupting the host. Once autonomous measurements have started, modification to ALS_HI_TH should be preceded by an ALS_PAUSE or PSALS_PAUSE command. For revisions A10 and below, ALS_HI_TH uses an 8-bit compressed format. Refer to "AN498: Si114x Designer's Guide", Section 5.4 "Compression Concept."

Note: This register available for sequencer revisions A03 or later.

Reset value = 0000 0000

Bit	Name	Function
7:4	Reserved	Reserved.
3:0	LED3_I	LED3_I Represents the irLED current sunk by the LED3 pin during a PS measurement. See PS_LED21 Register for additional details. On the Si1141 and Si1142, these bits must be set to zero.

PS1_TH0: PS1_TH Data Word Low Byte @ 0x11

Bit	7	6	5	4	3	2	1	0
Name	PS1_TH[7:0]							
Type	RW							

Reset value = 0000 0000

Bit	Name	Function
7:0	PS1_TH[7:0]	PS1_TH is a 16-bit threshold value. It is compared to PS1 measurements during autonomous operation for interrupting the host. If the threshold register is updated while a measurement is in progress, it is possible that an invalid threshold will be applied if the first new threshold byte has been written and not the second. Remedies include ensuring no measurement during threshold updates and discarding measurements results immediately after threshold updates. Once autonomous measurements have started, modification to PS1_TH should be preceded by a PS_PAUSE or PSALS_PAUSE command. For Si114x revision A10 and below, PS1_TH uses an 8-bit compressed format at address 0x11. Refer to "AN498: Si114x Designer's Guide" Section 5.4 "Compression Concept."

PS1_TH1: PS1_TH Data Word High Byte @ 0x12

Bit	7	6	5	4	3	2	1	0
Name	PS1_TH[15:8]							
Type	RW							

Reset value = 0000 0000

Si1141/42/43

Bit	Name	Function
7:0	PS1_TH[15:8]	PS1_TH is a 16-bit threshold value. It is compared to PS1 measurements during autonomous operation for interrupting the host. If the threshold register is updated while a measurement is in progress, it is possible that an invalid threshold will be applied if the first new threshold byte has been written and not the second. Remedies include ensuring no measurement during threshold updates and discarding measurements results immediately after threshold updates. Once autonomous measurements have started, modification to PS1_TH should be preceded by a PS_PAUSE or PSALS_PAUSE command. For Si114x revision A10 and below, PS1_TH uses an 8-bit compressed format at address 0x11. Refer to "AN498: Si114x Designer's Guide" Section 5.4 "Compression Concept."

PS2_TH0: PS2_TH Data Word Low Byte @ 0x13

Bit	7	6	5	4	3	2	1	0
Name	PS2_TH[7:0]							
Type	RW							

Reset value = 0000 0000

Bit	Name	Function
7:0	PS2_TH[7:0]	PS2_TH is a 16-bit threshold value. It is compared to PS2 measurements during autonomous operation for interrupting the host. If the threshold register is updated while a measurement is in progress, it is possible that an invalid threshold will be applied if the first new threshold byte has been written and not the second. Remedies include ensuring no measurement during threshold updates and discarding measurements results immediately after threshold updates. Once autonomous measurements have started, modification to PS2_TH should be preceded by a PS_PAUSE or PSALS_PAUSE command. For Si114x revision A10 and below, PS2_TH uses an 8-bit compressed format at address 0x13. Refer to "AN498: Si114x Designer's Guide" Section 5.4 "Compression Concept."

PS2_TH1: PS2_TH Data Word High Byte @ 0x14

Bit	7	6	5	4	3	2	1	0
Name	PS2_TH[15:8]							
Type	RW							

Reset value = 0000 0000

Bit	Name	Function
7:0	PS2_TH[15:8]	PS2_TH is a 16-bit threshold value. It is compared to PS2 measurements during autonomous operation for interrupting the host. If the threshold register is updated while a measurement is in progress, it is possible that an invalid threshold will be applied if the first new threshold byte has been written and not the second. Remedies include ensuring no measurement during threshold updates and discarding measurements results immediately after threshold updates. Once autonomous measurements have started, modification to PS2_TH should be preceded by a PS_PAUSE or PSALS_PAUSE command. For Si114x revision A10 and below, PS2_TH uses an 8-bit compressed format at address 0x13. Refer to "AN498: Si114x Designer's Guide" Section 5.4 "Compression Concept."

PS3_TH0: PS3_TH Data Word Low Byte @ 0x15

Bit	7	6	5	4	3	2	1	0
Name	PS3_TH[7:0]							
Type	RW							

Reset value = 0000 0000

Bit	Name	Function
7:0	PS3_TH[7:0]	PS3_TH is a 16-bit threshold value. It is compared to PS3 measurements during autonomous operation for interrupting the host. If the threshold register is updated while a measurement is in progress, it is possible that an invalid threshold will be applied if the first new threshold byte has been written and not the second. Remedies include ensuring no measurement during threshold updates and discarding measurements results immediately after threshold updates. Once autonomous measurements have started, modification to PS3_TH should be preceded by a PS_PAUSE or PSALS_PAUSE command. For Si114x revision A10 and below, PS3_TH uses an 8-bit compressed format at address 0x15. Refer to "AN498: Si114x Designer's Guide" Section 5.4 "Compression Concept."

PS3_TH1: PS3_TH Data Word High Byte @ 0x16

Bit	7	6	5	4	3	2	1	0
Name	PS3_TH[15:8]							
Type	RW							

Reset value = 0000 0000

Bit	Name	Function
7:0	PS3_TH[15:8]	PS3_TH is a 16-bit threshold value. It is compared to PS3 measurements during autonomous operation for interrupting the host. If the threshold register is updated while a measurement is in progress, it is possible that an invalid threshold will be applied if the first new threshold byte has been written and not the second. Remedies include ensuring no measurement during threshold updates and discarding measurements results immediately after threshold updates. Once autonomous measurements have started, modification to PS3_TH should be preceded by a PS_PAUSE or PSALS_PAUSE command. For Si114x revision A10 and below, PS3_TH uses an 8-bit compressed format at address 0x15. Refer to "AN498: Si114x Designer's Guide" Section 5.4 "Compression Concept."

PARAM_WR @ 0x17

Bit	7	6	5	4	3	2	1	0
Name	PARAM_WR							
Type	RW							

Reset value = 0000 0000

Bit	Name	Function
7:0	PARAM_WR	Mailbox register for passing parameters from the host to the sequencer.

COMMAND @ 0x18

Bit	7	6	5	4	3	2	1	0
Name	COMMAND							
Type	RW							

Reset value = 0000 0000

Bit	Name	Function
7:0	COMMAND	COMMAND Register. The COMMAND Register is the primary mailbox register into the internal sequencer. Writing to the COMMAND register is the only I ² C operation that wakes the device from standby mode.

RESPONSE @ 0x20

Bit	7	6	5	4	3	2	1	0
-----	---	---	---	---	---	---	---	---

RESPONSE @ 0x20

Name	RESPONSE
Type	RW

Reset value = 0000 0000

Bit	Name	Function
7:0	RESPONSE	<p>The Response register is used in conjunction with command processing. When an error is encountered, the response register will be loaded with an error code. All error codes will have the MSB is set.</p> <p>The error code is retained until a RESET or NOP command is received by the sequencer. Other commands other than RESET or NOP will be ignored. However, any autonomous operation in progress continues normal operation despite any error.</p> <p>0x00–0x0F: No Error. Bits 3:0 form an incrementing roll-over counter. The roll over counter in bit 3:0 increments when a command has been executed by the Si114x. Once autonomous measurements have started, the execution timing of any command becomes non-deterministic since a measurement could be in progress when the COMMAND register is written. The host software must make use of the rollover counter to ensure that commands are processed.</p> <p>0x80: Invalid Command Encountered during command processing 0x88: ADC Overflow encountered during PS1 measurement 0x89: ADC Overflow encountered during PS2 measurement 0x8A: ADC Overflow encountered during PS3 measurement 0x8C: ADC Overflow encountered during ALS-VIS measurement 0x8D: ADC Overflow encountered during ALS-IR measurement 0x8E: ADC Overflow encountered during AUX measurement</p>

IRQ_STATUS @ 0x21

Bit	7	6	5	4	3	2	1	0
Name			CMD_INT	PS3_INT	PS2_INT	PS1_INT	ALS_INT	
Type			RW	RW	RW	RW	RW	

Si1141/42/43

Reset value = 0000 0000

Bit	Name	Function
7:6	Reserved	Reserved.
5	CMD_INT	Command Interrupt Status.
4	PS3_INT	PS3 Interrupt Status.
3	PS2_INT	PS3 Interrupt Status.
2	PS1_INT	PS1 Interrupt Status.
1:0	ALS_INT	ALS Interrupt Status. (Refer to Table 13 for encoding.)

Notes:

1. If the corresponding IRQ_ENABLE bit is also set when the IRQ_STATUS bit is set, the INT pin is asserted.
2. When INT_MODE = 0, the host must write '1' to the corresponding XXX_INT bit to clear the interrupt.
3. When INT_MODE = 1, the internal sequencer clears all the XXX_INT bits (and INT pin) automatically unless used with PS (Parameter Field PSx_IM = 11). Use of INT_MODE = 0 is recommended.

ALS_VIS_DATA0: ALS_VIS_DATA Data Word Low Byte @ 0x22

Bit	7	6	5	4	3	2	1	0
Name	ALS_VIS_DATA[7:0]							
Type	RW							

Reset value = 0000 0000

Bit	Name	Function
7:0	ALS_VIS_DATA[7:0]	ALS VIS Data LSB. Once autonomous measurements have started, this register must be read after INT has asserted but before the next measurement is made. Refer to "AN498: Si114x Designer's Guide" Section 5.6.2 "Host Interrupt Latency."

ALS_VIS_DATA1: ALS_VIS_DATA Data Word High Byte @ 0x23

Bit	7	6	5	4	3	2	1	0
Name	ALS_VIS_DATA[15:8]							
Type	RW							

Reset value = 0000 0000

Bit	Name	Function
7:0	ALS_VIS_DATA[15:8]	ALS VIS Data MSB. Once autonomous measurements have started, this register must be read after INT has asserted but before the next measurement is made. Refer to "AN498: Si114x Designer's Guide" Section 5.6.2 "Host Interrupt Latency."

ALS_IR_DATA0: ALS_IR_DATA Data Word Low Byte@ 0x24

Bit	7	6	5	4	3	2	1	0
Name	ALS_IR_DATA[7:0]							
Type	RW							

Reset value = 0000 0000

Bit	Name	Function
7:0	ALS_IR_DATA[7:0]	ALS IR Data LSB. Once autonomous measurements have started, this register must be read after INT has asserted but before the next measurement is made. Refer to "AN498: Si114x Designer's Guide" Section 5.6.2 "Host Interrupt Latency."

ALS_IR_DATA1: ALS_IR_DATA Data Word High Byte @ 0x25

Bit	7	6	5	4	3	2	1	0
Name	ALS_IR_DATA[15:8]							
Type	RW							

Reset value = 0000 0000

Bit	Name	Function
7:0	ALS_IR_DATA[15:8]	ALS IR Data MSB. Once autonomous measurements have started, this register must be read after INT has asserted but before the next measurement is made. Refer to "AN498: Si114x Designer's Guide" Section 5.6.2 "Host Interrupt Latency."

PS1_DATA0: PS1_DATA Data Word Low Byte @ 0x26

Bit	7	6	5	4	3	2	1	0
Name	PS1_DATA[7:0]							
Type	RW							

Reset value = 0000 0000

Bit	Name	Function
7:0	PS1_DATA[7:0]	PS1 Data LSB. Once autonomous measurements have started, this register must be read after INT has asserted but before the next measurement is made. Refer to "AN498: Si114x Designer's Guide" Section 5.6.2 "Host Interrupt Latency."

Si1141/42/43

PS1_DATA1: PS1_DATA Data Word High Byte @ 0x27

Bit	7	6	5	4	3	2	1	0
Name	PS1_DATA[15:8]							
Type	RW							

Reset value = 0000 0000

Bit	Name	Function
7:0	PS1_DATA[15:8]	PS1 Data MSB. Once autonomous measurements have started, this register must be read after INT has asserted but before the next measurement is made. Refer to "AN498: Si114x Designer's Guide" Section 5.6.2 "Host Interrupt Latency."

PS2_DATA0: PS2_DATA Data Word Low Byte @ 0x28

Bit	7	6	5	4	3	2	1	0
Name	PS2_DATA[7:0]							
Type	RW							

Reset value = 0000 0000

Bit	Name	Function
7:0	PS2_DATA[7:0]	PS2 Data LSB. Once autonomous measurements have started, this register must be read after INT has asserted but before the next measurement is made. Refer to "AN498: Si114x Designer's Guide" Section 5.6.2 "Host Interrupt Latency."

PS2_DATA1: PS2_DATA Data Word High Byte @ 0x29

Bit	7	6	5	4	3	2	1	0
Name	PS2_DATA[15:8]							
Type	RW							

Reset value = 0000 0000

Bit	Name	Function
7:0	PS2_DATA[15:8]	PS2 Data MSB. Once autonomous measurements have started, this register must be read after INT has asserted but before the next measurement is made. Refer to "AN498: Si114x Designer's Guide" Section 5.6.2 "Host Interrupt Latency."

PS3_DATA0: PS3_DATA Data Word Low Byte @ 0x2A

Bit	7	6	5	4	3	2	1	0
Name	PS3_DATA[7:0]							
Type	RW							

Reset value = 0000 0000

Bit	Name	Function
7:0	PS3_DATA[7:0]	PS3 Data LSB. Once autonomous measurements have started, this register must be read after INT has asserted but before the next measurement is made. Refer to "AN498: Si114x Designer's Guide" Section 5.6.2 "Host Interrupt Latency."

PS3_DATA1: PS3_DATA Data Word High Byte @ 0x2B

Bit	7	6	5	4	3	2	1	0
Name	PS3_DATA[15:8]							
Type	RW							

Reset value = 0000 0000

Bit	Name	Function
7:0	PS3_DATA[15:8]	PS3 Data MSB. Once autonomous measurements have started, this register must be read after INT has asserted but before the next measurement is made. Refer to "AN498: Si114x Designer's Guide" Section 5.6.2 "Host Interrupt Latency."

AUX_DATA0: AUX_DATA Data Word Low Byte @ 0x2C

Bit	7	6	5	4	3	2	1	0
Name	AUX_DATA[7:0]							
Type	RW							

Reset value = 0000 0000

Bit	Name	Function
7:0	AUX_DATA[7:0]	AUX Data LSB. Once autonomous measurements have started, this register must be read after INT has asserted but before the next measurement is made. Refer to "AN498: Si114x Designer's Guide" Section 5.6.2 "Host Interrupt Latency."

Si1141/42/43

AUX_DATA1: AUX_DATA Data Word High Byte @ 0x2D

Bit	7	6	5	4	3	2	1	0
Name	AUX_DATA[15:8]							
Type	RW							

Reset value = 0000 0000

Bit	Name	Function
7:0	AUX_DATA[15:8]	AUX Data MSB. Once autonomous measurements have started, this register must be read after INT has asserted but before the next measurement is made. Refer to "AN498: Si114x Designer's Guide" Section 5.6.2 "Host Interrupt Latency."

PARAM_RD @ 0x2E

Bit	7	6	5	4	3	2	1	0
Name	PARAM_RD							
Type	RW							

Reset value = 0000 0000

Bit	Name	Function
7:0	PARAM_RD	Mailbox register for passing parameters from the sequencer to the host.

CHIP_STAT @ 0x30

Bit	7	6	5	4	3	2	1	0
Name						RUNNING	SUSPEND	SLEEP
Type						R	R	R

Reset value = 0000 0000

Bit	Name	Function
7:3	Reserved	Reserved
2	RUNNING	Device is awake.
1	SUSPEND	Device is in a low-power state, waiting for a measurement to complete.
0	SLEEP	Device is in its lowest power state.

ANA_IN_KEY @ 0x3B to 0x3E

Bit	7	6	5	4	3	2	1	0
0x3B	ANA_IN_KEY[31:24]							
0x3C	ANA_IN_KEY[23:16]							
0x3D	ANA_IN_KEY[15:8]							
0x3E	ANA_IN_KEY[7:0]							
Type	RW							

Reset value = 0000 0000

Bit	Name	Function
31:0	ANA_IN_KEY[31:0]	Reserved.

4.7. Parameter RAM

Parameters are located in internal memory and are not directly addressable over I²C. They must be indirectly accessed using the PARAM_QUERY and PARAM_SET Commands that are described in "4.2. Command Protocol" on page 21.

Table 16. Parameter RAM Summary Table

Parameter Name	Offset	Bit 7	Bit 6	Bit 5	Bit 4	Bit 3	Bit 2	Bit 1	Bit 0	
I2C_ADDR	0x00	I ² C Address								
CHLIST	0x01	—	EN_AUX	EN_ALS_IR	EN_ALS_VIS	—	EN_PS3	EN_PS2	EN_PS1	
PSLED12_SELECT	0x02	—	PS2_LED			—	PS1_LED			
PSLED3_SELECT	0x03	—					PS3_LED			
Reserved	0x04	Reserved (always set to 0)								
PS_ENCODING	0x05	—	PS3_ALIGN	PS2_ALIGN	PS1_ALIGN	Reserved (always set to 0)				
ALS_ENCODING	0x06	—	—	ALS_IR_ALIGN	ALS_VIS_ALIGN	Reserved (always set to 0)				
PS1_ADCMUX	0x07	PS1 ADC Input Selection								
PS2_ADCMUX	0x08	PS2 ADC Input Selection								
PS3_ADCMUX	0x09	PS3 ADC Input Selection								
PS_ADC_COUNTER	0x0A	—	PS_ADC_REC			Reserved (always set to 0)				
PS_ADC_GAIN	0x0B	—					PS_ADC_GAIN			
PS_ADC_MISC	0x0C	—	—	PS_RANGE	—	—	PS_ADC_MODE	—	—	
Reserved	0x0D	Reserved (do not modify from default setting of 0x02)								
ALS_IR_ADCMUX	0x0E	ALS_IR_ADCMUX								
AUX_ADCMUX	0x0F	AUX ADC Input Selection								
ALS_VIS_ADC_COUNTER	0x10	—	VIS_ADC_REC			Reserved (always set to 0)				
ALS_VIS_ADC_GAIN	0x11	—					ALS_VIS_ADC_GAIN			
ALS_VIS_ADC_MISC	0x12	Reserved (always set to 0)		VIS_RANGE	Reserved (always set to 0)					
Reserved	0x13	Reserved (do not modify from default setting of 0x40)								
Reserved	0x14–0x15	Reserved (do not modify from default setting of 0x00)								
ALS_HYST	0x16	ALS Hysteresis								
PS_HYST	0x17	PS Hysteresis								
PS_HISTORY	0x18	PS History Setting								

Table 16. Parameter RAM Summary Table (Continued)

Parameter Name	Offset	Bit 7	Bit 6	Bit 5	Bit 4	Bit 3	Bit 2	Bit 1	Bit 0	
ALS_HISTORY	0x19	ALS History Setting								
ADC_OFFSET	0x1A	ADC Offset								
Reserved	0x1B	Reserved (do not modify from default setting of 0x00)								
LED_REC	0x1C	LED recovery time								
ALS_IR_ADC_COUNTER	0x1D	—	IR_ADC_REC			Reserved (always set to 0)				
ALS_IR_ADC_GAIN	0x1E	—					ALS_IR_ADC_GAIN			
ALS_IR_ADC_MISC	0x1F	Reserved (always set to 0)		IR_RANGE	Reserved (always set to 0)					

I2C @ 0x00

Bit	7	6	5	4	3	2	1	0
Name	I ² C Address[7:0]							
Type	RW							

Reset value = 0000 0000

Bit	Name	Function
7:0	I ² C Address[7:0]	Specifies a new I ² C Address for the device to respond to. The new address takes effect when a BUSADDR command is received.

CHLIST @ 0x01

Bit	7	6	5	4	3	2	1	0
Name		EN_AUX	EN_ALS_IR	EN_ALS_VIS		EN_PS3	EN_PS2	EN_PS1
Type	RW					RW		

Reset value = 0000 0000

Bit	Name	Function
7	Reserved	
6	EN_AUX	Enables Auxiliary Channel, data stored in AUX_DATA1[7:0] and AUX_DATA0[7:0].
5	EN_ALS_IR	Enables ALS IR Channel, data stored in ALS_IR_DATA1[7:0] and ALS_IR_DATA0[7:0].
4	EN_ALS_VIS	Enables ALS Visible Channel, data stored in ALS_VIS_DATA1[7:0] and ALS_VIS_DATA0[7:0].

Si1141/42/43

Bit	Name	Function
3	Reserved	
2	EN_PS3	Enables PS Channel 3, data stored in PS3_DATA1[7:0] and PS3_DATA0[7:0].
1	EN_PS2	Enables PS Channel 2, data stored in PS2_DATA1[7:0] and PS2_DATA0[7:0].
0	EN_PS1	Enables PS Channel 1, data stored in PS1_DATA1[7:0] and PS1_DATA0[7:0].

Note: For proper operation, CHLIST must be written with a non-zero value before forced measurements or autonomous operation is requested.

PSLED12_SELECT @ 0x02

Bit	7	6	5	4	3	2	1	0
Name		PS2_LED[2:0]				PS1_LED[2:0]		
Type		RW				RW		

Reset value = 0010 0001

Bit	Name	Function
7	Reserved	
6:4	PS2_LED[2:0]	Specifies the LED pin driven during the PS2 Measurement. Note that any combination of irLEDs is possible. 000: NO LED DRIVE xx1: LED1 Drive Enabled x1x: LED2 Drive Enabled (Si1142 and Si1143 only. Clear for Si1141) 1xx: LED3 Drive Enabled (Si1143 only. Clear for Si1141 and Si1142)
3	Reserved	
2:0	PS1_LED[2:0]	Specifies the LED pin driven during the PS1 Measurement. Note that any combination of irLEDs is possible. 000: NO LED DRIVE xx1: LED1 Drive Enabled x1x: LED2 Drive Enabled (Si1142 and Si1143 only. Clear for Si1141) 1xx: LED3 Drive Enabled (Si1143 only. Clear for Si1141 and Si1142)

PSLED3_SELECT @ 0x03

Bit	7	6	5	4	3	2	1	0
Name						PS3_LED[2:0]		
Type						RW		

Reset value = 0000 0100

Bit	Name	Function
7:3	Reserved	
2:0	PS3_LED[2:0]	Specifies the LED pin driven during the PS3 Measurement. Note that any combination of irLEDs is possible. 000: No LED drive. xx1: LED1 drive enabled. x1x: LED2 drive enabled (Si1142 and Si1143 only. Clear for Si1141). 1xx: LED3 drive enabled (Si1143 only. Clear for Si1141 and Si1142).

PS_ENCODING @ 0x05

Bit	7	6	5	4	3	2	1	0
Name		PS3_ALIGN	PS2_ALIGN	PS1_ALIGN				
Type		RW	R/W	R/W				

Reset value = 0000 0000

Bit	Name	Function
7	Reserved	
6	PS3_ALIGN	When set, the ADC reports the least significant 16 bits of the 17-bit ADC when performing PS3 Measurement. Reports the 16 MSBs when cleared.
5	PS2_ALIGN	When set, the ADC reports the least significant 16 bits of the 17-bit ADC when performing PS2 Measurement. Reports the 16 MSBs when cleared.
4	PS1_ALIGN	When set, the ADC reports the least significant 16 bits of the 17-bit ADC when performing PS1 Measurement. Reports the 16 MSBs when cleared.
3:0	Reserved	Always set to 0.

ALS_ENCODING @ 0x06

Bit	7	6	5	4	3	2	1	0
Name			ALS_IR_ALIGN	ALS_VIS_ALIGN				
Type			RW	RW				

Reset value = 0000 0000

Bit	Name	Function
7:6	Reserved	
5	ALS_IR_ALIGN	When set, the ADC reports the least significant 16 bits of the 17-bit ADC when performing ALS VIS Measurement. Reports the 16 MSBs when cleared.

Si1141/42/43

Bit	Name	Function
4	ALS_VIS_ALIGN	When set, the ADC reports the least significant 16 bits of the 17-bit ADC when performing ALS IR Measurement. Reports the 16 MSBs when cleared.
3:0	Reserved	Always set to 0.

PS1_ADCMUX @ 0x07

Bit	7	6	5	4	3	2	1	0
Name	PS1_ADCMUX[7:0]							
Type	RW							

Reset value = 0000 0011

Bit	Name	Function
7:0	PS1_ADCMUX[7:0]	<p>Selects ADC Input for PS1 Measurement.</p> <p>The following selections are valid when PS_ADC_MODE = 1 (default). This setting is for normal Proximity Detection function.</p> <p>0x03: Large IR Photodiode 0x00: Small IR Photodiode</p> <p>In addition, the following selections are valid for PS_ADC_MODE = 0. With this setting, irLED drives are disabled and the PS channels are no longer operating in normal Proximity Detection function. The results have no reference and the references needs to be measured in a separate measurement.</p> <p>0x02: Visible Photodiode</p> <p>A separate 'No Photodiode' measurement should be subtracted from this reading. Note that the result is a negative value. The result should therefore be negated to arrive at the Ambient Visible Light reading.</p> <p>0x03: Large IR Photodiode A separate "No Photodiode" measurement should be subtracted to arrive at Ambient IR reading.</p> <p>0x00: Small IR Photodiode A separate "No Photodiode" measurement should be subtracted to arrive at Ambient IR reading.</p> <p>0x06: No Photodiode This is typically used as reference for reading ambient IR or visible light.</p> <p>0x25: GND voltage This is typically used as the reference for electrical measurements.</p> <p>0x65: Temperature (Should be used only for relative temperature measurement. Absolute Temperature not guaranteed) A separate GND measurement should be subtracted from this reading.</p> <p>0x75: V_{DD} voltage A separate GND measurement is needed to make the measurement meaningful.</p>

PS2_ADCMUX @ 0x08

Bit	7	6	5	4	3	2	1	0
Name	PS2_ADCMUX[7:0]							
Type	R/W							

Reset value = 0000 0011

Bit	Name	Function
7:0	PS2_ADCMUX[7:0]	Selects input for PS2 measurement. See PS1_ADCMUX register description for details.

PS3_ADCMUX @ 0x09

Bit	7	6	5	4	3	2	1	0
Name	PS3_ADCMUX[7:0]							
Type	R/W							

Reset value = 0000 0011

Bit	Name	Function
7:0	PS3_ADCMUX[7:0]	Selects input for PS3 measurement. See PS1_ADCMUX register description for details.

PS_ADC_COUNTER @ 0x0A

Bit	7	6	5	4	3	2	1	0
Name		PS_ADC_REC[2:0]						
Type		RW	R/W	R/W				

Reset value = 0111 0000

Bit	Name	Function
7	Reserved	
6:4	PS_ADC_REC[2:0]	Recovery period the ADC takes before making a PS measurement. 000: 1 ADC Clock (50 ns times $2^{PS_ADC_GAIN}$) 001: 7 ADC Clock (350 ns times $2^{PS_ADC_GAIN}$) 010: 15 ADC Clock (750 ns times $2^{PS_ADC_GAIN}$) 011: 31 ADC Clock (1.55 μ s times $2^{PS_ADC_GAIN}$) 100: 63 ADC Clock (3.15 μ s times $2^{PS_ADC_GAIN}$) 101: 127 ADC Clock (6.35 μ s times $2^{PS_ADC_GAIN}$) 110: 255 ADC Clock (12.75 μ s times $2^{PS_ADC_GAIN}$) 111: 511 ADC Clock (25.55 μ s times $2^{PS_ADC_GAIN}$) The recommended PS_ADC_REC value is the one's complement of PS_ADC_GAIN.
3:0	Reserved	Always set to 0.

PS_ADC_GAIN @ 0x0B

Bit	7	6	5	4	3	2	1	0
Name						PS_ADC_GAIN[2:0]		
Type						R/W	R/W	R/W

Reset value = 0000 0000

Bit	Name	Function
7:3	Reserved	
2:0	PS_ADC_GAIN[2:0]	Increases the irLED pulse width and ADC integration time by a factor of $(2 \wedge PS_ADC_GAIN)$ for all PS measurements. Care must be taken when using this feature. At an extreme case, each of the three PS measurements can be configured to drive three separate irLEDs, each of which, are configured for 359 mA. The internal sequencer does not protect the device from such an error. To prevent permanent damage to the device, do not enter any value greater than 5 without consulting with Silicon Labs. For Example: 0x0: ADC Clock is divided by 1 0x4: ADC Clock is divided by 16 0x5: ADC Clock is divided by 32

PS_ADC_MISC @ 0x0C

Bit	7	6	5	4	3	2	1	0
Name			PS_RANGE			PS_ADC_MODE		
Type	RW				RW			

Reset value = 0000 0100

Bit	Name	Function
7:6	Reserved	
5	PS_RANGE	When performing PS measurements, the ADC can be programmed to operate in high sensitivity operation or high signal range. The high signal range is useful in operation under direct sunlight. 0: Normal Signal Range 1: High Signal Range (Gain divided by 14.5)
4:3	Reserved	
2	PS_ADC_MODE	PS Channels can either operate normally as PS channels, or it can be used to perform raw ADC measurements: 0: Raw ADC Measurement Mode 1: Normal Proximity Measurement Mode
1:0	Reserved	

ALS_IR_ADCMUX @ 0x0E

Bit	7	6	5	4	3	2	1	0
Name	ALS_IR_ADCMUX							
Type	RW							

Reset value = 0000 0000

Bit	Name	Function
7:0	ALS_IR_ADCMUX	Selects ADC Input for ALS_IR Measurement. 0x00: Small IR photodiode 0x03: Large IR photodiode

Si1141/42/43

AUX_ADCMUX @ 0x0F

Bit	7	6	5	4	3	2	1	0
Name	AUX_ADCMUX[7:0]							
Type	RW							

Reset value = 0110 0101

Bit	Name	Function
7:0	AUX_ADCMUX[7:0]	Selects input for AUX Measurement. These measurements are referenced to GND. 0x65: Temperature (Should be used only for relative temperature measurement. Absolute Temperature not guaranteed) 0x75: V _{DD} voltage

ALS_VIS_ADC_COUNTER @ 0x10

Bit	7	6	5	4	3	2	1	0
Name	VIS_ADC_REC[2:0]							
Type	RW		R/W	R/W				

Reset value = 0111 0000

Bit	Name	Function
7	Reserved	
6:4	VIS_ADC_REC[2:0]	Recovery period the ADC takes before making a ALS-VIS measurement. 000: 1 ADC Clock (50 ns times 2 ^{ALS_VIS_ADC_GAIN}) 001: 7 ADC Clock (350 ns times 2 ^{ALS_VIS_ADC_GAIN}) 010: 15 ADC Clock (750 ns times 2 ^{ALS_VIS_ADC_GAIN}) 011: 31 ADC Clock (1.55 μs times 2 ^{ALS_VIS_ADC_GAIN}) 100: 63 ADC Clock (3.15 μs times 2 ^{ALS_VIS_ADC_GAIN}) 101: 127 ADC Clock (6.35 μs times 2 ^{ALS_VIS_ADC_GAIN}) 110: 255 ADC Clock (12.75 μs times 2 ^{ALS_VIS_ADC_GAIN}) 111: 511 ADC Clock (25.55 μs times 2 ^{ALS_VIS_ADC_GAIN}) The recommended VIS_ADC_REC value is the one's complement of ALS_VIS_ADC_GAIN.
3:0	Reserved	Always set to 0.

Note: For A02 and earlier, this parameter also controls ALS-IR measurements.

ALS_VIS_ADC_GAIN @ 0x11

Bit	7	6	5	4	3	2	1	0
Name						ALS_VIS_ADC_GAIN[2:0]		
Type						RW	R/W	RW

Reset value = 0000 0000

Bit	Name	Function
7:3	Reserved	
2:0	ALS_VIS_ADC_GAIN[2:0]	Increases the ADC integration time for ALS Visible measurements by a factor of $(2^{\text{ALS_VIS_ADC_GAIN}})$. This allows visible light measurement under dark glass. The maximum gain is 128 (0x7). For Example: 0x0: ADC Clock is divided by 1 0x4: ADC Clock is divided by 16 0x6: ADC Clock is divided by 64
Note: For A02 and earlier, this parameter also controls ALS-IR measurements.		

ALS_VIS_ADC_MISC @ 0x12

Bit	7	6	5	4	3	2	1	0
Name			VIS_RANGE					
Type			RW					

Reset value = 0000 0000

Bit	Name	Function
7:6	Reserved	
5	VIS_RANGE	When performing ALS-VIS measurements, the ADC can be programmed to operate in high sensitivity operation or high signal range. The high signal range is useful in operation under direct sunlight. 0: Normal Signal Range 1: High Signal Range (Gain divided by 14.5)
4:0	Reserved	
Note: For A02 and earlier, this parameter also controls ALS-IR measurements.		

Si1141/42/43

ALS_HYST @ 0x16

Bit	7	6	5	4	3	2	1	0
Name	ALS_HYST[7:0]							
Type	RW							

Reset value = 0100 1000

Bit	Name	Function
7:0	ALS_HYST[7:0]	ALS_HYST represents a hysteresis applied to the ALS_LOW_TH and ALS_HIGH_TH thresholds. This is in an 8-bit compressed format, representing a 16-bit value. For example: 0x48: 24 ADC Codes Please refer to “AN498: Si114x Designer's Guide”, Section 5.4 “Compression Concept.”

PS_HYST @ 0x17

Bit	7	6	5	4	3	2	1	0
Name	PS_HYST[7:0]							
Type	RW							

Reset value = 0100 1000

Bit	Name	Function
7:0	PS_HYST[7:0]	PS_HYST represents a hysteresis applied to the PS1_TH, PS2_TH and PS3_TH thresholds. This is in an 8-bit compressed format, representing a 16-bit value. For example: 0x48: 24 ADC Codes. Please refer to “AN498: Si114x Designer's Guide”, Section 5.4 “Compression Concept.”

PS_HISTORY @ 0x18

Bit	7	6	5	4	3	2	1	0
Name	PS_HISTORY[7:0]							
Type	RW							

Reset value = 0000 0011

Bit	Name	Function
7:0	PS_HISTORY[7:0]	PS_HISTORY is a bit-field representing the number of consecutive samples exceeding the threshold and hysteresis to change status. For example: 0x03: 2 consecutive samples 0x07: 3 consecutive samples 0xFF: 8 consecutive samples

ALS_HISTORY @ 0x19

Bit	7	6	5	4	3	2	1	0
Name	ALS_HISTORY[7:0]							
Type	RW							

Reset value = 0000 0011

Bit	Name	Function
7:0	ALS_HISTORY[7:0]	ALS_HISTORY is a bit-field representing the number of consecutive samples exceeding the threshold and hysteresis to change status. For example: 0x03: Two consecutive samples 0x07: Three consecutive samples 0xFF: Eight consecutive samples

ADC_OFFSET @ 0x1A

Bit	7	6	5	4	3	2	1	0
Name	ADC_OFFSET[7:0]							
Type	RW							

Reset value = 1000 0000

Si1141/42/43

Bit	Name	Function
7:0	ADC_OFFSET[7:0]	<p>ADC_OFFSET is an 8-bit compressed value representing a 16-bit value added to all measurements. Since most measurements are relative measurements involving an arithmetic subtraction and can result in a negative value. Since 0xFFFF is treated as an overrange indicator, the ADC_OFFSET is added so that the values reported in the I²C register map are never confused with the 0xFFFF overrange indicator.</p> <p>For example: 0x60: Measurements have a 64-code offset 0x70: Measurements have a 128-code offset 0x80: Measurements have a 256-code offset</p> <p>Please refer to “AN498: Si114x Designer's Guide”, Section 5.4 “Compression Concept.”</p>

LED_REC @ 0x1C

Bit	7	6	5	4	3	2	1	0
Name	LED_REC[7:0]							
Type	RW							

Reset value = 0000 0000

Bit	Name	Function
7:0	LED_REC[7:0]	Reserved.

ALS_IR_ADC_COUNTER @ 0x1D

Bit	7	6	5	4	3	2	1	0
Name	IR_ADC_REC[2:0]							
Type	RW							

Reset value = 0111 0000

Bit	Name	Function
7	Reserved	
6:4	IR_ADC_REC[2:0]	Recovery period the ADC takes before making a ALS-IR measurement. 000: 1 ADC Clock (50 ns times $2^{\text{ALS_IR_ADC_GAIN}}$) 001: 7 ADC Clock (350 ns times $2^{\text{ALS_IR_ADC_GAIN}}$) 010: 15 ADC Clock (750 ns times $2^{\text{ALS_IR_ADC_GAIN}}$) 011: 31 ADC Clock (1.55 μ s times $2^{\text{ALS_IR_ADC_GAIN}}$) 100: 63 ADC Clock (3.15 μ s times $2^{\text{ALS_IR_ADC_GAIN}}$) 101: 127 ADC Clock (6.35 μ s times $2^{\text{ALS_IR_ADC_GAIN}}$) 110: 255 ADC Clock (12.75 μ s times $2^{\text{ALS_IR_ADC_GAIN}}$) 111: 511 ADC Clock (25.55 μ s times $2^{\text{ALS_IR_ADC_GAIN}}$) The recommended IR_ADC_REC value is the one's complement of ALS_IR_ADC_GAIN.
3:0	Reserved	Always set to 0.

Note: This parameter available for sequencer revisions A03 or later.

ALS_IR_ADC_GAIN @ 0x1E

Bit	7	6	5	4	3	2	1	0
Name						ALS_IR_ADC_GAIN[2:0]		
Type						R/W	R/W	R/W

Reset value = 0000 0000

Bit	Name	Function
7:3	Reserved	
2:0	ALS_IR_ADC_GAIN[2:0]	Increases the ADC integration time for IR Ambient measurements by a factor of $(2^{\text{ALS_IR_ADC_GAIN}})$. The maximum gain is 128 (0x7). For Example: 0x0: ADC Clock is divided by 1 0x4: ADC Clock is divided by 16 0x6: ADC Clock is divided by 64

Note: This parameter available for sequencer revisions A03 or later.

ALS_IR_ADC_MISC @ 0x1F

Bit	7	6	5	4	3	2	1	0
Name			IR_RANGE					
Type			RW					

Reset value = 0000 0000

Bit	Name	Function
7:6	Reserved	
5	IR_RANGE	When performing ALS-IR measurements, the ADC can be programmed to operate in high sensitivity operation or high signal range. The high signal range is useful in operation under direct sunlight. 0: Normal Signal Range 1: High Signal Range (Gain divided by 14.5)
4:0	Reserved	Write operations to this RAM parameter must preserve this bit-field value using read-modify-write.
Note: This parameter is available for sequencer revisions A03 or later.		

Not Recommended for New Designs

5. Pin Descriptions

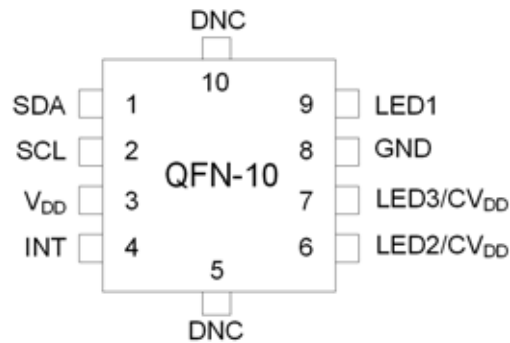

Table 17. Pin Descriptions

Pin	Name	Type	Description
1	SDA	Bidirectional	I ² C Data.
2	SCL	Input	I ² C Clock.
3	V _{DD}	Power	Power Supply. Voltage source.
4	INT	Bidirectional	Interrupt Output. Open-drain interrupt output pin. Must be at logic level high during power-up sequence to enable low power operation.
5	DNC		Do Not Connect. This pin is electrically connected to an internal Si1141/42/43 node. It should remain unconnected.
6	LED2/CV _{DD} ¹	Output	LED2 Output/Connect to V _{DD} . ¹ Programmable constant current sink normally connected to an infrared LED cathode. Connect directly to V _{DD} when not in use.
7	LED3/CV _{DD} ²	Output	LED3 Output./Connect to V _{DD} . ² Programmable constant current sink normally connected to an infrared LED cathode. If V _{LED} < (V _{DD} + 0.5 V), a 47 kΩ pull-up resistor from LED3 to V _{DD} is needed for proper operation. Connect directly to V _{DD} when not in use.
8	GND	Power	Ground. Reference voltage.
9	LED1	Output	LED1 Output. Programmable constant current sink normally connected to an infrared LED cathode.
10	DNC		Do Not Connect. This pin is electrically connected to an internal Si1141/42/43 node. It should remain unconnected.

Notes:

1. Si1142 and Si1143 only. Must connect to V_{DD} in Si1141.
2. Si1143 only. Must connect to V_{DD} in Si1141 and Si1142.

6. Ordering Guide

Part Number	Package	LED Drivers	AEC-Q100
Si1141-A11-GMR ¹	QFN-10	1	N
Si1142-A11-GMR ²	QFN-10	2	N
Si1143-A11-GMR ¹	QFN-10	3	N
Si1141-A11-YM0R ²	QFN-10	1	Y
Si1143-A11-YM0R ²	QFN-10	3	Y

Notes:

1. Not Recommended for New Designs.
2. End of life.

7. Package Outline: 10-Pin QFN

Figure 15 illustrates the package details for the Si1141/42/43 QFN package. Table 18 lists the values for the dimensions shown in the illustration.

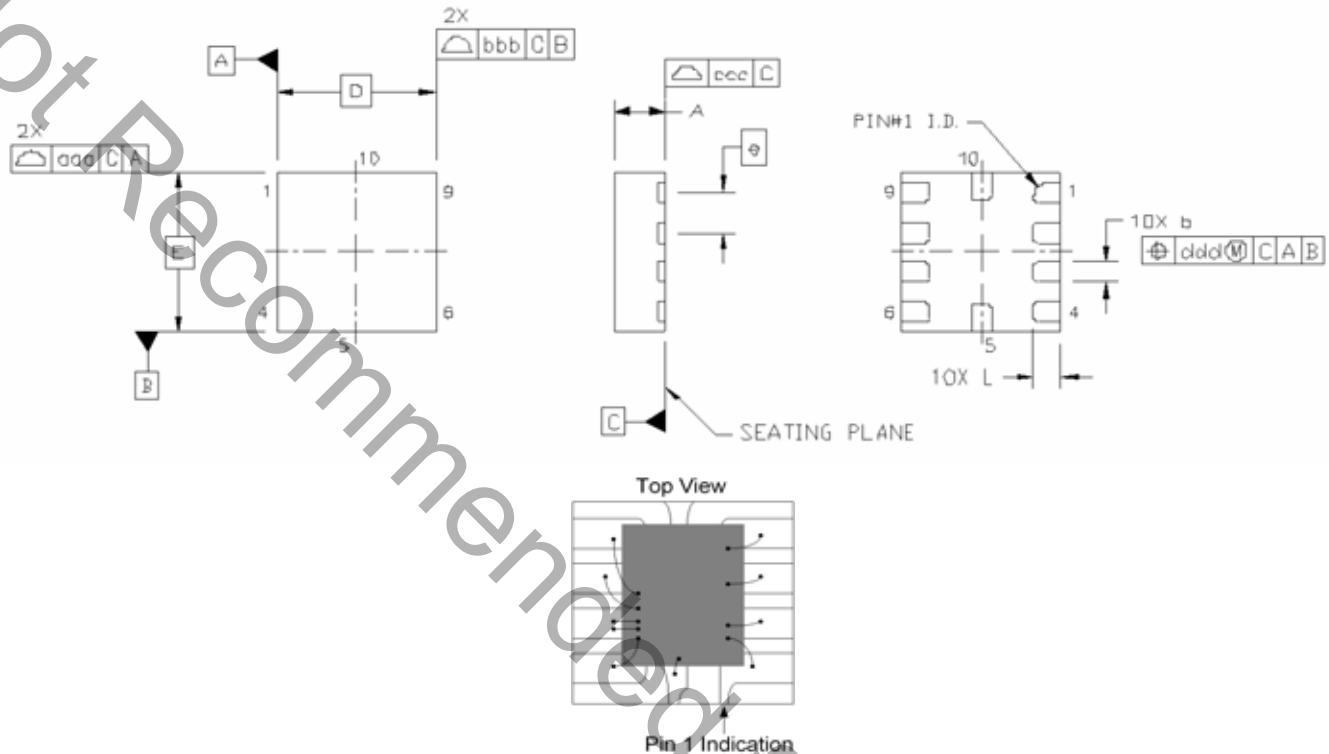

Figure 15. QFN Package Diagram Dimensions

Table 18. Package Diagram Dimensions

Dimension	Min	Nom	Max
A	0.55	0.65	0.75
b	0.20	0.25	0.30
D	2.00 BSC.		
e	0.50 BSC.		
E	2.00 BSC.		
L	0.30	0.35	0.40
aaa	0.10		
bbb	0.10		
ccc	0.08		
ddd	0.10		
Notes:			
1. All dimensions shown are in millimeters (mm).			
2. Dimensioning and Tolerancing per ANSI Y14.5M-1994.			

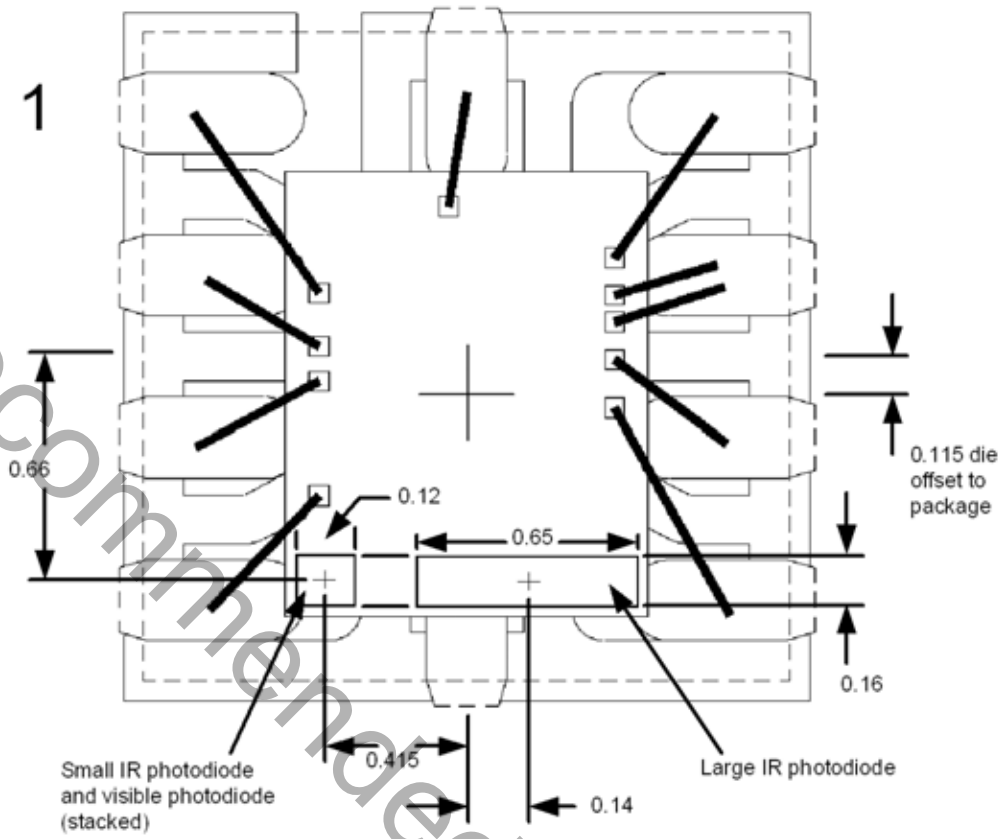
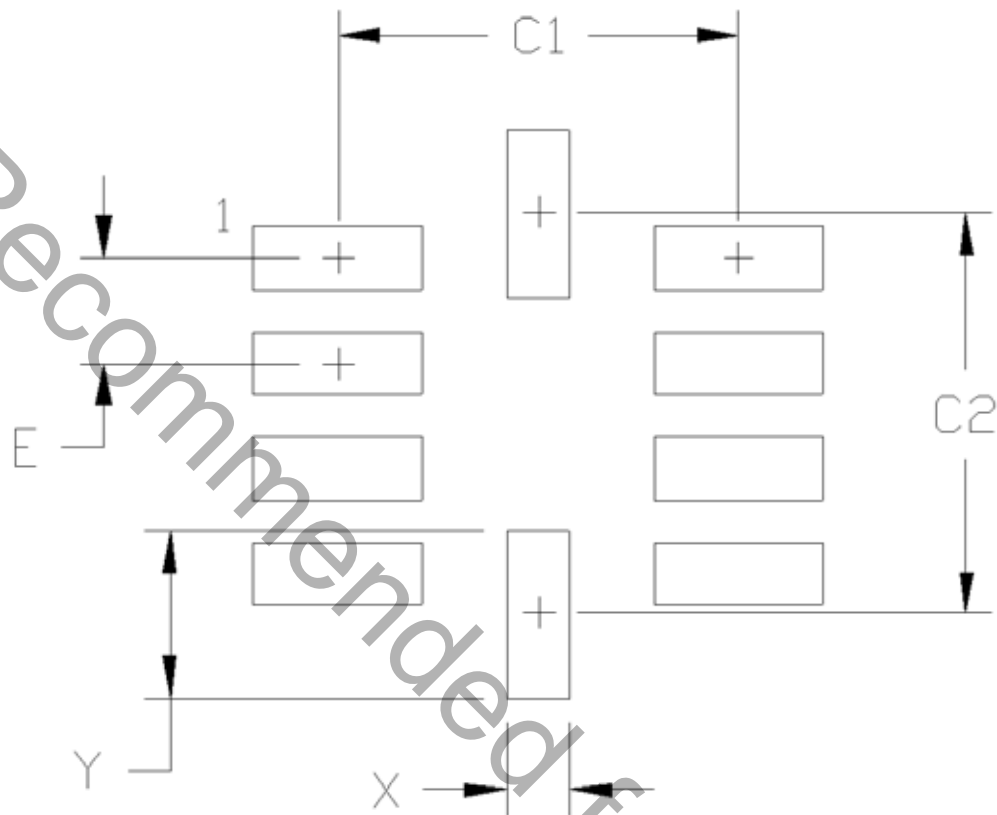

Figure 16. Photodiode Centers

8. Suggested PCB Land Pattern



Dimension	mm
C1	1.90
C2	1.90
E	0.50
X	0.30
Y	0.80

Notes:

General

1. All dimensions shown are in millimeters (mm).
2. This Land Pattern Design is based on the IPC-7351 guidelines.
3. All dimensions shown are at Maximum Material Condition (MMC). Least Material Condition (LMC) is calculated based on a Fabrication Allowance of 0.05 mm.

Solder Mask Design

4. All metal pads are to be non-solder mask defined (NSMD). Clearance between the solder mask and the metal pad is to be 0.060 mm minimum, all the way around the pad.

Stencil Design

5. A stainless steel, laser-cut and electro-polished stencil with trapezoidal walls should be used to assure good solder paste release.
6. The stencil thickness should be 0.125 mm (5 mils).
7. The ratio of stencil aperture to land pad size should be 1:1 for all pads.

Card Assembly

8. A No-Clean, Type-3 solder paste is recommended.
9. The recommended card reflow profile is per the JEDEC/IPC J-STD-020D specification for Small Body Components.

DOCUMENT CHANGE LIST

Revision 0.2 to Revision 0.3

- Updated document title from Si1140 to Si114x.
- Updated "7. Package Outline: 10-Pin QFN" on page 71.
- Updated Tables 4, 1, and 2.
- Added Figures 1, 2, and 4.
- Added register map and descriptions.

Revision 0.3 to Revision 0.4

- Updated document title from Si114x to Si1143.
- Updated Applications Section
- Updated Tables 2 and 3.
- Updated Figure 1, Figure 4.
- Updated Table 8, Table 9.
- Updated Pin Assignments.
- Updated Register maps and description.

Revision 0.4 to Revision 0.41

- Added Si1141 and Si1142 in addition to Si1143.
- Added the ODFN-8 package option.
- Some sections were rearranged.
- Added the signal-path software-model schematic.
- Renamed PARAM_IN to PARAM_WR for clarity.
- Renamed PARAM_OUT to PARAM_RD for clarity.
- Renamed PS_ADC_CLKDIV to PS_ADC_GAIN for clarity.
- Renamed ALS_VIS_ADC_CLKDIV to ALS_VIS_ADC_GAIN for clarity.
- Renamed ALS_IR_ADC_CLKDIV to ALS_IR_ADC_GAIN for clarity.
- Minor changes in register and parameter terminology.

Revision 0.41 to Revision 0.5

- Updated Tables 1, 4, 2, and 15.
- Updated Figure 1.
- Added Figures 2 and 16.
- Updated register table reset values.
- Added "HW_KEY @ 0x07" register.
- Updated "ALS_VIS_ADC_MISC @ 0x12" register.
- Updated "ALS_IR_ADC_MISC @ 0x1F" register.
- Updated "6. Ordering Guide" .
- Updated "Features" .
- Updated "Description" .
- Updated "5. Pin Descriptions" .
- Updated "6. Ordering Guide" .

- Updated "7. Package Outline: 10-Pin QFN" .
- Deleted Section 7.1.
- Deleted Section 7.2.

Revision 0.5 to Revision 1.0

- Lux range and other minor changes on front page.
- Added sensitivity data for all three photodiodes.
- Added offset-drift data for all three photodiodes.
- Updated startup time to 25 ms.
- Minor bit-field definition corrections.
- Clarified ripple-voltage recommendation.
- Added MM and CDM ESD rating.
- Clarified standby-mode I_{dd}.
- Clarified LED output leakage current.
- Added limits to LED active currents.
- Ordering code update.

Revision 1.0 to Revision 1.1

- Corrected reset state of PS_ADC_COUNTER.
- Minor correction in signal-path programming model schematic.
- Corrected access mode of ALS_IR_ADCMUX from register space to parameter space.

Revision 1.1 to Revision 1.2

- Corrected reset state of PS_ADC_COUNTER.
- Added leakage specifications for pins INT, SCL, and SDA.
- Changed format of proximity-threshold registers from compressed to uncompressed.
- Changed firmware revision from A10 to A11.
- Added reference to AN498 for details on the compression scheme.
- Clarified recovery times specified in PS_ADC_REC, VIS_ADC_REC, and IR_ADC_REC.
- Suggested PCB Land Pattern.
- Changed photodiode coordinate origin to package center.
- Added temperature sensor information.
- Added remarks on the use of MEAS_RATE, ALS_RATE, and PS_RATE.
- Added remarks on I²C Broadcast Reset.
- Added performance graphs.
- Changed format of PS1TH, PS2TH, PS3TH, ALS_LO_TH, ALS_HIGH_TH from 8-bit compressed to 16-bit linear to allow finer threshold control.

Revision 1.2 to Revision 1.3

- Updated bit names for ALS_LOW_TH0 @ 0x0B, ALS_LOW_TH1@0x0C, ALS_HI_TH0@0x0D, and ALS_HI_TH1@0x0E.
- Changed IRQ_MODE1 to IRQ_MODE2 in Table 14.
- Changed pin name for pin 5 in pin diagrams on first page and start of section 5 from NC to DNC.
- Changed pin name and description for pin 5 in Table 17.
- Min V_{DD} changed from 1.8 V to 1.71 V.

Revision 1.3 to Revision 1.4

- Added minimum I²C clock frequency.
- Updated photodiode spectral response.
- Clarified usage of Command Register and Parameter RAM.
- Clarified LED2 and LED3 connection when using Si1141 and Si1142.

Revision 1.4 to Revision 1.41

- Revised document title from Si114x to Si1141-42-43.
- Updated "6. Ordering Guide" .
 - Added orderable part numbers with AEC-Q100 qualification.

Revision 1.41 to Revision 1.42

- Added a missing ACK time period in Figure 12, "Host Interface Burst Read,".
- The description of INT operation in the "2.4. Host Interface" section is corrected.
- An ALWAYS_ACTIVE mode is added and described in the "3. Operational Modes" section.
- The Limitation of MEAS_RATE and the formula to use is corrected.
- The limitations of command write timing are explained in a new subsection in "3. Operational Modes" .
- Table 5, "Command Register Summary," on page 21 in the "4.2. Command Protocol" section contained references to an incorrect table number, which have been corrected.
- Table 15, "I2C Register Summary," on page 30 in the "4.6. I2C Registers" section has the HW_KEY register corrected. The value takes up all eight bits at register address (0x07).
- A new section, "3.7. Avoiding an Unexpected Reset" , was added describing a reset that may happen if all the cautions in the other sections are not followed.
- Updated "6. Ordering Guide" on page 70.

Revision 1.42 to Revision 1.43

- Updated "6. Ordering Guide" on page 70.

Revision 1.43 to Revision 1.44

- Updated "6. Ordering Guide" on page 70 to note NRND and EOL OPNs.

Smart. Connected.
Energy-Friendly.

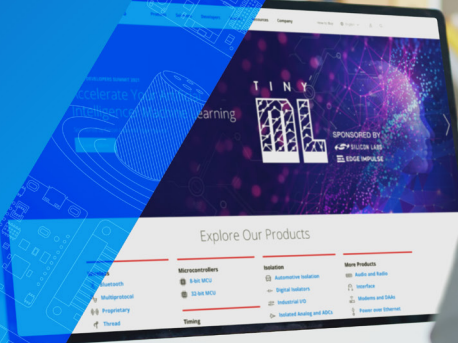

IoT Portfolio
www.silabs.com/products



Quality
www.silabs.com/quality



Support & Community
www.silabs.com/community

Disclaimer

Silicon Labs intends to provide customers with the latest, accurate, and in-depth documentation of all peripherals and modules available for system and software implementers using or intending to use the Silicon Labs products. Characterization data, available modules and peripherals, memory sizes and memory addresses refer to each specific device, and "Typical" parameters provided can and do vary in different applications. Application examples described herein are for illustrative purposes only. Silicon Labs reserves the right to make changes without further notice to the product information, specifications, and descriptions herein, and does not give warranties as to the accuracy or completeness of the included information. Without prior notification, Silicon Labs may update product firmware during the manufacturing process for security or reliability reasons. Such changes will not alter the specifications or the performance of the product. Silicon Labs shall have no liability for the consequences of use of the information supplied in this document. This document does not imply or expressly grant any license to design or fabricate any integrated circuits. The products are not designed or authorized to be used within any FDA Class III devices, applications for which FDA premarket approval is required or Life Support Systems without the specific written consent of Silicon Labs. A "Life Support System" is any product or system intended to support or sustain life and/or health, which, if it fails, can be reasonably expected to result in significant personal injury or death. Silicon Labs products are not designed or authorized for military applications. Silicon Labs products shall under no circumstances be used in weapons of mass destruction including (but not limited to) nuclear, biological or chemical weapons, or missiles capable of delivering such weapons. Silicon Labs disclaims all express and implied warranties and shall not be responsible or liable for any injuries or damages related to use of a Silicon Labs product in such unauthorized applications.

Note: This content may contain offensive terminology that is now obsolete. Silicon Labs is replacing these terms with inclusive language wherever possible. For more information, visit www.silabs.com/about-us/inclusive-lexicon-project

Trademark Information

Silicon Laboratories Inc., Silicon Laboratories®, Silicon Labs®, SiLabs® and the Silicon Labs logo®, Bluegiga®, Bluegiga Logo®, EFM®, EFM32®, EFR, Ember®, Energy Micro, Energy Micro logo and combinations thereof, "the world's most energy friendly microcontrollers", Redpine Signals®, WiSeConnect®, n-Link, ThreadArch®, EZLink®, EZRadio®, EZRadioPRO®, Gecko®, Gecko OS, Gecko OS Studio, Precision32®, Simplicity Studio®, Telegesis, the Telegesis Logo®, USBXpress®, Zentri, the Zentri logo and Zentri DMS, Z-Wave®, and others are trademarks or registered trademarks of Silicon Labs. ARM, CORTEX, Cortex-M3 and THUMB are trademarks or registered trademarks of ARM Holdings. Keil is a registered trademark of ARM Limited. Wi-Fi is a registered trademark of the Wi-Fi Alliance. All other products or brand names mentioned herein are trademarks of their respective holders.



Silicon Laboratories Inc.
400 West Cesar Chavez
Austin, TX 78701
USA

www.silabs.com

Looking for pricing, stock, or lifecycle information?

Click below to explore more details on WIN SOURCE:

 [View SI1141-A11-YM0 on WIN SOURCE](#)

 [Silicon Labs](#) Information

Optimize Your Supply Chain with WIN SOURCE Solutions

-  Global Sourcing Solution
-  Obsolete Management
-  Cost Control Management
-  Shortage Management
-  Alternative Solution
-  Excess Inventory Management