



**THE DATASHEET OF
SFH 3605-3-XX**



Silicon NPN Phototransistor in MIDLED package

Version 1.3

SFH 3605



Features:

- **Spectral range of sensitivity:** (typ) 500 ... 1100 nm
- **Package:** MIDLED, Silicone, colourless, clear
- **Special:** Sidelooker
- Narrow angle ($\pm 20^\circ$)
- Low profile component (1,6 mm)
- Emitter in same package (SFH 46xx) available
- The product qualification test plan is based on the guidelines of AEC-Q101-REV-C, Stress Test Qualification for Automotive Grade Discrete Semiconductors.

Applications

- Interrupters, light curtains
- Sensors (consumer and industrial applications)
- Automotive applications
- Proximity sensor

Ordering Information

Type:	Photocurrent I_{PCE} [μA] $\lambda = 950 \text{ nm}$, $E_e = 0.1 \text{ mW/cm}^2$, $V_{CE} = 5 \text{ V}$	Ordering Code
SFH 3605	100 ... 500	Q65110A1574
SFH 3605-2/3	100 ... 320	Q65110A2663
SFH 3605-3/4	160 ... 500	Q65110A2664

Note: Only one bin within one packing unit (variation less than 2:1)

Maximum Ratings ($T_A = 25\text{ °C}$)

Parameter	Symbol	Values	Unit
Operating and storage temperature range	$T_{op}; T_{stg}$	-40 ... 100	°C
Collector-emitter voltage	V_{CE}	35	V
Collector current	I_C	15	mA
Collector surge current ($\tau < 10\ \mu\text{s}$)	I_{CS}	75	mA
Emitter-collector voltage	V_{EC}	7	V
Total Power dissipation	P_{tot}	130	mW
ESD withstand voltage (acc. to ANSI/ ESDA/ JEDEC JS-001 - HBM)	V_{ESD}	2000	V
Thermal resistance junction - ambient ^{1) page 12}	R_{thJA}	340	K/W
Thermal resistance junction ^{2) page 12}	R_{thJS}	180	K/W

Characteristics ($T_A = 25\text{ °C}$)

Parameter	Symbol	Values	Unit
Wavelength of max. sensitivity	(typ) $\lambda_{S\ max}$	990	nm
Spectral range of sensitivity	(typ) $\lambda_{10\%}$	(typ) 500 ... 1100	nm
Radiant sensitive area	(typ) A	0.04	mm ²
Dimensions of chip area	(typ) L x W	(typ) 0.35 x 0.35	mm x mm
Half angle	(typ) φ	± 20	°
Capacitance ($V_{CE} = 5\text{ V}$, $f = 1\text{ MHz}$, $E = 0$)	(typ) C_{CE}	1.3	pF
Dark current ($V_{CE} = 20\text{ V}$, $E = 0$)	(typ (max)) I_{CE0}	1 (≤ 50)	nA

Grouping ($T_A = 25\text{ °C}$, $\lambda = 950\text{ nm}$)

Group	Min Photocurrent $E_e = 0.1\text{ mW/cm}^2$, $V_{CE} = 5\text{ V}$ $I_{PCE, min} [\mu\text{A}]$	Max Photocurrent $E_e = 0.1\text{ mW/cm}^2$, $V_{CE} = 5\text{ V}$ $I_{PCE, max} [\mu\text{A}]$	Rise and fall time $I_C = 1\text{ mA}$, $V_{CC} = 5\text{ V}$, $R_L = 1\text{ k}\Omega$ $t_r, t_f [\mu\text{s}]$	Collector-emitter saturation voltage $I_C = I_{PCEmin} \times 0.3$, $E_e = 0.1\text{ mW/cm}^2$ $V_{CEsat} [\text{mV}]$
-2	100	200	30	150
-3	160	320	45	150
-4	250	500	70	150

Note.: I_{PCEmin} is the min. photocurrent of the specified group.

Relative Spectral Sensitivity ^{3) page 12}

$S_{rel} = f(\lambda)$, axial direction

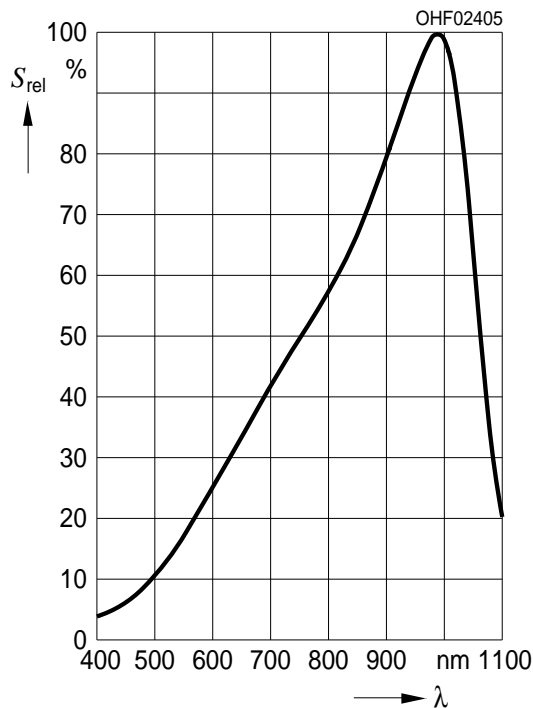

Photocurrent ^{3) page 12}

$I_{PCE} / I_{PCE(25\text{ °C})} = f(T_A)$, $V_{CE} = 5\text{ V}$

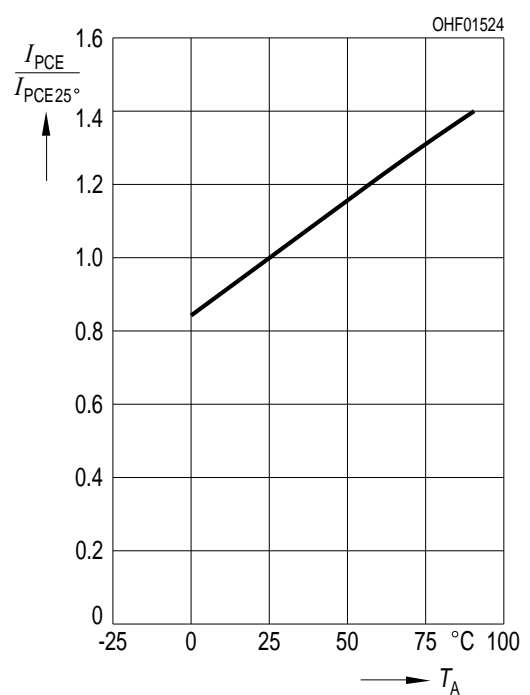

Dark Current ^{3) page 12}

$I_{CEO} = f(V_{CE}), E = 0$

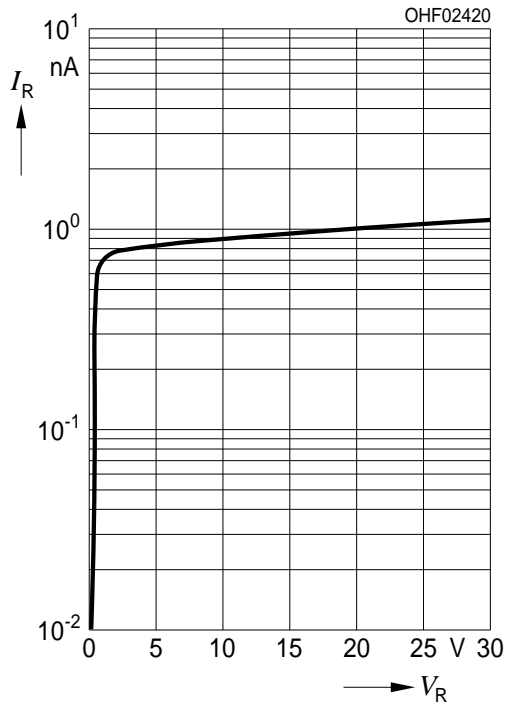

Dark Current ^{3) page 12}

$I_{CEO} = f(T_A), V_{CE} = 20 V, E = 0$

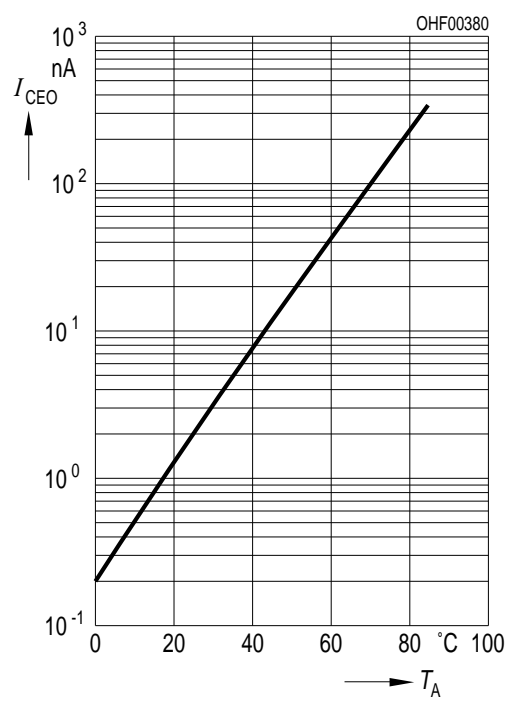

Collector-Emitter Capacitance ^{3) page 12}

$C_{CE} = f(V_{CE}), f = 1 MHz, E = 0$

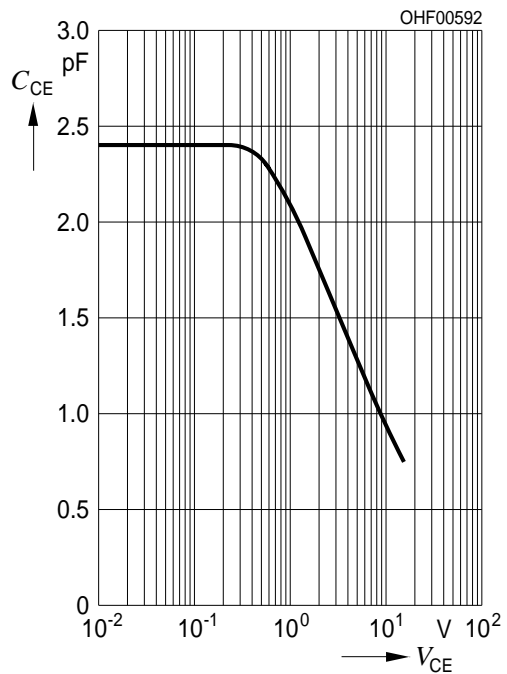

Directional Characteristics ^{3) page 12}

$S_{rel} = f(\phi)$

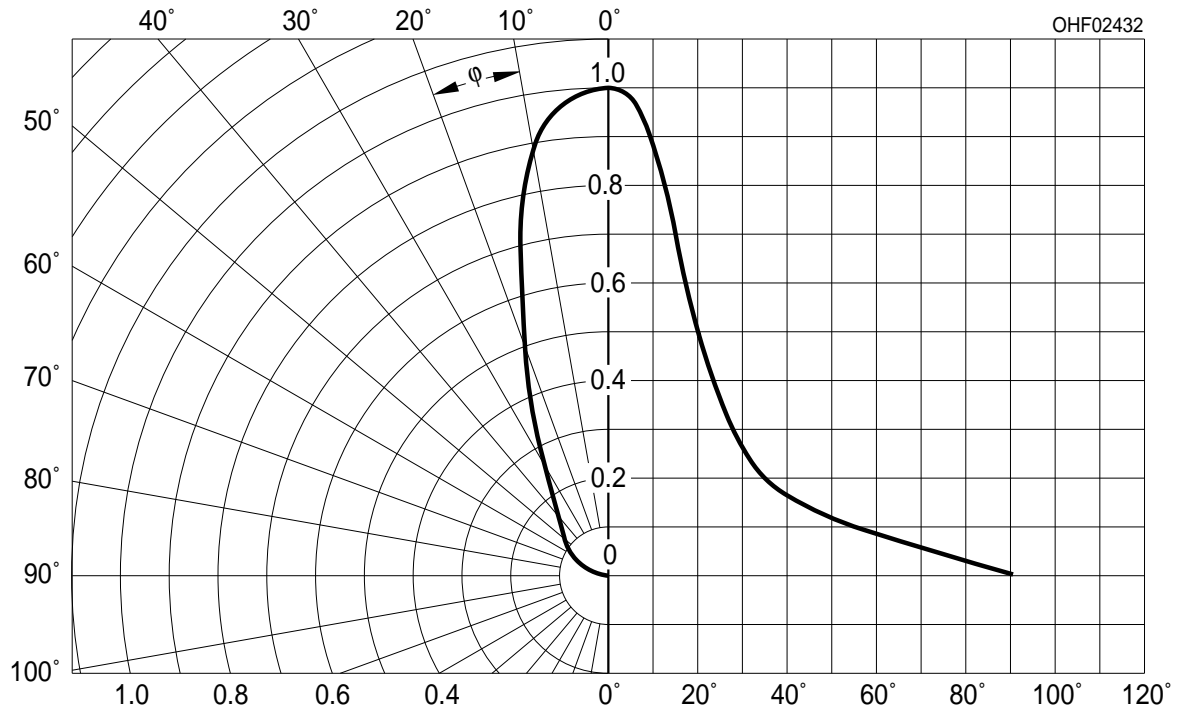

Package Outline

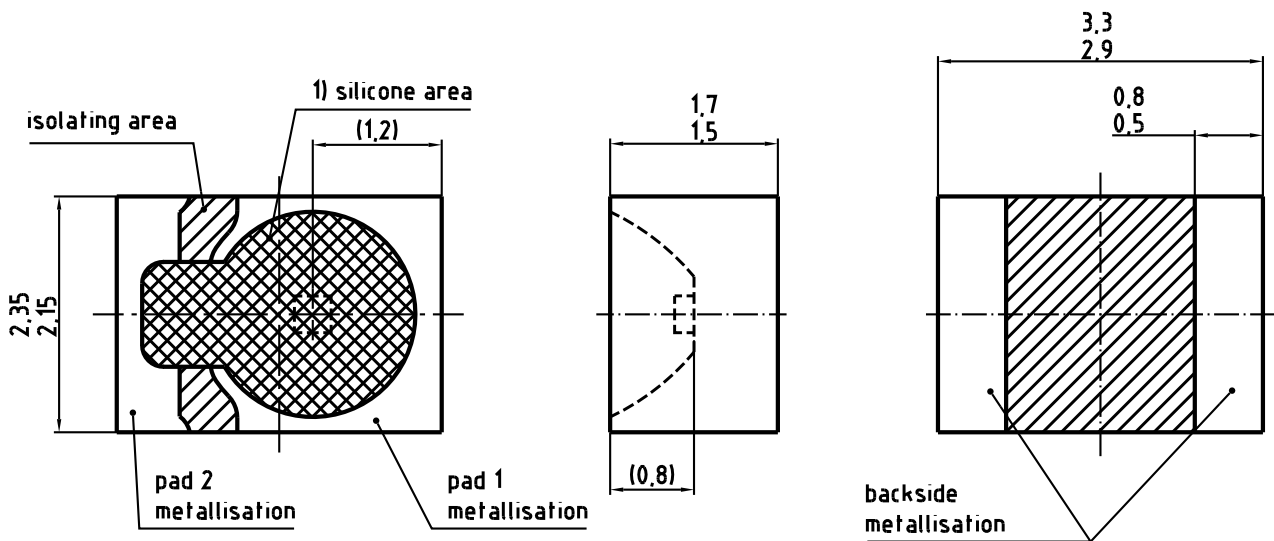

- 1) Device casted with silicone.
Avoid mechanical stress on silicone surface.

Dimensions in mm.

C63062-A3811-A1...-15

Pinning

Pin	Description
1	collector
2	emitter

Package

MIDLED, Silicone, colourless, clear

Approximate Weight:

23 mg

Recommended Solder Pad

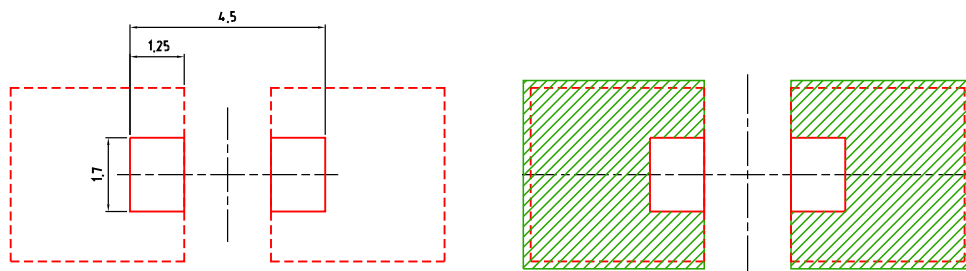

footprint
 Cu area > 16mm²
 solder resist

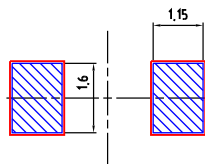

solder stencil
 recommended stencil thickness 150µm

Component Location on Pad

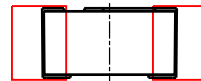

E062.3010.43-03

Dimensions in mm.

Reflow Soldering Profile

Product complies to MSL Level 2 acc. to JEDEC J-STD-020D.01

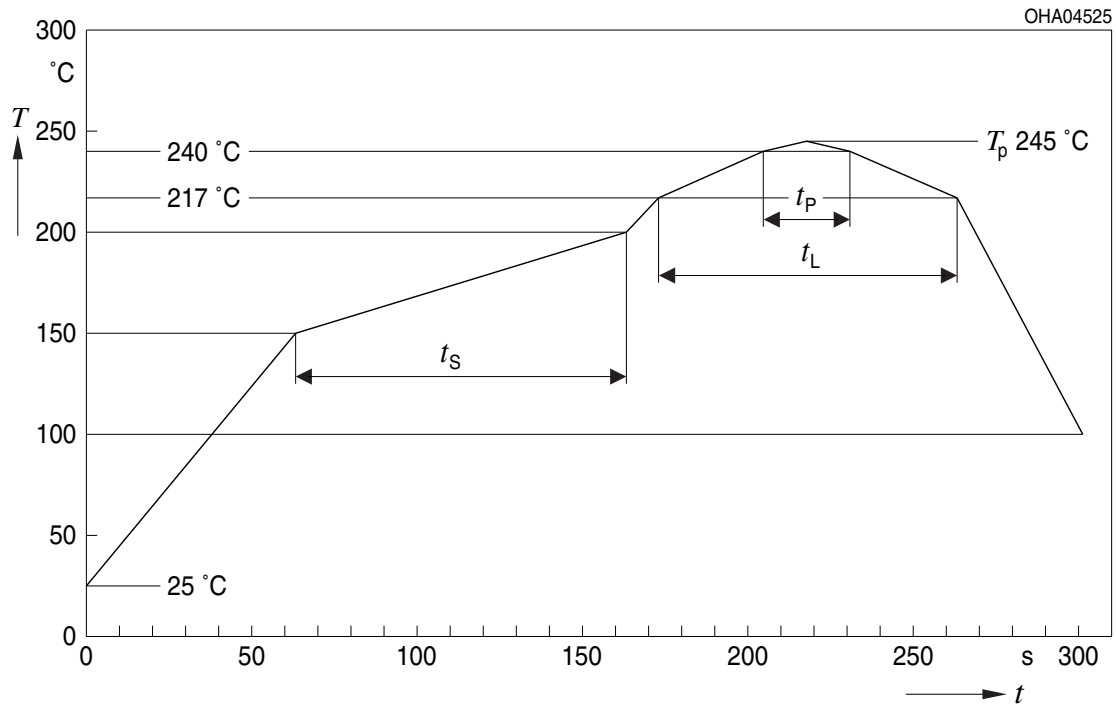

OHA04612

Profile Feature Profil-Charakteristik	Symbol Symbol	Pb-Free (SnAgCu) Assembly			Unit Einheit
		Minimum	Recommendation	Maximum	
Ramp-up rate to preheat*) 25 °C to 150 °C			2	3	K/s
Time t_S T_{Smin} to T_{Smax}	t_S	60	100	120	s
Ramp-up rate to peak*) T_{Smax} to T_P			2	3	K/s
Liquidus temperature	T_L	217			°C
Time above liquidus temperature	t_L		80	100	s
Peak temperature	T_P		245	260	°C
Time within 5 °C of the specified peak temperature $T_P - 5$ K	t_P	10	20	30	s
Ramp-down rate* T_P to 100 °C			3	6	K/s
Time 25 °C to T_P				480	s

All temperatures refer to the center of the package, measured on the top of the component

* slope calculation DT/Dt : Dt max. 5 s; fulfillment for the whole T-range

Taping

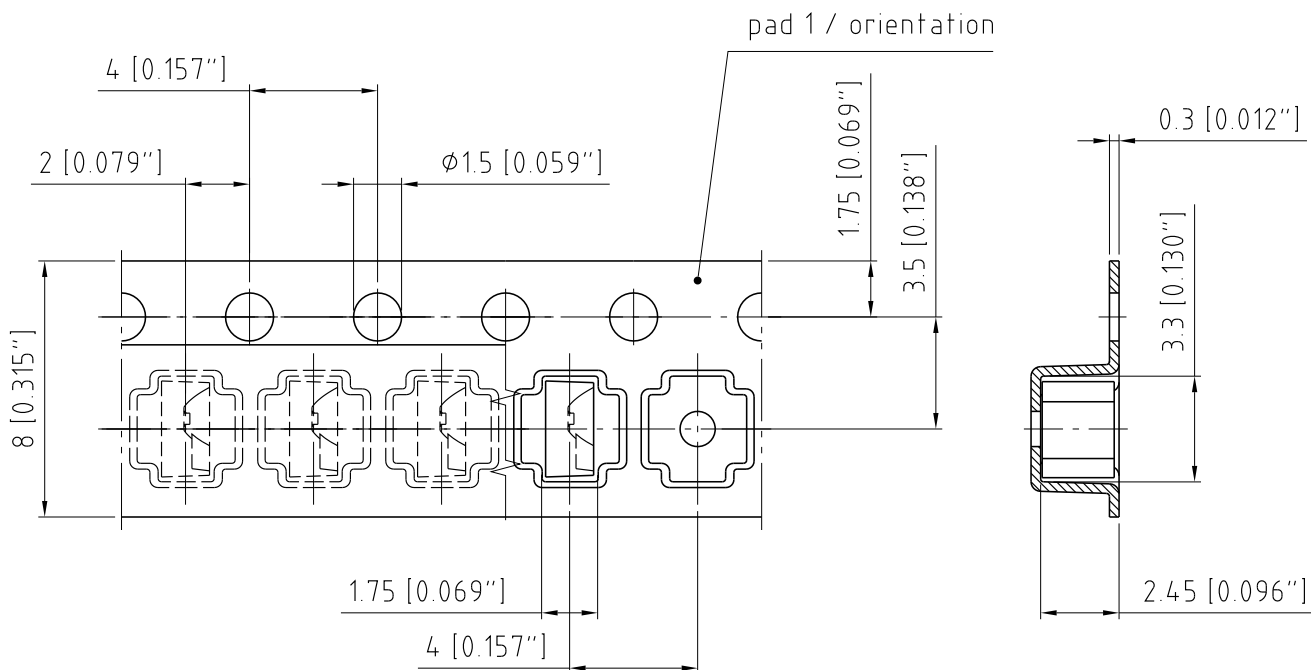

C63062-A3811-B8-08

Dimensions in mm (inch).

Note:

Pad 1 = Collector

Tape and Reel

8 mm tape with 1600 pcs. on ϕ 180 mm reel

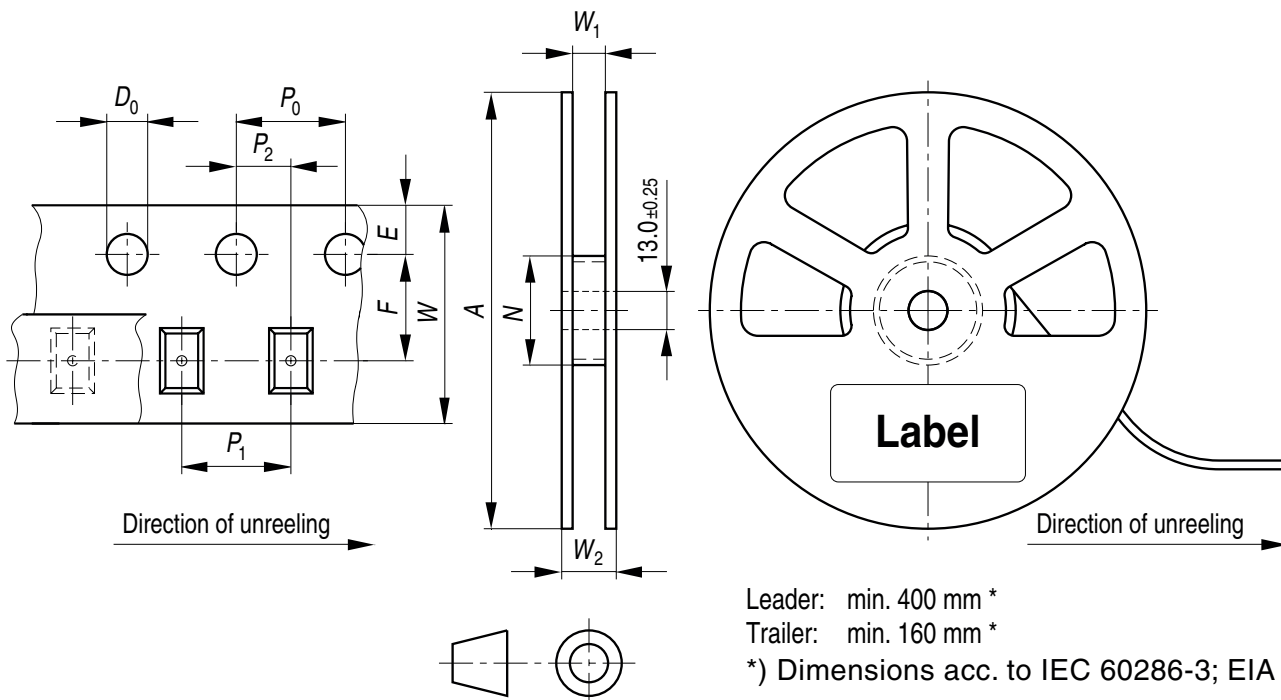

Leader: min. 400 mm *

Trailer: min. 160 mm *

*) Dimensions acc. to IEC 60286-3; EIA 481-D

OHAY0324

Tape dimensions [mm]

W	P ₀	P ₁	P ₂	D ₀	E	F
8 + 0.3 / -0.1	4 ± 0.1	2 ± 0.05 or 4 ± 0.1	2 ± 0.05	1.5 ± 0.1	1.75 ± 0.1	3.5 ± 0.05

Reel dimensions [mm]

A	W	N _{min}	W ₁	W _{2max}
180	8	60	8.4 + 2	14.4

Barcode-Product-Label (BPL)

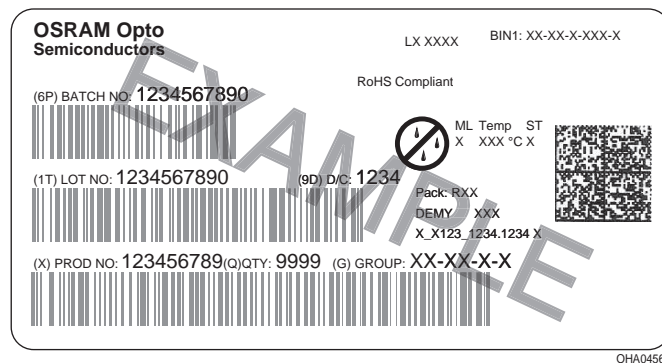

Dry Packing Process and Materials

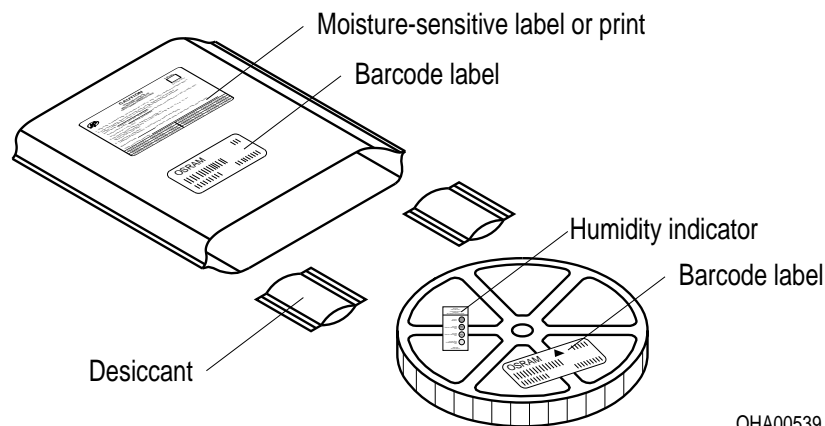

Note:

Moisture-sensitive product is packed in a dry bag containing desiccant and a humidity card. Regarding dry pack you will find further information in the internet. Here you will also find the normative references like JEDEC.

Transportation Packing and Materials

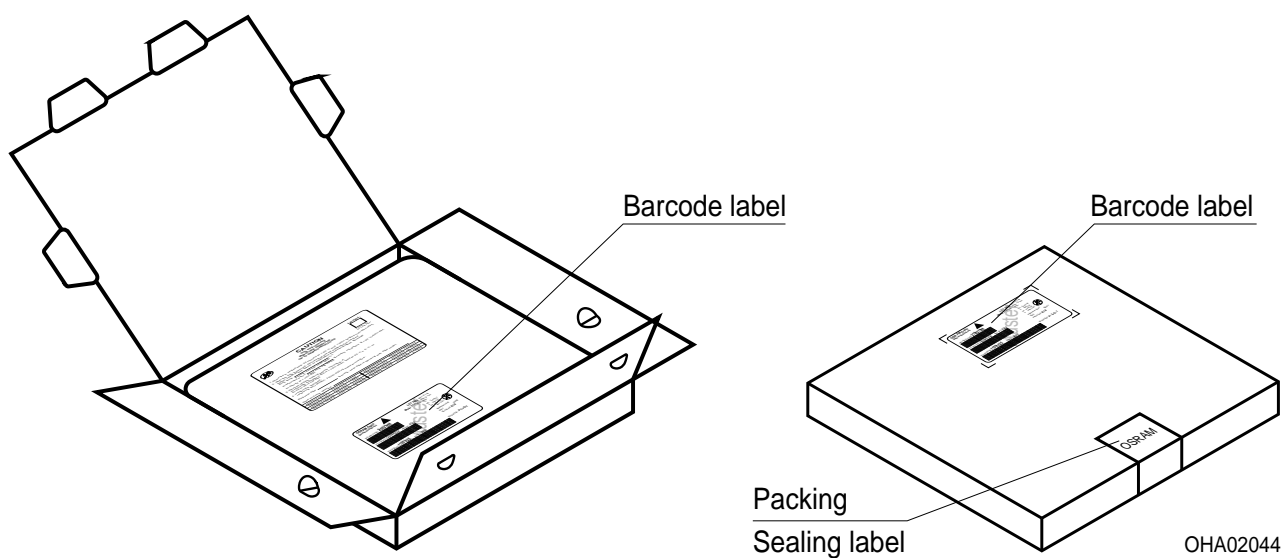

Dimensions of transportation box in mm

Width	Length	Height
200 ± 5	195 ± 5	30 ± 5

Disclaimer

Language english will prevail in case of any discrepancies or deviations between the two language wordings.

Attention please!

The information describes the type of component and shall not be considered as assured characteristics.

Terms of delivery and rights to change design reserved. Due to technical requirements components may contain dangerous substances.

For information on the types in question please contact our Sales Organization.

If printed or downloaded, please find the latest version in the Internet.

Packing

Please use the recycling operators known to you. We can also help you – get in touch with your nearest sales office.

By agreement we will take packing material back, if it is sorted. You must bear the costs of transport. For packing material that is returned to us unsorted or which we are not obliged to accept, we shall have to invoice you for any costs incurred.

Components used in life-support devices or systems must be expressly authorized for such purpose!

Critical components* may only be used in life-support devices** or systems with the express written approval of OSRAM OS.

*) A critical component is a component used in a life-support device or system whose failure can reasonably be expected to cause the failure of that life-support device or system, or to affect its safety or the effectiveness of that device or system.

**) Life support devices or systems are intended (a) to be implanted in the human body, or (b) to support and/or maintain and sustain human life. If they fail, it is reasonable to assume that the health and the life of the user may be endangered.

Glossary

- 1) **Thermal resistance:** when mounted on PC-board (FR4), padsize 16 mm each
- 2) **Thermal resistance:** junction - soldering point, of the device only, mounted on an ideal heatsink (e.g. metal block)
- 3) **Typical Values:** Due to the special conditions of the manufacturing processes of LED, the typical data or calculated correlations of technical parameters can only reflect statistical figures. These do not necessarily correspond to the actual parameters of each single product, which could differ from the typical data and calculated correlations or the typical characteristic line. If requested, e.g. because of technical improvements, these typ. data will be changed without any further notice.

Published by OSRAM Opto Semiconductors GmbH
Leibnizstraße 4, D-93055 Regensburg
www.osram-os.com © All Rights Reserved.

EU RoHS and China RoHS compliant product



此产品符合欧盟 RoHS 指令的要求；
按照中国的相关法规和标准，不含有毒有害物质或元素。

Looking for pricing, stock, or lifecycle information?

Click below to explore more details on WIN SOURCE:

- ⊖ [View SFH 3605-3-XX on WIN SOURCE](#)
- ⊖ [OSRAM Opto Semiconductors Inc. Information](#)

Optimize Your Supply Chain with WIN SOURCE Solutions

- ✓ Global Sourcing Solution
- ✓ Obsolete Management
- ✓ Cost Control Management
- ✓ Shortage Management
- ✓ Alternative Solution
- ✓ Excess Inventory Management