



**THE DATASHEET OF
PL155-32**



DASH NO	CABLES ACCOMMODATED	ASSEMBLE PER
-23	275-3930, MICRODOT	TAI-127
-24	202-3934, MICRODOT	TAI-125
-24A	9530A5117, RAYCHEM	TAI-127
-27	202-3927, MICRODOT ⁵ 73-1317911-1, SYLVANIA	TAI-125
-29	TWC-124-1A TWC-78-1	TAI-125
-30	8441, BELDEN ⁴ 761A, W.E.CO.	TAI-125
-32	TRC-50-1	TAI-127
-33	TRC-75-1	TAI-127
-43	250-4044/250-4045 293-3930 MICRODOT	TAI-174
-45	10602, RAYCHEM	TAI-125
-47	M17/176-00002 ⁵	TAI-125
-49	TWAC-78-1F2 ⁵	TAI-125
-56	GC875GC1, GRUMMAN	TAI-174
-57	GC875GB1, GRUMMAN	TAI-174
-58	GC875TM24H, GRUMMAN	TAI-125
-55	TWCP-124-3	TAI-125

DATA CONTAINED IN THIS DOCUMENT IS PROPRIETARY TO TROMPETER ELECTRONICS INC. AND SHALL NOT BE DISCLOSED, COPIED OR USED FOR PROCUREMENT OR MANUFACTURE WITHOUT EXPRESS WRITTEN PERMISSION OF TROMPETER ELECTRONICS INC.

REVISIONS		310-0036	SH 1
REV	DESCRIPTION	DATE	APPROVED
V	REVISED PER ECO 15485	2/14/04	WJ

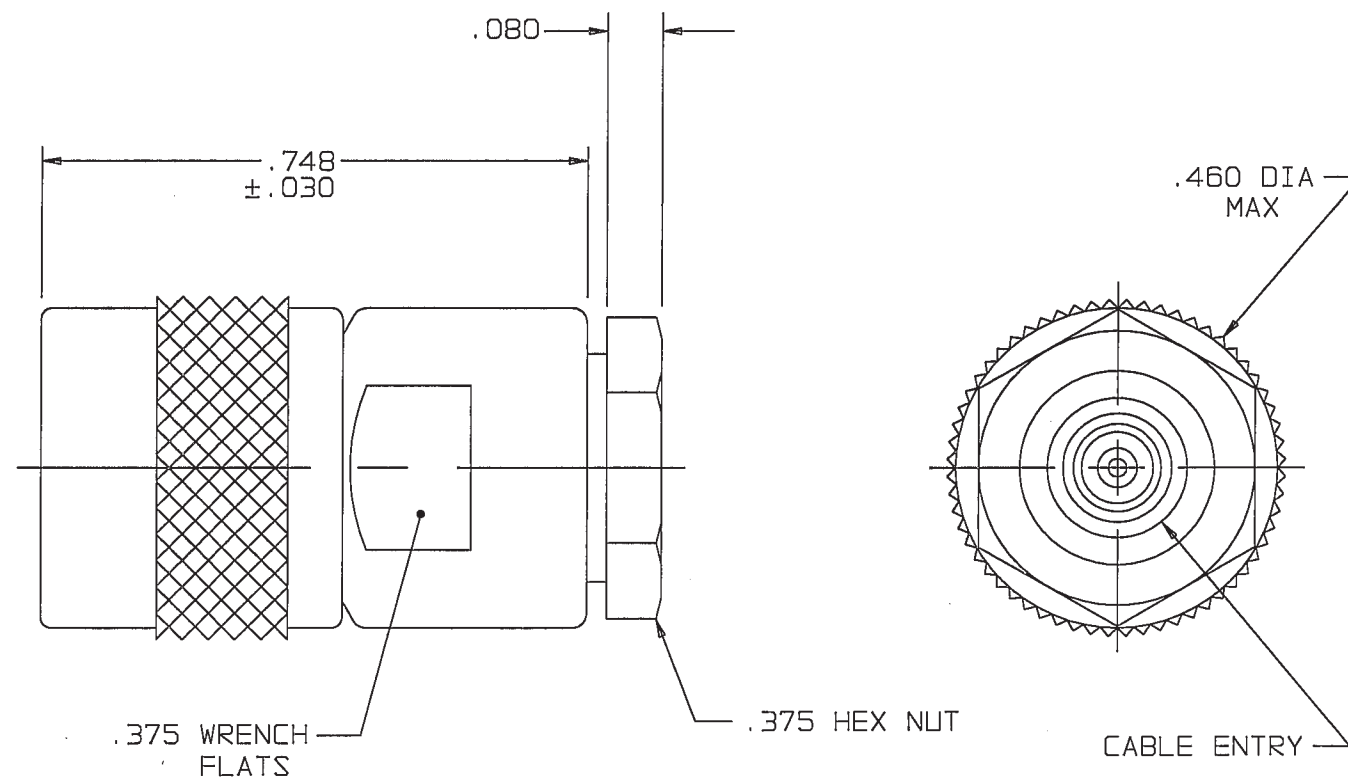

-29 SHOWN

RED INDICATES ORIGINAL

⁵ .187 LG JACKET SLITS MAY BE REQUIRED FOR EASE OF ASSY

⁴ NOT WRENCH CRIMP

3. CONCENTRIC TWINAX/TRIAX SUBMINIATURE 3-LUG TRS PLUG

2. FINISH: TFS-1A (NICKEL)



1. ALL DIM ARE IN INCHES

DRAWN		DATE	TOL: UNLESS SPECIFIED		TITLE:
310-0026	AAH	6-10-04	.XX ±.01	MATERIAL:	
305-0374	AAH	6-10-04	.XXX ±.005		
3-0040	AAH	6/14/04	.XXXX ±.0010	FINISH:	SIZE CAGE CODE DRAWING NO. REV. B 14949 310-0036 V
3-0029	AAH	6/14/04	ANGLES ± 0° 30'		
205-0029	AAH	6/14/04		DO NOT SCALE DWG	SCALE 4/1 DATE: 6/20/75 SHEET 1C
1-0451	AAH	6/14/04			
NEXT ASSY	CAD FILE NO.	310-0036V			



Looking for pricing, stock, or lifecycle information?

Click below to explore more details on WIN SOURCE:

-  [View PL155-32 on WIN SOURCE](#)
-  [Cinch Connectivity Solutions](#) Information

Optimize Your Supply Chain with WIN SOURCE Solutions

-  Global Sourcing Solution
-  Obsolete Management
-  Cost Control Management
-  Shortage Management
-  Alternative Solution
-  Excess Inventory Management