



**PRODUCT DISCONTINUATION NOTICE - LAST TIME BUY EXPIRES MAY 6, 2017**

**General Description**

The 87973I-147 is a LVCMOS/LVTTTL clock generator. The 87973I-147 has three selectable inputs and provides 14 LVCMOS/LVTTTL outputs.

The 87973I-147 is a highly flexible device. The three selectable inputs (1 differential and 2 single ended inputs) are often used in systems requiring redundant clock sources. Up to three different output frequencies can be generated among the three output banks.

The three output banks and feedback output each have their own output dividers which allows the device to generate a multitude of different bank frequency ratios and output-to-input frequency ratios. In addition, 2 outputs in Bank C (QC2, QC3) can be selected to be inverting or non-inverting. The output frequency range is 10MHz to 150MHz. The input frequency range is 6MHz to 120MHz.

The 87973I-147 also has a QSYNC output which can be used for system synchronization purposes. It monitors Bank A and Bank C outputs and goes low one period prior to coincident rising edges of Bank A and Bank C clocks. QSYNC then goes high again when the coincident rising edges of Bank A and Bank C occur. This feature is used primarily in applications where Bank A and Bank C are running at different frequencies, and is particularly useful when they are running at non-integer multiples of one another.

**Example Applications:**

- System Clock generator:** Use a 16.66MHz reference clock to generate eight 33.33MHz copies for PCI and four 100MHz copies for the CPU or PCI-X.
- Line Card Multiplier:** Multiply differential 62.5MHz from a back plane to single-ended 125MHz for the line Card ASICs and Gigabit Ethernet Serdes.
- Zero Delay buffer for Synchronous memory:** Fanout up to twelve 100MHz copies from a memory controller reference clock to the memory chips on a memory module with zero delay.

**Features**

- Fully integrated PLL
- Fourteen LVCMOS/LVTTTL outputs to include: twelve clocks, one feedback, one sync
- Selectable differential CLK, nCLK inputs or LVCMOS/LVTTTL reference clock inputs
- CLK0, CLK1 can accept the following input levels: LVCMOS or LVTTTL
- CLK, nCLK pair can accept the following differential input levels: LVPECL, LVDS, LVHSTL, SSTL, HCSL
- Output frequency range: 10MHz to 150MHz
- VCO range: 240MHz to 500MHz
- Output skew: 200ps (maximum)
- Cycle-to-cycle jitter, (all banks  $\pm$ 4): 55ps (maximum)
- Full 3.3V supply voltage
- -40°C to 85°C ambient operating temperature
- Compatible with PowerPC™ and Pentium™ Microprocessors
- Available in lead-free packages
- **For drop-in replacement use 87973i**

**Pin Assignment**

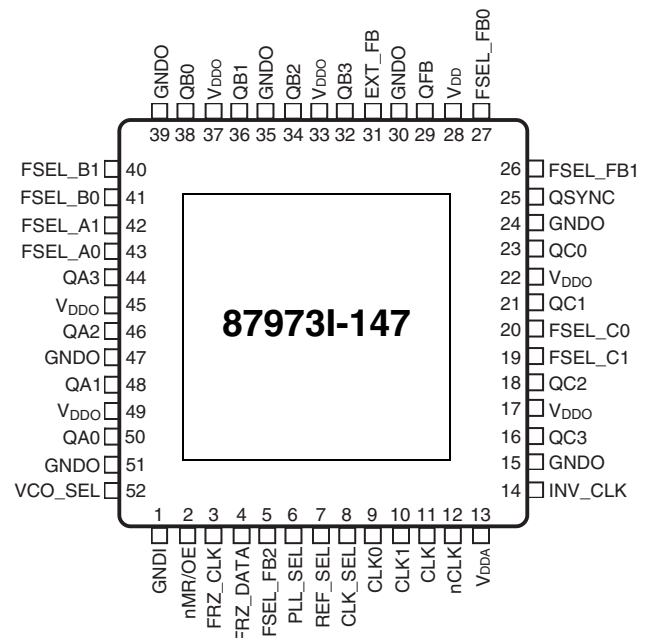

52-Lead, 10mm x 10mm LQFP

# Block Diagram

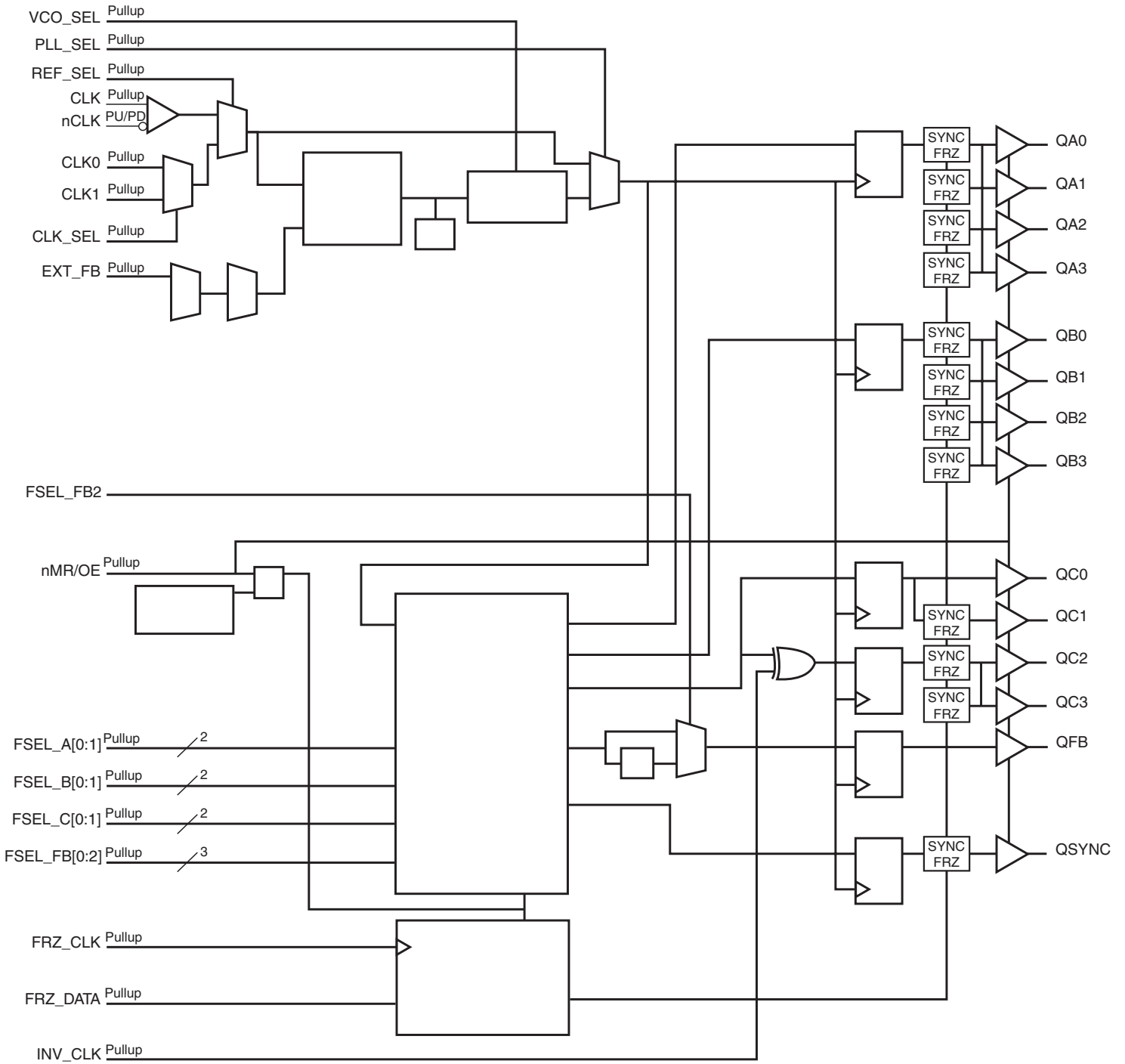

### Simplified Block Diagram

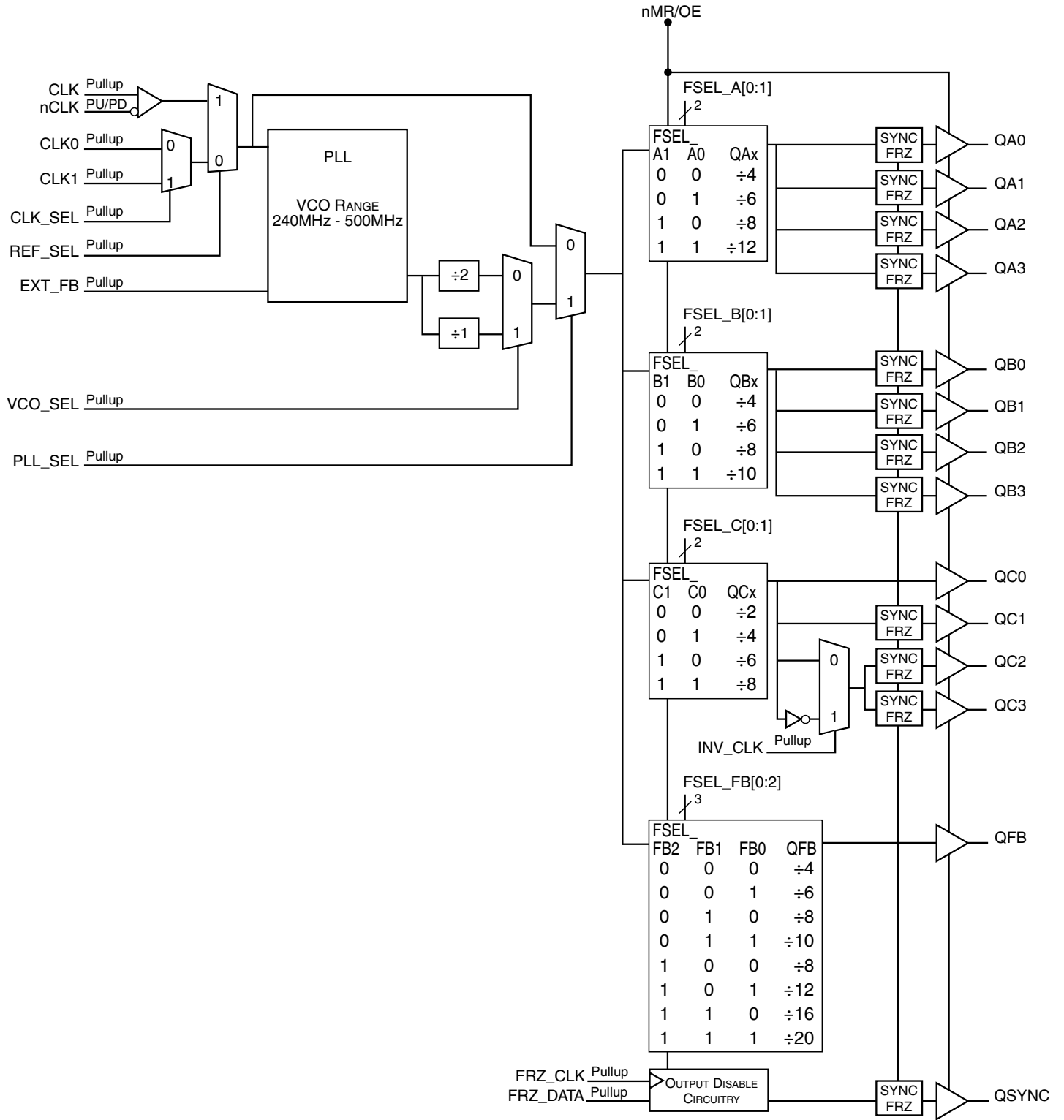

## Pin Descriptions and Pin Characteristic Tables

Table 1. Pin Descriptions

Number	Name	Type		Description
1	GNDI	Power		Power supply ground.
2	nMR/OE	Input	Pullup	Master reset and output enable. When HIGH, enables the outputs. When LOW, resets the outputs in a high-impedance state and resets output divide circuitry. Enables and disables all outputs. LVCMOS / LVTTTL interface levels.
3	FRZ_CLK	Input	Pullup	Clock input for freeze circuitry. LVCMOS / LVTTTL interface levels.
4	FRZ_DATA	Input	Pullup	Configuration data input for freeze circuitry. LVCMOS / LVTTTL interface levels.
5, 26, 27	FSEL_FB2, FSEL_FB1, FSEL_FB0	Input	Pullup	Select pins control Feedback Divide value. LVCMOS / LVTTTL interface levels. See Table 3B.
6	PLL_SEL	Input	Pullup	Selects between the PLL and reference clocks as the input to the output dividers. When HIGH, selects PLL. When LOW, bypasses the PLL and reference clocks. LVCMOS / LVTTTL interface levels.
7	REF_SEL	Input	Pullup	Selects between CLK0 or CLK1 and CLK, nCLK inputs. When LOW, selects CLK0 or CLK1. When HIGH, CLK, nCLK inputs. LVCMOS / LVTTTL interface levels.
8	CLK_SEL	Input	Pullup	Clock select input. When LOW, selects CLK0. When HIGH, selects CLK1. LVCMOS / LVTTTL interface levels.
9, 10	CLK0, CLK1	Input	Pullup	Single-ended reference clock inputs. LVCMOS/LVTTTL interface levels.
11	CLK	Input	Pullup	Non-inverting differential clock input.
12	nCLK	Input	Pullup/ Pulldown	Inverting differential clock input. $V_{DD}/2$ default when left floating.
13	$V_{DDA}$	Power		Analog supply pin.
14	INV_CLK	Input	Pullup	Inverted clock select for QC2 and QC3 outputs. LVCMOS / LVTTTL interface levels.
15, 24, 30, 35, 39, 47, 51	GND0	Power		Power supply ground.
16, 18, 21, 23	QC3, QC2, QC1, QC0	Output		Single-ended Bank C clock outputs. LVCMOS/ LVTTTL interface levels.
17, 22, 33, 37, 45, 49	$V_{DDO}$	Power		Output power supply pins.
19, 20	FSEL_C1, FSEL_C0	Input	Pullup	Select pins for Bank C outputs. LVCMOS / LVTTTL interface levels. See Table 3A.
25	QYSNC	Output		Synchronization output for Bank A and Bank C. Refer to Figure 1, Timing Diagrams. LVCMOS / LVTTTL interface levels.
28	$V_{DD}$	Power		Power supply pin.
29	QFB	Output		Single-ended feedback clock output. LVCMOS / LVTTTL interface levels.
31	EXT_FB	Input	Pullup	External feedback. LVCMOS / LVTTTL interface levels.
32, 34, 36, 38	QB3, QB2, QB1, QB0	Output		Single-ended Bank B clock outputs. LVCMOS/ LVTTTL interface levels.
40, 41	FSEL_B1, FSEL_B0	Input	Pullup	Select pins for Bank B outputs. LVCMOS / LVTTTL interface levels. See Table 3A.
42, 43	FSEL_A1, FSEL_A0	Input	Pullup	Select pins for Bank A outputs. LVCMOS / LVTTTL interface levels. See Table 3A.
44, 46, 48, 50	QA3, QA2, QA1, QA0	Output		Single-ended Bank A clock outputs. LVCMOS/ LVTTTL interface levels.
52	VCO_SEL	Input	Pullup	Selects VCO. When HIGH, selects $VCO \div 1$ . When LOW, selects $VCO \div 2$ . LVCMOS / LVTTTL interface levels.

NOTE: Pullup refers to internal input resistors. See Table 2, Pin Characteristics, for typical values.

**Table 2. Pin Characteristics**

Symbol	Parameter	Test Conditions	Minimum	Typical	Maximum	Units
C <sub>IN</sub>	Input Capacitance			4		pF
R <sub>PULLUP</sub>	Input Pullup Resistor			51		kΩ
C <sub>PD</sub>	Power Dissipation Capacitance (per output)	V <sub>DD</sub> , V <sub>DDA</sub> , V <sub>DDO</sub> = 3.465V			18	pF
R <sub>OUT</sub>	Output Impedance		5	7	12	Ω

## Function Tables

**Table 3A. Output Bank Configuration Select Function Table**

Inputs		Outputs	Inputs		Outputs	Inputs		Outputs
FSEL_A1	FSEL_A0	QA	FSEL_B1	FSEL_B0	QB	FSEL_C1	FSEL_C0	QC
0	0	÷4	0	0	÷4	0	0	÷2
0	1	÷6	0	1	÷6	0	1	÷4
1	0	÷8	1	0	÷8	1	0	÷6
1	1	÷12	1	1	÷10	1	1	÷8

**Table 3B. Feedback Configuration Select Function Table**

Inputs			Outputs
FSEL_FB2	FSEL_FB1	FSEL_FB0	QFB
0	0	0	÷4
0	0	1	÷6
0	1	0	÷8
0	1	1	÷10
1	0	0	÷8
1	0	1	÷12
1	1	0	÷16
1	1	1	÷20

**Table 3C. Control Input Select Function Table**

Control Pin	Logic 0	Logic 1
VCO_SEL	VCO/2	VCO
REF_SEL	CLK0 or CLK1	XTAL
CLK_SEL	CLK0	CLK1
PLL_SEL	BYPASS PLL	Enable PLL
nMR/OE	Master Reset/Output High-Impedance	Enable Outputs
INV_CLK	Non-Inverted QC2, QC3	Inverted QC2, QC3

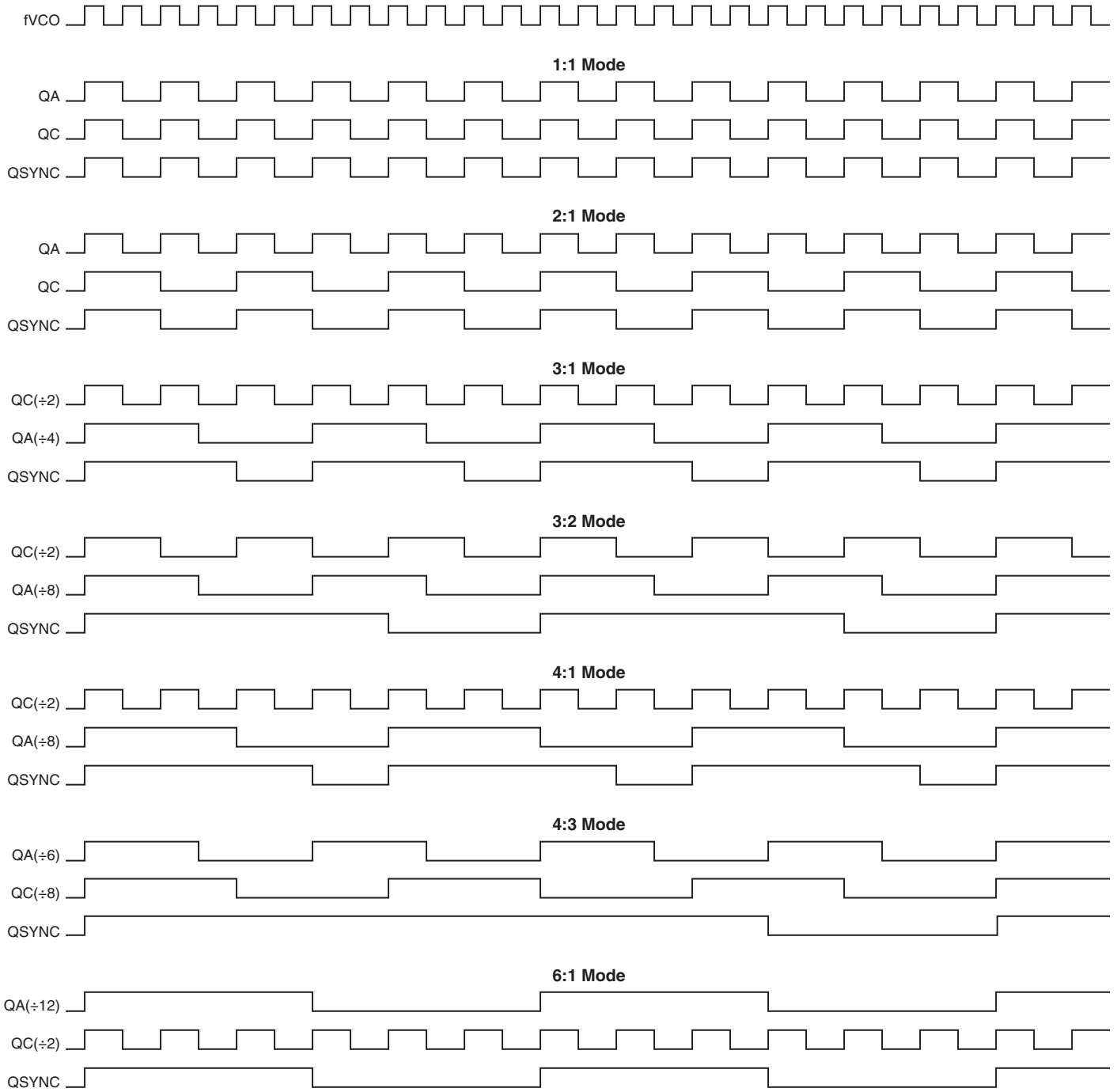

**Figure 1. Timing Diagrams**

## Absolute Maximum Ratings

NOTE: Stresses beyond those listed under *Absolute Maximum Ratings* may cause permanent damage to the device. These ratings are stress specifications only. Functional operation of product at these conditions or any conditions beyond those listed in the *DC Characteristics* or *AC Characteristics* is not implied. Exposure to absolute maximum rating conditions for extended periods may affect product reliability.

Item	Rating
Supply Voltage, $V_{DD}$	4.6V
Inputs, $V_I$	-0.5V to $V_{DD} + 0.5V$
Outputs, $V_O$	-0.5V to $V_{DDO} + 0.5V$
Package Thermal Impedance, $\theta_{JA}$	42.3°C/W (0 lfpm)
Storage Temperature, $T_{STG}$	-65°C to 150°C

## DC Electrical Characteristics

**Table 4A. Power Supply DC Characteristics,  $V_{DD} = V_{DDA} = V_{DDO} = 3.3V \pm 5\%$ ,  $T_A = -40^\circ\text{C}$  to  $85^\circ\text{C}$**

Symbol	Parameter	Test Conditions	Minimum	Typical	Maximum	Units
$V_{DD}$	Core Supply Voltage		3.135	3.3	3.465	V
$V_{DDA}$	Analog Supply Voltage		3.135	3.3	3.465	V
$V_{DDO}$	Output Supply Voltage		3.135	3.3	3.465	V
$I_{DD}$	Power Supply Current				225	mA
$I_{DDA}$	Analog Supply Current				20	mA

**Table 4B. DC Characteristics,  $V_{DD} = V_{DDA} = V_{DDO} = 3.3V \pm 5\%$ ,  $T_A = -40^\circ\text{C}$  to  $85^\circ\text{C}$**

Symbol	Parameter	Test Conditions	Minimum	Typical	Maximum	Units
$V_{IH}$	Input High Voltage		2		$V_{DD} + 0.3$	V
$V_{IL}$	Input Low Voltage		-0.3		0.8	V
$I_{IN}$	Input Current				$\pm 120$	$\mu\text{A}$
$V_{OH}$	Output High Voltage; NOTE 1	$I_{OH} = -20\text{mA}$	2.4			V
$V_{OL}$	Output Low Voltage; NOTE 1	$I_{OL} = 20\text{mA}$			0.5	V
$V_{PP}$	Peak-to-Peak Input Voltage; NOTE 2, 3	CLK, nCLK	0.3		1	V
$V_{CMRP}$	Common Mode Input Voltage; NOTE 2, 3	CLK, nCLK	$V_{DD} - 2$		$V_{DD} - 0.6$	V

NOTE 1: Outputs terminated with  $50\Omega$  to  $V_{DDO}/2$ . See Parameter Measurement Information section. *Load Test Circuit diagram*.

NOTE 2:  $V_{IL}$  should not be less than -0.3V.

NOTE 3: Common mode input voltage is defined as  $V_{IH}$ .

**Table 5. Input Frequency Characteristics,  $V_{DD} = V_{DDA} = V_{DDO} = 3.3V \pm 5\%$ ,  $T_A = -40^{\circ}C$  to  $85^{\circ}C$** 

Symbol	Parameter	Test Conditions	Minimum	Typical	Maximum	Units
$F_{IN}$	Input Frequency	CLK0, CLK1; NOTE 1			120	MHz
		FRZ_CLK			20	MHz

NOTE 1: Input frequency depends on the feedback divide ratio to ensure "clock \* feedback divide" is in the VCO range of 240MHz to 500MHz.

## AC Electrical Characteristics

**Table 6. AC Characteristics,  $V_{DD} = V_{DDA} = V_{DDO} = 3.3V \pm 5\%$ ,  $T_A = -40^{\circ}C$  to  $85^{\circ}C$** 

Symbol	Parameter	Test Conditions	Minimum	Typical	Maximum	Units	
$f_{OUT}$	Output Frequency	$\div 2$			250	MHz	
		$\div 4$			125	MHz	
		$\div 6$			83.33	MHz	
		$\div 8$			62.5	MHz	
		$\div 10$			50	MHz	
		$\div 12$			41.66	MHz	
$t(\theta)$	Static Phase Offset; NOTE 1	CLK0	QFB $\div 8$ , In Frequency = 50MHz	-10	145	300	ps
		CLK1		-65	90	245	ps
		CLK, nCLK		-130	18	165	ps
$t_{sk(o)}$	Output Skew; NOTE 2, 3				200	ps	
$t_{jit(cc)}$	Cycle-to-Cycle Jitter; NOTE 3	All Banks $\div 4$			55	ps	
$f_{VCO}$	PLL VCO Lock Range		240		500	MHz	
$t_{LOCK}$	PLL Lock Time; NOTE 4				10	ms	
$t_R / t_F$	Output Rise/Fall Time	0.8V to 2V	150		700	ps	
odc	Output Duty Cycle		45		55	%	
$t_{PZL}, t_{PZH}$	Output Enable Time; NOTE 4				10	ns	
$t_{PLZL}, t_{PHZ}$	Output Disable Time; NOTE 4				8	ns	

NOTE: Electrical parameters are guaranteed over the specified ambient operating temperature range, which is established when the device is mounted in a test socket with maintained transverse airflow greater than 500 lfm. The device will meet specifications after thermal equilibrium has been reached under these conditions.

NOTE 1: Defined as the time difference between the input reference clock and the average feedback input signal when the PLL is locked and the input reference frequency is stable.

NOTE 2: Defined as skew between outputs at the same supply voltage and with equal load conditions. Measured at  $V_{DDO}/2$ .

NOTE 3: This parameter is defined in accordance with JEDEC Standard 65.

NOTE 4: These parameters are guaranteed by characterization. Not tested in production.

## Parameter Measurement Information

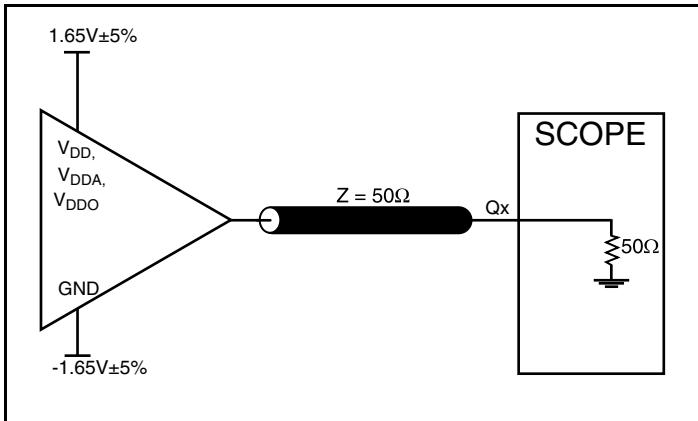

LVC MOS Output Load AC Test Circuit

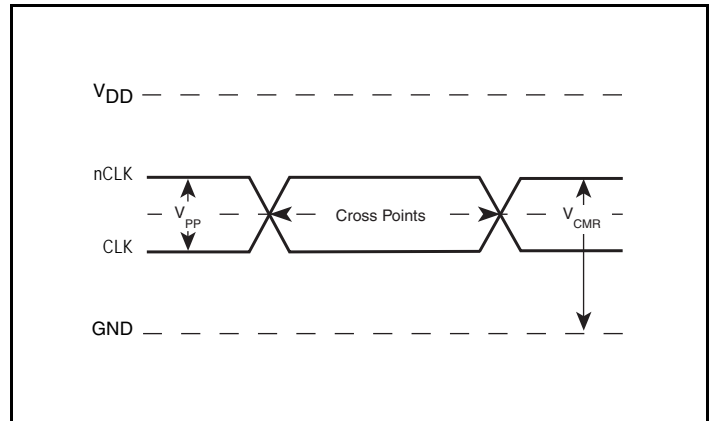

Differential Input Level

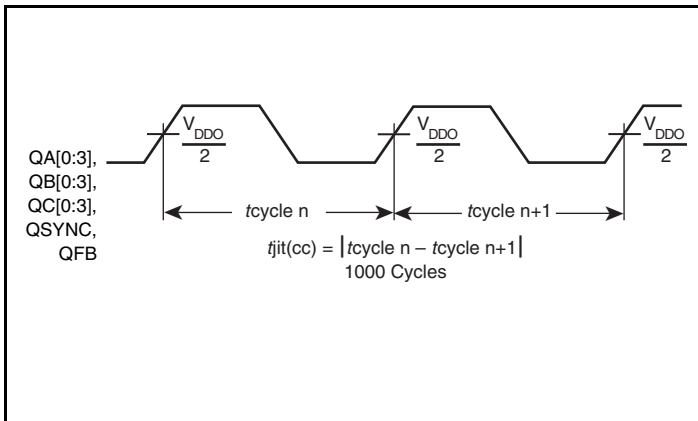

Cycle-to-Cycle Jitter

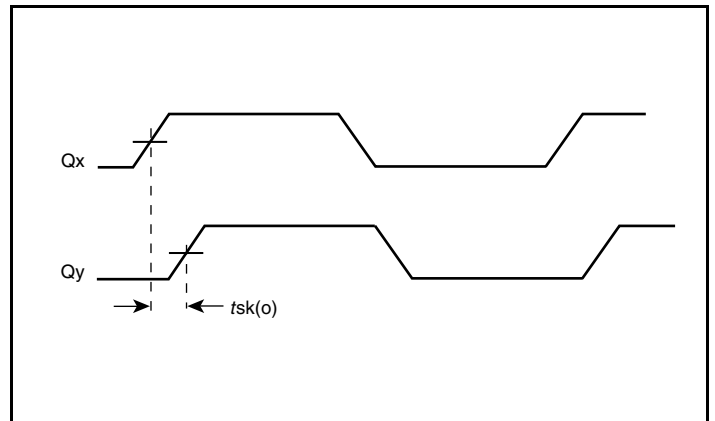

Output Skew

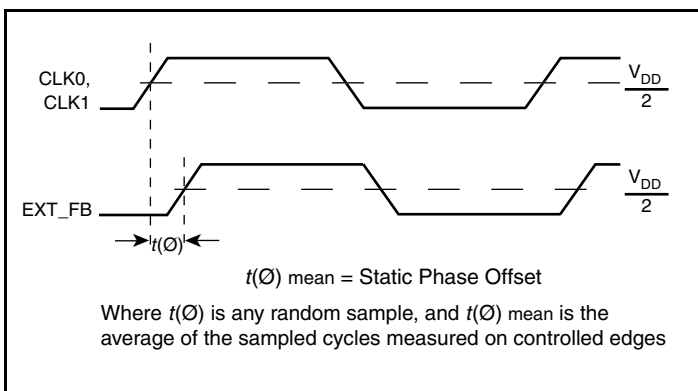

LVC MOS Static Phase Offset

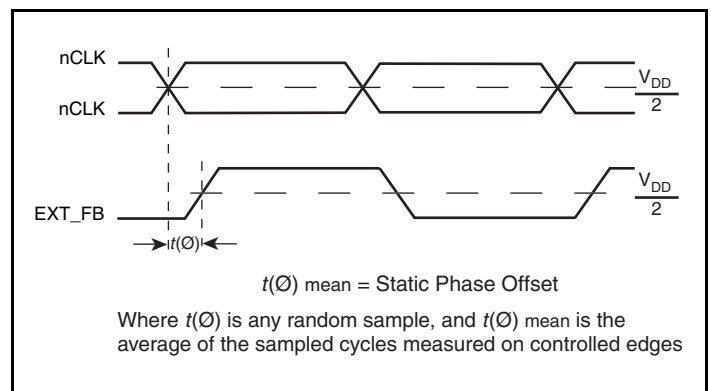

Differential Static Phase Offset

## Parameter Measurement Information, continued

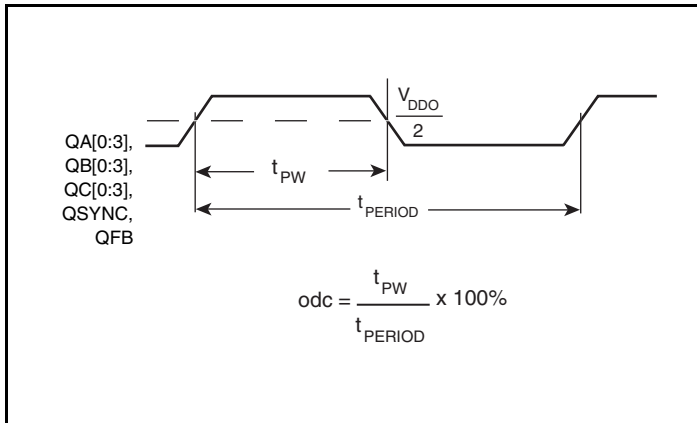

Output Duty Cycle/Pulse Width Period

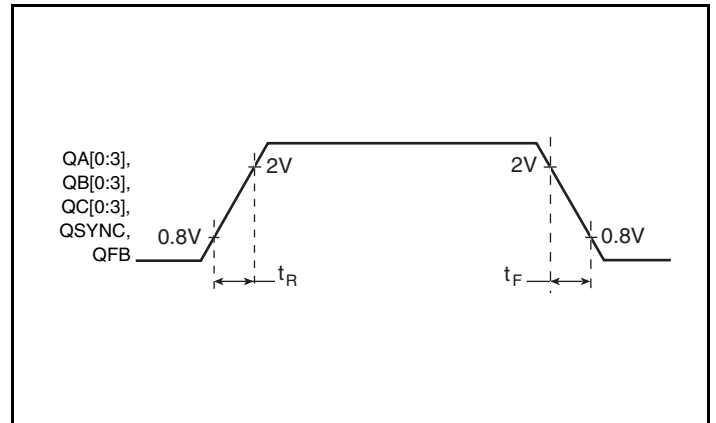

Output Rise/Fall Time

## Application Information

### Recommendations for Unused Input and Output Pins

#### Inputs:

##### CLK/nCLK Inputs

For applications not requiring the use of the differential input, both CLK and nCLK can be left floating. Though not required, but for additional protection, a 1kΩ resistor can be tied from CLK to ground.

##### CLK Inputs

For applications not requiring the use of the clock input, it can be left floating. Though not required, but for additional protection, a 1kΩ resistor can be tied from the CLK to ground.

##### LVC MOS Control Pins

All control pins have internal pull-ups; additional resistance is not required but can be added for additional protection. A 1kΩ resistor can be used.

#### Outputs:

##### LVC MOS Outputs

All unused LVC MOS output can be left floating. There should be no trace attached.

### Power Supply Filtering Technique

As in any high speed analog circuitry, the power supply pins are vulnerable to random noise. To achieve optimum jitter performance, power supply isolation is required. The 879731-147 provides separate power supplies to isolate any high switching noise from the outputs to the internal PLL.  $V_{DD}$ ,  $V_{DDA}$  and  $V_{DDO}$  should be individually connected to the power supply plane through vias, and  $0.01\mu\text{F}$  bypass capacitors should be used for each pin. *Figure 2* illustrates this for a generic  $V_{DD}$  pin and also shows that  $V_{DDA}$  requires that an additional  $10\Omega$  resistor along with a  $10\mu\text{F}$  bypass capacitor be connected to the  $V_{DDA}$  pin.

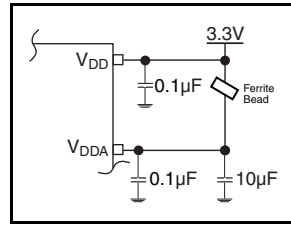

Figure 2. Power Supply Filtering

### Wiring the Differential Input to Accept Single-Ended Levels

*Figure 3* shows how a differential input can be wired to accept single ended levels. The reference voltage  $V_1 = V_{DD}/2$  is generated by the bias resistors  $R1$  and  $R2$ . The bypass capacitor ( $C1$ ) is used to help filter noise on the DC bias. This bias circuit should be located as close to the input pin as possible. The ratio of  $R1$  and  $R2$  might need to be adjusted to position the  $V_1$  in the center of the input voltage swing. For example, if the input clock swing is  $2.5\text{V}$  and  $V_{DD} = 3.3\text{V}$ ,  $R1$  and  $R2$  value should be adjusted to set  $V_1$  at  $1.25\text{V}$ . The values below are for when both the single ended swing and  $V_{DD}$  are at the same voltage. This configuration requires that the sum of the output impedance of the driver ( $R_o$ ) and the series resistance ( $R_s$ ) equals the transmission line impedance. In addition, matched termination at the input will attenuate the signal in half. This can be done in one of two ways. First,  $R3$  and  $R4$  in parallel should equal the transmission

line impedance. For most  $50\Omega$  applications,  $R3$  and  $R4$  can be  $100\Omega$ . The values of the resistors can be increased to reduce the loading for slower and weaker LVCMOS driver. When using single-ended signaling, the noise rejection benefits of differential signaling are reduced. Even though the differential input can handle full rail LVCMOS signaling, it is recommended that the amplitude be reduced. The datasheet specifies a lower differential amplitude, however this only applies to differential signals. For single-ended applications, the swing can be larger, however  $V_{IL}$  cannot be less than  $-0.3\text{V}$  and  $V_{IH}$  cannot be more than  $V_{DD} + 0.3\text{V}$ . Though some of the recommended components might not be used, the pads should be placed in the layout. They can be utilized for debugging purposes. The datasheet specifications are characterized and guaranteed by using a differential signal.

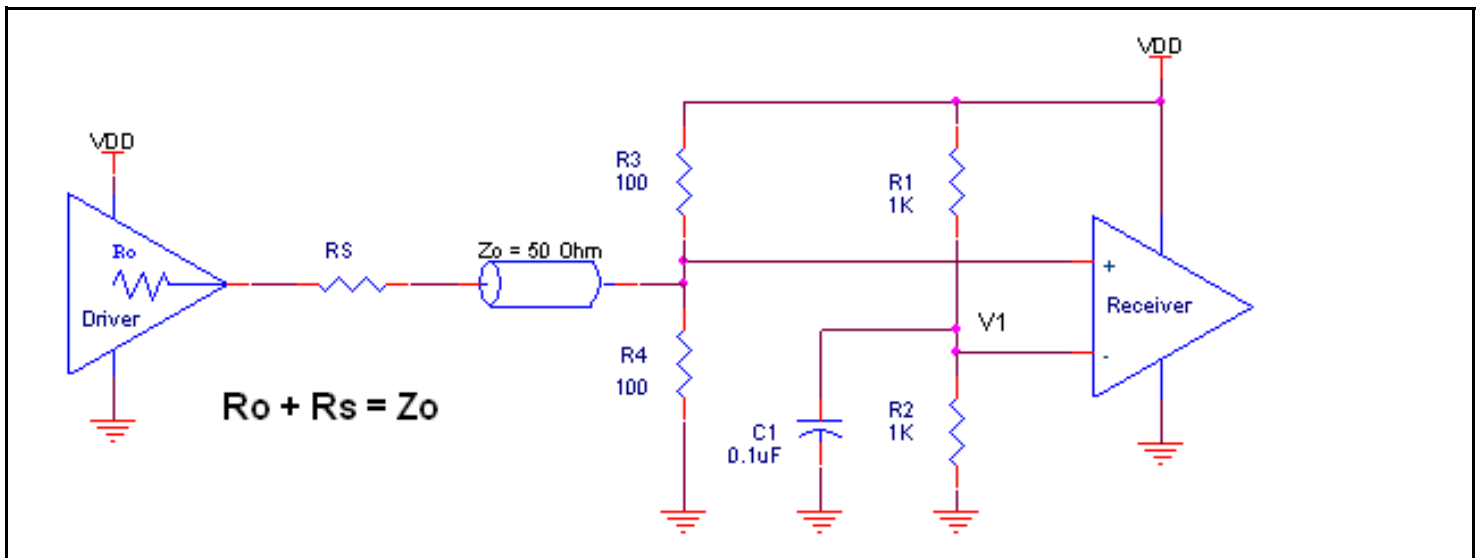
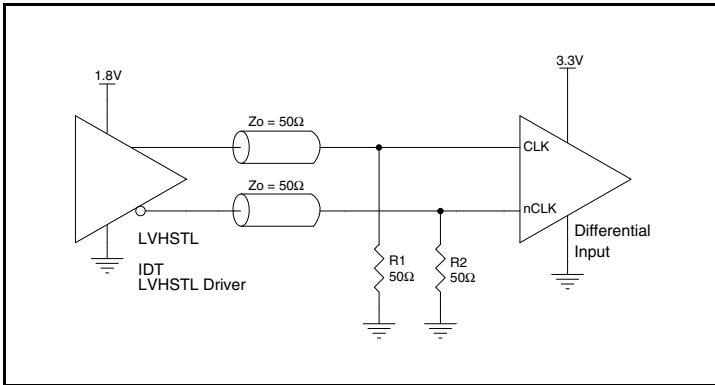

Figure 3. Recommended Schematic for Wiring a Differential Input to Accept Single-ended Levels

## Differential Clock Input Interface

The CLK/nCLK accepts LVDS, LVPECL, LVHSTL, SSTL, HCSL and other differential signals. Both  $V_{SWING}$  and  $V_{OH}$  must meet the  $V_{PP}$  and  $V_{CMR}$  input requirements. *Figures 4A to 4E* show interface examples for the CLK/nCLK input driven by the most common driver types. The input interfaces suggested here are examples only.

Please consult with the vendor of the driver component to confirm the driver termination requirements. For example, in Figure 4A, the input termination applies for IDT open emitter LVHSTL drivers. If you are using an LVHSTL driver from another vendor, use their termination recommendation.



**Figure 4A.** CLK/nCLK Input Driven by an IDT Open Emitter LVHSTL Driver

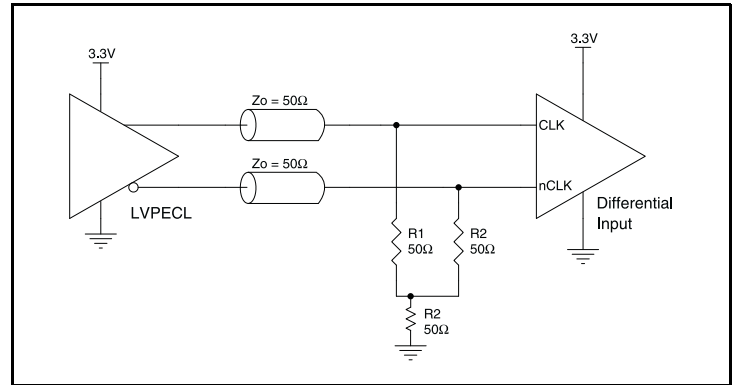

**Figure 4B.** CLK/nCLK Input Driven by a 3.3V LVPECL Driver

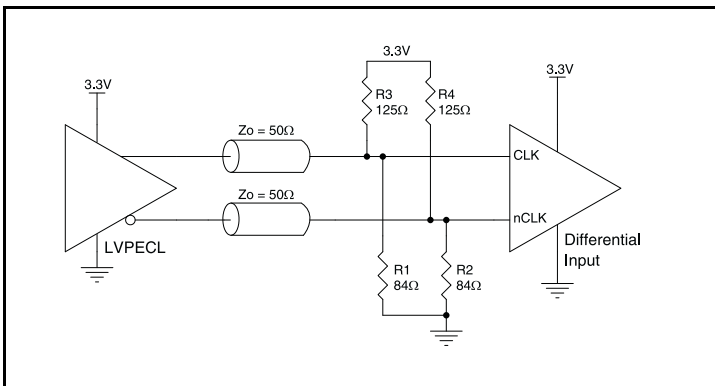

**Figure 4C.** CLK/nCLK Input Driven by a 3.3V LVPECL Driver

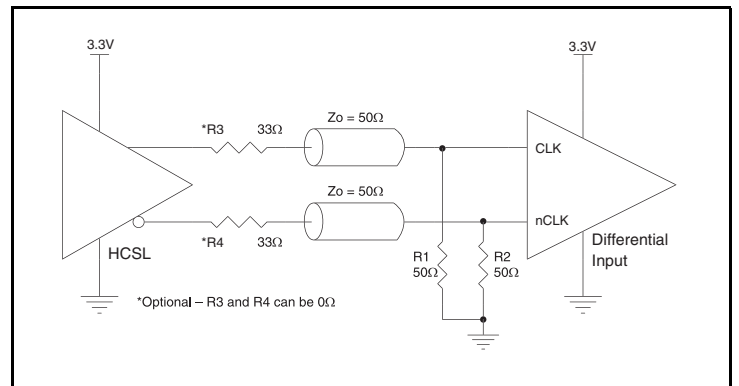

**Figure 4D.** CLK/nCLK Input Driven by a 3.3V HCSL Driver

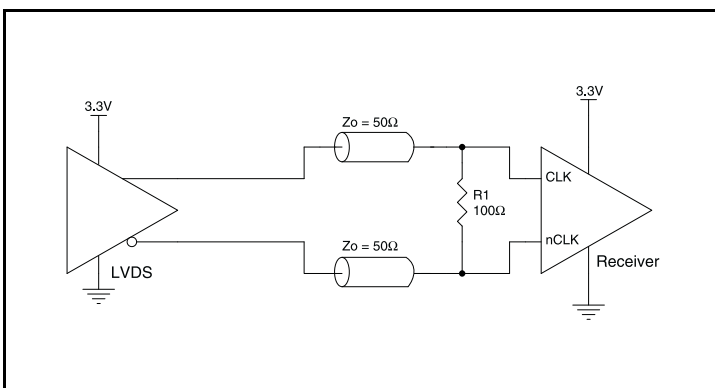

**Figure 4E.** CLK/nCLK Input Driven by a 3.3V LVDS Driver

## Using the Output Freeze Circuitry

### OVERVIEW

To enable low power states within a system, each output of 879731-147 (Except QC0 and QFB) can be individually frozen (stopped in the logic "0" state) using a simple serial interface to a 12 bit shift register. A serial interface was chosen to eliminate the need for each output to have its own Output Enable pin, which would dramatically increase pin count and package cost. Common sources in a system that can be used to drive the 879731-147 serial interface are FPGA's and ASICs.

### PROTOCOL

The Serial interface consists of two pins, FRZ\_Data (Freeze Data) and FRZ\_CLK (Freeze Clock). Each of the outputs which can be frozen has its own freeze enable bit in the 12 bit shift register. The sequence is started by supplying a logic "0" start bit followed by 12NRZ freeze enable bits. The period of each FRZ\_DATA bit equals the period of the FRZ\_CLK signal. The FRZ\_DATA serial transmission should be timed so the 879731-147 can sample each

FRZ\_DATA bit with the rising edge of the FRZ\_CLK signal. To place an output in the freeze state, a logic "0" must be written to the respective freeze enable bit in the shift register. To unfreeze an output, a logic "1" must be written to the respective freeze enable bit. Outputs will not become enabled/disabled until all 12 data bits are shifted into the shift register. When all 12 data bits are shifted in the register, the next rising edge of FRZ\_CLK will enable or disable the outputs. If the bit that is following the 12th bit in the register is a logic "0", it is used for the start bit of the next cycle; otherwise, the device will wait and won't start the next cycle until it sees a logic "0" bit. Freezing and unfreezing of the output clock is synchronous (see the timing diagram below). When going into a frozen state, the output clock will go LOW at the time it would normally go LOW, and the freeze logic will keep the output low until unfrozen. Likewise, when coming out of the frozen state, the output will go HIGH only when it would normally go HIGH. This logic, therefore, prevents runt pulses when going into and out of the frozen state.

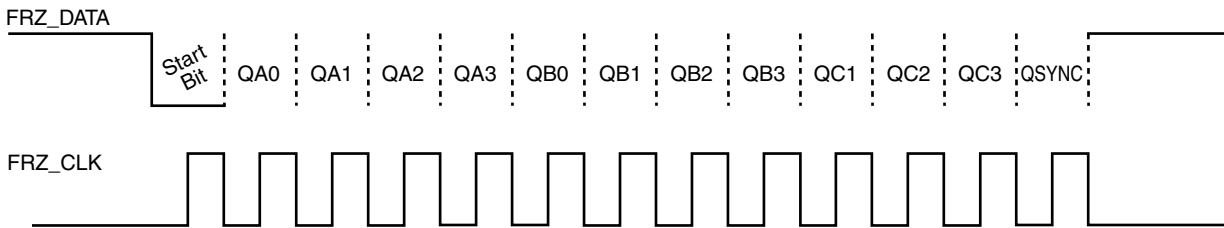

Figure 5A. Freeze Data Input Protocol

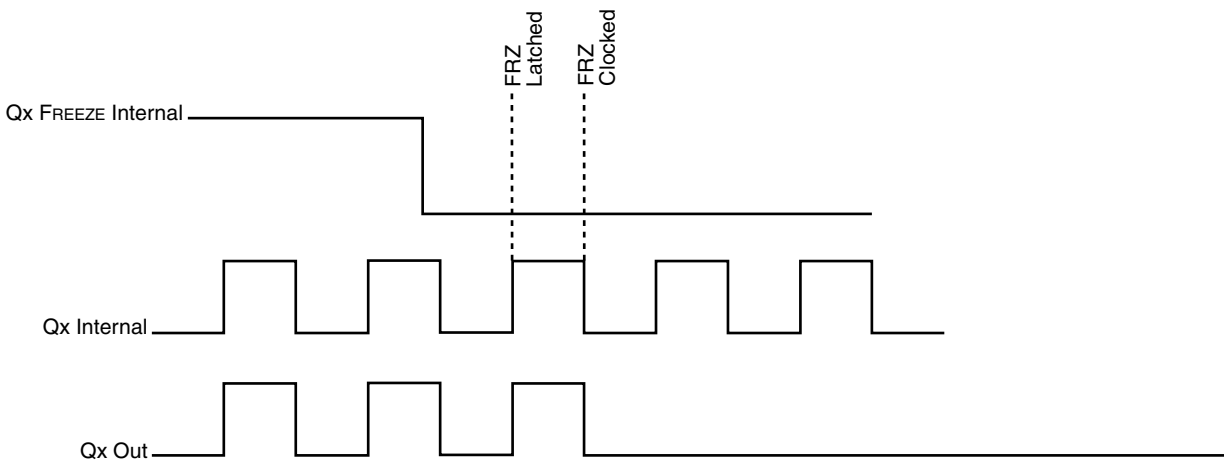

Figure 5. Output Disable Timing Diagram

### Schematic Example

Figure 6 shows a schematic example of using 87973I-147. This example shows general design of input, output termination, logic

control input pull up/down and power supply filtering. In this example, the clock input is driven by an LVCMOS driver.

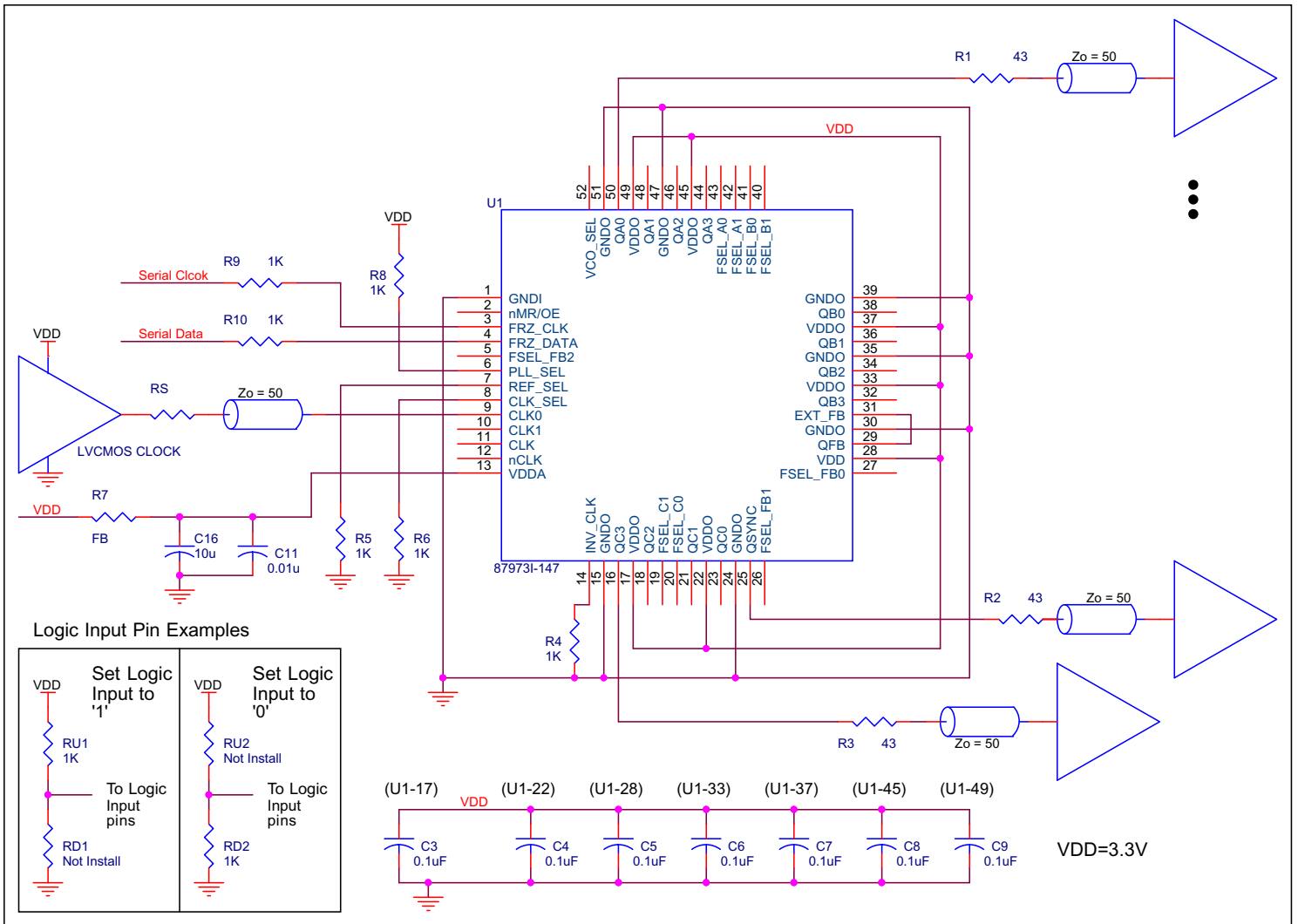

Figure 6. 87973I-147 Schematic Layout

## Reliability Information

**Table 7.  $\theta_{JA}$  vs. Air Flow Table for a 52 Lead LQFP**

$\theta_{JA}$ by Velocity			
Linear Feet per Minute	0	200	500
Single-Layer PCB, JEDEC Standard Test Boards	58.0°C/W	47.1°C/W	42.0°C/W
Multi-Layer PCB, JEDEC Standard Test Boards	42.3°C/W	36.4°C/W	34.0°C/W

NOTE: Most modern PCB designs use multi-layered boards. The data in the second row pertains to most designs.

## Transistor Count

The transistor count for 87973I-147: 8364

Pin Compatible with MPC973

## Package Outline and Package Dimensions

### Package Outline - Y Suffix for 52 Lead LQFP

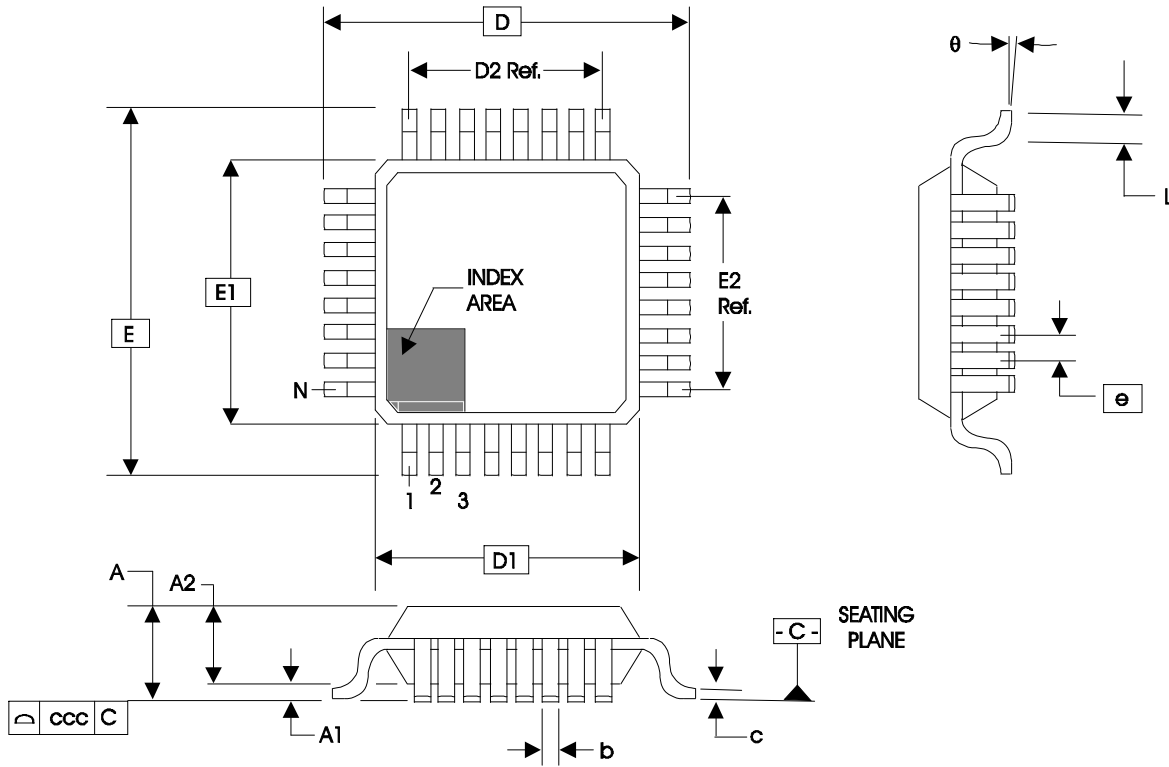

Table 8. Package Dimensions for 52 Lead LQFP

JEDEC Variation: BCC			
All Dimensions in Millimeters			
Symbol	Minimum	Nominal	Maximum
N	52		
A			1.60
A1	0.05	0.10	0.15
A2	1.35	1.40	1.45
b	0.22		0.38
c	0.09		0.20
D & E	12.00 Basic		
D1 & E1	10.00 Basic		
D2 & E2	7.80 Ref.		
e	0.65 Basic		
L	0.45	0.60	0.75
theta	0°		7°
ccc			0.10

Reference Document: JEDEC Publication 95, MS-026

## Ordering Information

**Table 9. Ordering Information**

Part/Order Number	Marking	Package	Shipping Packaging	Temperature
87973DYI-147LF	ICS87973DI147L	"Lead-Free" 52 Lead LQFP	Tray	-40°C to 85°C
87973DYI-147LFT	ICS87973DI147L	"Lead-Free" 52 Lead LQFP	Tape & Reel	-40°C to 85°C

## Revision History Sheet

Rev	Table	Page	Description of Change	Date
B	T1	2 -3	Updated Block Diagrams - added "PU/PD" to nCLK clock input.	7/27/15
		4	Pin Description Table - pin number 12, nCLK - added "Pullup/Pulldown" in <i>Type column</i> .	
	T6	8	AC Characteristics Table - $f_{OUT}$ Frequency - added $\div 10$ and $\div 12$ rows. $\div 2$ row, corrected typo: maximum value from 150MHz to 250MHz.	
	11	<i>Power Supply Filtering Technique</i> - corrected Figure 2 drawing.		
	14	Updated <i>Wiring the Differential Inputs to Accept Single-ended Levels</i> application note. Schematic Example - corrected Schematic Layout drawing. Deleted "ICS" prefix in part number throughout the datasheet. Updated headers/footers.		
B	T9	17	Ordering Information - removed quantity from tape and reel. Deleted LF note below table. Product Discontinuation Notice - Last time buy expires May 6, 2017. PDN CQ-16-01. Updated header and footer.	6/28/16





## IMPORTANT NOTICE AND DISCLAIMER

RENESAS ELECTRONICS CORPORATION AND ITS SUBSIDIARIES (“RENESAS”) PROVIDES TECHNICAL SPECIFICATIONS AND RELIABILITY DATA (INCLUDING DATASHEETS), DESIGN RESOURCES (INCLUDING REFERENCE DESIGNS), APPLICATION OR OTHER DESIGN ADVICE, WEB TOOLS, SAFETY INFORMATION, AND OTHER RESOURCES “AS IS” AND WITH ALL FAULTS, AND DISCLAIMS ALL WARRANTIES, EXPRESS OR IMPLIED, INCLUDING, WITHOUT LIMITATION, ANY IMPLIED WARRANTIES OF MERCHANTABILITY, FITNESS FOR A PARTICULAR PURPOSE, OR NON-INFRINGEMENT OF THIRD-PARTY INTELLECTUAL PROPERTY RIGHTS.

These resources are intended for developers who are designing with Renesas products. You are solely responsible for (1) selecting the appropriate products for your application, (2) designing, validating, and testing your application, and (3) ensuring your application meets applicable standards, and any other safety, security, or other requirements. These resources are subject to change without notice. Renesas grants you permission to use these resources only to develop an application that uses Renesas products. Other reproduction or use of these resources is strictly prohibited. No license is granted to any other Renesas intellectual property or to any third-party intellectual property. Renesas disclaims responsibility for, and you will fully indemnify Renesas and its representatives against, any claims, damages, costs, losses, or liabilities arising from your use of these resources. Renesas' products are provided only subject to Renesas' Terms and Conditions of Sale or other applicable terms agreed to in writing. No use of any Renesas resources expands or otherwise alters any applicable warranties or warranty disclaimers for these products.

(Disclaimer Rev.1.01 Jan 2024)

### Corporate Headquarters

TOYOSU FORESIA, 3-2-24 Toyosu,  
Koto-ku, Tokyo 135-0061, Japan  
[www.renesas.com](http://www.renesas.com)

### Trademarks



Renesas and the Renesas logo are trademarks of Renesas Electronics Corporation. All trademarks and registered trademarks are the property of their respective owners.

### Contact Information

For further information on a product, technology, the most up-to-date version of a document, or your nearest sales office, please visit [www.renesas.com/contact-us/](http://www.renesas.com/contact-us/).

## Looking for pricing, stock, or lifecycle information?

Click below to explore more details on WIN SOURCE:

-  [View 87973DYI-147LFT on WIN SOURCE](#)
-  [Renesas Electronics America](#) Information

## Optimize Your Supply Chain with WIN SOURCE Solutions

-  Global Sourcing Solution
-  Obsolete Management
-  Cost Control Management
-  Shortage Management
-  Alternative Solution
-  Excess Inventory Management