



**THE DATASHEET OF
SMA6852MZ LF2452**



High Voltage 3-Phase Motor Drivers

Features and Benefits

- Built-in pre-drive IC
- MOSFET power element
- CMOS compatible input (3.3 to 5 V)
- High-side gate driver using bootstrap circuit or floating power supply
- Built-in protection circuit for controlling power supply voltage drop
- Built-in overtemperature detection circuit (TD)
- Output of fault signal during operation of protection circuits
- Output current 1.5, 2, and 2.5 A
- Small SIP (SMA 24-pin)

Packages: Power SIP

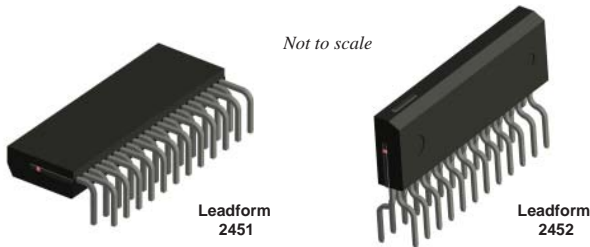

Description

The SMA6850MX/MZ inverter power module (IPM) series provides a robust, highly-integrated solution for optimally controlling 3-phase motor power inverter systems and variable speed control systems used in energy-conserving designs to drive motors of residential and commercial appliances. These ICs take 230 VAC input voltage, and up to 2.5 A (continuous) output current. They can withstand voltages of up to 500 V (MOSFET breakdown voltage).

The SMA6850MX/MZ power package includes an IC with all of the necessary power elements (six MOSFETs) and pre-driver ICs (two), needed to configure the main circuit of an inverter. This enables the main circuit of the inverter to be configured with fewer external components than traditional designs.

Applications include residential white goods (home applications) and commercial appliance motor control:

- Air conditioner fan
- Small ventilation fan
- Dishwasher pump

Functional Block Diagram

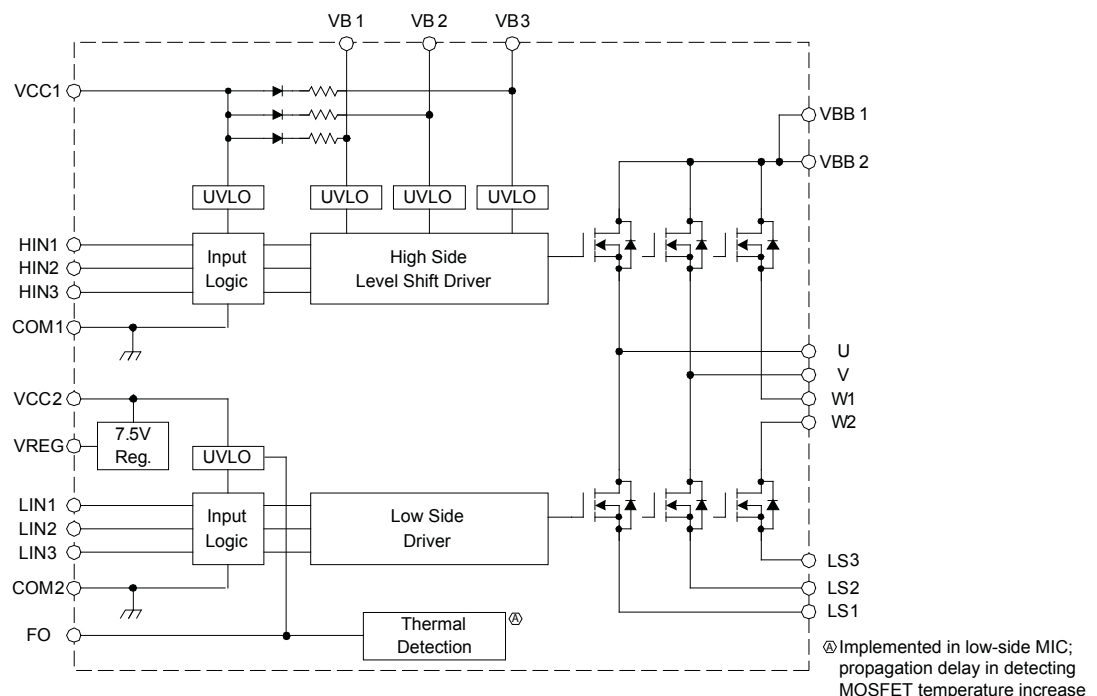

Figure 1. Driver block diagram

Selection Guide

Part Number	Packing	MOSFET Breakdown Voltage, $V_{DSS}(\text{min})$ (V)	Output Current	
			Continuous, $I_O(\text{max})$ (A)	Pulsed, $I_{OP}(\text{max})$ (A)
SMA6852MZ	18 pieces per tube	500	1.5	2.25
SMA6853MX	18 pieces per tube	500	2.5	3.75
SMA6854MZ	18 pieces per tube	600	1.5	2.25

Absolute Maximum Ratings, valid at $T_A = 25^\circ\text{C}$

Characteristic	Symbol	Remarks	Rating	Unit	
MOSFET Breakdown Voltage	V_{DSS}	SMA6852MZ	$V_{CC} = 15\text{ V}$, $I_D = 100\ \mu\text{A}$, $V_{IN} = 0\text{ V}$	500	V
		SMA6853MX		500	V
		SMA6854MZ		600	V
Logic Supply Voltage	V_{CC}	Between VCC and COM	20	V	
Bootstrap Voltage	V_{BS}	Between VB and HS (U,V, and W phases)	20	V	
Output Current, Continuous	I_O	SMA6852MZ		1.5	A
		SMA6853MX		2.5	A
		SMA6854MZ		1.5	A
Output Current, Pulsed	I_{OP}	SMA6852MZ	$PW \leq 100\ \mu\text{s}$, duty cycle = 1%	2.25	A
		SMA6853MX		3.75	A
		SMA6854MZ		2.25	A
Input Voltage	V_{IN}		-0.5 to 7	V	
Allowable Power Dissipation	P_D	$T_C = 25^\circ\text{C}$	28	W	
Thermal Resistance (Junction to Case)	$R_{\theta JC}$	All elements operating	4.46	$^\circ\text{C/W}$	
Thermal Resistance (Junction to Ambient)	$R_{\theta JA}$	All elements operating	31.25	$^\circ\text{C/W}$	
Case Operating Temperature	T_{COP}		-20 to 100	$^\circ\text{C}$	
Junction Temperature (MOSFET)	T_J		150	$^\circ\text{C}$	
Storage Temperature	T_{stg}		-40 to 150	$^\circ\text{C}$	

Recommended Operating Conditions

Characteristic	Symbol	Remarks	Min.	Typ.	Max.	Units	
Main Supply Voltage	V_{BB}	SMA6852MZ	Between V_{BB} and LS	-	280	400	V
		SMA6853MX		-	-	400	V
		SMA6854MZ		-	300	450	V
Logic Supply Voltage	V_{CC}	Between VCC and COM	13.5	-	16.5	V	
Minimum Input Pulse	$T_W(\text{min})$		0.5	-	-	μs	
Dead Time	t_{dead}		1.5	-	-	μs	

All performance characteristics given are typical values for circuit or system baseline design only and are at the nominal operating voltage and an ambient temperature, T_A , of 25°C , unless otherwise stated.

Typical Application Diagram

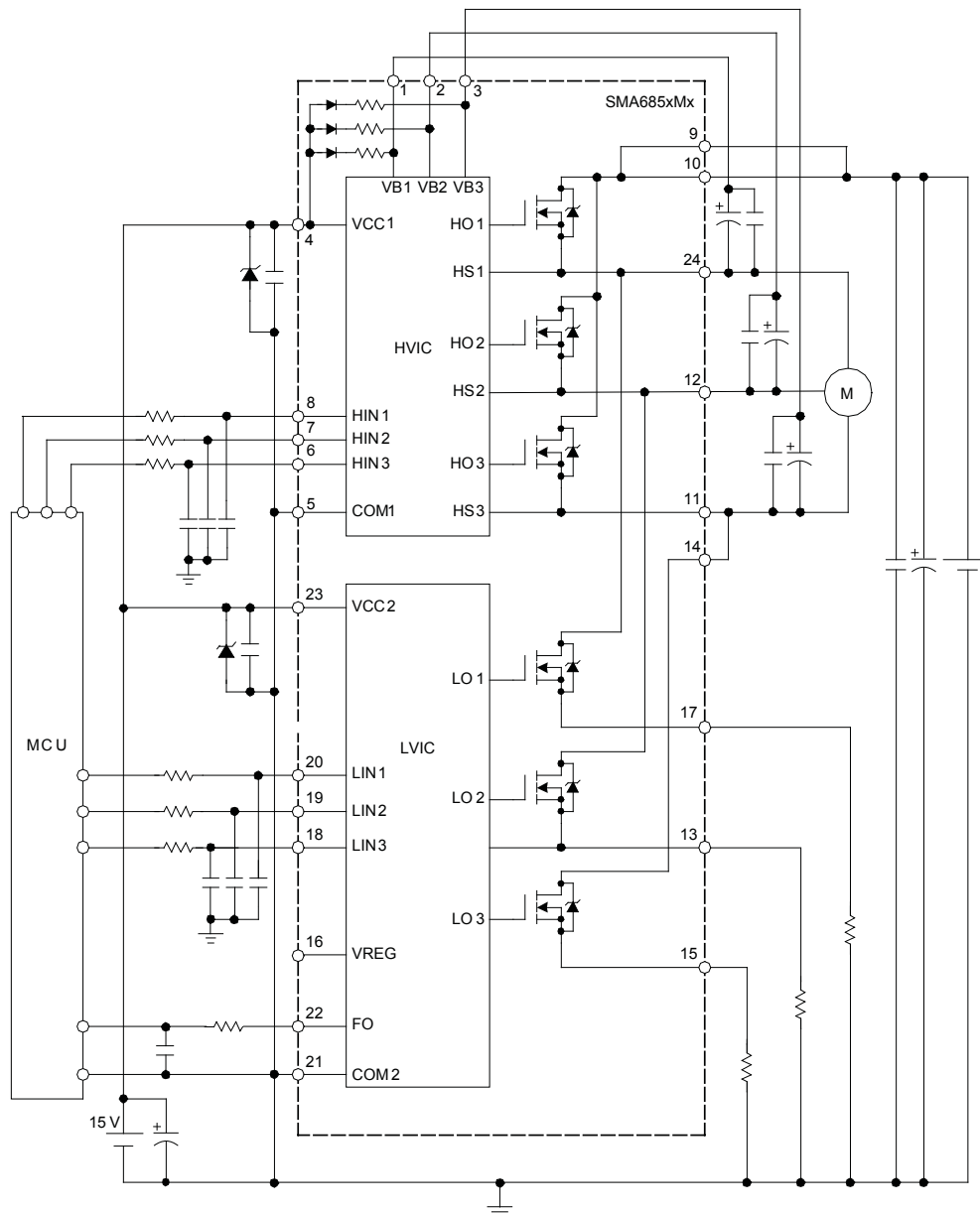

NOTE:

- All of the input pins are connected to GND with internal pull-down resistors rated at 100 kΩ, however, an external pull-down resistor may be required to secure stable condition of the inputs if high impedance conditions are applied to them.
- The external electrolytic capacitors should be placed as close to the IC as possible, in order to avoid malfunctions from external noise interference. Put a ceramic capacitor in parallel with the electrolytic capacitor if further reduction of noise susceptibility is necessary.
- This IPM does not have an overcurrent detection feature. It is recommended to implement the feature externally. When an overcurrent condition occurs, the application MCU must stop driving the IPM within 2 μs.
- Snubber capacitors should be surge suppressor film capacitors with sufficient rating to suppress surge voltages. To determine the capacitance for an application, please verify the surge voltage in the actual application.

ELECTRICAL CHARACTERISTICS, valid at $T_A=25^{\circ}\text{C}$, unless otherwise noted

Characteristics	Symbol	Conditions	Min	Typ	Max	Units	
Logic Supply Voltage	V_{CC}	Between VCC and COM	13.5	15	16.5	V	
Logic Supply Current	I_{CC}	SMA6852MZ	$V_{CC} = 15\text{ V}$, $I_{REG} = 0\text{ A}$	-	4	6	mA
		SMA6853MX		-	2.5	4.0	mA
		SMA6854MZ		-	3.8	-	mA
Input Voltage	V_{IH}	$V_{CC} = 15\text{ V}$, output on	-	2.0	2.5	V	
	V_{IL}	$V_{CC} = 15\text{ V}$, output off	1.0	1.5	-	V	
Input Voltage Hysteresis	V_{Ihys}	$V_{CC} = 15\text{ V}$	-	0.5	-	V	
Input Current	I_{IH}	High side, $V_{CC} = 15\text{ V}$, $V_{IN} = 5\text{ V}$	-	50	100	μA	
	I_{IL}	Low side, $V_{CC} = 15\text{ V}$, $V_{IN} = 0\text{ V}$	-	-	2	μA	
Undervoltage Lock Out	V_{UVHL}	High side, between VB and U, V, or W	9.0	10.0	11.0	V	
	V_{UVHH}		9.5	10.5	11.5	V	
	V_{UVHhys}	High side, hysteresis	-	0.5	-	V	
	V_{UVLL}	Low side, between VCC and COM	10.0	11.0	12.0	V	
	V_{UVLH}		10.5	11.5	12.5	V	
	V_{UVLhys}	Low side, hysteresis	-	0.5	-	V	
FO Terminal Output Voltage	V_{FOL}	$V_{CC} = 15\text{ V}$	0	-	1.0	V	
	V_{FOH}		4.0	-	5.5	V	
Overtemperature Detection Threshold Temperature (activation and deactivation)	T_{DH}	$V_{CC} = 15\text{ V}$, no heatsink	135	150	165	$^{\circ}\text{C}$	
	T_{DL}		105	120	135	$^{\circ}\text{C}$	
	T_{Dhys}		-	30	-	$^{\circ}\text{C}$	
Output Voltage for Regulator	V_{REG}	$I_{REG} = 35\text{ mA}$, $T_C = -20^{\circ}\text{C}$ to 100°C	6.75	7.5	8.25	V	
Bootstrap Diode Leakage Current	I_{LBD}	$V_R = 500\text{ V}$	-	-	10	μA	
Bootstrap Diode Forward Voltage	V_{FBD}	$I_F = 0.15\text{ A}$	-	1.1	1.3	V	
Bootstrap Diode Series Resistor	R_{BD}	SMA6852MZ	17.6	22	26.4	Ω	
		SMA6853MX	17.6	22	26.4	Ω	
		SMA6854MZ	48	60	72	Ω	
MOSFET Breakdown Voltage	V_{DSS}	SMA6852MZ	$V_{CC} = 15\text{ V}$, $I_D = 100\text{ }\mu\text{A}$, $V_{IN} = 0\text{ V}$	500	-	-	V
		SMA6853MX		500	-	-	V
		SMA6854MZ		600	-	-	V
MOSFET Leakage Current	I_{DSS}	$V_{CC} = 15\text{ V}$, $V_{DS} = 500\text{ V}$, $V_{IN} = 0\text{ V}$	-	-	100	μA	
MOSFET On State Resistance	$R_{DS(on)}$	SMA6852MZ	$V_{CC} = 15\text{ V}$, $I_D = 0.75\text{ A}$, $V_{IN} = 5\text{ V}$	-	3.6	4.0	Ω
		SMA6853MX	$V_{CC} = 15\text{ V}$, $I_D = 1.25\text{ A}$, $V_{IN} = 5\text{ V}$	-	2.0	2.4	Ω
		SMA6854MZ	$V_{CC} = 15\text{ V}$, $I_D = 1.25\text{ A}$, $V_{IN} = 5\text{ V}$	-	3.0	3.5	Ω
MOSFET Diode Forward Voltage	V_{SD}	SMA6852MZ	$V_{CC} = 15\text{ V}$, $I_{SD} = 0.75\text{ A}$, $V_{IN} = 0\text{ V}$	-	1.1	1.5	V
		SMA6853MX	$V_{CC} = 15\text{ V}$, $I_{SD} = 1.25\text{ A}$, $V_{IN} = 0\text{ V}$	-	1.1	1.5	V
		SMA6854MZ	$V_{CC} = 15\text{ V}$, $I_{SD} = 1.25\text{ A}$, $V_{IN} = 0\text{ V}$	-	1.0	1.5	V

SMA6852MZ SWITCHING CHARACTERISTICS, valid at $T_A=25^\circ\text{C}$, unless otherwise noted

Characteristics	Symbol	Conditions	Min	Typ	Max	Units
Switching Time, High Side	$t_{dH(on)}$	$V_{BB} = 300\text{ V}, V_{CC} = 15\text{ V}, I_D = 1.5\text{ A}, 0\text{ V} \leq V_{IN} \leq 5\text{ V}$	–	530	–	ns
	t_{rH}		–	95	–	ns
	t_{rr}		–	130	–	ns
	$t_{dH(off)}$		–	385	–	ns
	t_{fH}		–	40	–	ns
Switching Time, Low Side	$t_{dL(on)}$	$V_{BB} = 300\text{ V}, V_{CC} = 15\text{ V}, I_D = 1.5\text{ A}, 0\text{ V} \leq V_{IN} \leq 5\text{ V}$	–	530	–	ns
	t_{rL}		–	95	–	ns
	t_{rr}		–	120	–	ns
	$t_{dL(off)}$		–	445	–	ns
	t_{fL}		–	30	–	ns

SMA6853MX SWITCHING CHARACTERISTICS, valid at $T_A=25^\circ\text{C}$, unless otherwise noted

Characteristics	Symbol	Conditions	Min	Typ	Max	Units
Switching Time, High Side	$t_{dH(on)}$	$V_{BB} = 300\text{ V}, V_{CC} = 15\text{ V}, I_D = 2.5\text{ A}, 0\text{ V} \leq V_{IN} \leq 5\text{ V}$	–	650	–	ns
	t_{rH}		–	100	–	ns
	t_{rr}		–	150	–	ns
	$t_{dH(off)}$		–	520	–	ns
	t_{fH}		–	50	–	ns
Switching Time, Low Side	$t_{dL(on)}$	$V_{BB} = 300\text{ V}, V_{CC} = 15\text{ V}, I_D = 2.5\text{ A}, 0\text{ V} \leq V_{IN} \leq 5\text{ V}$	–	700	–	ns
	t_{rL}		–	100	–	ns
	t_{rr}		–	150	–	ns
	$t_{dL(off)}$		–	580	–	ns
	t_{fL}		–	40	–	ns

SMA6854MZ SWITCHING CHARACTERISTICS, valid at $T_A=25^\circ\text{C}$, unless otherwise noted

Characteristics	Symbol	Conditions	Min	Typ	Max	Units
Switching Time, High Side	$t_{dH(on)}$	$V_{BB} = 150\text{ V}, V_{CC} = 15\text{ V}, I_D = 2\text{ A}, 0\text{ V} \leq V_{IN} \leq 5\text{ V}$	–	530	–	ns
	t_{rH}		–	55	–	ns
	t_{rr}		–	125	–	ns
	$t_{dH(off)}$		–	510	–	ns
	t_{fH}		–	50	–	ns
Switching Time, Low Side	$t_{dL(on)}$	$V_{BB} = 150\text{ V}, V_{CC} = 15\text{ V}, I_D = 2\text{ A}, 0\text{ V} \leq V_{IN} \leq 5\text{ V}$	–	530	–	ns
	t_{rL}		–	60	–	ns
	t_{rr}		–	125	–	ns
	$t_{dL(off)}$		–	540	–	ns
	t_{fL}		–	55	–	ns

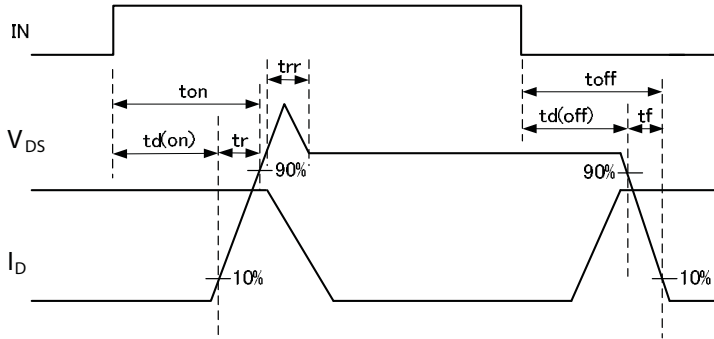

Switching Characteristics Definitions

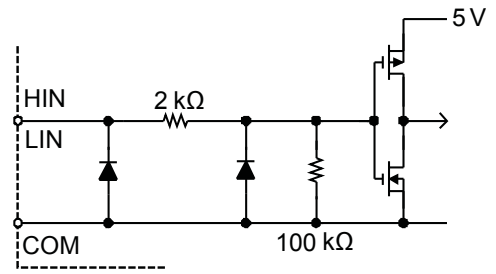

HINx and LINx Terminals Internal Equivalent Circuit

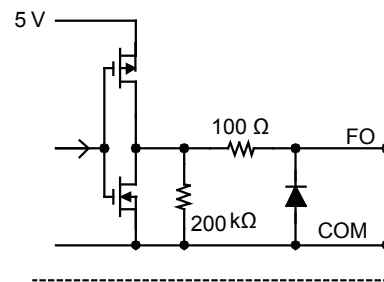

FO Terminal Internal Equivalent Circuit

Truth Table

Mode	Hin	Lin	H-side MOSFET	L-side MOSFET
Normal	L	L	Off	Off
	H	L	On	Off
	L	H	Off	On
	H	H	On	On
Thermal Detection (TD) ¹	L	L	Off	Off
	H	L	On	Off
	L	H	Off	On
	H	H	On	On
UVLO (VCC) ²	L	L	Off	Off
	H	L	Off	Off
	L	H	Off	Off
	H	H	Off	Off
UVLO (VB) ³	L	L	Off	Off
	H	L	Off	Off
	L	H	Off	On
	H	H	Off	On

¹The Thermal Detection function drives the FO pin output to logic high. The external microcontroller should detect this condition.

²Returning to the Normal mode of operation from a V_{CC} UVLO condition, a low-side MOSFET resumes switching on the first logic high of a LINx input.

³Returning to the Normal mode of operation from a V_B UVLO condition, a high-side MOSFET resumes switching on the rising edge of an HINx input.

Note: To prevent a shoot-through condition, the external microcontroller should not drive HINx = LINx = H at the same time.

High Side Driver Input/Output Timing Diagrams

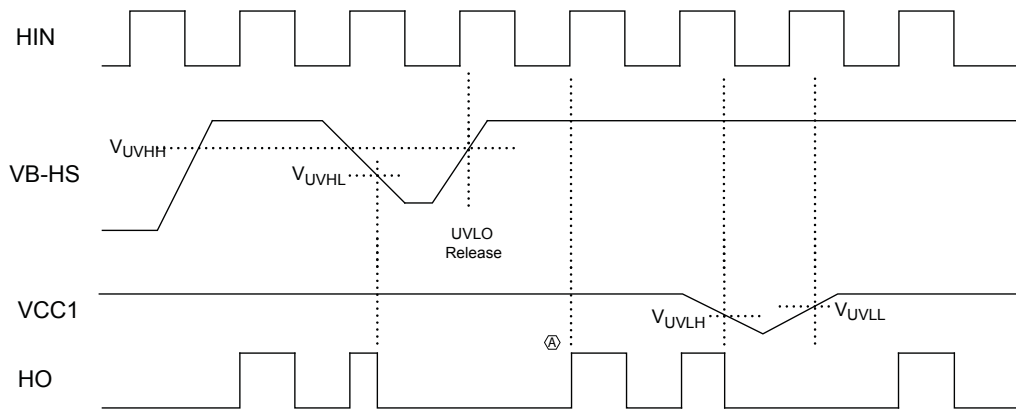

Ⓐ After a high-side UVLO is released, HO output is activated at the rising edge of HIN. High-side UVLO conditions are not reflected in the FO pin output.

Low Side Driver Input/Output Timing Diagrams

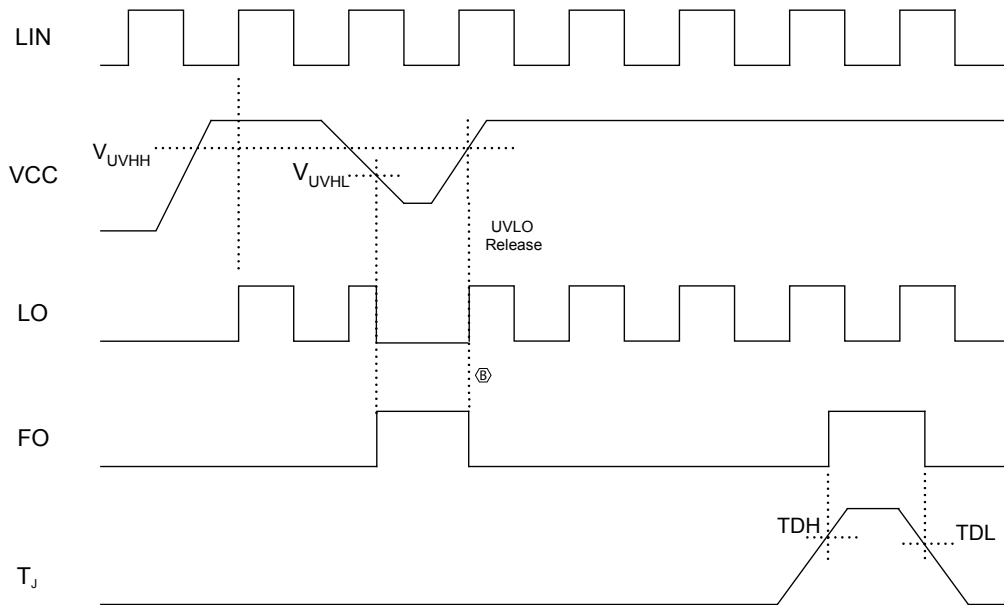

Ⓑ After a low-side UVLO is released, LO output is activated at the logic high of an LINx input. Low-side UVLO conditions drive the FO pin to logic high.

Pin-out Diagrams

Leadform 2451

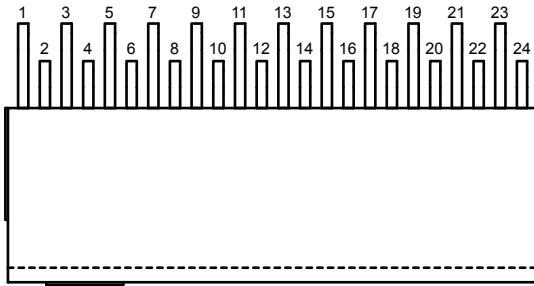

Chamfer on Opposite Side

Leadform 2452

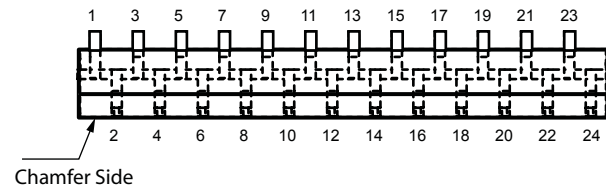

Terminal List Table

Number	Name	Function
1	VB1	High side bootstrap terminal (U phase)
2	VB2	High side bootstrap terminal (V phase)
3	VB3	High side bootstrap terminal (W phase)
4	VCC1	High side logic supply voltage
5	COM1	High side logic GND terminal
6	HIN3	High side input terminal (W phase)
7	HIN2	High side input terminal (V phase)
8	HIN1	High side input terminal (U phase)
9	VBB1	Main supply voltage 1 (connect to VBB2 externally)
10	VBB2	Main supply voltage 2 (connect to VBB1 externally)
11	W1	Output of W phase (connect to W2 externally)
12	V	Output of V phase
13	LS2	Source terminal of V phase
14	W2	Output of W phase (connect to W1 externally)
15	LS3	Source terminal of W phase
16	VREG	Internal regulator output terminal
17	LS1	Source terminal of U phase
18	LIN3	Low side input terminal (W phase)
19	LIN2	Low side input terminal (V phase)
20	LIN1	Low side input terminal (U phase)
21	COM2	Low side GND terminal
22	FO	Overtemperature detection fault-signal output terminal
23	VCC2	Low side logic supply voltage
24	U	Output of U phase

Because reliability can be affected adversely by improper storage environments and handling methods, please observe the following cautions.

Cautions for Storage

- Ensure that storage conditions comply with the standard temperature (5°C to 35°C) and the standard relative humidity (around 40 to 75%); avoid storage locations that experience extreme changes in temperature or humidity.
- Avoid locations where dust or harmful gases are present and avoid direct sunlight.
- Reinspect for rust on leads and solderability of products that have been stored for a long time.

Cautions for Testing and Handling

When tests are carried out during inspection testing and other standard test periods, protect the products from power surges from the testing device, shorts between adjacent products, and shorts to the heatsink.

Remarks About Using Silicone Grease with a Heatsink

- When silicone grease is used in mounting this product on a heatsink, it shall be applied evenly and thinly. If more silicone grease than required is applied, it may produce stress.
- Volatile-type silicone greases may permeate the product and produce cracks after long periods of time, resulting in reduced heat radiation effect, and possibly shortening the lifetime of the product.
- Our recommended silicone greases for heat radiation purposes, which will not cause any adverse effect on the product life, are indicated below:

Type	Suppliers
G746	Shin-Etsu Chemical Co., Ltd.
YG6260	Momentive Performance Materials
SC102	Dow Corning Toray Silicone Co., Ltd.

Soldering

- When soldering the products, please be sure to minimize the working time, within the following limits:
260±5°C 10 s
380±5°C 5 s
- Soldering iron should be at a distance of at least 1.5 mm from the body of the products

Electrostatic Discharge

- When handling the products, operator must be grounded. Grounded wrist straps worn should have at least 1 MΩ of resistance to ground to prevent shock hazard.
- Workbenches where the products are handled should be grounded and be provided with conductive table and floor mats.
- When using measuring equipment such as a curve tracer, the equipment should be grounded.
- When soldering the products, the head of soldering irons or the solder bath must be grounded in order to prevent leak voltages generated by them from being applied to the products.
- The products should always be stored and transported in our shipping containers or conductive containers, or be wrapped in aluminum foil.

- The contents in this document are subject to changes, for improvement and other purposes, without notice. Make sure that this is the latest revision of the document before use.
- Application and operation examples described in this document are quoted for the sole purpose of reference for the use of the products herein and Sanken can assume no responsibility for any infringement of industrial property rights, intellectual property rights or any other rights of Sanken or any third party which may result from its use.
- Although Sanken undertakes to enhance the quality and reliability of its products, the occurrence of failure and defect of semiconductor products at a certain rate is inevitable. Users of Sanken products are requested to take, at their own risk, preventative measures including safety design of the equipment or systems against any possible injury, death, fires or damages to the society due to device failure or malfunction.
- Sanken products listed in this document are designed and intended for the use as components in general purpose electronic equipment or apparatus (home appliances, office equipment, telecommunication equipment, measuring equipment, etc.).
When considering the use of Sanken products in the applications where higher reliability is required (transportation equipment and its control systems, traffic signal control systems or equipment, fire/crime alarm systems, various safety devices, etc.), and whenever long life expectancy is required even in general purpose electronic equipment or apparatus, please contact your nearest Sanken sales representative to discuss, prior to the use of the products herein.
The use of Sanken products without the written consent of Sanken in the applications where extremely high reliability is required (aerospace equipment, nuclear power control systems, life support systems, etc.) is strictly prohibited.
- In the case that you use our semiconductor devices or design your products by using our semiconductor devices, the reliability largely depends on the degree of derating to be made to the rated values. Derating may be interpreted as a case that an operation range is set by derating the load from each rated value or surge voltage or noise is considered for derating in order to assure or improve the reliability. In general, derating factors include electric stresses such as electric voltage, electric current, electric power etc., environmental stresses such as ambient temperature, humidity etc. and thermal stress caused due to self-heating of semiconductor devices. For these stresses, instantaneous values, maximum values and minimum values must be taken into consideration.
In addition, it should be noted that since power devices or IC's including power devices have large self-heating value, the degree of derating of junction temperature (T_j) affects the reliability significantly.
- When using the products specified herein by either (i) combining other products or materials therewith or (ii) physically, chemically or otherwise processing or treating the products, please duly consider all possible risks that may result from all such uses in advance and proceed therewith at your own responsibility.
- Anti radioactive ray design is not considered for the products listed herein.
- Sanken assumes no responsibility for any troubles, such as dropping products caused during transportation out of Sanken's distribution network.
- The contents in this document must not be transcribed or copied without Sanken's written consent.

Looking for pricing, stock, or lifecycle information?

Click below to explore more details on WIN SOURCE:

 [View SMA6852MZ LF2452 on WIN SOURCE](#)

 [Sanken Information](#)

Optimize Your Supply Chain with WIN SOURCE Solutions

-  Global Sourcing Solution
-  Obsolete Management
-  Cost Control Management
-  Shortage Management
-  Alternative Solution
-  Excess Inventory Management