



**THE DATASHEET OF
SIT9002AC-232N33DO50.00000**



Features

- World's first differential spread spectrum oscillator
- Extremely low cycle-cycle jitter
 - As low as 10 ps (typical)
- Wide frequency range
 - 1 MHz to 220 MHz
 - 220 MHz to 800 MHz (contact SiTime)
- Eight spread selections (31.5 KHz modulation rate)
 - Center Spread: $\pm 0.25\%$, $\pm 0.5\%$, $\pm 1.0\%$, $\pm 2.0\%$
 - Down Spread: -0.5% , -1.0% , -2.0% , -4.0%
 - For -0.25% and $\pm 0.125\%$ contact SiTime
- Low frequency stability (Spread = OFF)
 - ± 25 ppm or ± 50 ppm
- Operating voltage
 - 1.8V or 2.5 or 3.3 V
- Operating temperature range:
 - Industrial, -40°C to 85°C
 - Extended Commercial, -20°C to 70°C
- Small footprint
 - $5.0 \times 3.2 \times 0.75$ mm
 - $7.0 \times 5.0 \times 0.90$ mm
- Pb-free and RoHS compliant
- Ultra-reliable start up and greater immunity from interference

Benefits

- Services most PC peripherals, networking, and consumer applications
- Provides wide range of spread percentage for maximum electromagnetic interference (EMI) reduction
- Up to -17 dB reduction on third harmonic and -12dB on the fundamental
- Fast time to market due to not needing to redesign the PCB for EMI reduction
- Factory programmable for ultra-fast lead time
- No crystal or load capacitors required
- Eliminates crystal qualification time
- 50%+ board saving space
- Completely quartz-free

Applications

- PCI-Express
- USB 3.0
- Fully Buffered DIMM
- Blade Server
- Router
- System Clock
- Networking and Computing
- Automotive
- Industrial

Block Diagram

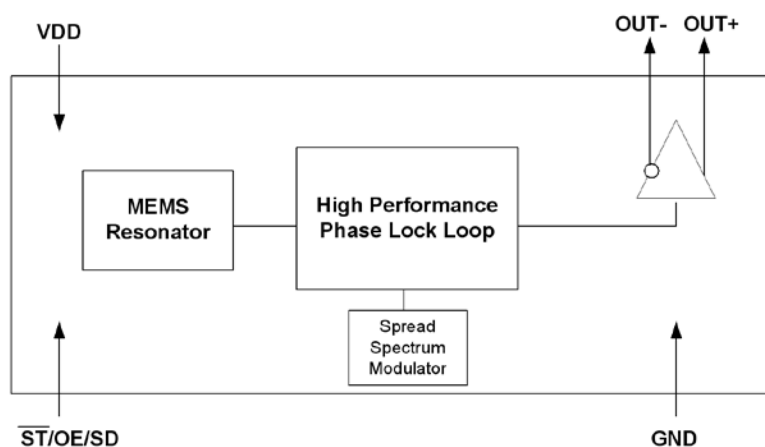

Pinout

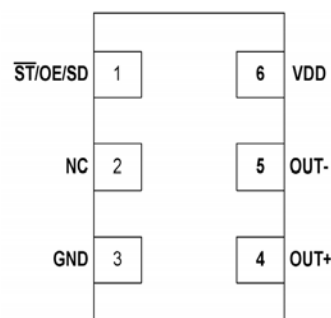

Pin Description

Pin No.	Name		Pin Description
1	ST/OE/SD	Input	Standby or Output Enable pin for OUT+ and OUT-. OE: When High or Open : OUT+ and OUT- = active When Low : OUT+ and OUT- = High Impedance state ST: When High or Open : OUT+ and OUT- = active When Low : OUT+ and OUT- = Output is low (weak pull down), oscillation stops SD: Spread Disable - disables spread spectrum When High or Open : Spread Spectrum modulation = active When Low : Spread Spectrum modulation = Off
2	NC	NA	No connect pin, leave it floating.
3	GND	Power	VDD power supply ground. Connect to ground
4	OUT+	Output	1 to 220 MHz programmable clock output. For frequencies > 220 MHz contact SiTime
5	OUT-	Output	
6	VDD	Power	Power supply

Absolute Maximum Ratings

Attempted operation outside the absolute maximum ratings of the part may cause permanent damage to the part. Actual performance of the IC is only guaranteed within the operational specifications, not absolute maximum ratings.

Absolute Maximum Table

Parameter	Min.	Max.	Unit
Storage Temperature	-65	150	°C
VDD	-0.5	4	V
Vin	GND - 0.5	VDD + 0.5	V
Theta JA (with copper plane on VDD and GND) 5.0 x 3.2 package	–	68	°C/W
7.0 x 5.0 package when center pad is soldered down	–	38	°C/W
7.0 x 5.0 package when center pad is not soldered down	–	90	°C/W
Theta JC (with PCB traces of 0.010 inch to all pins) 5.0 x 3.2 package	–	45	°C/W
7.0 x 5.0 package when center pad is soldered down	–	35	°C/W
7.0 x 5.0 package when center pad is not soldered down	–	48	°C/W
Soldering Temperature (follow standard Pb free soldering guidelines)	–	260	°C
Number of Program Writes	–	1	NA
Program Retention over -40 to 125C, Process, VDD (0 to 3.6V)	–	1,000+	years
Human Body Model (JESD22-A114)	2000	–	V
Charged Device Model (JESD22-C101)	750	–	–
Machine Model (JESD22-A115)	200	–	–

DC Electrical Specifications

Environmental Compliance

Parameter	Condition/Test Method
Mechanical Shock	MIL-STD-883F, Method 2002
Mechanical Vibration	MIL-STD-883F, Method 2007
Temperature Cycle	MIL-STD-883F, Method 1010-65-150°C (1000 cycle)
Solderability	MIL-STD-883F, Method 2003
Moisture Sensitivity Level	MSL1 @ 260°C

LVC MOS input, OE or \overline{ST} pin, $3.3V \pm 10\%$ or $2.5V \pm 10\%$ or $1.8V \pm 5\%$, -40 to 85°C

Symbol	Parameter	Condition	Min.	Typ.	Max.	Unit
V_{IH}	Input High Voltage		70	–	–	%Vdd
V_{IL}	Input Low Voltage		–	–	30	%Vdd
I_{IH}	Input High Current	OE or ST or SD pin	–	–	10	μA
I_{IL}	Input Low Current	OE or ST or SD pin	-10	–	–	μA
T_{pu}	Power Up Time	Time from minimum power supply voltage to the first cycle (Guaranteed no runt pulses)	–	–	10	ms

LVPECL, $3.3V \pm 10\%$ or $2.5V \pm 10\%$, -40 to 85°C

Symbol	Parameter	Condition	Min.	Typ.	Max.	Unit
V_{DD}	Supply Voltage		2.97	3.3	3.63	V
			2.25	2.5	2.75	V
I_{DD}	Supply Current	$V_{DD} = 3.3$, Excluding Load Termination Current	–	75	84	mA
		$V_{DD} = 2.5$, Excluding Load Termination Current	–	75	84	mA
V_{OH}	Output High Voltage	50 Ohm termination to $V_{DD} - 2.0V$ See Figure 2,3.	$V_{DD}-1.1$	–	$V_{DD}-0.7$	V
V_{OL}	Output Low Voltage		$V_{DD}-2.0$	–	$V_{DD}-1.4$	V
V_{swing}	Pk-Pk Output Voltage Swing		600	800	1000	mV

HCSL, $3.3V \pm 10\%$ or $2.5V \pm 10\%$, -40 to 85°C

Symbol	Parameter	Condition	Min.	Typ.	Max.	Unit
V_{DD}	Supply Voltage		2.97	3.3	3.63	V
			2.25	2.5	2.75	V
I_{DD}	Supply Current	$V_{DD} = 3.3$, Excluding Load Termination Current	–	73	80	mA
		$V_{DD} = 2.5$, Excluding Load Termination Current	–	73	80	mA
V_{OH}	Output High Voltage	50 Ohm termination to GND See Figure 4.	0.6	0.75	0.95	V
V_{OL}	Output Low Voltage		0.0	–	50	mV
V_{swing}	Pk-Pk Output Voltage Swing		600	750	950	mV

LVDS, $3.3V \pm 10\%$ or $2.5V \pm 10\%$, -40 to 85°C

Symbol	Parameter	Condition	Min.	Typ.	Max.	Unit
V_{DD}	Supply Voltage		2.97	3.3	3.63	V
			2.25	2.5	2.75	V
I_{DD}	Supply Current	$V_{DD} = 3.3$, Excluding Load Termination Current	–	75	85	mA
		$V_{DD} = 2.5$, Excluding Load Termination Current	–	70	77	mA
V_{OD1}	Differential Output Voltage	Swing Mode = Normal Single load termination. See Figure 5.	250	350	450	mV
ΔV_{OD1}	V_{OD} Magnitude Change		–	–	50	mV
V_{OS1}	Offset Voltage		–	1.2	–	V
ΔV_{OS1}	V_{OS} Magnitude Change		–	–	50	mV
V_{OD2}	Differential Output Voltage	Swing Mode = High Single load termination. See Figure 5.	500	700	900	mV
ΔV_{OD2}	V_{OD} Magnitude Change		–	–	50	mV
V_{OS2}	Offset Voltage		–	1.2	–	V
ΔV_{OS2}	V_{OS} Magnitude Change		–	–	50	mV
V_{OD3}	Differential Output Voltage	Swing Mode = High Double load termination. See Figure 6.	250	350	450	mV
ΔV_{OD3}	V_{OD} Magnitude Change		–	–	50	mV
V_{OS3}	Offset Voltage		–	1.2	–	V
ΔV_{OS3}	V_{OS} Magnitude Change		–	–	50	mV

CML, 3.3V ± 10% or 2.5V ± 10% or 1.8V ± 5%, -40 to 85°C

Symbol	Parameter	Condition	Min.	Typ.	Max.	Unit	
V _{DD}	Supply Voltage		2.97	3.3	3.63	V	
			2.25	2.5	2.75	V	
			1.71	1.8	1.89	V	
I _{DD}	Supply Current	V _{DD} = 3.3V	Excluding Load Termination Current	–	48	51	mA
		V _{DD} = 2.5V		–	48	51	mA
		V _{DD} = 1.8V		–	48	51	mA
V _{OH1}	Output High Voltage	Swing Mode = Normal Single Load Termination See Figure 7.	V _{DD} -0.1	–	V _{DD}	V	
V _{OL1}	Output Low Voltage		V _{DD} -0.55	V _{DD} -0.425	V _{DD} -0.3	V	
V _{swing1}	Pk-Pk Output Voltage Swing		300	425	550	mV	
V _{OH2}	Output High Voltage	Swing Mode = High Single Load Termination See Figure 7.	V _{DD} -0.1	–	V _{DD}	V	
V _{OL2}	Output Low Voltage		V _{DD} -1.1	V _{DD} -0.85	V _{DD} -0.6	V	
V _{swing2}	Pk-Pk Output Voltage Swing		600	850	1100	mV	
V _{OH3}	Output High Voltage	Swing Mode = High Double Load Termination See Figure 8.	V _{DD} -0.1	–	V _{DD}	V	
V _{OL3}	Output Low Voltage		V _{DD} -0.55	V _{DD} -0.425	V _{DD} -0.3	V	
V _{swing3}	Pk-Pk Output Voltage Swing		300	425	550	mV	

AC Electrical Specifications

LVPECL, 3.3V ± 10%, -40 to 85°C

Symbol	Parameter	Condition	Min.	Typ.	Max.	Unit	
F _{out}	Output Frequency		1.0	–	220	MHz	
F _{stab}	Frequency Stability	Inclusive of initial stability, operating temp., rated power supply voltage change, load change	-20 to 70°C	-25	–	+25	ppm
			-40 to 85°C	-50	–	+50	ppm
F _{age}	Aging	First year @ 25°C	–	–	1	PPM	
DC	Duty Cycle		45	–	55	%	
t _R /t _F	Output Rise/Fall Time	20% to 80%	100	150	300	ps	
T _{CCJ}	Cycle-Cycle Jitter	F _{out} = 100 MHz, -0.5% down spread	–	10	16	ps	
		F _{out} = 150 MHz, -0.5% down spread	–	8	14	ps	
		F _{out} = 200 MHz, -0.5% down spread	–	8	14	ps	

LVPECL, 2.5V ± 10%, -40 to 85°C

Symbol	Parameter	Condition	Min.	Typ.	Max.	Unit	
F _{out}	Output Frequency		1.0	–	220	MHz	
F _{stab}	Frequency Stability	Inclusive of initial stability, operating temp., rated power supply voltage change, load change	-20 to 70°C	-25	–	+25	ppm
			-40 to 85°C	-50	–	+50	ppm
F _{age}	Aging	First year @ 25°C	–	–	1	PPM	
DC	Duty Cycle		45	–	55	%	
t _R /t _F	Output Rise/Fall Time	20% to 80%	100	150	300	ps	
T _{CCJ}	Cycle-Cycle Jitter	F _{out} = 100 MHz, -0.5% down spread	–	10	16	ps	
		F _{out} = 150 MHz, -0.5% down spread	–	8	14	ps	
		F _{out} = 200 MHz, -0.5% down spread	–	8	14	ps	

HCSL, 3.3V ± 10%, -40 to 85°C

Symbol	Parameter	Condition	Min.	Typ.	Max.	Unit	
F _{out}	Output Frequency		1.0	–	220	MHz	
F _{stab}	Frequency Stability	Inclusive of initial stability, operating temp., rated power supply voltage change, load change	-20 to 70°C	-25	–	+25	ppm
			-40 to 85°C	-50	–	+50	ppm
F _{age}	Aging	First year @ 25°C	–	–	1	PPM	
DC	Duty Cycle		45	–	55	%	
t _R /t _F	Output Rise/Fall Time	20% to 80%	200	280	375	ps	
T _{CCJ}	Cycle-Cycle Jitter	F _{out} = 100 MHz, -0.5% down spread	–	10	16	ps	
		F _{out} = 150 MHz, -0.5% down spread	–	10	15	ps	
		F _{out} = 200 MHz, -0.5% down spread	–	10	15	ps	

HCSL, 2.5V ± 10%, -40 to 85°C

Symbol	Parameter	Condition	Min.	Typ.	Max.	Unit	
F _{out}	Output Frequency		1.0	–	220	MHz	
F _{stab}	Frequency Stability	Inclusive of initial stability, operating temp., rated power supply voltage change, load change	-20 to 70°C	-25	–	+25	ppm
			-40 to 85°C	-50	–	+50	ppm
F _{age}	Aging	First year @ 25°C	–	–	1	PPM	
DC	Duty Cycle		45	–	55	%	
t _R /t _F	Output Rise/Fall Time	20% to 80%	200	300	400	ps	
T _{CCJ}	Cycle-Cycle Jitter	F _{out} = 100 MHz, -0.5% down spread	–	9	19	ps	
		F _{out} = 150 MHz, -0.5% down spread	–	9	17	ps	
		F _{out} = 200 MHz, -0.5% down spread	–	9	15	ps	

LVDS, 3.3V ± 10%, -40 to 85°C

Symbol	Parameter	Condition	Min.	Typ.	Max.	Unit	
F _{out}	Output Frequency		1.0	–	220	MHz	
F _{stab}	Frequency Stability	Inclusive of initial stability, operating temp., rated power supply voltage change, load change	-20 to 70°C	-25	–	+25	ppm
			-40 to 85°C	-50	–	+50	ppm
F _{age}	Aging	First year @ 25°C	–	–	1	PPM	
DC	Duty Cycle		45	–	55	%	
t _R /t _F	Output Rise/Fall Time	20% to 80%	100	200	325	ps	
T _{CCJ}	Cycle-Cycle Jitter	F _{out} = 100 MHz, -0.5% down spread	–	11	19	ps	
		F _{out} = 150 MHz, -0.5% down spread	–	11	20	ps	
		F _{out} = 200 MHz, -0.5% down spread	–	11	21	ps	

LVDS, 2.5V ± 10%, -40 to 85°C

Symbol	Parameter	Condition	Min.	Typ.	Max.	Unit	
F _{out}	Output Frequency		1.0	–	220	MHz	
F _{stab}	Frequency Stability	Inclusive of initial stability, operating temp., rated power supply voltage change, load change	-20 to 70°C	-25	–	+25	ppm
			-40 to 85°C	-50	–	+50	ppm
F _{age}	Aging	First year @ 25°C	–	–	1	PPM	
DC	Duty Cycle		45	–	55	%	
t _R /t _F	Output Rise/Fall Time	20% to 80%	100	260	325	ps	
T _{CCJ}	Cycle-Cycle Jitter	F _{out} = 100 MHz, -0.5% down spread	–	14	26	ps	
		F _{out} = 150 MHz, -0.5% down spread	–	14	26	ps	
		F _{out} = 200 MHz, -0.5% down spread	–	14	27	ps	

CML, 3.3V ± 10%, -40 to 85°C

Symbol	Parameter	Condition	Min.	Typ.	Max.	Unit	
F _{out}	Output Frequency		1.0	–	220	MHz	
F _{stab}	Frequency Stability	Inclusive of initial stability, operating temp., rated power supply voltage change, load change	-20 to 70°C	-25	–	+25	ppm
			-40 to 85°C	-50	–	+50	ppm
F _{age}	Aging	First year @ 25°C	–	–	1	PPM	
DC	Duty Cycle		45	–	55	%	
t _R /t _F	Output Rise/Fall Time	20% to 80%	150	220	300	ps	
T _{CCJ}	Cycle-Cycle Jitter	F _{out} = 100 MHz, -0.5% down spread	–	11	20	ps	
		F _{out} = 150 MHz, -0.5% down spread	–	11	18	ps	
		F _{out} = 200 MHz, -0.5% down spread	–	10	19	ps	

CML, 2.5V ± 10%, -40 to 85°C

Symbol	Parameter	Condition	Min.	Typ.	Max.	Unit	
F _{out}	Output Frequency		1.0	–	220	MHz	
F _{stab}	Frequency Stability	Inclusive of initial stability, operating temp., rated power supply voltage change, load change	-20 to 70°C	-25	–	+25	ppm
			-40 to 85°C	-50	–	+50	ppm
F _{age}	Aging	First year @ 25°C	–	–	1	PPM	
DC	Duty Cycle		45	–	55	%	
t _R /t _F	Output Rise/Fall Time	20% to 80%	150	230	300	ps	
T _{CCJ}	Cycle-Cycle Jitter	F _{out} = 100 MHz, -0.5% down spread	–	13	22	ps	
		F _{out} = 150 MHz, -0.5% down spread	–	12	19	ps	
		F _{out} = 200 MHz, -0.5% down spread	–	11	20	ps	

CML, 1.8V ± 5%, -40 to 85°C

Symbol	Parameter	Condition	Min.	Typ.	Max.	Unit	
F_{out}	Output Frequency		1.0	-	220	MHz	
F_{stab}	Frequency Stability	Inclusive of initial stability, operating temp., rated power supply voltage change, load change	-20 to 70°C	-25	-	+25	ppm
			-40 to 85°C	-50	-	+50	ppm
F_{age}	Aging	First year @ 25°C	-	-	1	PPM	
DC	Duty Cycle		45	-	55	%	
t_R/t_F	Output Rise/Fall Time	20% to 80%	150	230	300	ps	
T_{CCJ}	Cycle-Cycle Jitter	$F_{out} = 100$ MHz, -0.5% down spread	-	13	23	ps	
		$F_{out} = 150$ MHz, -0.5% down spread	-	12	22	ps	
		$F_{out} = 200$ MHz, -0.5% down spread	-	12	21	ps	

Termination Diagrams

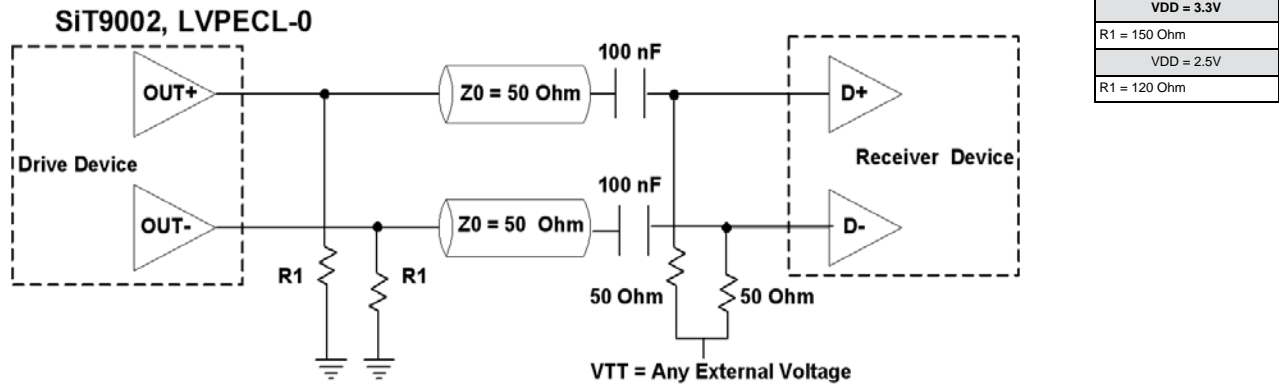

Figure 1. LVPECL AC Coupled Typical Termination

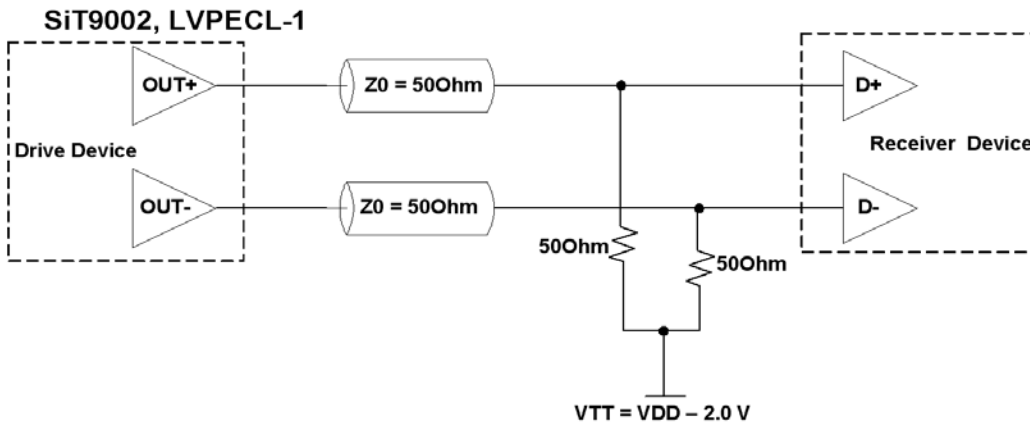

Figure 2. LVPECL DC Coupled Typical Termination with Termination Voltage

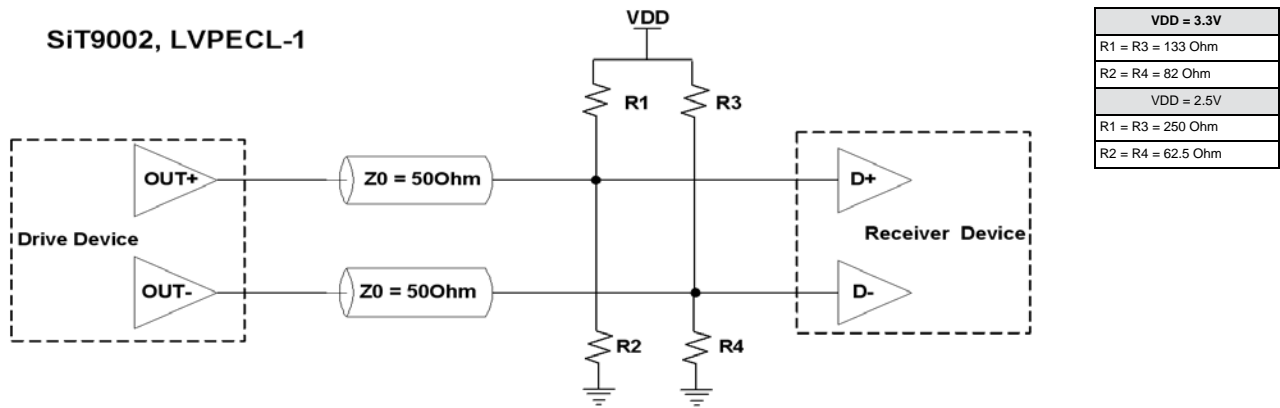

Figure 3. LVPECL DC Coupled Typical Termination without Termination Voltage

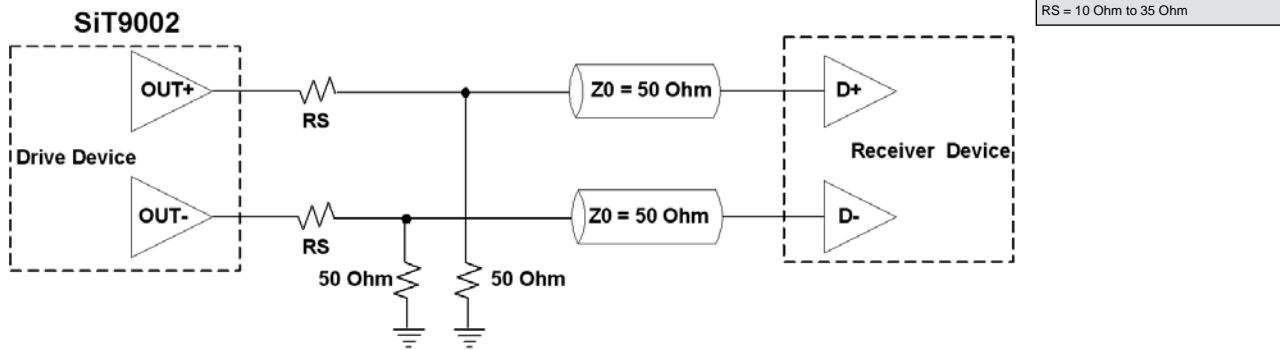

Figure 4. HCSL Typical Termination

Note:

1. All the tests are done with RS = 20 Ohm (recommended).

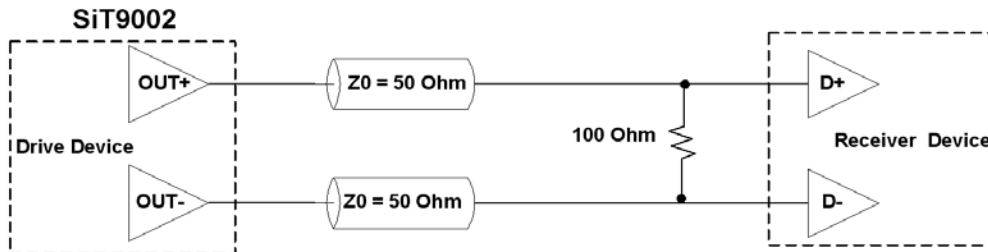
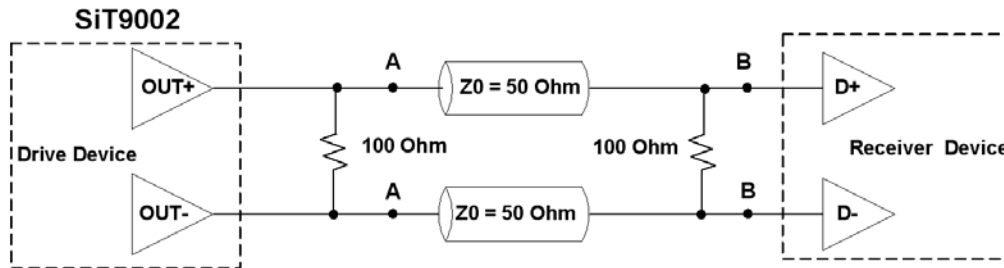

Figure 5. LVDS Single Load Termination (Load Terminated)



Note: For AC coupled operation, include/insert decoupling caps at points A or B

Figure 6. LVDS Double Termination (Source + Load Terminated)

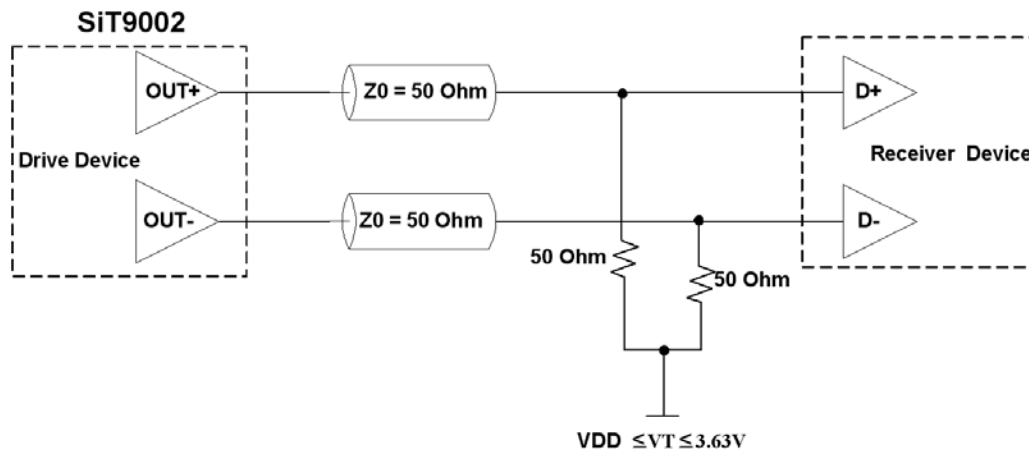
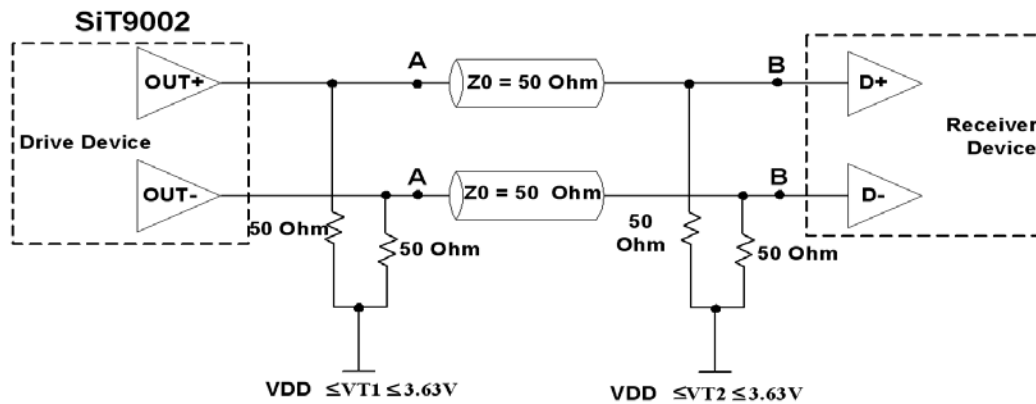

Figure 7. CML Single Load Termination



Notes:

1. For DC-coupled operation, $VT1 = VT2$
2. For AC coupled operation, include/insert decoupling caps at points A or B
3. For AC-coupled operation with capacitors placed at point A, $VT2$ sets the input common mode of Receiver Device and need not to be related to $VT1$

Figure 8. CML Double Load Termination

Ordering Information

The Part No. Guide is for reference only. For real-time customization and exact part number, use the SiTime [Part Number Generator](#).

SiT9002AC -132N33EB123.12345T

Part Family
"SiT9002"

Revision Letter
"A" is the revision of Silicon

Temperature Range
"C" Extended Commercial, -20 to 70°C
"I" Industrial, -40 to 85°C

Signalling Type
"0" = LVPECL-0, (Figure 1)
"1" = LVPECL-1, (Figure 2,3)
"2" = LVDS
"3" = CML
"4" = HCSSL

Package Size
"3" 5.0 x 3.2 mm
"4" 7.0 x 5.0 mm
"8" 7.0 x 5.0 mm^[1]

Frequency Stability
"2" for ±25 PPM
"3" for ±50 PPM

Packaging
"T" for Tape & Reel (3Ku Reel)
"Y" for Tape & Reel (1Ku Reel)
Blank for Bulk

Frequency
1.00000 to 220.00000 MHz

Spread Percentage
Center: "B" = ±0.25, "D" = ±0.50
"G" = ±1.0, "K" = ±2.0
Down: "O" = -0.50, "Q" = -1.0,
"T" = -2.0, "X" = -4.0

Feature Pin
"E" for Output Enable
"S" for Standby
"D" for Spread Disable

Voltage Supply
"18" for 1.8 V ±5% (CML only)
"25" for 2.5 V ±10%
"33" for 3.3 V ±10%

Swing Select
"N" = Normal
"H" = High (LVDS & CML only)

Frequency Stability vs. Temperature Range Options

Frequency Stability (PPM)	Temperature Range	Supply Voltage		
		1.8 V	2.5 V	3.3 V
±25	C (-20 to +70°C)	✓	✓	✓
	I (-40 to +85°C)	✓	✓	✓
±50	C (-20 to +70°C)	✓	✓	✓
	I (-40 to +85°C)	✓	✓	✓

Signalling Type vs. Swing Select Options

Signalling Type	Swing Select	Supply Voltage		
		1.8 V	2.5 V	3.3 V
LVPECL-0	Normal	-	✓	✓
	High	-	-	-
LVPECL-1	Normal	-	✓	✓
	High	-	-	-
LVDS	Normal	-	✓	✓
	High	-	✓	✓
CML	Normal	✓	✓	✓
	High	✓	✓	✓
HCSSL	Normal	-	✓	✓
	High	-	-	-

Note:

1. Without Center Pad.

Package Information [2]

Dimension (mm)

Land Pattern^[3] (recommended) (mm)

5.0 x 3.2 x 0.75mm

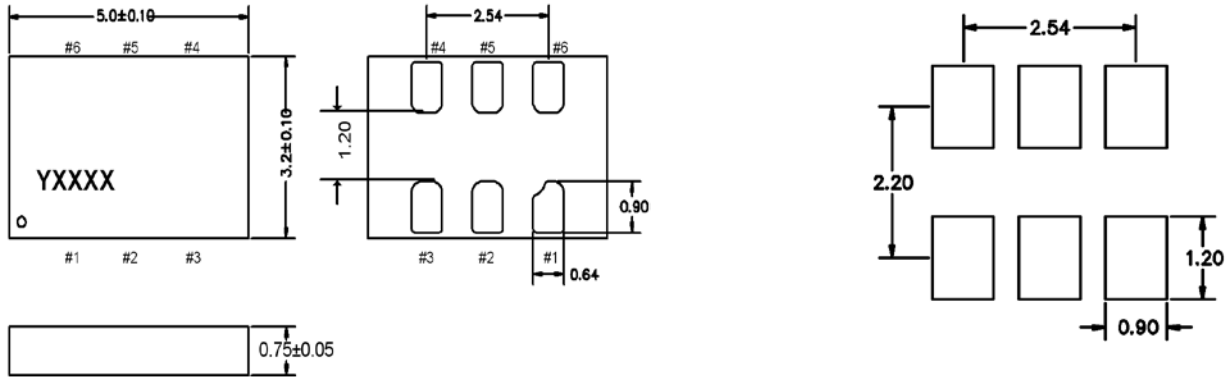

7.0 x 5.0 x 0.90mm

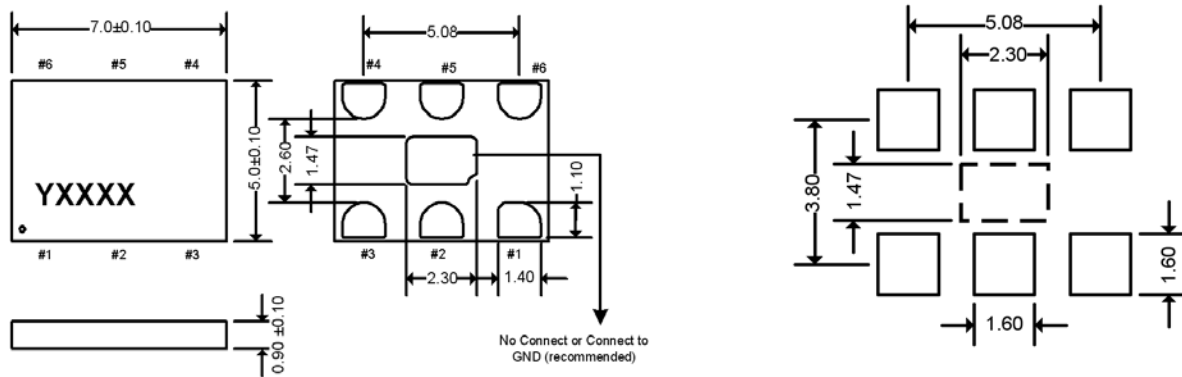

Notes:

2. Y denotes manufacturing origin and XXXX denotes manufacturing lot number. The value of "Y" will depend on the assembly location of the device.
3. A capacitor of value 0.1µF between VDD and GND is recommended.
4. The 7050 package with part number designation "-8" has NO center pad.

© SiTime Corporation 2013. The information contained herein is subject to change at any time without notice. SiTime assumes no responsibility or liability for any loss, damage or defect of a Product which is caused in whole or in part by (i) use of any circuitry other than circuitry embodied in a SiTime product, (ii) misuse or abuse including static discharge, neglect or accident, (iii) unauthorized modification or repairs which have been soldered or altered during assembly and are not capable of being tested by SiTime under its normal test conditions, or (iv) improper installation, storage, handling, warehousing or transportation, or (v) being subjected to unusual physical, thermal, or electrical stress.

Disclaimer: SiTime makes no warranty of any kind, express or implied, with regard to this material, and specifically disclaims any and all express or implied warranties, either in fact or by operation of law, statutory or otherwise, including the implied warranties of merchantability and fitness for use or a particular purpose, and any implied warranty arising from course of dealing or usage of trade, as well as any common-law duties relating to accuracy or lack of negligence, with respect to this material, any SiTime product and any product documentation. Products sold by SiTime are not suitable or intended to be used in a life support application or component, to operate nuclear facilities, or in other mission critical applications where human life may be involved or at stake. All sales are made conditioned upon compliance with the critical uses policy set forth below.

CRITICAL USE EXCLUSION POLICY

BUYER AGREES NOT TO USE SITIME'S PRODUCTS FOR ANY APPLICATION OR IN ANY COMPONENTS USED IN LIFE SUPPORT DEVICES OR TO OPERATE NUCLEAR FACILITIES OR FOR USE IN OTHER MISSION-CRITICAL APPLICATIONS OR COMPONENTS WHERE HUMAN LIFE OR PROPERTY MAY BE AT STAKE.

SiTime owns all rights, title and interest to the intellectual property related to SiTime's products, including any software, firmware, copyright, patent, or trademark. The sale of SiTime products does not convey or imply any license under patent or other rights. SiTime retains the copyright and trademark rights in all documents, catalogs and plans supplied pursuant to or ancillary to the sale of products or services by SiTime. Unless otherwise agreed to in writing by SiTime, any reproduction, modification, translation, compilation, or representation of this material shall be strictly prohibited.

Looking for pricing, stock, or lifecycle information?

Click below to explore more details on WIN SOURCE:

 [View SIT9002AC-232N33DO50.00000 on WIN SOURCE](#)

 [SiTIME Information](#)

Optimize Your Supply Chain with WIN SOURCE Solutions

-  Global Sourcing Solution
-  Obsolete Management
-  Cost Control Management
-  Shortage Management
-  Alternative Solution
-  Excess Inventory Management