

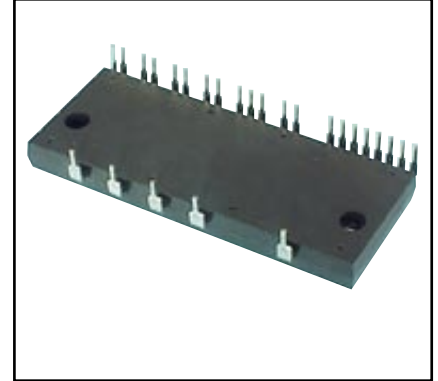

**THE DATASHEET OF
PS21244-EP**

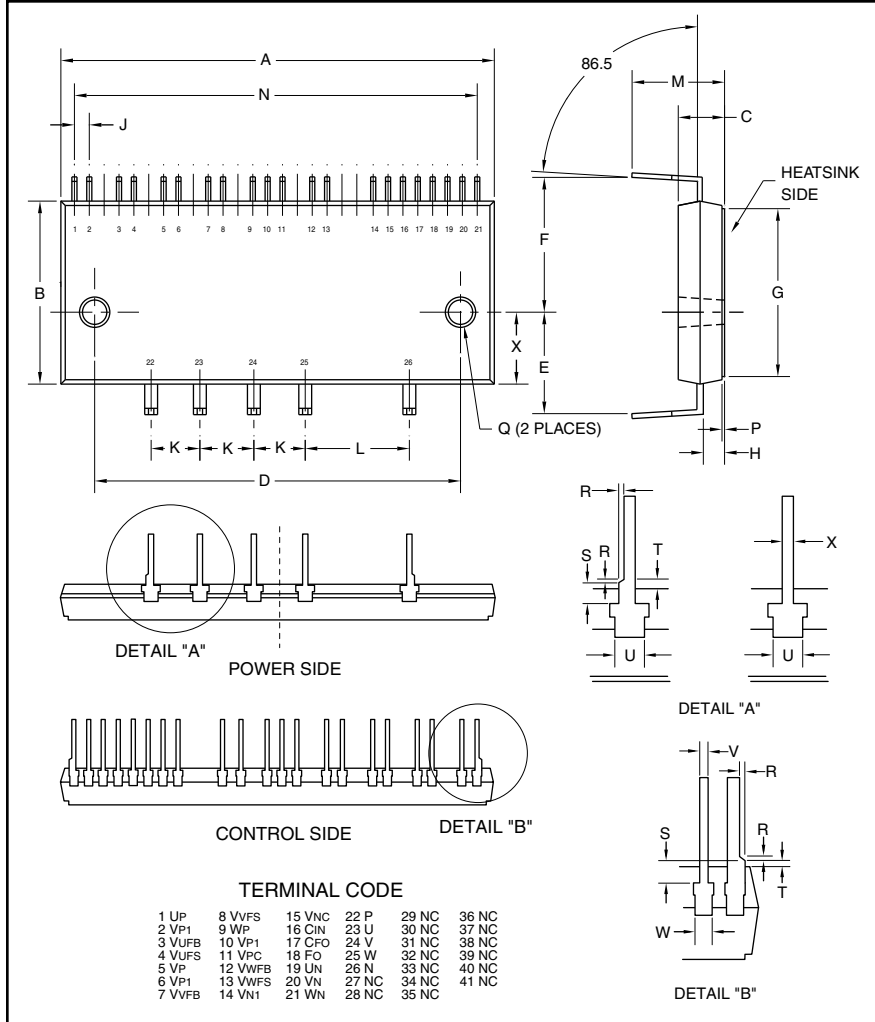

Intellimod™ Module Dual-In-Line Intelligent Power Module 15 Amperes/600 Volts



Description:

DIP and mini-DIP IPMs are intelligent power modules that integrate power devices, drivers, and protection circuitry in an ultra compact dual-in-line transfer-mold package for use in driving small three phase motors. Use of 4th generation IGBTs, DIP packaging, and application specific HVICs allow the designer to reduce inverter size and overall design time.

Features:

- Compact Packages
- Single Power Supply
- Integrated HVICs
- Direct Connection to CPU

Applications:

- Washing Machines
- Refrigerators
- Air Conditioners
- Small Servo Motors
- Small Motor Control

Ordering Information:

PS21244-EP is a 600V, 15 Ampere DIP Intelligent Power Module. Note: P suffix designates lead-free leadframe.

Outline Drawing and Circuit Diagram

| Dimensions | Inches | Millimeters |
|------------|----------------|---------------|
| A | 3.07±0.02 | 79.0±0.5 |
| B | 1.22±0.02 | 31.0±0.5 |
| C | 0.32±0.02 | 8.0±0.5 |
| D | 2.64±0.01 | 67.0±0.3 |
| E | 0.53±0.01 Dia. | 13.4±0.2 Dia. |
| F | 0.84±0.02 | 21.4±0.5 |
| G | 1.10±0.02 | 28.0±0.5 |
| H | 0.15±0.01 | 3.8±0.2 |
| J | 0.11±0.01 | 2.8±0.3 |
| K | 0.39±0.01 | 10.0±0.3 |
| L | 0.79±0.01 | 20.0±0.3 |

| Dimensions | Inches | Millimeters |
|------------|----------------|--------------|
| M | 0.50±0.04 | 12.8±1.0 |
| N | 2.98 | 75.6 |
| P | 0.02±0.01 | 0.5±0.2 |
| Q | 0.18±0.01 Dia. | 4.5±0.2 Dia. |
| R | 0.02 Max. | 0.5 Max. |
| S | 0.08 | 2.0 |
| T | 0.03±0.002 | 0.6±0.05 |
| U | 0.1 | 2.5 |
| V | 0.03±0.01 | 0.8±0.2 |
| W | 0.07 | 1.75 Max. |
| X | 0.4±0.01 | 1.0±0.2 |



Powerex, Inc., 200 Hillis Street, Youngwood, Pennsylvania 15697-1800 (724) 925-7272

PS21244-EP
Intellimod™ Module
Dual-In-Line Intelligent Power Module
 15 Amperes/600 Volts

Absolute Maximum Ratings, $T_j = 25^\circ\text{C}$ unless otherwise specified

| Characteristics | Symbol | PS21244-EP | Units |
|--|-----------------|------------|------------------|
| Power Device Junction Temperature* | T_j | -20 to 150 | $^\circ\text{C}$ |
| Storage Temperature | T_{stg} | -40 to 125 | $^\circ\text{C}$ |
| Case Operating Temperature (See T_C Measure Point Illustration) | T_C | -20 to 100 | $^\circ\text{C}$ |
| Mounting Torque, M4 Mounting Screws | — | 13 | in-lb |
| Module Weight (Typical) | — | 54 | Grams |
| Heatsink Flatness | — | -50 to 100 | μm |
| Self-protection Supply Voltage Limit (Short Circuit Protection Capability)** | $V_{CC(prot.)}$ | 400 | Volts |
| Isolation Voltage, AC 1 minute, 60Hz Sinusoidal, Connection Pins to Heatsink Plate | V_{ISO} | 2500 | Volts |

*The maximum junction temperature rating of the power chips integrated within the DIP-IPM is 150°C ($@T_C \leq 100^\circ\text{C}$). However, to ensure safe operation of the DIP-IPM, the average junction temperature should be limited to $T_{j(avg)} \leq 125^\circ\text{C}$ ($@T_C \leq 100^\circ\text{C}$).

** $V_D = V_{DB} = 13.5 \sim 16.5\text{V}$, Inverter Part, $T_j = 125^\circ\text{C}$, Non-repetitive, Less than $2\mu\text{s}$

IGBT Inverter Sector

| | | | |
|---|-----------------|-----|---------|
| Collector-Emitter Voltage | V_{CES} | 600 | Volts |
| Collector Current, \pm ($T_C = 25^\circ\text{C}$) | I_C | 15 | Amperes |
| Peak Collector Current, \pm ($T_C = 25^\circ\text{C}$, Instantaneous Value (Pulse)) | I_{CP} | 30 | Amperes |
| Supply Voltage (Applied between P - N) | V_{CC} | 450 | Volts |
| Supply Voltage, Surge (Applied between P - N) | $V_{CC(surge)}$ | 500 | Volts |
| Collector Dissipation ($T_C = 25^\circ\text{C}$, per 1 Chip) | P_C | 43 | Watts |

Control Sector

| | | | |
|---|-----------|------------------|-------|
| Supply Voltage (Applied between $V_{P1}-V_{PC}$, $V_{N1}-V_{NC}$) | V_D | 20 | Volts |
| Supply Voltage (Applied between $V_{UFB}-V_{UFS}$, $V_{VFB}-V_{VFS}$, $V_{WFB}-V_{WFS}$) | V_{DB} | 20 | Volts |
| Input Voltage (Applied between U_P, V_P, W_P-V_{PC} , U_N, V_N, W_N-V_{NC}) | V_{CIN} | -0.5 ~ 5.5 | Volts |
| Fault Output Supply Voltage (Applied between F_O-V_{NC}) | V_{FO} | -0.5 ~ $V_D+0.5$ | Volts |
| Fault Output Current (Sink Current at F_O Terminal) | I_{FO} | 15 | mA |
| Current Sensing Input Voltage (Applied between $C_{IN}-V_{NC}$) | V_{SC} | -0.5 ~ $V_D+0.5$ | Volts |

PS21244-EP
Intellimod™ Module
Dual-In-Line Intelligent Power Module
 15 Amperes/600 Volts

Electrical and Mechanical Characteristics, $T_j = 25^\circ\text{C}$ unless otherwise specified

| Characteristics | Symbol | Test Conditions | Min. | Typ. | Max. | Units |
|--------------------------------------|---------------|---|------|------|------|---------------|
| IGBT Inverter Sector | | | | | | |
| Collector Cutoff Current | I_{CES} | $V_{CE} = V_{CES}, T_j = 25^\circ\text{C}$ | — | — | 1.0 | mA |
| | | $V_{CE} = V_{CES}, T_j = 125^\circ\text{C}$ | — | — | 10 | mA |
| Diode Forward Voltage | V_{EC} | $T_j = 25^\circ\text{C}, -I_C = 15\text{A}, V_{CIN} = 5\text{V}$ | — | 2.5 | 3.4 | Volts |
| Collector-Emitter Saturation Voltage | $V_{CE(sat)}$ | $I_C = 15\text{A}, T_j = 25^\circ\text{C}, V_D = V_{DB} = 15\text{V}, V_{CIN} = 0\text{V}$ | — | 1.55 | 2.15 | Volts |
| | | $I_C = 15\text{A}, T_j = 125^\circ\text{C}, V_D = V_{DB} = 15\text{V}, V_{CIN} = 0\text{V}$ | — | 1.65 | 2.25 | Volts |
| Inductive Load Switching Times | t_{on} | $V_{CC} = 300\text{V}, V_D = 15\text{V},$ | 0.1 | 0.7 | 1.2 | μS |
| | t_{rr} | $I_C = 15\text{A},$ | — | 0.1 | — | μS |
| | $t_{C(on)}$ | $T_j = 125^\circ\text{C},$ | — | 0.4 | 0.8 | μS |
| | t_{off} | Inductive Load (Upper-Lower Arm), | — | 1.5 | 2.6 | μS |
| | $t_{C(off)}$ | $V_{CIN} = 5\text{V(off)}, 0\text{V(on)}$ | — | 0.9 | 1.8 | μS |

T_C Measure Point

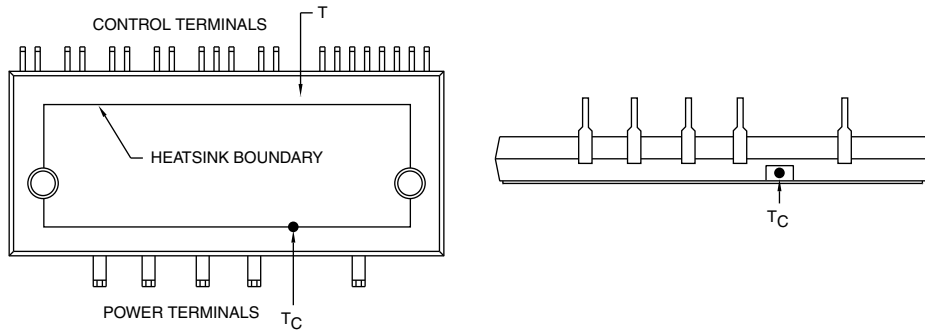



Powerex, Inc., 200 Hillis Street, Youngwood, Pennsylvania 15697-1800 (724) 925-7272

PS21244-EP
Intellimod™ Module
Dual-In-Line Intelligent Power Module
 15 Amperes/600 Volts

Electrical and Mechanical Characteristics, $T_j = 25^\circ\text{C}$ unless otherwise specified

| Characteristics | Symbol | Test Conditions | Min. | Typ. | Max. | Units |
|--------------------------------|---------------|---|------|------|------|---------------|
| Control Sector | | | | | | |
| Supply Voltage | V_D | Applied between V_{P1} - V_{PC} , V_{N1} - V_{NC} | 13.5 | 15.0 | 16.5 | Volts |
| | V_{DB} | Applied between V_{UFB} - V_{UFS} , V_{VFB} - V_{VFS} , V_{WFB} - V_{WFS} | 13.5 | 15.0 | 16.5 | Volts |
| Circuit Current | I_D | $V_D = 15\text{V}$, $V_{CIN} = 5\text{V}$, $V_{DB} = 15\text{V}$, Total of V_{P1} - V_{PC} , V_{N1} - V_{NC} | — | 4.25 | 8.50 | mA |
| | | $V_D = 15\text{V}$, $V_{CIN} = 5\text{V}$, $V_{DB} = 15\text{V}$, V_{UFB} - V_{UFS} , V_{VFB} - V_{VFS} , V_{WFB} - V_{WFS} | — | 0.50 | 1.00 | mA |
| Fault Output Voltage | V_{FOH} | $V_{SC} = 0\text{V}$, F_O Circuit: 10k Ω to 5V Pull-up | 4.9 | — | — | Volts |
| | V_{FOL} | $V_{SC} = 1\text{V}$, F_O Circuit: 10k Ω to 5V Pull-up | — | 0.8 | 1.2 | Volts |
| | $V_{FO(sat)}$ | $V_{SC} = 1\text{V}$, $I_{FO} = 15\text{mA}$ | 0.8 | 1.2 | 1.8 | Volts |
| PWM Input Frequency | f_{PWM} | $T_C \leq 100^\circ\text{C}$, $T_j \leq 125^\circ\text{C}$ | — | 15 | — | kHz |
| Allowable Dead Time | t_{DEAD} | Relates to Corresponding Input Signal for Blocking Arm Shoot-through ($-20^\circ\text{C} \leq T_C \leq 100^\circ\text{C}$) | 2.5 | — | — | μs |
| Short Circuit Trip Level* | $V_{SC(ref)}$ | $T_j = 25^\circ\text{C}$, $V_D = 15\text{V}^*$ | 0.45 | 0.5 | 0.55 | Volts |
| Supply Circuit Under-voltage | UV_{DBt} | Trip Level, $T_j \leq 125^\circ\text{C}$ | 10.0 | — | 12.0 | Volts |
| | UV_{DBr} | Reset Level, $T_j \leq 125^\circ\text{C}$ | 10.5 | — | 12.5 | Volts |
| | UV_{Dt} | Trip Level, $T_j \leq 125^\circ\text{C}$ | 10.3 | — | 12.5 | Volts |
| | UV_{Dr} | Reset Level, $T_j \leq 125^\circ\text{C}$ | 10.8 | — | 13.0 | Volts |
| Fault Output Pulse Width** | t_{FO} | $C_{FO} = 22\text{nF}$ | 1.0 | 1.8 | — | mS |
| ON Threshold Voltage (H-side) | $V_{th(on)}$ | Applied between | 0.8 | 1.4 | 2.0 | Volts |
| OFF Threshold Voltage (H-side) | $V_{th(off)}$ | U_P , V_P , W_P - V_{PC} | 2.5 | 3.0 | 4.0 | Volts |
| ON Threshold Voltage (L-side) | $V_{th(on)}$ | Applied between | 0.8 | 1.4 | 2.0 | Volts |
| OFF Threshold Voltage (L-side) | $V_{th(off)}$ | U_N , V_N , W_N - V_{NC} | 2.5 | 3.0 | 4.0 | Volts |

* Short Circuit protection is functioning only at the low-arms. Please select the value of the external shunt resistor such that the SC trip level is less than 25.5A.

**Fault signal is asserted when the low-arm short circuit or control supply under-voltage protective functions operate. The fault output pulse-width t_{FO} depends on the capacitance value of C_{FO} according to the following approximate equation: $C_{FO} = (12.2 \times 10^{-6}) \times t_{FO} \{F\}$.



Powerex, Inc., 200 Hillis Street, Youngwood, Pennsylvania 15697-1800 (724) 925-7272

PS21244-EP
Intellimod™ Module
Dual-In-Line Intelligent Power Module
 15 Amperes/600 Volts

Thermal Characteristics

| Characteristic | Symbol | Condition | Min. | Typ. | Max. | Units |
|----------------------------|----------------|---|------|------|-------|---------|
| Junction to Case | $R_{th(j-c)Q}$ | Each IGBT | — | — | 2.85 | °C/Watt |
| | $R_{th(j-c)D}$ | Each FWDi | — | — | 4.5 | °C/Watt |
| Contact Thermal Resistance | $R_{th(c-f)}$ | Case to Fin Per Module. Thermal Grease Applied | — | — | 0.067 | °C/Watt |

Recommended Conditions for Use

| Characteristic | Symbol | Condition | Min. | Typ. | Value | Units |
|---------------------------------|--------------------------|--|------|------|-----------|-------|
| Supply Voltage | V_{CC} | Applied between P-N Terminals | 0 | 300 | 400 | Volts |
| Control Supply Voltage | V_D | Applied between $V_{P1}-V_{PC}$, $V_{N1}-V_{NC}$ | 13.5 | 15.0 | 16.5 | Volts |
| | V_{DB} | Applied between $V_{UFB}-V_{UFS}$, $V_{VFB}-V_{VFS}$, $V_{WFB}-V_{WFS}$ | 13.5 | 15.0 | 16.5 | Volts |
| Control Supply dv/dt | dV_D/dt , dV_{DB}/dt | | -1 | — | 1 | V/μs |
| Input ON Voltage | $V_{CIN(on)}$ | Applied between U_P , V_P , W_P-V_{PC} | | | 0 ~ 0.65 | Volts |
| Input OFF Voltage | $V_{CIN(off)}$ | Applied between U_N , V_N , W_N-V_{NC} | | | 4.0 ~ 5.5 | Volts |
| PWM Input Frequency | f_{PWM} | $T_C \leq 100^\circ\text{C}$, $T_J \leq 125^\circ\text{C}$ | — | 5 | — | kHz |
| Arm Shoot-through Blocking Time | t_{DEAD} | For Each Input Signal | 2.5 | — | — | μs |

PS21244-EP
Intellimod™ Module
Dual-In-Line Intelligent Power Module
 15 Amperes/600 Volts

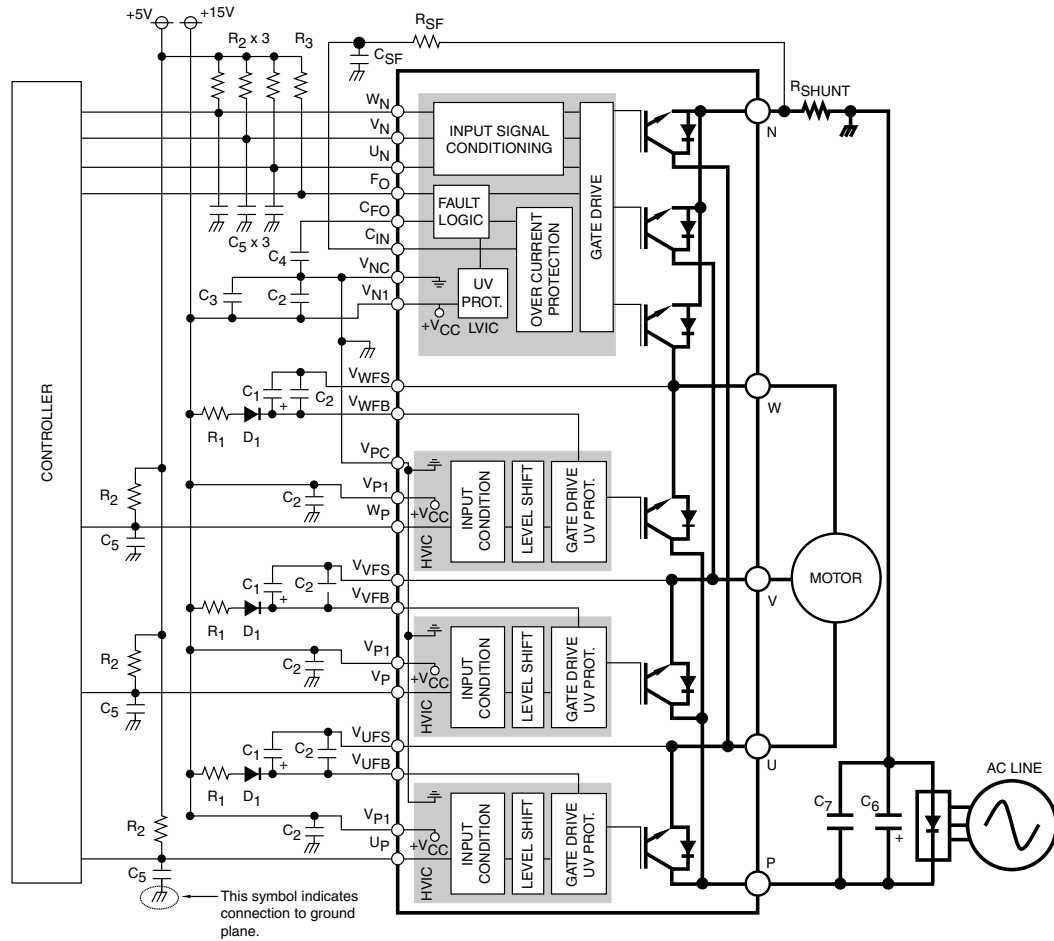

Component Selection:

| Dsgn. | Typ. Value | Description |
|----------------|------------------|---|
| D ₁ | 1A, 600V | Boot strap supply diode – Ultra fast recovery |
| C ₁ | 10-100uF, 50V | Boot strap supply reservoir – Electrolytic, long life, low Impedance, 105°C (Note 5) |
| C ₂ | 0.22-2.0uF, 50V | Local decoupling/High frequency noise filters – Multilayer ceramic (Note 8) |
| C ₃ | 1-100uF, 50V | Control power supply filter – Electrolytic, long life, low Impedance, 105°C |
| C ₄ | 22nF, 50V | Fault lock-out timing capacitor – Multilayer ceramic (Note 4) |
| C ₅ | 100-1000pF, 50V | Input signal noise filter – Multilayer ceramic (Note 1) |
| C ₆ | 200-2000uF, 450V | Main DC bus filter capacitor – Electrolytic, long life, high ripple current, 105°C |
| C ₇ | 0.1-0.22uF, 450V | Surge voltage suppression capacitor – Polyester/Polypropylene film (Note 9) |
| CSF | 1000pF, 50V | Short circuit detection filter capacitor – Multilayer Ceramic (Note 6, Note 7) |
| RSF | 1.8k ohm | Short circuit detection filter resistor (Note 6, Note 7) |
| RSHUNT | 5-100 mohm | Current sensing resistor - Non-inductive, temperature stable, tight tolerance (Note 10) |
| R ₁ | 1-100 ohm | Boot strap supply inrush limiting resistor (Note 5) |
| R ₂ | 4.7k ohm | Control input pull-up resistor (Note 1, Note 2) |
| R ₃ | 5.1k ohm | Fault output signal pull-up resistor (Note 3) |

Notes:

- 1) To prevent input signal oscillations minimize wiring length to controller (~2cm). Additional RC filtering (C5 etc.) may be required. If filtering is added be careful to maintain proper dead time. See application notes for details.
- 2) Internal HVIC provides high voltage level shifting allowing direct connection of all six driving signals to the controller.
- 3) F_O output is an open collector type. This signal should be pulled high with 5.1k ohm resistor (R₃).
- 4) C₄ sets the fault output duration and lock-out time. $C_4 = 12.2E^{-6} \times t_{FO} \times t_{FO}$, 22nF gives ~1.8ms
- 5) Boot strap supply component values must be adjusted depending on the PWM frequency and technique.
- 6) Wiring length associated with R_{SHUNT}, R_{SF}, C_{SF} must be minimized to avoid improper operation of the OC function.
- 7) R_{SF}, C_{SF} set over current protection trip time. Recommend time constant is 1.5us-2.0us. See application notes.
- 8) Local decoupling/high frequency filter capacitors must be connected as close as possible to the modules pins.
- 9) The length of the DC link wiring between C₆, C₇, the DIP's P terminal and the shunt must be minimized to prevent excessive transient voltages. In particular C₇ should be mounted as close to the DIP as possible.
- 10) Use high quality, tight tolerance current sensing resistor. Connect resistor as close as possible to the DIP's N terminal. Be careful to check for proper power rating. See application notes for calculation of resistance value.

Looking for pricing, stock, or lifecycle information?

Click below to explore more details on WIN SOURCE:

 [View PS21244-EP on WIN SOURCE](#)

 [Powerex Inc. Information](#)

Optimize Your Supply Chain with WIN SOURCE Solutions

-  Global Sourcing Solution
-  Obsolete Management
-  Cost Control Management
-  Shortage Management
-  Alternative Solution
-  Excess Inventory Management