



**THE DATASHEET OF
5T9070PAGI8**



FEATURES:

- Optimized for 2.5V LVTTTL
- Guaranteed Low Skew < 125ps (max)
- Very low duty cycle distortion < 300ps (max)
- High speed propagation delay < 2ns. (max)
- Up to 200MHz operation
- Very low CMOS power levels
- Hot insertable and over-voltage tolerant inputs
- 1:10 fanout buffer
- 2.5V V_{DD}
- Available in TSSOP package
- **NOT RECOMMENDED FOR NEW DESIGNS**
- *For replacement part use 8T39S11*

APPLICATIONS:

- Clock and signal distribution

DESCRIPTION:

The 5t9070 2.5V single data rate (SDR) clock buffer is a single-ended input to ten single-ended outputs buffer built on advanced metal CMOS technology. The SDR clock buffer fanout from a single input to ten single-ended outputs reduces the loading on the preceding driver and provides an efficient clock distribution network.

The 5t9070 has two output banks that can be asynchronously enabled/disabled. Multiple power and grounds reduce noise.

FUNCTIONAL BLOCK DIAGRAM

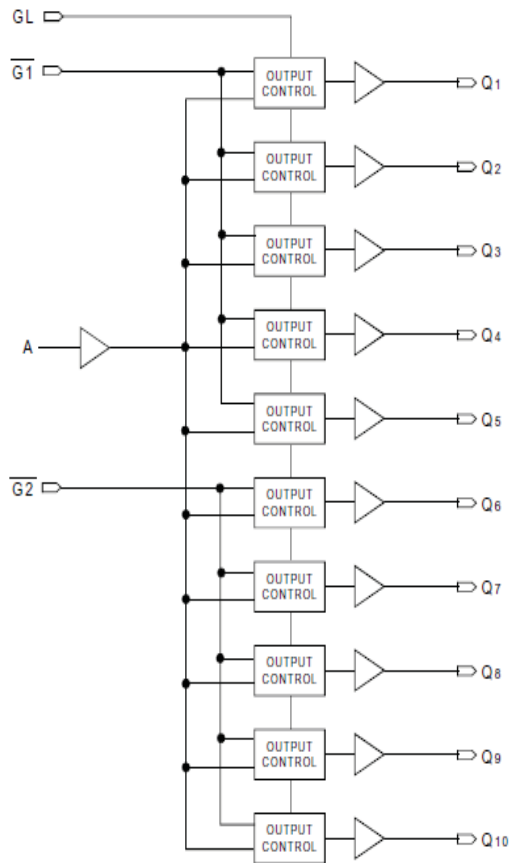

PIN CONFIGURATION

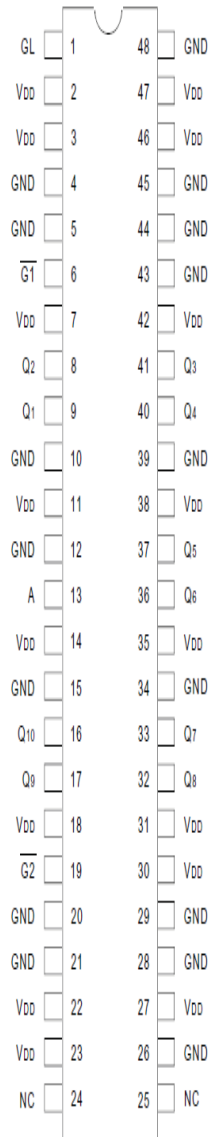

TSSOP
TOP VIEW

ABSOLUTE MAXIMUM RATINGS⁽¹⁾

Symbol	Description	Max	Unit
V _{DD}	Power Supply Voltage	-0.5 to +3.6	V
V _I	Input Voltage	-0.5 to +3.6	V
V _O	Output Voltage	-0.5 to V _{DD} + 0.5	V
T _{STG}	Storage Temperature	-65 to +165	°C
T _J	Junction Temperature	150	°C

NOTE:

- Stresses greater than those listed under ABSOLUTE MAXIMUM RATINGS may cause permanent damage to the device. This is a stress rating only and functional operation of the device at these or any other conditions above those indicated in the operational sections of this specification is not implied. Exposure to absolute maximum rating conditions for extended periods may affect reliability.

CAPACITANCE⁽¹⁾ (T_A = +25°C, F = 1.0MHz)

Symbol	Parameter	Min	Typ.	Max.	Unit
C _{IN}	Input Capacitance	—	6	—	pF

NOTE:

- This parameter is measured at characterization but not tested.

RECOMMENDED OPERATING RANGE

Symbol	Description	Min.	Typ.	Max.	Unit
T _A	Ambient Operating Temperature	-40	+25	+85	°C
V _{DD}	Internal Power Supply Voltage	2.3	2.5	2.7	V

PIN DESCRIPTION

Symbol	I/O	Type	Description
A	I	LVTTTL	Clock input
$\overline{G1}$	I	LVTTTL	Gate for outputs Q1 through Q5. When $\overline{G1}$ is LOW, these outputs are enabled. When $\overline{G1}$ is HIGH, these outputs are asynchronously disabled to the level designated by $G1^{(1)}$.
$\overline{G2}$	I	LVTTTL	Gate for outputs Q6 through Q10. When $\overline{G2}$ is LOW, these outputs are enabled. When $\overline{G2}$ is HIGH, these outputs are asynchronously disabled to the level designated by $G1^{(1)}$.
$G1$	I	LVTTTL	Specifies output disable level. If HIGH, the outputs disable HIGH. If LOW, the outputs disable LOW.
Qn	O	LVTTTL	Clock outputs
V_{DD}		PWR	Power supply for the device core, inputs, and outputs
GND		PWR	Power supply return for power

NOTE:

1. Because the gate controls are asynchronous, runt pulses are possible. It is the user's responsibility to either time the gate control signals to minimize the possibility of runt pulses or be able to tolerate them in down stream circuitry.

DC ELECTRICAL CHARACTERISTICS OVER OPERATING RANGE ⁽¹⁾

Symbol	Parameter	Test Conditions	Min.	Typ. ⁽⁴⁾	Max	Unit
I_{IH}	Input HIGH Current	$V_{DD} = 2.7V$ $V_I = V_{DD}/GND$	—	—	+5	μA
I_{IL}	Input LOW Current	$V_{DD} = 2.7V$ $V_I = GND/V_{DD}$	—	—	+5	
V_{IK}	Clamp Diode Voltage	$V_{DD} = 2.3V$, $I_{IN} = -18mA$	—	-0.7	-1.2	V
V_{IN}	DC Input Voltage		-0.3		+3.6	V
V_{IH}	DC Input HIGH ⁽²⁾		1.7		—	V
V_{IL}	DC Input LOW ⁽³⁾		—		0.7	V
V_{OH}	Output HIGH Voltage	$I_{OH} = -12mA$	$V_{DD} - 0.4$		—	V
V_{OL}	Output LOW Voltage	$I_{OH} = -100\mu A$	$V_{DD} - 0.1$		—	V
		$I_{OL} = 12mA$	—		0.4	V
		$I_{OL} = 100\mu A$	—		0.1	V

NOTES:

1. See RECOMMENDED OPERATING RANGE table.
2. Voltage required to maintain a logic HIGH.
3. Voltage required to maintain a logic LOW.
4. Typical values are at $V_{DD} = 2.5V$, +25°C ambient.

POWER SUPPLY CHARACTERISTICS

Symbol	Parameter	Test Conditions ⁽¹⁾	Typ.	Max	Unit
I _{DD0}	Quiescent V _{DD} Power Supply Current	V _{DD} = Max., Reference Clock = LOW Outputs enabled. All outputs unloaded	1.5	2	mA
I _{DD}	Dynamic V _{DD} Power Supply Current per Output	V _{DD} = Max., V _{DD} = Max., C _L = 0pF	150	200	μA/MHz
I _{TOT}	Total Power V _{DD} Supply Current	V _{DD} = 2.5V., F _{REFERENCE CLOCK} = 100MHz, C _L = 15pF	70	90	mA
		V _{DD} = 2.5V., F _{REFERENCE CLOCK} = 200MHz, C _L = 15pF	100	150	

NOTE:

1. The termination resistors are excluded from these measurements.

INPUT AC TEST CONDITIONS

Symbol	Parameter	Value	Units
V _{IH}	Input HIGH Voltage	V _{DD}	V
V _{IL}	Input LOW Voltage	0	V
V _{TH}	Input Timing Measurement Reference Level ⁽¹⁾	V _{DD} /2	V
t _R , t _F	Input Signal Edge Rate ⁽²⁾	2	V/ns

NOTES:

1. A nominal 1.25V timing measurement reference level is specified to allow constant, repeatable results in an automatic test equipment (ATE) environment.
2. The input signal edge rate of 2V/ns or greater is to be maintained in the 10% to 90% range of the input waveform.

AC ELECTRICAL CHARACTERISTICS OVER OPERATING RANGE⁽⁴⁾

Symbol	Parameter	Min.	Typ.	Max	Unit
Skew Parameters					
t _{SK(O)}	Same Device Output Pin-to-Pin Skew ⁽¹⁾	—	—	125	ps
t _{SK(P)}	Pulse Skew ⁽²⁾	—	—	300	ps
t _{SK(PP)}	Part-to-Part Skew ⁽³⁾	—	—	300	ps
Propagation Delay					
t _{PLH}	Propagation Delay A to Qn	—	—	2	ns
t _{PHL}					
t _R	Output Rise Time (20% to 80%)	350	—	850	ps
t _F	Output Fall Time (20% to 80%)	350	—	850	ps
f _O	Frequency Range	—	—	200	MHz
Output Gate Enable/Disable Delay					
t _{PE}	Output Gate Enable to Qn	—	—	3.5	ns
t _{PGD}	Output Gate Enable to Qn Driven to GL Designated Level	—	—	3	ns

NOTES:

1. Skew measured between all outputs under identical input and output transitions and load conditions on any one device.
2. Skew measured is the difference between propagation delay times t_{PHL} and t_{PLH} of any output under identical input and output transitions and load conditions on any one device.
3. Skew measured is the magnitude of the difference in propagation times between any outputs of two devices, given identical transitions and load conditions at identical V_{DD} levels and temperature.
4. Guaranteed by design.

AC TIMING WAVEFORMS

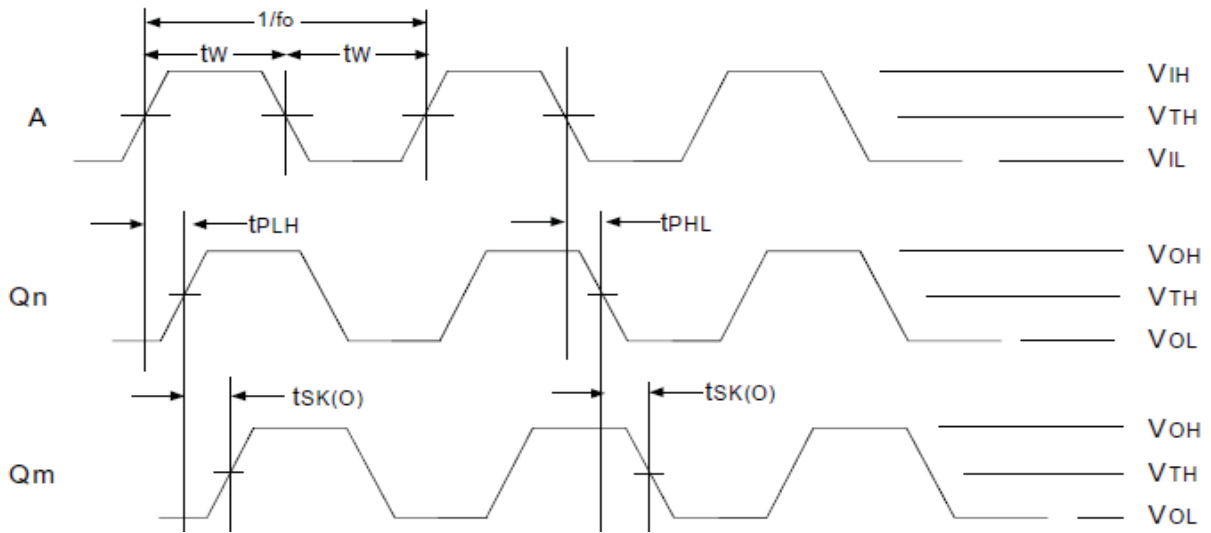

Propagation and Skew Waveforms

NOTE: Pulse Skew is calculated using the following expression:

$$t_{SK(P)} = |t_{PHL} - t_{PLH}|$$

where t_{PHL} and t_{PLH} are measured on the controlled edges of any one output from rising and falling edges of a single pulse. Please note that the t_{PHL} and t_{PLH} shown are not valid measurements for this calculation because they are not taken from the same pulse.

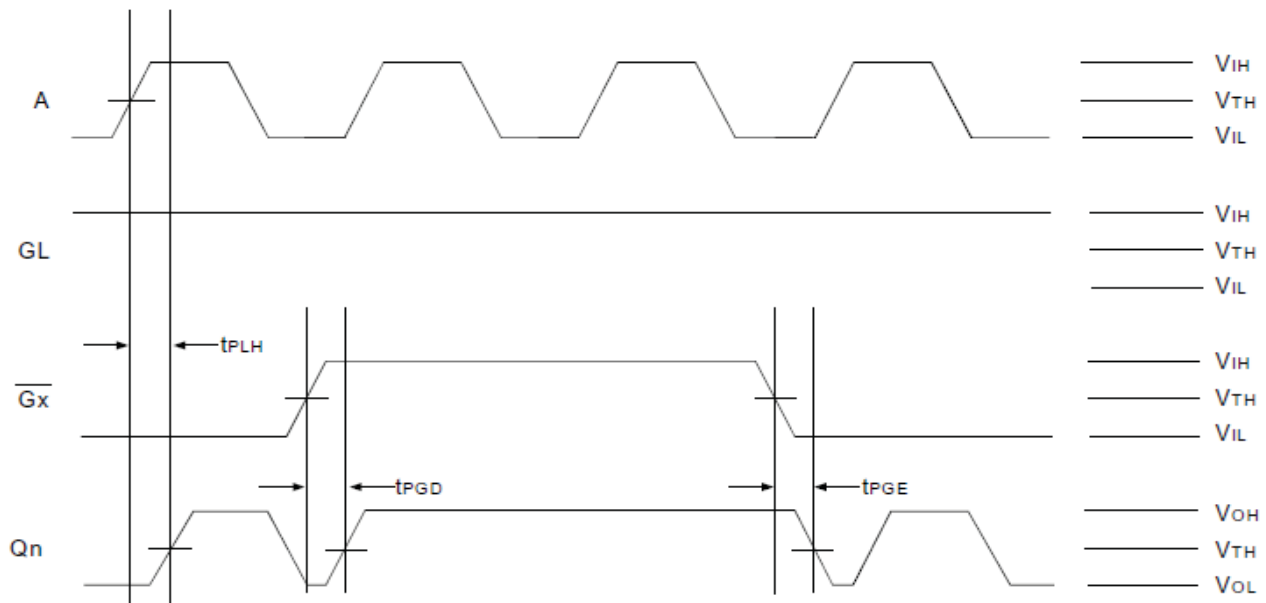

Gate Disable/Enable Runt Pulse Generation

NOTE:

As shown, it is possible to generate runt pulses on gate disable and enable of the outputs. It is the user's responsibility to time their \overline{Gx} signals to avoid this problem.

TEST CIRCUIT AND CONDITIONS

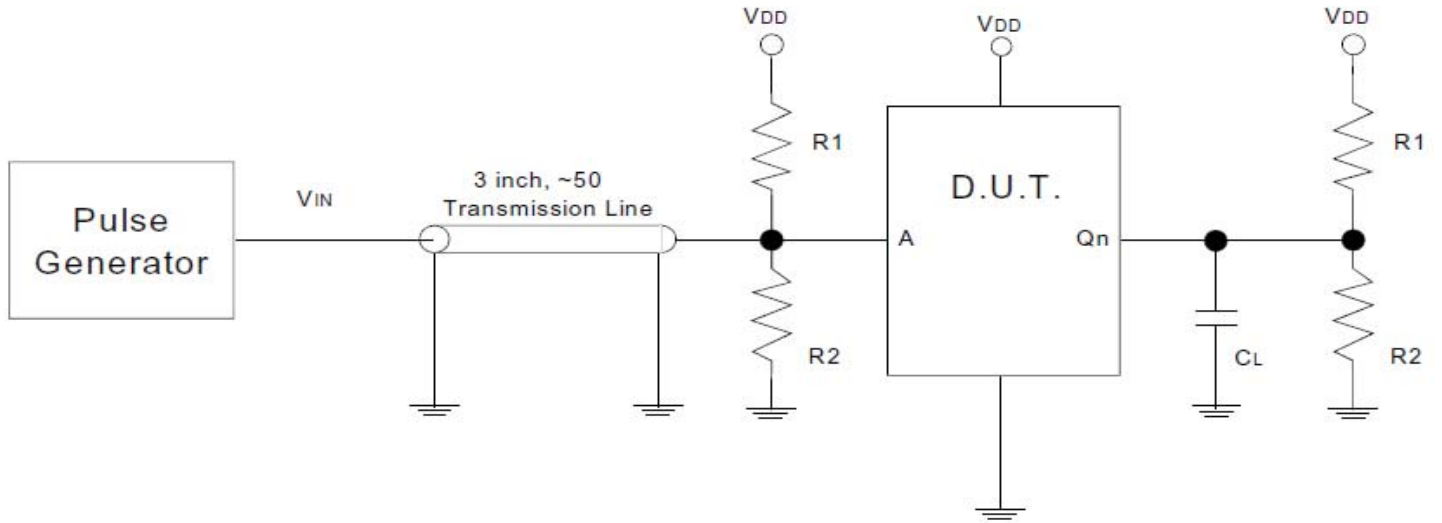

Test Circuit for Input/Output

INPUT/OUTPUT TEST CONDITIONS

Symbol	$V_{DD} = 2.5V \pm 0.2V$	Unit
V_{TH}	$V_{DD} / 2$	V
R1	100	Ω
R2	100	Ω
C_L	15	pF

ORDERING INFORMATION

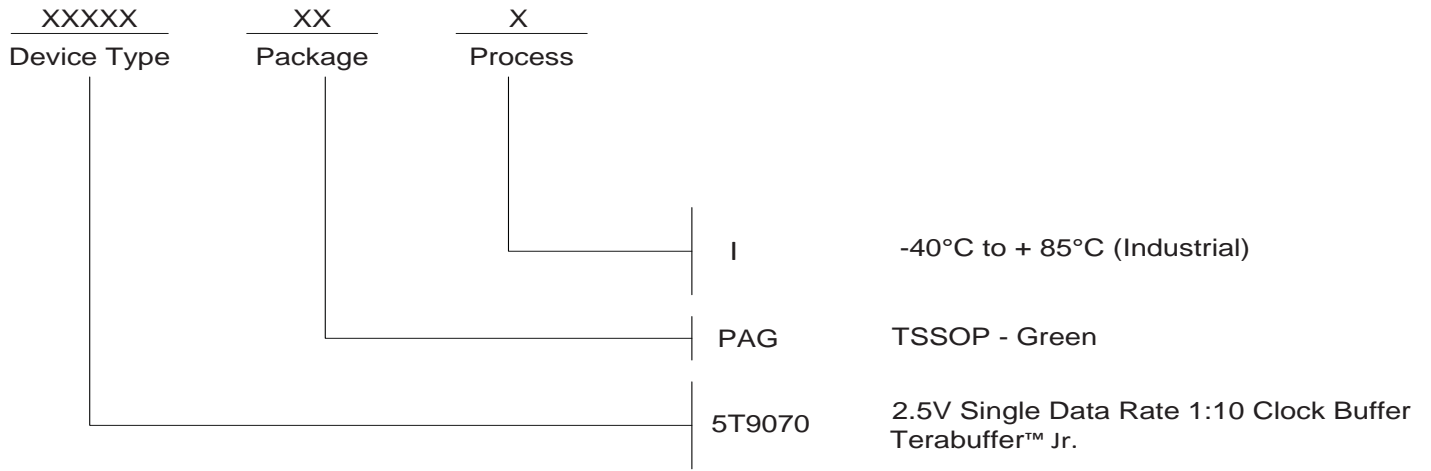

REVISION HISTORY

Rev	Table	Page	Discription of Change	Date
A		1	NRND - Not Recommended for New Designs	5/5/13
A		7	Ordering Information - removed PA leaded device Updated datsheet format	4/14/15
A		1	Product Discontinuation Notice - Last Time Buy Expires September 7, 2016. PDN# N-16-02.	3/10/16

IMPORTANT NOTICE AND DISCLAIMER

RENESAS ELECTRONICS CORPORATION AND ITS SUBSIDIARIES (“RENESAS”) PROVIDES TECHNICAL SPECIFICATIONS AND RELIABILITY DATA (INCLUDING DATASHEETS), DESIGN RESOURCES (INCLUDING REFERENCE DESIGNS), APPLICATION OR OTHER DESIGN ADVICE, WEB TOOLS, SAFETY INFORMATION, AND OTHER RESOURCES “AS IS” AND WITH ALL FAULTS, AND DISCLAIMS ALL WARRANTIES, EXPRESS OR IMPLIED, INCLUDING, WITHOUT LIMITATION, ANY IMPLIED WARRANTIES OF MERCHANTABILITY, FITNESS FOR A PARTICULAR PURPOSE, OR NON-INFRINGEMENT OF THIRD-PARTY INTELLECTUAL PROPERTY RIGHTS.

These resources are intended for developers who are designing with Renesas products. You are solely responsible for (1) selecting the appropriate products for your application, (2) designing, validating, and testing your application, and (3) ensuring your application meets applicable standards, and any other safety, security, or other requirements. These resources are subject to change without notice. Renesas grants you permission to use these resources only to develop an application that uses Renesas products. Other reproduction or use of these resources is strictly prohibited. No license is granted to any other Renesas intellectual property or to any third-party intellectual property. Renesas disclaims responsibility for, and you will fully indemnify Renesas and its representatives against, any claims, damages, costs, losses, or liabilities arising from your use of these resources. Renesas' products are provided only subject to Renesas' Terms and Conditions of Sale or other applicable terms agreed to in writing. No use of any Renesas resources expands or otherwise alters any applicable warranties or warranty disclaimers for these products.

(Disclaimer Rev.1.01 Jan 2024)

Corporate Headquarters

TOYOSU FORESIA, 3-2-24 Toyosu,
Koto-ku, Tokyo 135-0061, Japan
www.renesas.com

Trademarks



Renesas and the Renesas logo are trademarks of Renesas Electronics Corporation. All trademarks and registered trademarks are the property of their respective owners.

Contact Information

For further information on a product, technology, the most up-to-date version of a document, or your nearest sales office, please visit www.renesas.com/contact-us/.

Looking for pricing, stock, or lifecycle information?

Click below to explore more details on WIN SOURCE:

-  [View 5T9070PAGI8 on WIN SOURCE](#)
-  [Renesas Electronics America](#) Information

Optimize Your Supply Chain with WIN SOURCE Solutions

-  Global Sourcing Solution
-  Obsolete Management
-  Cost Control Management
-  Shortage Management
-  Alternative Solution
-  Excess Inventory Management