



**THE DATASHEET OF**  
**1493K-17LFT**



**Description**

The ICS1493-17 is a low-power, low-jitter clock synthesizer designed to replace multiple crystals and oscillators in portable audio/video systems. The device generates a 37 MHz processor clock, a 48 MHz USB clock, a fixed 22.5792 MHz audio clock, a selectable 24.576 MHz or 22.5792 MHz audio clock, and a 27MHz reference clock for video. Using ICS' proprietary mix of analog and digital Phase-Locked Loop (PLL) technology, the device spreads the frequency spectrum of the 37 MHz output, reducing the peak amplitude of by up to 16 dB. An output enable (OE) pin lowers the chip power consumption while tri-stating all outputs.

**Features**

- Extremely low operating current (11 mA)
- Packaged in 20-pin QFN (Pb-free)
- Input crystal or clock frequency of 27 MHz
- Output reference frequency of 27 MHz
- Fixed output frequencies of 37 MHz, 48 MHz and 22.5792 MHz
- Selectable output frequency of either 22.5792 MHz or 24.576 MHz
- Configurable spread spectrum on 37 MHz output
- Operating core voltage of 1.8 V
- Output voltage of 1.8 V or 2.5 V
- Advanced, low-power CMOS process

**Block Diagram**

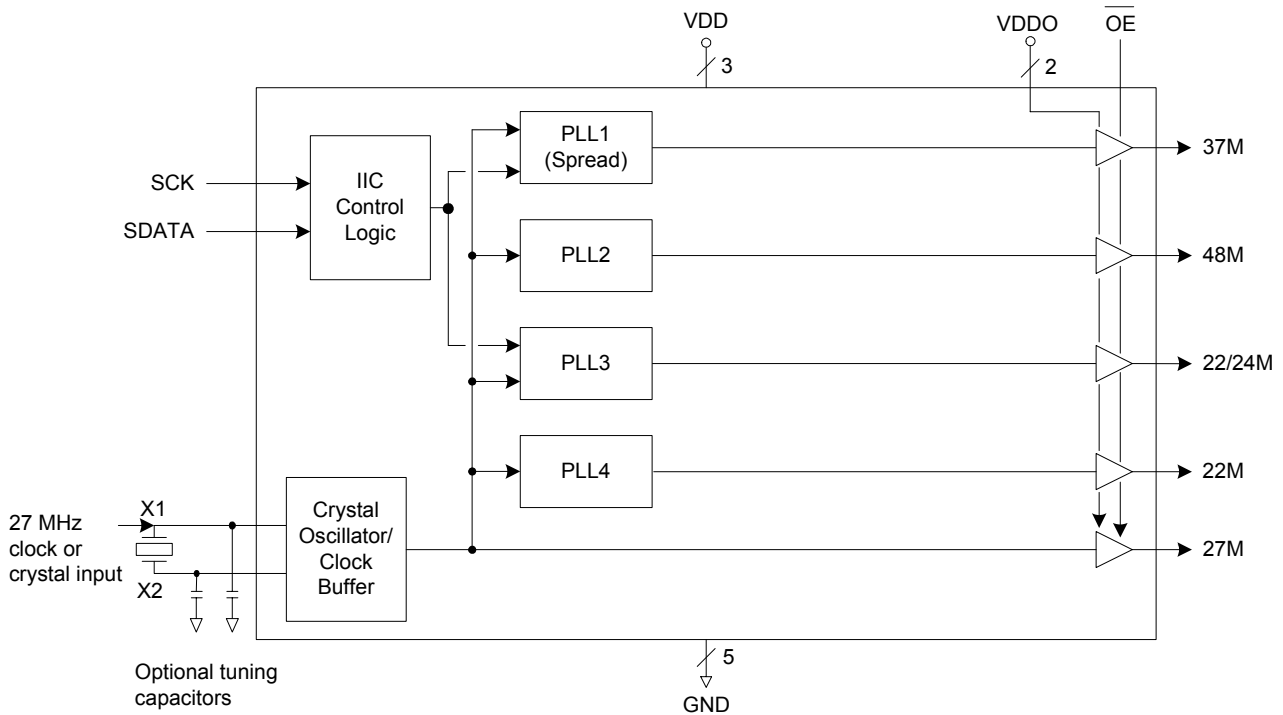

## Pin Assignment

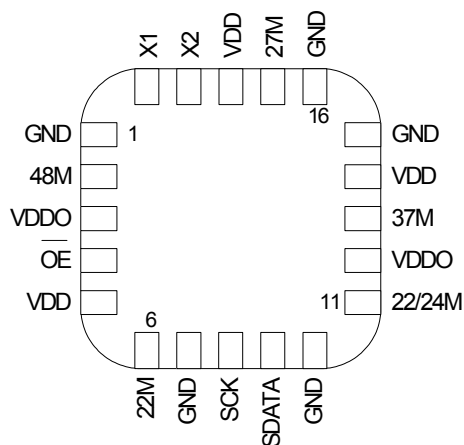

20-pin QFN

## Output Enable Table

$\overline{OE}$	Clock Output State
0	Normal Operation
1	Hi-Z

Note:  $\overline{OE}$  pin has an internal pull-down resistor.

## Pin Descriptions

Pin Number	Pin Name	Pin Type	Pin Description
1	GND	Power	Connect to ground.
2	48M	Output	48 MHz clock output. High impedance state when $\overline{OE}=1$ .
3	VDDO	Power	Output voltage level. Connect to +1.8 or 2.5 V. Same voltage as pin 12.
4	$\overline{OE}$	Input	Output Enable pin. See table above. Internal pull-down resistor.
5	VDD	Power	Connect to +1.8 V.
6	22M	Output	22.5792 MHz clock output. Internal pull-down. High impedance state when $\overline{OE}=1$ .
7	GND	Power	Connect to ground.
8	SCK	Input	I <sup>2</sup> C bus clock pin. Internal pull-up resistor.
9	SDATA	Input	I <sup>2</sup> C bus data pin. Internal pull-up resistor.
10	GND	Power	Connect to ground.
11	22/24M	Output	Selectable output clock of either 22.5792M or 24.576M. See table. Internal pull-down. High impedance state. $\overline{OE}=1$ .
12	VDDO	Power	Output voltage level. Connect to +1.8 or 2.5 V. Same voltage as pin 3.
13	37M	Output	Spread spectrum 37 MHz clock output. See table. Internal pull-down. High impedance state when $\overline{OE}=1$ .
14	VDD	Power	Connect to +1.8 V.
15	GND	Power	Connect to ground.
16	GND	Power	Connect to ground.
17	27M	Output	27 MHz reference clock output. Internal pull-down. High impedance state when $\overline{OE}=1$ .

Pin Number	Pin Name	Pin Type	Pin Description
18	VDD	Power	Connect to +1.8 V.
19	X2	Output	Connect to 27 MHz crystal or float for clock input.
20	X1	Input	Crystal connection. Connect to 27 MHz crystal or clock input.

## External Components

### Decoupling Capacitor

As with any high-performance mixed-signal IC, the ICS1493-17 must be isolated from system power supply noise to perform optimally.

A decoupling capacitor of 0.01 $\mu$ F must be connected between each VDD and the PCB ground plane.

### Series Termination Resistor

Clock output traces over one inch should use series termination. To series terminate a 50 $\Omega$  trace (a commonly used trace impedance), place a 33 $\Omega$  resistor in series with the clock line, as close to the clock output pin as possible. The nominal impedance of the clock output is 20 $\Omega$ .

### I<sup>2</sup>C External Resistor Connection

The SCK and SDATA pins can be connected to any voltage between 1.71 V and 2.625 V.

### Crystal Load Capacitors

No external crystal load capacitors are required. To save discrete component cost, the ICS1493-17 integrates on-chip capacitance to support a crystal with CL=10 pF. It is important to keep stray capacitance to a minimum by using very short PCB traces (and no vias) between the crystal and device.

### PCB Layout Recommendations

For optimum device performance and lowest output phase noise, the following guidelines should be observed.

- 1) The 0.01 $\mu$ F decoupling capacitors should be mounted on the component side of the board as close to the VDD pin as possible. No vias should be used between the decoupling capacitors and VDD pins. The PCB trace to VDD pins should be kept as short as possible, as should the PCB trace to the ground via.
- 2) The external crystal should be mounted just next to the device with short traces. The X1 and X2 traces should not be routed next to each other with minimum spaces, instead they should be separated and away from other traces.
- 3) To minimize EMI, the 33 $\Omega$  series termination resistor should be placed close to the clock output.
- 4) An optimum layout is one with all components on the same side of the board, minimizing vias through other signal layers. Other signal traces should be routed away from the ICS1493-17. This includes signal traces just underneath the device, or on layers adjacent to the ground plane layer used by the device.

## Absolute Maximum Ratings

Stresses above the ratings listed below can cause permanent damage to the ICS1493-17. These ratings, which are standard values for ICS commercially rated parts, are stress ratings only. Functional operation of the device at these or any other conditions above those indicated in the operational sections of the specifications is not implied. Exposure to absolute maximum rating conditions for extended periods can affect product reliability. Electrical parameters are guaranteed only over the recommended operating temperature range.

Item	Rating
Supply Voltage, VDD	-0.5 V to 5 V
All Inputs	-0.5 V to VDD+0.5 V
All Outputs	-0.5 V to 2.5V+0.5 V
Storage Temperature	-65 to +150°C
Junction Temperature	125°C
Soldering Temperature	260°C
ESD (HBM)	2000V min.
MSL (Moisture Sensitivity Level)	3

## Recommended Operation Conditions

Parameter	Min.	Typ.	Max.	Units
Ambient Operating Temperature	-10		+80	°C
Power Supply Voltage (measured in respect to GND)	+1.70		+2.00	V
Output Power Supply Voltage (with respect to GND)	+1.71		+2.625	V

## DC Electrical Characteristics

Unless stated otherwise, VDD = 1.8 V -0.1 V/+0.2 V, VDDO=2.5 V ±5%, Ambient Temp -10°C to +80°C

Parameter	Symbol	Conditions	Min.	Typ.	Max.	Units
Operating Voltage	VDD		1.7		2.0	V
Supply Current	IDD	No load, VDDO=2.5 V		13	16	mA
		No load, VDDO=1.8 V		11	15	mA
Input High Voltage	V <sub>IH</sub>		0.7VDD			V
Input Low Voltage	V <sub>IL</sub>				0.3VDD	V
Output High Voltage	V <sub>OH</sub>	I <sub>OH</sub> = -2 mA	0.8VDDO			V
Output Low Voltage	V <sub>OL</sub>	I <sub>OL</sub> = +2 mA			0.2VDDO	V
Input Capacitance, inputs	C <sub>IN</sub>			5		pF
Load Capacitance, X1 and X2	C <sub>L</sub>	No internal load capacitance		5		pF

Parameter	Symbol	Conditions	Min.	Typ.	Max.	Units
Internal Pull-down Resistor	R <sub>PD</sub>	$\overline{OE}$ , 48M, 22M, 22/24M, 37M, 27M	75	250		k $\Omega$
Internal Pull-up Resistor	R <sub>PU</sub>	SCK, SDATA	100	500		k $\Omega$

## AC Electrical Characteristics

Unless stated otherwise, **VDDO = 2.5 V  $\pm$ 5%**, Ambient Temperature -10°C to +80°C

Parameter	Symbol	Conditions	Min.	Typ.	Max.	Units
Input Frequency	f <sub>IN</sub>			27		MHz
Output Rise Time	t <sub>OR</sub>	20% to 80%, Note 1	0.7	1.5	2.2	ns
Output Fall Time	t <sub>OF</sub>	80% to 20%, Note 1	0.7	1.5	2.2	ns
Output Impedance	R <sub>O</sub>	VO=VDDO/2	33	46	68	$\Omega$
Output Clock Duty Cycle		VDDO/2, 27 MHz, Note 1	40	50	60	%
		VDDO/2, Note 1	45	50	55	%
Frequency Synthesis Error		All outputs		0		ppm
Modulation Rate			30	35	40	kHz
Short Term Jitter		Cycle-to-Cycle		150	300	ps
Long Term Jitter		27 MHz, n=1000			600	ps
Long Term Jitter		48 MHz, n=1000			800	ps
Long Term Jitter		22M and 22/24M, n=1000			1.2	ns
Long Term Jitter		37 MHz non-spread, n=1000		1.5	6	ns
Power-up Time	t <sub>PU</sub>	From minimum VDD to outputs stable		1.5	3	ms
Output Enable Time					50	ns
Output Disable Time					20	ns
Switching Time		22/24M, Note 2			100	ns

Note 1: Measured with a 5 pF load.

Note 2: Finish from prior cycle to start of new cycle.

## AC Electrical Characteristics

Unless stated otherwise,  $V_{DDO} = 1.8\text{ V} \pm 0.1\text{ V}$ , Ambient Temperature  $-10^{\circ}\text{C}$  to  $+80^{\circ}\text{C}$

Parameter	Symbol	Conditions	Min.	Typ.	Max.	Units
Input Frequency	$f_{IN}$			27		MHz
Output Rise Time	$t_{OR}$	20% to 80%, Note 1	1.1	2.2	3.3	ns
Output Fall Time	$t_{OF}$	80% to 20%, Note 1	1.1	2.2	3.3	ns
Output Impedance	$R_O$	$V_O = V_{DDO}/2$	33	46	68	$\Omega$
Output Clock Duty Cycle		$V_{DDO}/2$ , 27 MHz, Note 1	40	50	60	%
		$V_{DDO}/2$ , Note 1	45	50	55	%
Absolute Clock Period Jitter		Note 1		$\pm 225$		ps
Frequency Synthesis Error		All outputs		0		ppm
Modulation Rate			30	35	40	kHz
Short Term Jitter		Cycle-to-cycle		225	375	ps
Long Term Jitter		27 MHz, n=1000			900	ps
Long Term Jitter		48 MHz, n=1000			750	ps
Long Term Jitter		22M and 22/24M, n=1000			1200	ps
Long Term Jitter		37 MHz, n=1000		2.5	9	ns
Power-up Time	$t_{PU}$	From minimum VDD to outputs stable		1.5	4	ms
Output Enable Time					50	ns
Output Disable Time					20	ns
Switching Time		22/24M, Note 2			250	ns

Note 1: Measured with a 5 pF load.

Note 2: Finish from prior cycle to start of new cycle.

## Serial Data Interface

### Data Protocol

The clock driver serial protocol accepts byte write, byte read, block write, and block read operations from the controller. For block write/read operation, the bytes must be accessed in sequential order from lowest to highest byte (most significant bit first) with the ability to stop after any complete byte has been transferred. For byte write and byte read operations, the system controller can access individually indexed bytes. The offset of the indexed byte is encoded in the command code, as described in the following table.

Bit	Description
7	0 = Block read or block write operation, 1 = Byte read or byte write operation
(6:0)	Byte offset for byte read or byte write operation. For block read or block write operations, these bits should be '0000000'.

The block write and block read protocol is outlined in the table below, followed by the corresponding byte write and byte read protocol. The slave receiver address is 11010010 (D2h).

Block Write Protocol		Block Read Protocol	
Bit	Description	Bit	Description
1	Start	1	Start
2:8	Slave address - 7 bits	2:8	Slave address - 7 bits
9	Write = 0	9	Write = 0
10	Acknowledge from slave	10	Acknowledge from slave
11:18	Command code — 8 bit '00000000' stands for block operation	11:18	Command code - 8 bit '00000000' stands for block operation
19	Acknowledge from slave	19	Acknowledge from slave
20:27	Byte count — 8 bits	20	Repeat start
28	Acknowledge from slave	21:27	Slave address — 7 bits
29:36	Data byte 0 — 8 bits	28	Read = 1
37	Acknowledge from slave	29	Acknowledge from slave
38:45	Data byte 1 — 8 bits	30:37	Byte count from slave — 8 bits
46	Acknowledge from slave	38	Acknowledge from master
....	.....	39:46	Data byte from slave — 8 bits
....	Data byte (N-1) — 8 bits	47	Acknowledge from master
....	Acknowledge from slave	48:55	Data byte from slave — 8 bits
....	Data byte N — 8 bits	56	Acknowledge from master
....	Acknowledge from slave	....	Data byte N from slave — 8 bits
....	Stop	....	Not Acknowledge from master
		....	Stop

Byte Write Protocol		Byte Read Protocol	
Bit	Description	Bit	Description
1	Start	1	Start
2:8	Slave address - 7 bits	2:8	Slave address - 7 bits
9	Write = 0	9	Write = 0
10	Acknowledge from slave	10	Acknowledge from slave
11:18	Command code — 8 bit '10000000' stands for byte operation, bits[1:0] of the command code represents the offset of the byte to be accessed	11:18	Command code — 8 bit '10000000' stands for byte operation, bits[1:0] of the command code represents the offset of the byte to be accessed
19	Acknowledge from slave	19	Acknowledge from slave
20:27	Data byte from master— 8 bits	20	Repeat start
28	Acknowledge from slave	21:27	Slave address — 7 bits
29	Stop	28	Read = 1
		29	Acknowledge from slave
		30:37	Data byte from slave — 8 bits
		38	Not Acknowledge from master
		39	Stop

### Byte 0: Vendor ID, Revision Code

Bit	@Pup	Name	Description
7	0	Revision Code(MSB)	Revision Code
6	0	Revision Code	Revision Code
5	0	Revision Code	Revision Code
4	1	Revision Code(LSB)	Revision Code
3	1	Vendor ID(MSB)	Vendor ID
2	1	Vendor ID	Vendor ID
1	1	Vendor ID	Vendor ID
0	1	Vendor ID(LSB)	Vendor ID

**Byte 1: Control Register**

Bit	@Pup	Name	Description
7	1	REF	REF Output Enable 0 = Disable, Output pulled low, 1 = Enable
6	1	37SS	37SS Output Enable 0 = Disable, Output pulled low, corresponding PLL shut off. 1 = Enable
5	1	48M	48M Output Enable 0 = Disable, Output pulled low, 1 = Enable
4	1	22/24M	22/24M Clock Output Enable 0 = Disable, Output pulled low, 1 = Enable
3	0	22M	22M Output Enable 0 = Disable, Output pulled low and corresponding PLL off, 1 = Enable
2	1	Reserved	Reserved
1	1	Reserved	Reserved
0	1	22/24M SEL	22/24M Clock Select 1 = 24.576 MHz, 0 = 22.5792 MHz

**Byte 2: Control Register**

Bit	@Pup	Name	Description
7	0	Reserved	Reserved
6	0	Reserved	Reserved
5	0	Reserved	Reserved
4	0	Reserved	Reserved
3	0	Reserved	Reserved
2	0	SS Table	Bit 2:0=000: No Spread Bit 2:0=001: -0.5% Spread
1	1	SS Table	Bit 2:0=010: -1.0% Spread Bit 2:0=011: No Spread Bit 2:0=100: -2.0% Spread
0	0	SS Table	Bit 2:0=101: No Spread Bit 2:0=110: -3.0% Spread Bit 2:0=111: No Spread

## Thermal Characteristics

Parameter	Symbol	Conditions	Min.	Typ.	Max.	Units
Thermal Resistance Junction to Ambient	$\theta_{JA}$	Still air		39		°C/W
	$\theta_{JA}$	1 m/s air flow		36		°C/W
	$\theta_{JA}$	2.5 m/s air flow		34		°C/W

## Marking Diagram

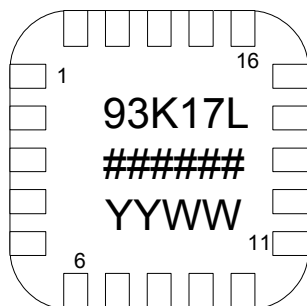

### Notes:

- ##### is the lot code.
- YYWW is the last two digits of the year and the week number that the part was assembled.
- “L” denotes Pb (lead) free package.
- Bottom marking: (origin). Origin = country of origin if not USA.

## Package Outline and Package Dimensions (20-pin QFN)

Package dimensions are kept current with JEDEC Publication No. 95

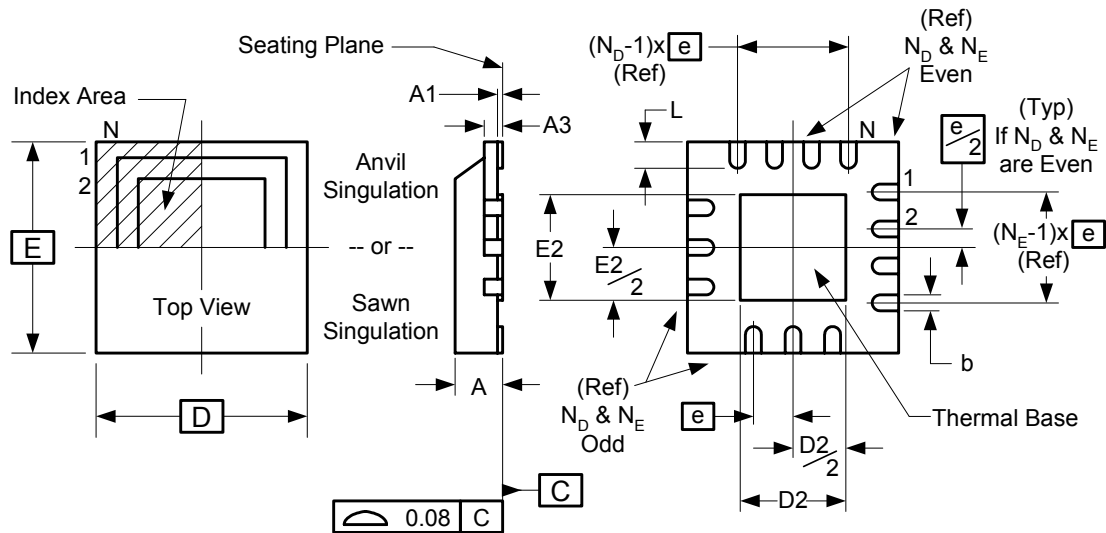

Symbol	Millimeters	
	Min	Max
A	0.80	1.00
A1	0	0.05
A3	0.20 Reference	
b	0.18	0.30
e	0.50 BASIC	
N	20	
ND	5	
NE	5	
D x E BASIC	4.00 x 4.00	
D2	1.95	2.25
E2	1.95	2.25
L	0.45	0.75

## Ordering Information

Part / Order Number	Marking	Shipping Packaging	Package	Temperature
ICS1493K-17LF	see page 10	Tubes	20-pin QFN	-10 to +80°C
ICS1493K-17LFT		Tape and Reel	20-pin QFN	-10 to +80°C

**Parts that are ordered with a "LF" suffix to the part number are the Pb-Free configuration and are RoHS compliant.**

While the information presented herein has been checked for both accuracy and reliability, Integrated Circuit Systems (ICS) assumes no responsibility for either its use or for the infringement of any patents or other rights of third parties, which would result from its use. No other circuits, patents, or licenses are implied. This product is intended for use in normal commercial applications. Any other applications such as those requiring extended temperature range, high reliability, or other extraordinary environmental requirements are not recommended without additional processing by ICS. ICS reserves the right to change any circuitry or specifications without notice. ICS does not authorize or warrant any ICS product for use in life support devices or critical medical instruments.



## IMPORTANT NOTICE AND DISCLAIMER

RENESAS ELECTRONICS CORPORATION AND ITS SUBSIDIARIES (“RENESAS”) PROVIDES TECHNICAL SPECIFICATIONS AND RELIABILITY DATA (INCLUDING DATASHEETS), DESIGN RESOURCES (INCLUDING REFERENCE DESIGNS), APPLICATION OR OTHER DESIGN ADVICE, WEB TOOLS, SAFETY INFORMATION, AND OTHER RESOURCES “AS IS” AND WITH ALL FAULTS, AND DISCLAIMS ALL WARRANTIES, EXPRESS OR IMPLIED, INCLUDING, WITHOUT LIMITATION, ANY IMPLIED WARRANTIES OF MERCHANTABILITY, FITNESS FOR A PARTICULAR PURPOSE, OR NON-INFRINGEMENT OF THIRD-PARTY INTELLECTUAL PROPERTY RIGHTS.

These resources are intended for developers who are designing with Renesas products. You are solely responsible for (1) selecting the appropriate products for your application, (2) designing, validating, and testing your application, and (3) ensuring your application meets applicable standards, and any other safety, security, or other requirements. These resources are subject to change without notice. Renesas grants you permission to use these resources only to develop an application that uses Renesas products. Other reproduction or use of these resources is strictly prohibited. No license is granted to any other Renesas intellectual property or to any third-party intellectual property. Renesas disclaims responsibility for, and you will fully indemnify Renesas and its representatives against, any claims, damages, costs, losses, or liabilities arising from your use of these resources. Renesas' products are provided only subject to Renesas' Terms and Conditions of Sale or other applicable terms agreed to in writing. No use of any Renesas resources expands or otherwise alters any applicable warranties or warranty disclaimers for these products.

(Disclaimer Rev.1.01 Jan 2024)

### Corporate Headquarters

TOYOSU FORESIA, 3-2-24 Toyosu,  
Koto-ku, Tokyo 135-0061, Japan  
[www.renesas.com](http://www.renesas.com)

### Trademarks

Renesas and the Renesas logo are trademarks of Renesas Electronics Corporation. All trademarks and registered trademarks are the property of their respective owners.

### Contact Information

For further information on a product, technology, the most up-to-date version of a document, or your nearest sales office, please visit [www.renesas.com/contact-us/](http://www.renesas.com/contact-us/).

## Looking for pricing, stock, or lifecycle information?

Click below to explore more details on WIN SOURCE:

- ⊖ [View 1493K-17LFT on WIN SOURCE](#)
- ⊖ [Renesas Electronics America](#) Information

## Optimize Your Supply Chain with WIN SOURCE Solutions

- ✓ Global Sourcing Solution
- ✓ Obsolete Management
- ✓ Cost Control Management
- ✓ Shortage Management
- ✓ Alternative Solution
- ✓ Excess Inventory Management