

Description

The [SiT9366](#) is a 1 MHz to 220 MHz differential MEMS XO engineered for low-jitter applications. Utilizing SiTime's unique DualMEMS® temperature sensing and TurboCompensation® technology, the SiT9366 delivers exceptional dynamic performance by providing resistance to airflow, thermal gradients, shock and vibration. This device also integrates multiple on-chip regulators to filter power supply noise, eliminating the need for a dedicated external LDO.

The SiT9366 can be factory programmed for any combination of frequency, stability, voltage, and output signaling. Programmability enables designers to optimize clock configurations while eliminating long lead times and customization costs associated with quartz devices where each frequency is custom built.

The wide frequency range and programmability makes this device ideal for telecom, networking, and industrial applications that require a variety of frequencies and operate in noisy environments.

Refer to [Manufacturing Notes](#) for proper reflow profile, tape and reel dimension, and other manufacturing related information.

Features

- Any frequency between 1 MHz and 220 MHz accurate to 6 decimal places
(For additional frequencies, refer to [SiT9367](#) and [SiT9365](#) datasheets)
- LVPECL, Low-swing LVPECL, LVDS and HCSL output signaling
- 0.1 ps RMS phase jitter (random) for Ethernet applications
- Frequency stability as low ± 10 ppm
- Wide temperature ranges from -40°C to 105°C
- Industry-standard packages: $7.0 \times 5.0 \text{ mm}^2$, $5.0 \times 3.2 \text{ mm}^2$, $3.2 \times 2.5 \text{ mm}^2$ packages

Applications

- 10/40/100 Gbps Ethernet, SONET, SATA, SAS, Fibre Channel
- Telecom, networking, instrumentation, storage, servers

Related products for [automotive applications](#).

For aerospace and defense applications SiTime recommends using only [Endura™ SiT9346](#).



Order samples



Buy at SiTimeDirect



Green solutions



Lifetime warranty

Block Diagram

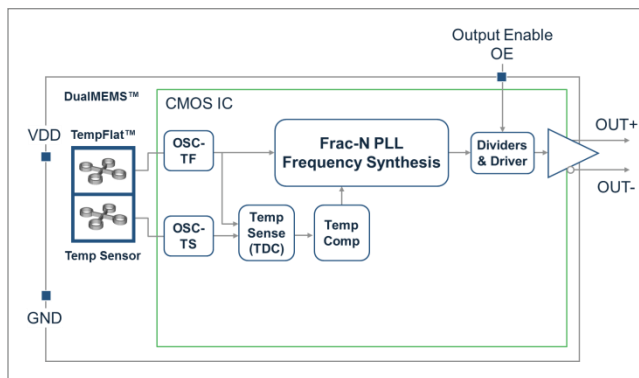

Figure 1. SiT9366 Block Diagram

Package Pinout

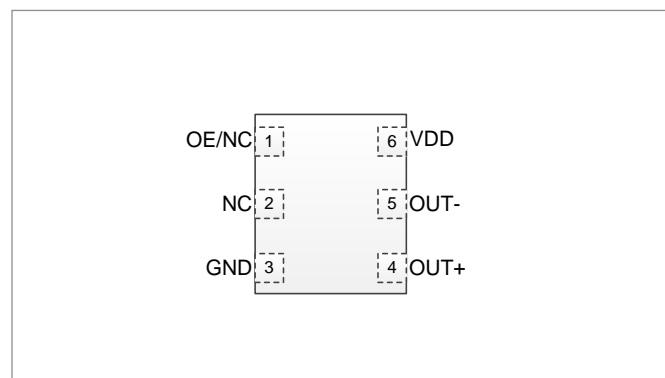
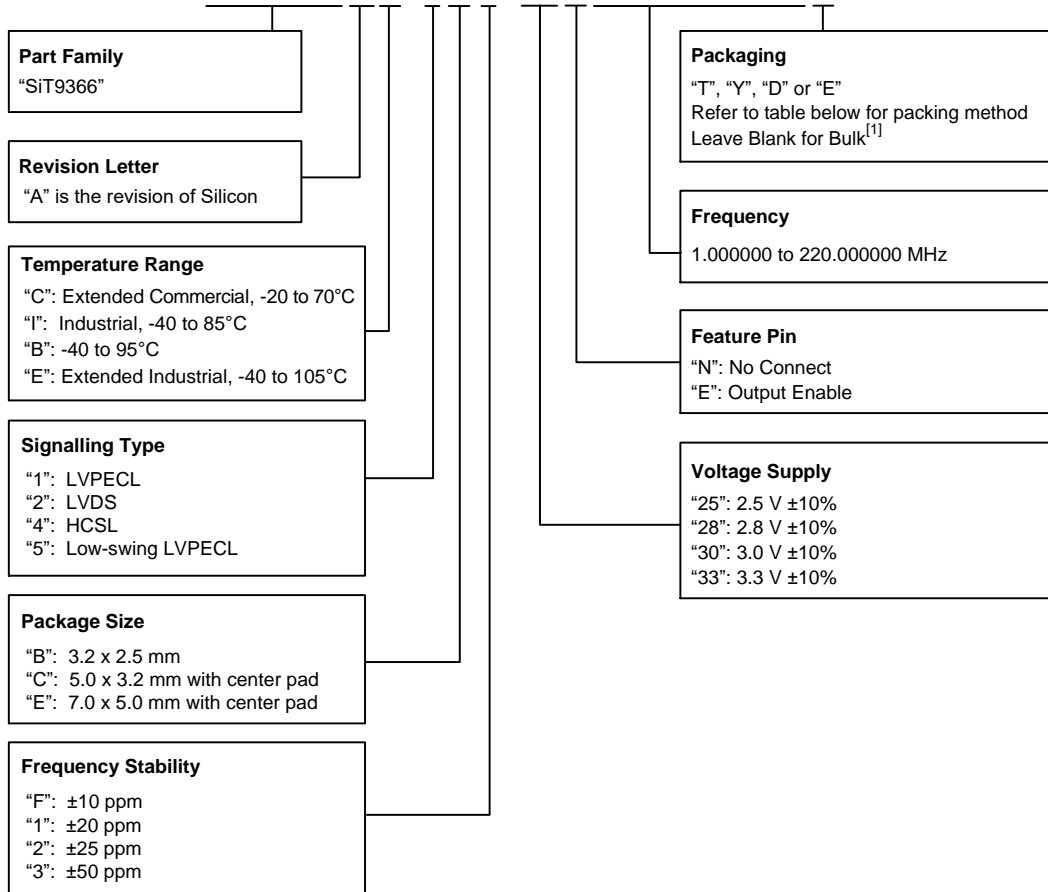

Figure 2. Pin Assignments (Top view)
(Refer to [Table 6](#) for Pin Descriptions)

Ordering Information

SiT9366AC-1B2-33E125.000000T



Notes:

- 1. Bulk is available for sampling only

Table 1. Ordering Codes for Supported Tape & Reel Packing Method

Device Size (mm x mm)	8 mm T&R (3ku)	8 mm T&R (1ku)	12 mm T&R (3ku)	12 mm T&R (1ku)	16 mm T&R (3ku)	16 mm T&R (1ku)
7.0 x 5.0	—	—	—	—	T	Y
5.0 x 3.2			T	Y		
3.2 x 2.5	D	E			—	—

TABLE OF CONTENTS

Description 1

Features 1

Applications 1

Block Diagram 1

Package Pinout 1

Ordering Information 2

Electrical Characteristics 4

Waveform Diagrams 9

Timing Diagrams 10

Termination Diagrams 11

 LVPECL and Low-swing LVPECL 11

 LVDS 12

 HCSL 12

Dimensions and Patterns — 3.2 x 2.5 mm² 13

Dimensions and Patterns — 5.0 x 3.2 mm² 13

Dimensions and Patterns — 7.0 x 5.0 mm² 14

Additional Information 15

Revision History 16

Electrical Characteristics

All Min and Max limits in the Electrical Characteristics tables are specified over temperature and rated operating voltage with standard output termination show in the termination diagrams. Typical values are at 25°C and nominal supply voltage.

Table 2. Electrical Characteristics – Common to LVPECL, Low-swing LVPECL, LVDS and HCSL (All temperature ranges)

Parameter	Symbol	Min.	Typ.	Max.	Unit	Condition
Frequency Range						
Output Frequency Range	f	1	–	220.000001	MHz	Accurate to 6 decimal places
Frequency Stability						
Frequency Stability	F_stab	-10	–	+10	ppm	Inclusive of initial tolerance, operating temperature, rated power supply voltage and load variations
		-20	–	+20	ppm	
		-25	–	+25	ppm	
		-50	–	+50	ppm	
First Year Aging	F_1y	-0.7	±0.4	+0.7	ppm	At 85°C
5 Year Aging	F_5y	-1.1	±0.7	+1.1	ppm	At 85°C
10 Year Aging	F_10y	-1.3	±0.8	+1.3	ppm	At 85°C
20 Year Aging	F_20y	-1.5	±1.0	+1.5	ppm	At 85°C
Temperature Range						
Operating Temperature Range	T_use	-20	–	+70	°C	Extended Commercial
		-40	–	+85	°C	Industrial
		-40	–	+95	°C	
		-40	–	+105	°C	Extended Industrial
Supply Voltage						
Supply Voltage	Vdd	2.97	3.30	3.63	V	
		2.70	3.00	3.30	V	
		2.52	2.80	3.08	V	
		2.25	2.50	2.75	V	
Input Characteristics						
Input Voltage High	VIH	70%	–	–	Vdd	Pin 1, OE
Input Voltage Low	VIL	–	–	30%	Vdd	Pin 1, OE
Input Pull-up Impedance	Z_in	–	100	–	kΩ	Pin 1, OE logic high or logic low
Output Characteristics						
Duty Cycle	DC	45	–	55	%	
Startup and OE Timing						
Startup Time	T_start	–	–	3.0	ms	Measured from the time Vdd reaches its rated minimum value.
OE Enable/Disable Time	T_oe	–	–	3.8	μs	f = 156.25 MHz. Measured from the time OE pin reaches rated VIH and VIL to the time clock pins reach 90% of swing and high-Z. See Figure 8 and Figure 9 .

Table 3. Electrical Characteristics – LVPECL, Low-swing LVPECL

Parameter	Symbol	Min.	Typ.	Max.	Unit	Condition
Current Consumption						
Current Consumption	I _{dd}	–	–	89	mA	Excluding Load Termination Current, V _{dd} = 3.3 V or 2.5 V
OE Disable Supply Current	I _{OE}	–	–	58	mA	OE = Low
Output Disable Leakage Current	I _{leak}	–	0.15	–	μA	OE = Low
Maximum Output Current	I _{driver}	–	–	32	mA	Maximum average current drawn from OUT+ or OUT-
Output Characteristics for LVPECL						
Output High Voltage	VOH	V _{dd} -1.1	–	V _{dd} -0.7	V	See Figure 4
Output Low Voltage	VOL	V _{dd} -1.9	–	V _{dd} -1.5	V	See Figure 4
Output Differential Voltage Swing	V _{Swing}	1.2	1.6	2.0	V	See Figure 5
Rise/Fall Time	T _r , T _f	–	225	290	ps	20% to 80%, See Figure 5
Output Characteristics for Low-swing LVPECL						
Output High Voltage	VOH	V _{dd} -1.2	–	V _{dd} -0.75	V	See Figure 4
Output Low Voltage	VOL	V _{dd} -1.8	–	V _{dd} -1.25	V	See Figure 4
Output Differential Voltage Swing	V _{Swing}	0.4	1	1.2	V	Output frequency 1 to 220 MHz, See Figure 5
		0.4	1	1.6	V	Output frequency greater than 220 MHz, See Figure 5
Rise/Fall Time	T _r , T _f	–	225	290	ps	20% to 80%. See Figure 5
Jitter – 7.0 x 5.0 mm Package						
RMS Period Jitter ^[2]	T _{jitt}	–	1.0	1.6	ps	f = 100, 156.25 or 212.5 MHz, V _{dd} = 3.3 V or 2.5 V
RMS Phase Jitter (random)	T _{phj}	–	0.225	0.270	ps	f = 156.25 MHz, Integration bandwidth = 12 kHz to 20 MHz, all V _{dd} levels, includes spurs. Temperature ranges -20 to 70°C and -40 to 85°C
		–	0.225	0.300	ps	f = 156.25 MHz, Integration bandwidth = 12 kHz to 20 MHz, all V _{dd} levels, includes spurs. Temperature ranges -40 to 95°C and -40 to 105°C
		–	0.1	–	ps	f = 156.25 or 322.265625 MHz, IEEE802.3-2005 10GbE jitter mask integration bandwidth = 1.875 MHz to 20 MHz, includes spurs, all V _{dd} levels.
Jitter – 5.0 x 3.2 and 3.2 x 2.5 mm Packages						
RMS Period Jitter ^[2]	T _{jitt}	–	1.0	1.6	ps	f = 100, 156.25 or 212.5 MHz, V _{dd} = 3.3 V or 2.5 V
RMS Phase Jitter (random)		–	0.225	0.275	ps	f = 156.25 MHz, Integration bandwidth = 12 kHz to 20 MHz, all V _{dd} levels, includes spurs. Temperature ranges -20 to 70°C and -40 to 85°C
		–	0.225	0.340	ps	f = 156.25 MHz, Integration bandwidth = 12 kHz to 20 MHz, all V _{dd} levels, includes spurs. Temperature ranges -40 to 95°C and -40 to 105°C
		–	0.1	–	ps	f = 156.25 or 322.265625 MHz, IEEE802.3-2005 10GbE jitter mask integration bandwidth = 1.875 MHz to 20 MHz, includes spurs, all V _{dd} levels.

Notes:

2. Measured according to JESD65B.

Table 4. Electrical Characteristics – LVDS

Parameter	Symbol	Min.	Typ.	Max.	Unit	Condition
Current Consumption						
Current Consumption	I _{dd}	–	–	79	mA	Excluding Load Termination Current, V _{dd} = 3.3 V or 2.5 V
OE Disable Supply Current	I _{OE}	–	–	58	mA	OE = Low
Output Disable Leakage Current	I _{leak}	–	0.15	–	μA	OE = Low
Output Characteristics						
Differential Output Voltage	V _{OD}	300	–	450	mV	See Figure 6
Delta VOD	ΔV _{OD}	–	–	50	mV	See Figure 6
Offset Voltage	V _{OS}	1.125	–	1.375	V	See Figure 6
Delta VOS	ΔV _{OS}	–	–	50	mV	See Figure 6
Rise/Fall Time	T _r , T _f	–	400	470	ps	Measured with 2 pF capacitive loading to GND, 20% to 80%, see Figure 7
Jitter – 7.0 x 5.0 mm Package						
RMS Period Jitter^[3]	T _{jitt}	–	1.0	1.6	ps	f = 100, 156.25 or 212.5 MHz, V _{dd} = 3.3 V or 2.5 V
RMS Phase Jitter (random)	T _{phj}	–	0.215	0.265	ps	f = 156.25 MHz, Integration bandwidth = 12 kHz to 20 MHz, all V _{dd} levels, includes spurs. Temperature ranges -20 to 70°C and -40 to 85°C
		–	0.215	0.300	ps	f = 156.25 MHz, Integration bandwidth = 12 kHz to 20 MHz, all V _{dd} levels, includes spurs. Temperature ranges -40 to 95°C and -40 to 105°C
		–	0.1	–	ps	f = 156.25 or 322.265625 MHz, IEEE802.3-2005 10GbE jitter mask integration bandwidth = 1.875 MHz to 20 MHz, includes spurs, all V _{dd} levels.
Jitter – 5.0 x 3.2 and 3.2 x 2.5 mm Packages						
RMS Period Jitter^[3]	T _{jitt}	–	1.0	1.6	ps	f = 100, 156.25 or 212.5 MHz, V _{dd} = 3.3 V or 2.5 V
RMS Phase Jitter (random)	T _{phj}	–	0.235	0.275	ps	f = 156.25 MHz, Integration bandwidth = 12 kHz to 20 MHz, all V _{dd} levels, includes spurs. Temperature ranges -20 to 70°C and -40 to 85°C
		–	0.235	0.320	ps	f = 156.25 MHz, Integration bandwidth = 12 kHz to 20 MHz, all V _{dd} levels, includes spurs. Temperature ranges -40 to 95°C and -40 to 105°C
		–	0.1	–	ps	f = 156.25 or 322.265625 MHz, IEEE802.3-2005 10GbE jitter mask integration bandwidth = 1.875 MHz to 20 MHz, includes spurs, all V _{dd} levels.

Notes:

- Measured according to JESD65B.

Table 5. Electrical Characteristics – HCSL

Parameter	Symbol	Min.	Typ.	Max.	Unit	Condition
Current Consumption						
Current Consumption	I _{dd}	–	–	89	mA	Excluding Load Termination Current, V _{dd} = 3.3 V or 2.5 V
OE Disable Supply Current	I _{OE}	–	–	58	mA	OE = Low
Output Disable Leakage Current	I _{leak}	–	0.15	–	μA	OE = Low
Maximum Output Current	I _{driver}	–	–	35	mA	Maximum average current drawn from OUT+ or OUT-
Output Characteristics						
Output High Voltage	VOH	0.60	–	0.90	V	See Figure 4
Output Low Voltage	VOL	-0.05	–	0.08	V	See Figure 4
Output Differential Voltage Swing	V _{Swing}	1.2	1.4	1.80	V	See Figure 5
Rise/Fall Time	Tr, Tf	–	360	465	ps	Measured with 2 pF capacitive loading to GND, 20% to 80%, see Figure 5
Jitter – 7.0 x 5.0 mm Package						
RMS Period Jitter^[3]	T _{jitt}	–	1.0	1.6	ps	f = 100, 156.25 or 212.5 MHz, V _{dd} = 3.3 V or 2.5 V
RMS Phase Jitter (random)	T _{phj}	–	0.220	0.270	ps	f = 156.25 MHz, Integration bandwidth = 12 kHz to 20 MHz, all V _{dd} levels, includes spurs. Temperature ranges -20 to 70°C and -40 to 85°C
		–	0.220	0.300	ps	f = 156.25 MHz, Integration bandwidth = 12 kHz to 20 MHz, all V _{dd} levels, includes spurs. Temperature ranges -40 to 95°C and -40 to 105°C
		–	0.1	–	ps	f = 156.25 or 322.265625 MHz, IEEE802.3-2005 10GbE jitter mask integration bandwidth = 1.875 MHz to 20 MHz, includes spurs, all V _{dd} levels.
Jitter – 5.0 x 3.2 and 3.2 x 2.5 mm Packages						
RMS Period Jitter^[4]	T _{jitt}	–	1.0	1.6	ps	f = 100, 156.25 or 212.5 MHz, V _{dd} = 3.3 V or 2.5 V
RMS Phase Jitter (random)	T _{phj}	–	0.230	0.275	ps	f = 156.25 MHz, Integration bandwidth = 12 kHz to 20 MHz, all V _{dd} levels, includes spurs. Temperature ranges -20 to 70°C and -40 to 85°C
		–	0.230	0.340	ps	f = 156.25 MHz, Integration bandwidth = 12 kHz to 20 MHz, all V _{dd} levels, includes spurs. Temperature ranges -40 to 95°C and -40 to 105°C
		–	0.1	–	ps	f = 156.25 or 322.265625 MHz, IEEE802.3-2005 10GbE jitter mask integration bandwidth = 1.875 MHz to 20 MHz, includes spurs, all V _{dd} levels.

Notes:

4. Measured according to JESD65B.

Table 6. Pin Description

Pin	Map	Functionality	
1	OE/NC	Output Enable (OE)	H ^[5] : specified frequency output L: output is high impedance
		Non Connect (NC)	H or L or Open: No effect on output frequency or other device functions
2	NC	NA	No Connect; Leave it floating or connect to GND for better heat dissipation
3	GND	Power	V _{dd} Power Supply Ground
4	OUT+	Output	Oscillator output
5	OUT-	Output	Complementary oscillator output
6	V _{dd}	Power	Power supply voltage ^[6]

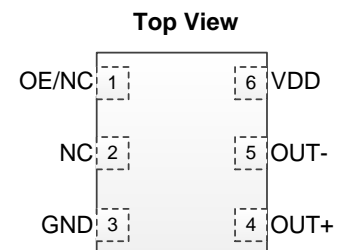

Figure 3. Pin Assignments

Notes:

5. In OE mode, a pull-up resistor of 10 kΩ or less is recommended if pin 1 is not externally driven.

6. A capacitor of value 0.1 μF or higher between V_{DD} and GND is required. An additional 10 μF capacitor between V_{DD} and GND is required for the best phase jitter performance.

Table 7. Absolute Maximum Ratings

Attempted operation outside the absolute maximum ratings may cause permanent damage to the part. Actual performance of the IC is only guaranteed within the operational specifications, not at absolute maximum ratings.

Parameter	Min.	Max.	Unit
Vdd	-0.5	4.0	V
VIH		Vdd + 0.3V	V
VIL	-0.3		V
Storage Temperature	-65	150	°C
Maximum Junction Temperature		130	°C
Soldering Temperature (follow standard Pb-free soldering guidelines)		260	°C

Table 8. Thermal Considerations^[7]

Package	θ_{JA} , 4 Layer Board (°C/W)	θ_{JC} , Bottom (°C/W)
3225, 6-pin	80	30
5032, 6-pin	53	20
7050, 6-pin	52	19

Notes:

7. Refer to JESD51 for θ_{JA} and θ_{JC} definitions, and reference layout used to determine the θ_{JA} and θ_{JC} values in the above table.

Table 9. Maximum Operating Junction Temperature^[8]

Max Operating Temperature (ambient)	Maximum Operating Junction Temperature
70°C	95°C
85°C	110°C
95°C	120°C
105°C	130°C

Notes:

8. Datasheet specifications are not guaranteed if junction temperature exceeds the maximum operating junction temperature.

Table 10. Environmental Compliance

Parameter	Test Conditions	Value	Unit
Mechanical Shock Resistance	MIL-STD-883F, Method 2002	10,000	G
Mechanical Vibration Resistance	MIL-STD-883F, Method 2007	70	G
Soldering Temperature (follow standard Pb free soldering guidelines)	MIL-STD-883F, Method 2003	260	°C
Moisture Sensitivity Level	MSL1 @ 260°C		
Electrostatic Discharge (HBM)	HBM, JESD22-A114	2,000	V
Charge-Device Model ESD Protection	JESD220C101	750	V
Latch-up Tolerance	JESD78 Compliant		

Waveform Diagrams

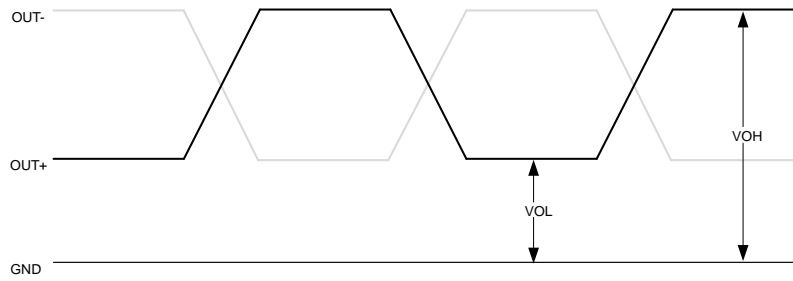

Figure 4. LVPECL, Low-swing LVPECL, and HCSL Voltage Levels per Differential Pin (i.e. OUT+, or OUT-)

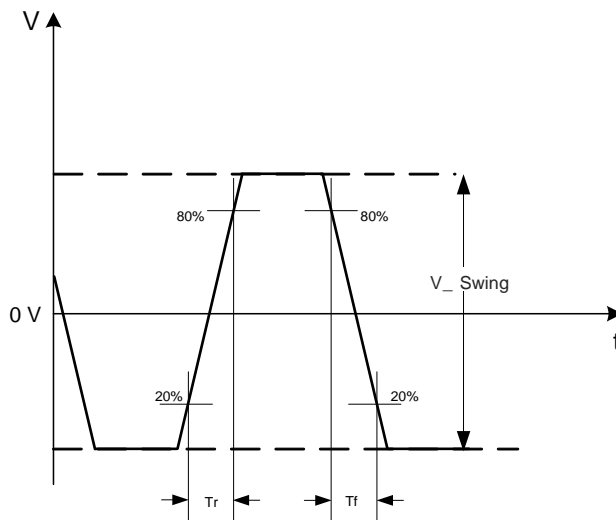

Figure 5. LVPECL, Low-swing LVPECL, and HCSL Voltage Levels Across Differential Pair (i.e. OUT+ minus OUT-)

Waveform Diagrams (continued)

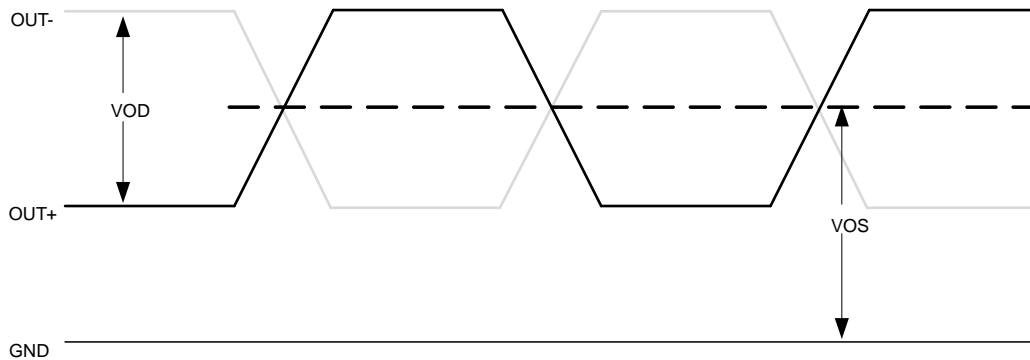

Figure 6. LVDS Voltage Levels per Differential Pin (i.e. OUT+, or OUT-)

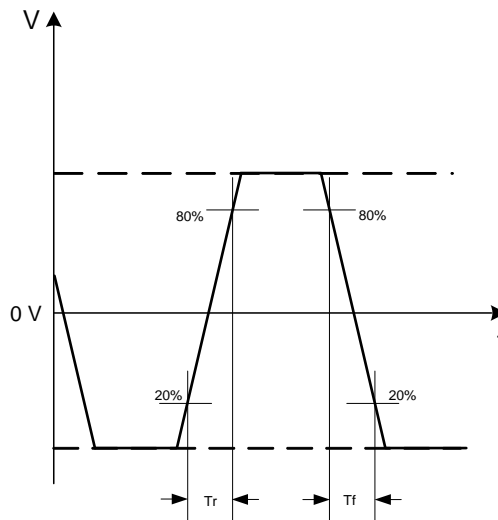

Figure 7. LVDS Differential Waveform (i.e. OUT+ minus OUT-)

Timing Diagrams

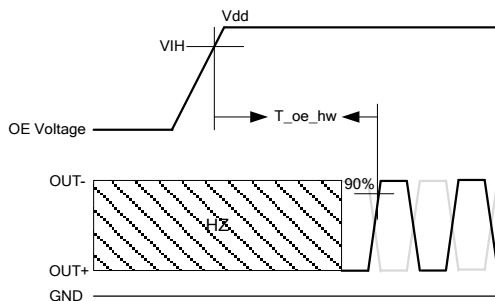

Figure 8. Hardware OE Enable Timing

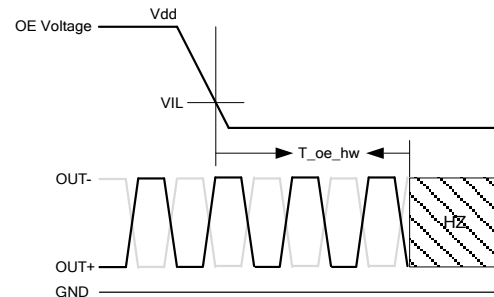

Figure 9. Hardware OE Disable Timing

Termination Diagrams

LVPECL and Low-swing LVPECL

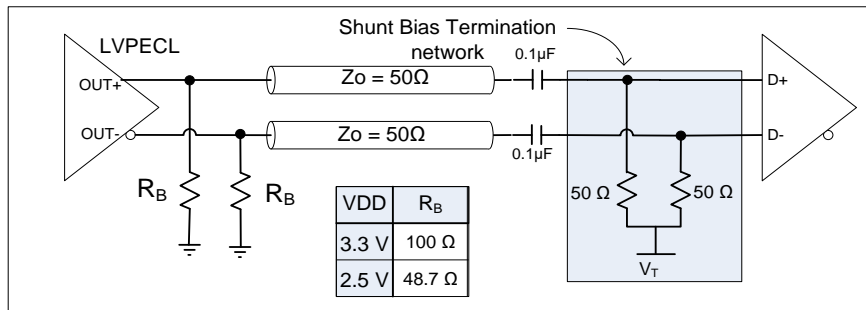

Figure 10. LVPECL and Low-swing LVPECL with AC-coupled Termination

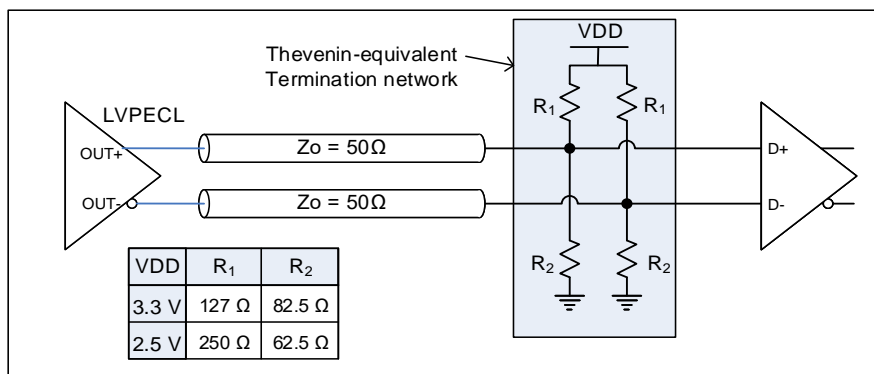

Figure 11. LVPECL and Low-swing LVPECL DC-coupled Load Termination with Thevenin Equivalent Network

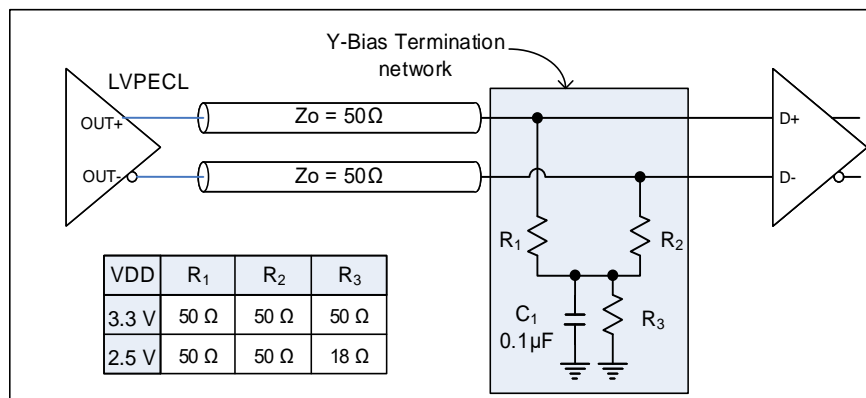

Figure 12. LVPECL and Low-swing LVPECL with Y-Bias Termination

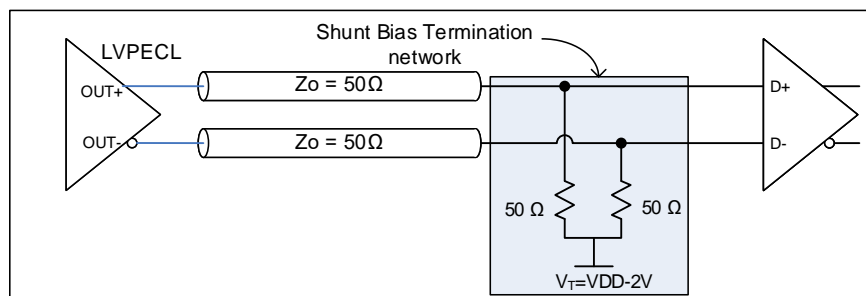

Figure 13. LVPECL and Low-swing LVPECL with DC-coupled Parallel Shunt Load Termination

Termination Diagrams (continued)

LVDS

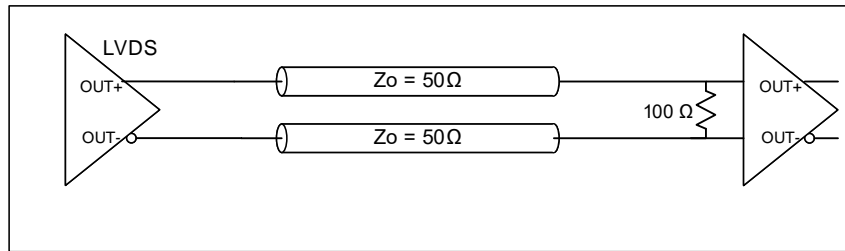

Figure 14. LVDS single DC Termination at the Load

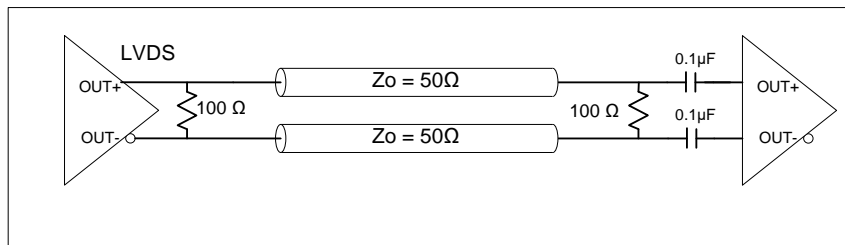

Figure 15. LVDS Double AC Termination with Capacitor Close to the Load

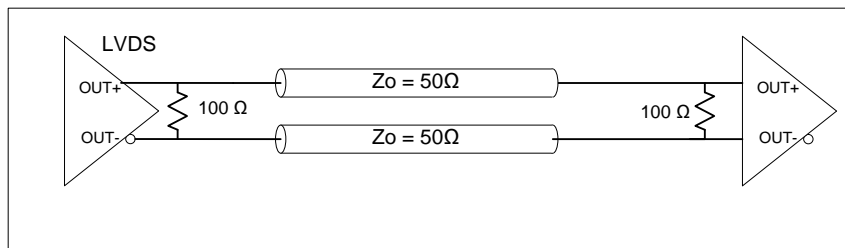

Figure 16. LVDS Double DC Termination

HCSL

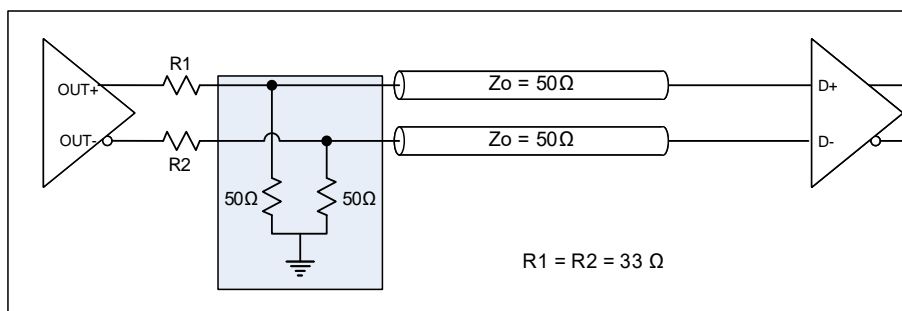

Figure 17. HCSL Interface Termination

Dimensions and Patterns — 3.2 x 2.5 mm²

Package Size – Dimensions (Unit: mm) ^[9]	Recommended Land Pattern (Unit: mm) ^[10]																																																																																	
<p>3.2 x 2.5 x 0.85 mm</p> <table border="1" style="width: 100%; border-collapse: collapse; margin-top: 10px;"> <thead> <tr> <th></th> <th>SYMBOL</th> <th>MIN</th> <th>NOM</th> <th>MAX</th> </tr> </thead> <tbody> <tr> <td>TOTAL THICKNESS</td> <td>A</td> <td>0.800</td> <td>0.850</td> <td>0.900</td> </tr> <tr> <td>STAND OFF</td> <td>A1</td> <td>0.000</td> <td>0.035</td> <td>0.050</td> </tr> <tr> <td rowspan="2">BODY SIZE</td> <td>X</td> <td>D</td> <td>3.200 BSC</td> <td></td> </tr> <tr> <td>Y</td> <td>E</td> <td>2.500 BSC</td> <td></td> </tr> <tr> <td rowspan="2">LEAD WIDTH</td> <td>b</td> <td>0.550</td> <td>0.600</td> <td>0.650</td> </tr> <tr> <td>L</td> <td>0.650</td> <td>0.700</td> <td>0.750</td> </tr> <tr> <td>LEAD LENGTH</td> <td>L1</td> <td>0.800 REF</td> <td></td> <td></td> </tr> <tr> <td>LEAD PITCH</td> <td>e</td> <td>1.100 BSC</td> <td></td> <td></td> </tr> <tr> <td>PACKAGE TOLERANCE</td> <td>aaa</td> <td>0.100</td> <td></td> <td></td> </tr> <tr> <td>MOLD FLATNESS</td> <td>bbb</td> <td>0.100</td> <td></td> <td></td> </tr> <tr> <td>COPLANARITY</td> <td>ccc</td> <td>0.080</td> <td></td> <td></td> </tr> <tr> <td>DIMPLE WIDTH</td> <td>T</td> <td>0.150 REF</td> <td></td> <td></td> </tr> <tr> <td>DIMPLE LENGTH</td> <td>P</td> <td>0.150 REF</td> <td></td> <td></td> </tr> <tr> <td>DIMPLE DEPTH</td> <td>A2</td> <td>0.100 REF</td> <td></td> <td></td> </tr> </tbody> </table> <p>Notes: 1. All dimensions are in millimeters</p> <table border="1" style="width: 100%; border-collapse: collapse; margin-top: 10px;"> <thead> <tr> <th colspan="2" style="text-align: center;">Package Outline</th> </tr> </thead> <tbody> <tr> <td style="text-align: center;">6L PQFD</td> <td style="text-align: center;">POD-038-PQFD-004-C03225</td> </tr> <tr> <td colspan="2" style="text-align: center;">3.200x2.500x0.850 mm</td> </tr> <tr> <td colspan="2" style="text-align: center;">2021/07/15 Rev C00 </td> </tr> </tbody> </table>		SYMBOL	MIN	NOM	MAX	TOTAL THICKNESS	A	0.800	0.850	0.900	STAND OFF	A1	0.000	0.035	0.050	BODY SIZE	X	D	3.200 BSC		Y	E	2.500 BSC		LEAD WIDTH	b	0.550	0.600	0.650	L	0.650	0.700	0.750	LEAD LENGTH	L1	0.800 REF			LEAD PITCH	e	1.100 BSC			PACKAGE TOLERANCE	aaa	0.100			MOLD FLATNESS	bbb	0.100			COPLANARITY	ccc	0.080			DIMPLE WIDTH	T	0.150 REF			DIMPLE LENGTH	P	0.150 REF			DIMPLE DEPTH	A2	0.100 REF			Package Outline		6L PQFD	POD-038-PQFD-004-C03225	3.200x2.500x0.850 mm		2021/07/15 Rev C00		<p>3.2 x 2.5 x 0.85 mm</p>
	SYMBOL	MIN	NOM	MAX																																																																														
TOTAL THICKNESS	A	0.800	0.850	0.900																																																																														
STAND OFF	A1	0.000	0.035	0.050																																																																														
BODY SIZE	X	D	3.200 BSC																																																																															
	Y	E	2.500 BSC																																																																															
LEAD WIDTH	b	0.550	0.600	0.650																																																																														
	L	0.650	0.700	0.750																																																																														
LEAD LENGTH	L1	0.800 REF																																																																																
LEAD PITCH	e	1.100 BSC																																																																																
PACKAGE TOLERANCE	aaa	0.100																																																																																
MOLD FLATNESS	bbb	0.100																																																																																
COPLANARITY	ccc	0.080																																																																																
DIMPLE WIDTH	T	0.150 REF																																																																																
DIMPLE LENGTH	P	0.150 REF																																																																																
DIMPLE DEPTH	A2	0.100 REF																																																																																
Package Outline																																																																																		
6L PQFD	POD-038-PQFD-004-C03225																																																																																	
3.200x2.500x0.850 mm																																																																																		
2021/07/15 Rev C00																																																																																		

Dimensions and Patterns — 5.0 x 3.2 mm²

Package Size – Dimensions (Unit: mm) ^[9]	Recommended Land Pattern (Unit: mm) ^[10]																																																																																												
<p>5.0 x 3.2 x 0.85 mm^[11]</p> <table border="1" style="width: 100%; border-collapse: collapse; margin-top: 10px;"> <thead> <tr> <th></th> <th>SYMBOL</th> <th>MIN</th> <th>NOM</th> <th>MAX</th> </tr> </thead> <tbody> <tr> <td>TOTAL THICKNESS</td> <td>A</td> <td>0.800</td> <td>0.850</td> <td>0.900</td> </tr> <tr> <td>STAND OFF</td> <td>A1</td> <td>0.000</td> <td>0.035</td> <td>0.050</td> </tr> <tr> <td rowspan="2">BODY SIZE</td> <td>X</td> <td>D</td> <td>5.000 BSC</td> <td></td> </tr> <tr> <td>Y</td> <td>E</td> <td>3.200 BSC</td> <td></td> </tr> <tr> <td rowspan="2">EP SIZE</td> <td>X</td> <td>J</td> <td>3.100</td> <td>3.200</td> <td>3.300</td> </tr> <tr> <td>Y</td> <td>K</td> <td>0.500</td> <td>0.600</td> <td>0.700</td> </tr> <tr> <td rowspan="2">LEAD WIDTH</td> <td>b</td> <td>0.590</td> <td>0.640</td> <td>0.690</td> </tr> <tr> <td>L</td> <td>0.850</td> <td>0.900</td> <td>0.950</td> </tr> <tr> <td>LEAD LENGTH</td> <td>L1</td> <td>1.000 REF</td> <td></td> <td></td> </tr> <tr> <td>LEAD PITCH</td> <td>e</td> <td>1.270 BSC</td> <td></td> <td></td> </tr> <tr> <td>PACKAGE TOLERANCE</td> <td>aaa</td> <td>0.100</td> <td></td> <td></td> </tr> <tr> <td>MOLD FLATNESS</td> <td>bbb</td> <td>0.100</td> <td></td> <td></td> </tr> <tr> <td>COPLANARITY</td> <td>ccc</td> <td>0.080</td> <td></td> <td></td> </tr> <tr> <td>DIMPLE WIDTH</td> <td>T</td> <td>0.300 REF</td> <td></td> <td></td> </tr> <tr> <td>DIMPLE LENGTH</td> <td>P</td> <td>0.150 REF</td> <td></td> <td></td> </tr> <tr> <td>DIMPLE DEPTH</td> <td>A2</td> <td>0.100 REF</td> <td></td> <td></td> </tr> </tbody> </table> <p>Notes: 1. Dimensioning and tolerancing conform to ASME Y14.5-2009 2. All dimensions are in millimeters</p> <table border="1" style="width: 100%; border-collapse: collapse; margin-top: 10px;"> <thead> <tr> <th colspan="2" style="text-align: center;">Package Outline</th> </tr> </thead> <tbody> <tr> <td style="text-align: center;">6L PQFV</td> <td style="text-align: center;">POD-PQFV-006-C05032-039</td> </tr> <tr> <td colspan="2" style="text-align: center;">5.000x3.200x0.850 mm</td> </tr> <tr> <td colspan="2" style="text-align: center;">2019/03/13 Rev 800 </td> </tr> </tbody> </table>		SYMBOL	MIN	NOM	MAX	TOTAL THICKNESS	A	0.800	0.850	0.900	STAND OFF	A1	0.000	0.035	0.050	BODY SIZE	X	D	5.000 BSC		Y	E	3.200 BSC		EP SIZE	X	J	3.100	3.200	3.300	Y	K	0.500	0.600	0.700	LEAD WIDTH	b	0.590	0.640	0.690	L	0.850	0.900	0.950	LEAD LENGTH	L1	1.000 REF			LEAD PITCH	e	1.270 BSC			PACKAGE TOLERANCE	aaa	0.100			MOLD FLATNESS	bbb	0.100			COPLANARITY	ccc	0.080			DIMPLE WIDTH	T	0.300 REF			DIMPLE LENGTH	P	0.150 REF			DIMPLE DEPTH	A2	0.100 REF			Package Outline		6L PQFV	POD-PQFV-006-C05032-039	5.000x3.200x0.850 mm		2019/03/13 Rev 800		<p>5.0 x 3.2 x 0.85 mm^[11]</p>
	SYMBOL	MIN	NOM	MAX																																																																																									
TOTAL THICKNESS	A	0.800	0.850	0.900																																																																																									
STAND OFF	A1	0.000	0.035	0.050																																																																																									
BODY SIZE	X	D	5.000 BSC																																																																																										
	Y	E	3.200 BSC																																																																																										
EP SIZE	X	J	3.100	3.200	3.300																																																																																								
	Y	K	0.500	0.600	0.700																																																																																								
LEAD WIDTH	b	0.590	0.640	0.690																																																																																									
	L	0.850	0.900	0.950																																																																																									
LEAD LENGTH	L1	1.000 REF																																																																																											
LEAD PITCH	e	1.270 BSC																																																																																											
PACKAGE TOLERANCE	aaa	0.100																																																																																											
MOLD FLATNESS	bbb	0.100																																																																																											
COPLANARITY	ccc	0.080																																																																																											
DIMPLE WIDTH	T	0.300 REF																																																																																											
DIMPLE LENGTH	P	0.150 REF																																																																																											
DIMPLE DEPTH	A2	0.100 REF																																																																																											
Package Outline																																																																																													
6L PQFV	POD-PQFV-006-C05032-039																																																																																												
5.000x3.200x0.850 mm																																																																																													
2019/03/13 Rev 800																																																																																													

Notes:

9. Top Marking: Y denotes manufacturing origin and XXXX denotes manufacturing lot number. The value of "Y" will depend on the assembly location of the device.
10. A capacitor of value 0.1 μF or higher between VDD and GND is required. An additional 10 μF capacitor between VDD and GND is required for the best phase jitter performance.
11. The center pad has no electrical function. Soldering down the center pad to the GND is recommended for best thermal dissipation, but is optional.

Dimensions and Patterns — 7.0 x 5.0 mm²

Package Size – Dimensions (Unit: mm) ^[12]	Recommended Land Pattern (Unit: mm) ^[13]																																																																																													
<p>7.0 x 5.0 x 0.85 mm^[14]</p> <table border="1" style="width: 100%; border-collapse: collapse; margin-top: 10px;"> <thead> <tr> <th></th> <th>SYMBOL</th> <th>MIN</th> <th>NOM</th> <th>MAX</th> </tr> </thead> <tbody> <tr> <td>TOTAL THICKNESS</td> <td>A</td> <td>0.800</td> <td>0.850</td> <td>0.900</td> </tr> <tr> <td>STAND OFF</td> <td>A1</td> <td>0.000</td> <td>0.035</td> <td>0.050</td> </tr> <tr> <td rowspan="2">BODY SIZE</td> <td>X</td> <td>D</td> <td colspan="2">7.000 BSC</td> </tr> <tr> <td>Y</td> <td>E</td> <td colspan="2">5.000 BSC</td> </tr> <tr> <td rowspan="2">EP SIZE</td> <td>X</td> <td>J</td> <td>3.400</td> <td>3.500</td> <td>3.600</td> </tr> <tr> <td>Y</td> <td>K</td> <td>1.400</td> <td>1.500</td> <td>1.600</td> </tr> <tr> <td>LEAD WIDTH</td> <td>b</td> <td>1.350</td> <td>1.400</td> <td>1.450</td> </tr> <tr> <td>LEAD LENGTH</td> <td>L</td> <td>0.850</td> <td>0.900</td> <td>0.950</td> </tr> <tr> <td>LEAD PITCH</td> <td>L1</td> <td colspan="3">1.000 REF</td> </tr> <tr> <td>LEAD PITCH</td> <td>e</td> <td colspan="3">2.540 BSC</td> </tr> <tr> <td>PACKAGE TOLERANCE</td> <td>aaa</td> <td colspan="3">0.100</td> </tr> <tr> <td>MOLD FLATNESS</td> <td>bbb</td> <td colspan="3">0.100</td> </tr> <tr> <td>COPLANRITY</td> <td>ccc</td> <td colspan="3">0.080</td> </tr> <tr> <td>DIMPLE WIDTH</td> <td>T</td> <td colspan="3">0.300 REF</td> </tr> <tr> <td>DIMPLE LENGTH</td> <td>P</td> <td colspan="3">0.150 REF</td> </tr> <tr> <td>DIMPLE DEPTH</td> <td>A2</td> <td colspan="3">0.100 REF</td> </tr> </tbody> </table> <p>Notes</p> <ol style="list-style-type: none"> Dimensioning and tolerancing conform to ASME Y14.5-2009 All dimensions are in millimeters <table border="1" style="width: 100%; border-collapse: collapse; margin-top: 10px;"> <thead> <tr> <th colspan="2" style="text-align: center;">Package Outline</th> </tr> </thead> <tbody> <tr> <td style="text-align: center;">6L PQFV</td> <td style="text-align: center;">POD-PQFV-006-C07050-037</td> </tr> <tr> <td colspan="2" style="text-align: center;">7.000x5.000x0.850 mm</td> </tr> <tr> <td colspan="2" style="text-align: center;">2019/03/13 Rev 800 </td> </tr> </tbody> </table>		SYMBOL	MIN	NOM	MAX	TOTAL THICKNESS	A	0.800	0.850	0.900	STAND OFF	A1	0.000	0.035	0.050	BODY SIZE	X	D	7.000 BSC		Y	E	5.000 BSC		EP SIZE	X	J	3.400	3.500	3.600	Y	K	1.400	1.500	1.600	LEAD WIDTH	b	1.350	1.400	1.450	LEAD LENGTH	L	0.850	0.900	0.950	LEAD PITCH	L1	1.000 REF			LEAD PITCH	e	2.540 BSC			PACKAGE TOLERANCE	aaa	0.100			MOLD FLATNESS	bbb	0.100			COPLANRITY	ccc	0.080			DIMPLE WIDTH	T	0.300 REF			DIMPLE LENGTH	P	0.150 REF			DIMPLE DEPTH	A2	0.100 REF			Package Outline		6L PQFV	POD-PQFV-006-C07050-037	7.000x5.000x0.850 mm		2019/03/13 Rev 800		<p>7.0 x 5.0 x 0.85 mm^[14]</p> <p>Note: Circles in center pad are thermal vias, recommended to improve thermal performance</p>
	SYMBOL	MIN	NOM	MAX																																																																																										
TOTAL THICKNESS	A	0.800	0.850	0.900																																																																																										
STAND OFF	A1	0.000	0.035	0.050																																																																																										
BODY SIZE	X	D	7.000 BSC																																																																																											
	Y	E	5.000 BSC																																																																																											
EP SIZE	X	J	3.400	3.500	3.600																																																																																									
	Y	K	1.400	1.500	1.600																																																																																									
LEAD WIDTH	b	1.350	1.400	1.450																																																																																										
LEAD LENGTH	L	0.850	0.900	0.950																																																																																										
LEAD PITCH	L1	1.000 REF																																																																																												
LEAD PITCH	e	2.540 BSC																																																																																												
PACKAGE TOLERANCE	aaa	0.100																																																																																												
MOLD FLATNESS	bbb	0.100																																																																																												
COPLANRITY	ccc	0.080																																																																																												
DIMPLE WIDTH	T	0.300 REF																																																																																												
DIMPLE LENGTH	P	0.150 REF																																																																																												
DIMPLE DEPTH	A2	0.100 REF																																																																																												
Package Outline																																																																																														
6L PQFV	POD-PQFV-006-C07050-037																																																																																													
7.000x5.000x0.850 mm																																																																																														
2019/03/13 Rev 800																																																																																														

Notes:

- Top Marking: Y denotes manufacturing origin and XXXX denotes manufacturing lot number. The value of "Y" will depend on the assembly location of the device.
- A capacitor of value 0.1 μ F or higher between VDD and GND is required. An additional 10 μ F capacitor between VDD and GND is required for the best phase jitter performance.
- The center pad has no electrical function. Soldering down the center pad to the GND is recommended for best thermal dissipation, but is optional.

Additional Information

Table 11. Additional Information

Document	Description	Download Link
ECCN #: EAR99	Five character designation used on the commerce Control List (CCL) to identify dual use items for export control purposes.	—
HTS Classification Code: 8542.39.0000	A Harmonized Tariff Schedule (HTS) code developed by the World Customs Organization to classify/define internationally traded goods.	—
Part number Generator	Tool used to create the part number based on desired features.	https://www.sitime.com/part-number-generator
Manufacturing Notes	Tape & Reel dimension, reflow profile and other manufacturing related info	https://www.sitime.com/sites/default/files/gated/Manufacturing-Notes-for-SiTime-Products.pdf
Qualification Reports	RoHS report, reliability reports, composition reports	http://www.sitime.com/support/quality-and-reliability
Performance Reports	Additional performance data such as phase noise, current consumption and jitter for selected frequencies	http://www.sitime.com/support/performance-measurement-report
Termination Techniques	Termination design recommendations	http://www.sitime.com/support/application-notes
Layout Techniques	Layout recommendations	http://www.sitime.com/support/application-notes
Evaluation Boards	SiT6085/6EB rev. 3.0, SiT6085EB rev.3.1 and SiT6097EB rev. 2.0 Evaluation Boards for Differential Oscillators User Manual	https://www.sitime.com/support/user-guides

Revision History

Table 12. Revision History

Revision	Release Date	Change Summary
1.0	6-Sep-2017	Final release
1.04	17-Apr-2018	Added 5032 package Added -40 to 95°C and -40 to 105°C temperature ranges Corrected minor errors Added Additional Information Table.
1.05	1-Oct-2018	Updated Ordering Information and performed minor edits Fixed formatting Updated 3225 package drawing to POD 38 RevA
1.06	25-Oct-2018	Removed "Contact SiTime" for ± 10 ppm
1.07	17-Aug-2019	Updated package Dimensions Drawings Updated Table 8 Thermal Considerations for 5032 package Updated Table 2 specification for First Year Aging Added 5, 10, and 20 year aging specs Added Evaluation Boards SiT6085EB reference in Additional Information Rearranged layout, added Description, Block Diagram and TOC Tightened LVDS minimum VOD specification Added HTS code Added low-swing LVPECL package code and specifications
1.08	9-Mar-2021	Updated L1 and Dimple Width package dimensions for 3.2 x 2.5 mm package Updated trademarks, hyperlinks and changed rev table date format
1.09	20-Jul-2021	Updated
1.1	1-Jan-2023	Updated company disclaimer, links, references and icons

SiTime Corporation, 5451 Patrick Henry Drive, Santa Clara, CA 95054, USA | **Phone:** +1-408-328-4400 | **Fax:** +1-408-328-4439

© SiTime Corporation 2015-2023. The information contained herein is subject to change at any time without notice. SiTime assumes no responsibility or liability for any loss, damage or defect of a Product which is caused in whole or in part by (i) use of any circuitry other than circuitry embodied in a SiTime product, (ii) misuse or abuse including static discharge, neglect or accident, (iii) unauthorized modification or repairs which have been soldered or altered during assembly and are not capable of being tested by SiTime under its normal test conditions, or (iv) improper installation, storage, handling, warehousing or transportation, or (v) being subjected to unusual physical, thermal, or electrical stress.

Disclaimer: SiTime makes no warranty of any kind, express or implied, with regard to this material, and specifically disclaims any and all express or implied warranties, either in fact or by operation of law, statutory or otherwise, including the implied warranties of merchantability and fitness for use or a particular purpose, and any implied warranty arising from course of dealing or usage of trade, as well as any common-law duties relating to accuracy or lack of negligence, with respect to this material, any SiTime product and any product documentation. This product is not suitable or intended to be used in a life support application or component, to operate nuclear facilities, in military or aerospace applications, or in other mission critical applications where human life may be involved or at stake. All sales are made conditioned upon compliance with the critical uses policy set forth below.

CRITICAL USE EXCLUSION POLICY

BUYER AGREES NOT TO USE SITIME'S PRODUCTS FOR ANY APPLICATION OR IN ANY COMPONENTS: USED IN LIFE SUPPORT DEVICES, TO OPERATE NUCLEAR FACILITIES, FOR MILITARY OR AEROSPACE USE, OR IN OTHER MISSION CRITICAL APPLICATIONS OR COMPONENTS WHERE HUMAN LIFE OR PROPERTY MAY BE AT STAKE.

For aerospace and defense applications, SiTime recommends using only [Endura™ ruggedized products](#).

SiTime owns all rights, title and interest to the intellectual property related to SiTime's products, including any software, firmware, copyright, patent, or trademark. The sale of SiTime products does not convey or imply any license under patent or other rights. SiTime retains the copyright and trademark rights in all documents, catalogs and plans supplied pursuant to or ancillary to the sale of products or services by SiTime. Unless otherwise agreed to in writing by SiTime, any reproduction, modification, translation, compilation, or representation of this material shall be strictly prohibited.

Looking for pricing, stock, or lifecycle information?

Click below to explore more details on WIN SOURCE:

 [View SIT9366AI-1B2-33E156.253906 on WIN SOURCE](#)

 [SiTIME Information](#)

Optimize Your Supply Chain with WIN SOURCE Solutions

-  Global Sourcing Solution
-  Obsolete Management
-  Cost Control Management
-  Shortage Management
-  Alternative Solution
-  Excess Inventory Management