



**THE DATASHEET OF
8422002AGI-07LFT**



General Description

The 8422002I-07 is a 2 output LVHSTL Synthesizer optimized to generate Fibre Channel reference clock frequencies and is a member of the family of high performance clock solutions from IDT. Using a 26.5625MHz 18pF parallel resonant crystal, the following frequencies can be generated based on the 2 frequency select pins (F_SEL[1:0]): 212.5MHz, 187.5MHz, 159.375MHz, 106.25MHz and 53.125MHz. The 8422002I-07 uses IDT's 3rd generation low phase noise VCO technology and can achieve 1ps or lower typical rms phase jitter, easily meeting Fibre Channel jitter requirements. The 8422002I-07 is packaged in a 20-pin TSSOP, EPad package.

Features

- Two LVHSTL outputs ($V_{OH,max} = 1.2V$)
- Selectable crystal oscillator interface or LVCMOS/LVTTL single-ended input
- Supports the following output frequencies: 212.5MHz, 187.5MHz, 159.375MHz, 106.25MHz, 53.125MHz
- VCO range: 560MHz - 680MHz
- RMS phase jitter @ 212.5MHz, using a 25MHz crystal (637kHz - 10MHz): 0.59ps (typical) design target
- Power supply modes:
Core/Output
3.3V/1.8V
2.5V/1.8V
- -40°C to 85°C ambient operating temperature
- Available in lead-free (RoHS 6) package

Frequency Select Function Table

Inputs				N Div. Value	M/N Div. Value	Output Frequency (MHz)
Input Frequency (MHz)	F_SEL1	F_SEL0	M Div. Value			
26.5625	0 (default)	0 (default)	24	3	8	212.5
26.5625	0	1	24	4	6	159.375
26.5625	1	0	24	6	4	106.25
26.5625	1	1	24	12	2	53.125
23.4375	0 (default)	0 (default)	24	3	8	187.5

Block Diagram

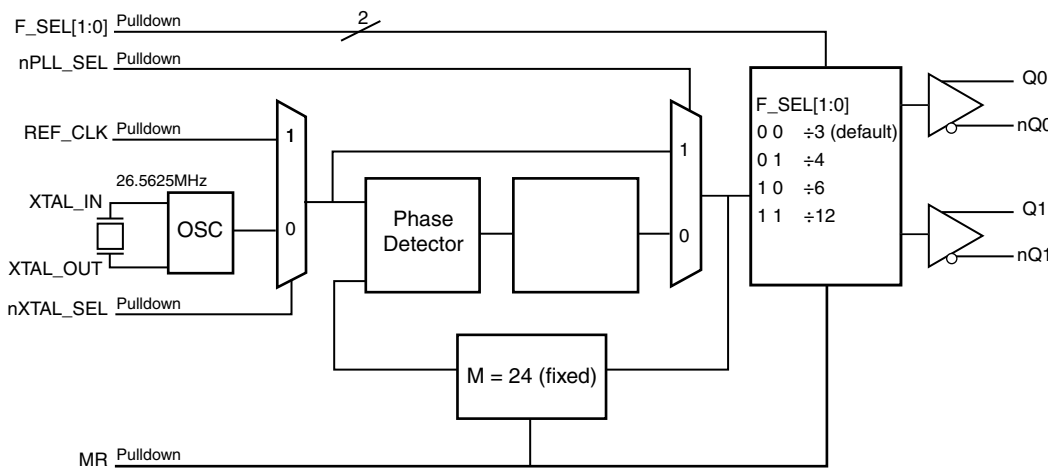

Pin Assignment

nc	1	20	VDD0
VDD0	2	19	Q1
Q0	3	18	nQ1
nQ0	4	17	GND
MR	5	16	VDD
nPLL_SEL	6	15	nXTAL_SEL
nc	7	14	REF_CLK
VDDA	8	13	XTAL_IN
F_SEL0	9	12	XTAL_OUT
VDD	10	11	F_SEL1

422002I-07
20-Lead TSSOP, EPad
4.4mm x 6.5mm x 0.90mm
package body
G Package
Top View

Table 1. Pin Descriptions

Number	Name	Type		Description
1, 7	nc	Unused		No connect.
2, 20	V _{DDO}	Power		Output supply pins.
3, 4	Q0, nQ0	Output		Differential output pair. LVHSTL interface levels.
5	MR	Input	Pulldown	Active HIGH Master Reset. When logic HIGH, the internal dividers are reset causing the true outputs Qx to go low and the inverted outputs nQx to go high. When logic LOW, the internal dividers and the outputs are enabled. LVCMOS/LVTTL interface levels.
6	nPLL_SEL	Input	Pulldown	PLL select control. When LOW, the selected reference clock is frequency-multiplied by the PLL. When HIGH, the PLL is bypassed and the selected reference clock is routed directly to the output dividers. LVCMOS/LVTTL interface levels.
8	V _{DDA}	Power		Analog supply pin.
9, 11	F_SEL0, F_SEL1	Input	Pulldown	Frequency select pins. LVCMOS/LVTTL interface levels.
10, 16	V _{DD}	Power		Core supply pins.
12, 13	XTAL_OUT, XTAL_IN	Input		Parallel resonant crystal interface. XTAL_OUT is the output, XTAL_IN is the input.
14	REF_CLK	Input	Pulldown	Single-ended reference clock input. LVCMOS/LVTTL interface levels.
15	nXTAL_SEL	Input	Pulldown	Selects between crystal or REF_CLK inputs as the PLL Reference source. Selects XTAL inputs when LOW. Selects REF_CLK when HIGH. LVCMOS/LVTTL interface levels.
17	GND	Power		Power supply ground.
18, 19	nQ1, Q1	Output		Differential output pair. LVHSTL interface levels.

NOTE: *Pulldown* refers to internal input resistors. See Table 2, *Pin Characteristics*, for typical values.

Table 2. Pin Characteristics

Symbol	Parameter	Test Conditions	Minimum	Typical	Maximum	Units
C _{IN}	Input Capacitance			4		pF
R _{PULLDOWN}	Input Pulldown Resistor			51		kΩ

Absolute Maximum Ratings

NOTE: Stresses beyond those listed under *Absolute Maximum Ratings* may cause permanent damage to the device. These ratings are stress specifications only. Functional operation of product at these conditions or any conditions beyond those listed in the *DC Characteristics* or *AC Characteristics* is not implied. Exposure to absolute maximum rating conditions for extended periods may affect product reliability.

Item	Rating
Supply Voltage, V_{DD}	4.6V
Inputs, V_I	-0.5V to $V_{DD} + 0.5V$
Outputs, I_O Continuous Current Surge Current	50mA 100mA
Package Thermal Impedance, θ_{JA}	33.1°C/W (0 mps)
Storage Temperature, T_{STG}	-65°C to 150°C

DC Electrical Characteristics

Table 3A. Power Supply DC Characteristics, $V_{DD} = 3.3V \pm 5\%$, $V_{DDO} = 1.8V \pm 0.2V$, $T_A = -40^\circ C$ to $85^\circ C$

Symbol	Parameter	Test Conditions	Minimum	Typical	Maximum	Units
V_{DD}	Core Supply Voltage		3.135	3.3	3.465	V
V_{DDA}	Analog Supply Voltage		$V_{DD} - 0.10$	3.3	V_{DD}	V
V_{DDO}	Output Supply Voltage		1.6	1.8	2.0	V
I_{DD}	Core Supply Current				112	mA
I_{DDA}	Analog Supply Current				10	mA
I_{DDO}	Output Supply Current	No Load			1	mA

Table 3B. Power Supply DC Characteristics, $V_{DD} = 2.5V \pm 5\%$, $V_{DDO} = 1.8V \pm 0.2V$, $T_A = -40^\circ C$ to $85^\circ C$

Symbol	Parameter	Test Conditions	Minimum	Typical	Maximum	Units
V_{DD}	Core Supply Voltage		2.375	2.5	2.625	V
V_{DDA}	Analog Supply Voltage		$V_{DD} - 0.10$	2.5	V_{DD}	V
V_{DDO}	Output Supply Voltage		1.6	1.8	2.0	V
I_{DD}	Core Supply Current				106	mA
I_{DDA}	Analog Supply Current				10	mA
I_{DDO}	Output Supply Current	No Load			1	mA

Table 3C. LVCMOS/LVTTL DC Characteristics, $T_A = -40^{\circ}\text{C}$ to 85°C

Symbol	Parameter	Test Conditions	Minimum	Typical	Maximum	Units
V_{IH}	Input High Voltage	$V_{DD} = 3.3\text{V}$	2		$V_{DD} + 0.3$	V
		$V_{DD} = 2.5\text{V}$	1.7		$V_{DD} + 0.3$	V
V_{IL}	Input Low Voltage	$V_{DD} = 3.3\text{V}$	-0.3		0.8	V
		$V_{DD} = 2.5\text{V}$	-0.3		0.7	V
I_{IH}	Input High Current	REF_CLK, MR, F_SEL[0:1], nPLL_SEL, nXTAL_SEL $V_{DD} = V_{IN} = 3.465\text{V}$ or 2.625V			150	μA
I_{IL}	Input Low Current	REF_CLK, MR, F_SEL[0:1], nPLL_SEL, nXTAL_SEL $V_{DD} = 3.465\text{V}$ or 2.625V , $V_{IN} = 0\text{V}$	-5			μA

Table 3D. LVHSTL DC Characteristics, $V_{DD} = 3.3\text{V} \pm 5\%$, $V_{DDO} = 1.8\text{V} \pm 0.2\text{V}$, $T_A = -40^{\circ}\text{C}$ to 85°C

Symbol	Parameter	Test Conditions	Minimum	Typical	Maximum	Units
V_{OH}	Output High Voltage; NOTE 1		0.9		1.2	V
V_{OL}	Output Low Voltage; NOTE 1		0		0.4	V
V_{OX}	Output Crossover Voltage; NOTE 2		0.45		0.80	V
V_{SWING}	Peak-to-Peak Output Voltage Swing		0.6		1.2	V

NOTE 1: Outputs termination with 50Ω to ground.

NOTE 2: Defined with respect to output voltage swing at a given condition.

Table 3E. LVHSTL DC Characteristics, $V_{DD} = 2.5\text{V} \pm 5\%$, $V_{DDO} = 1.8\text{V} \pm 0.2\text{V}$, $T_A = -40^{\circ}\text{C}$ to 85°C

Symbol	Parameter	Test Conditions	Minimum	Typical	Maximum	Units
V_{OH}	Output High Voltage; NOTE 1		0.9		1.2	V
V_{OL}	Output Low Voltage; NOTE 1		0		0.4	V
V_{OX}	Output Crossover Voltage; NOTE 2		0.50		0.90	V
V_{SWING}	Peak-to-Peak Output Voltage Swing		0.6		1.2	V

NOTE 1: Outputs termination with 50Ω to ground.

NOTE 2: Defined with respect to output voltage swing at a given condition.

Table 4. Crystal Characteristics

Parameter	Test Conditions	Minimum	Typical	Maximum	Units
Mode of Oscillation		Fundamental			
Frequency		23.33	26.5625	28.33	MHz
Equivalent Series Resistance (ESR)				50	Ω
Shunt Capacitance				7	pF

AC Electrical Characteristics

Table 5A. AC Characteristics, $V_{DD} = 3.3V \pm 5\%$, $V_{DDO} = 1.8V \pm 0.2V$, $T_A = -40^\circ\text{C}$ to 85°C

Parameter	Symbol	Test Conditions	Minimum	Typical	Maximum	Units
f_{OUT}	Output Frequency	$F_SEL[1:0] = 00$	186.67		226.66	MHz
		$F_SEL[1:0] = 01$	140		170	MHz
		$F_SEL[1:0] = 10$	93.33		113.33	MHz
		$F_SEL[1:0] = 11$	46.67		56.66	MHz
$t_{sk(o)}$	Output Skew; NOTE 1, 2			35	ps	
$f_{jit}(\emptyset)$	RMS Phase Jitter (Random); NOTE 3	212.5MHz, (637kHz – 10MHz)		0.59		ps
		187.5MHz, (637kHz – 10MHz)		0.53		ps
		159.375MHz, (637kHz – 10MHz)		0.56		ps
		106.25MHz, (1.875MHz – 20MHz)		0.56		ps
		53.125MHz, (637kHz – 10MHz)		0.66		ps
t_R / t_F	Output Rise/Fall Time	20% to 80%	275		875	ps
odc	Output Duty Cycle	$N \neq 3$	48		52	%
		$N = 3$	40		60	%

NOTE: Electrical parameters are guaranteed over the specified ambient operating temperature range, which is established when the device is mounted in a test socket with maintained transverse airflow greater than 500 lfpm. The device will meet specifications after thermal equilibrium has been reached under these conditions.

NOTE 1: Defined as skew between outputs at the same supply voltages and with equal load conditions. Measured at $V_{DDO}/2$.

NOTE 2: This parameter is defined in accordance with JEDEC Standard 65.

NOTE 3: Please refer to the Phase Noise Plot.

Table 5B. AC Characteristics, $V_{DD} = 2.5V \pm 5\%$, $V_{DDO} = 1.8V \pm 0.2V$, $T_A = -40^\circ\text{C}$ to 85°C

Parameter	Symbol	Test Conditions	Minimum	Typical	Maximum	Units
f_{OUT}	Output Frequency	$F_SEL[1:0] = 00$	186.67		226.66	MHz
		$F_SEL[1:0] = 01$	140		170	MHz
		$F_SEL[1:0] = 10$	93.33		113.33	MHz
		$F_SEL[1:0] = 11$	46.67		56.66	MHz
$t_{sk(o)}$	Output Skew; NOTE 1, 2			35	ps	
$f_{jit}(\emptyset)$	RMS Phase Jitter (Random); NOTE 3	212.5MHz, (637kHz – 10MHz)		0.60		ps
		187.5MHz, (637kHz – 10MHz)		0.72		ps
		159.375MHz, (637kHz – 10MHz)		0.64		ps
		106.25MHz, (1.875MHz – 20MHz)		0.55		ps
		53.125MHz, (637kHz – 10MHz)		0.68		ps
t_R / t_F	Output Rise/Fall Time	20% to 80%	250		650	ps
odc	Output Duty Cycle	$N \neq 3$	48		52	%
		$N = 3$	40		60	%

NOTE: Electrical parameters are guaranteed over the specified ambient operating temperature range, which is established when the device is mounted in a test socket with maintained transverse airflow greater than 500 lfpm. The device will meet specifications after thermal equilibrium has been reached under these conditions.

NOTE 1: Defined as skew between outputs at the same supply voltages and with equal load conditions. Measured at $V_{DDO}/2$.

NOTE 2: This parameter is defined in accordance with JEDEC Standard 65.

NOTE 3: Please refer to the Phase Noise Plot.

Typical Phase Noise at 212.5MHz ($V_{DD} = 3.3V, V_{DDO} = 1.8V$)

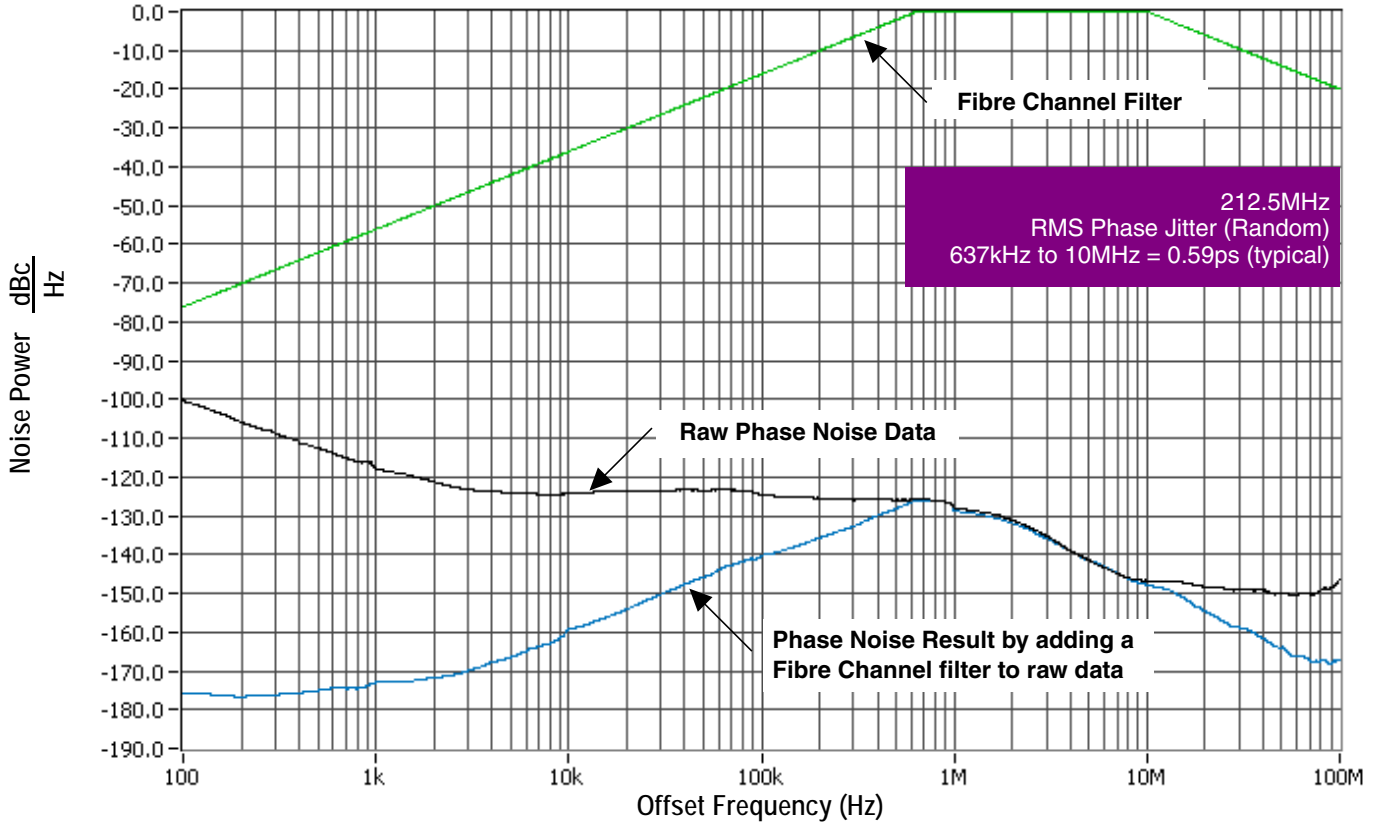

Typical Phase Noise at 106.25MHz ($V_{DD} = 3.3V, V_{DDO} = 1.8V$)

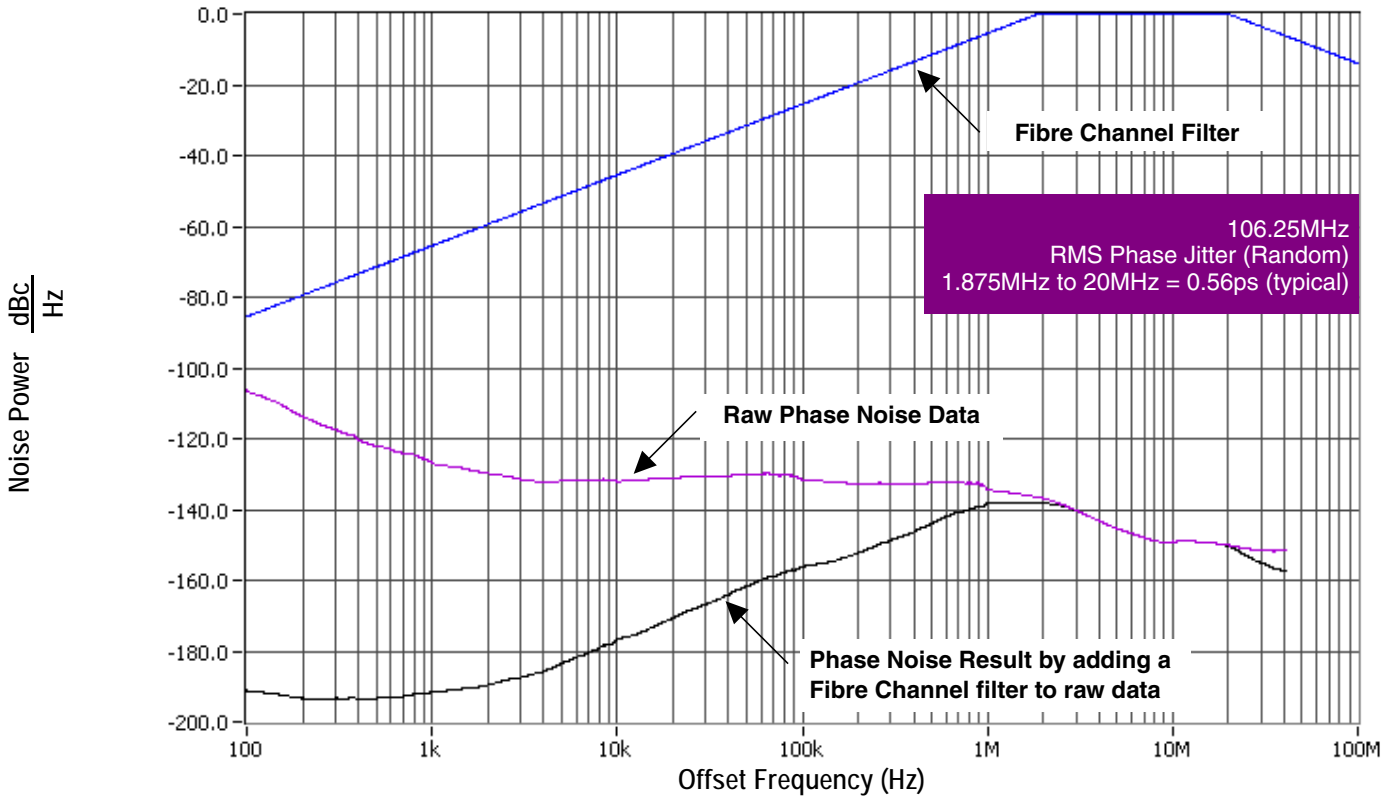

Parameter Measurement Information

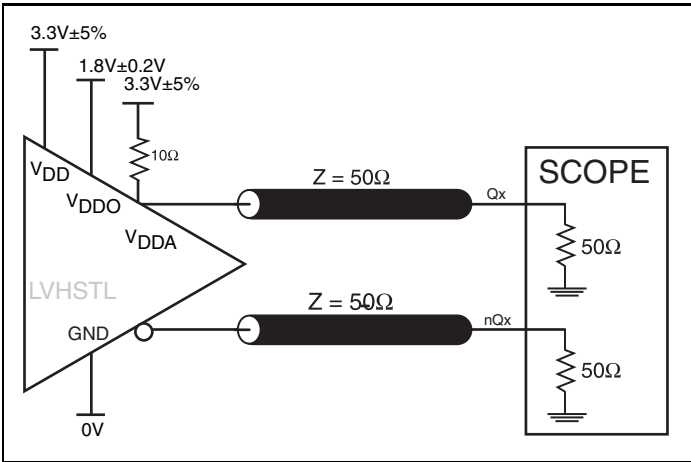

3.3V/1.8V Output Load AC Test Circuit

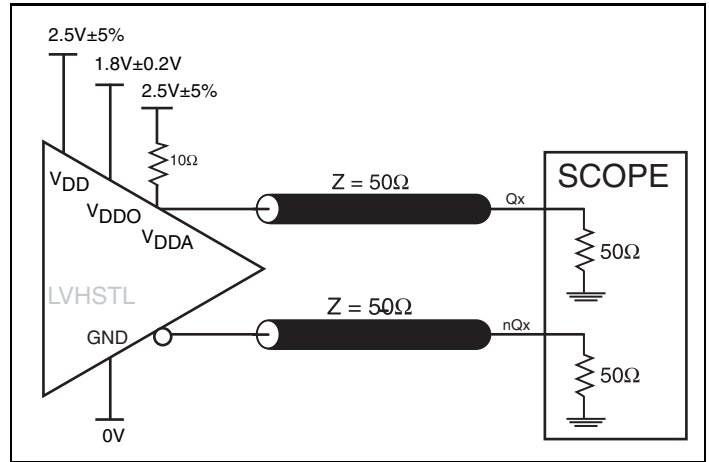

2.5V/1.8V Output Load AC Test Circuit

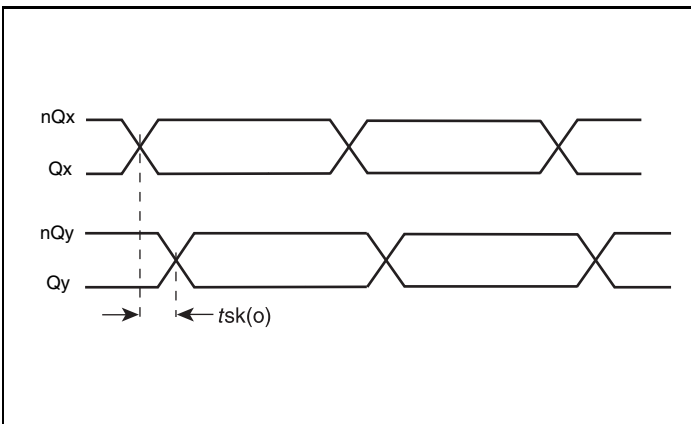

Output Skew

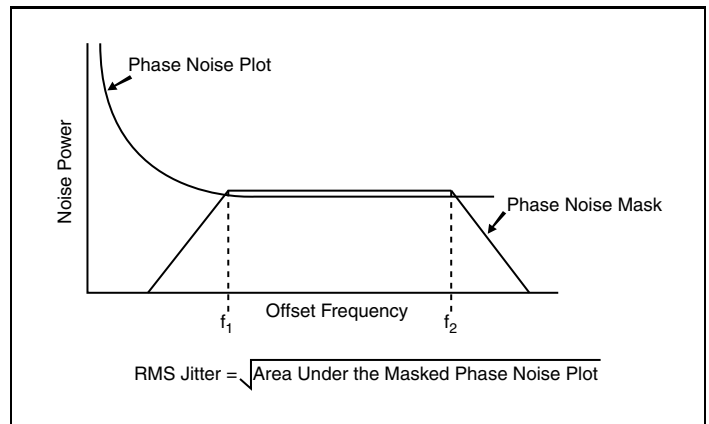

RMS Phase Jitter

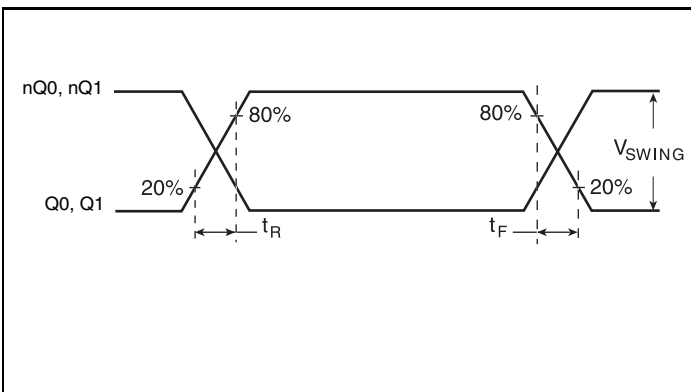

Output Rise/Fall Time

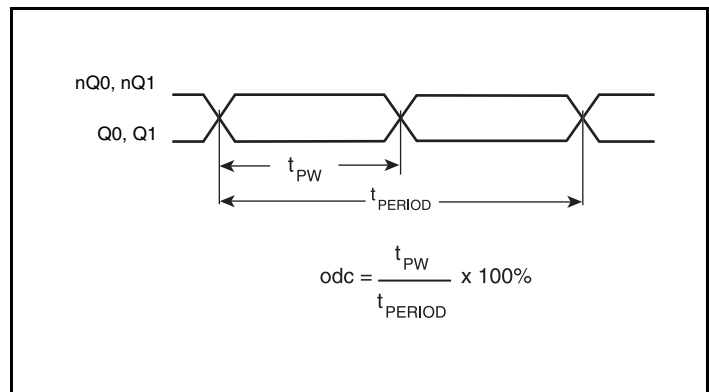

Output Duty Cycle/Pulse Width/Period

Application Information

Power Supply Filtering Technique

As in any high speed analog circuitry, the power supply pins are vulnerable to random noise. To achieve optimum jitter performance, power supply isolation is required. The 84220021-07 provides separate power supplies to isolate any high switching noise from the outputs to the internal PLL. V_{DD} , V_{DDA} and V_{DDO} should be individually connected to the power supply plane through vias, and $0.01\mu\text{F}$ bypass capacitors should be used for each pin. *Figure 1* illustrates this for a generic V_{DD} pin and also shows that V_{DDA} requires that an additional 10Ω resistor along with a $10\mu\text{F}$ bypass capacitor be connected to the V_{DDA} pin.

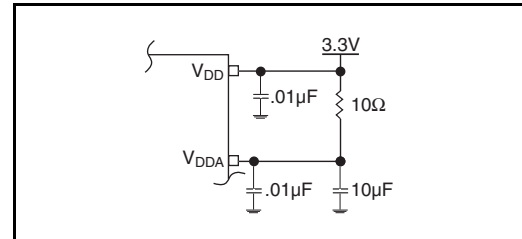

Figure 1. Power Supply Filtering

Recommendations for Unused Input and Output Pins

Inputs:

LVC MOS Control Pins

All control pins have internal pull-downs; additional resistance is not required but can be added for additional protection. A $1\text{k}\Omega$ resistor can be used.

Crystal Inputs

For applications not requiring the use of the crystal oscillator input, both XTAL_IN and XTAL_OUT can be left floating. Though not required, but for additional protection, a $1\text{k}\Omega$ resistor can be tied from XTAL_IN to ground.

REF_CLK Input

For applications not requiring the use of the reference clock, it can be left floating. Though not required, but for additional protection, a $1\text{k}\Omega$ resistor can be tied from the REF_CLK to ground.

Outputs:

LVHSTL Outputs

All unused LVHSTL outputs can be left floating. We recommend that there is no trace attached. Both sides of the differential output pair should either be left floating or terminated.

Crystal Input Interface

The 84220021-07 has been characterized with 18pF parallel resonant crystals. The capacitor values shown in *Figure 2* below

were determined using a 25MHz 18pF parallel resonant crystal and were chosen to minimize the ppm error.

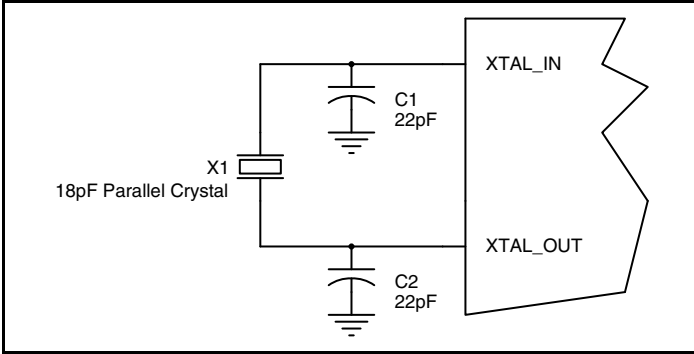

Figure 2. Crystal Input Interface

LVC MOS to XTAL Interface

The XTAL_IN input can accept a single-ended LVC MOS signal through an AC coupling capacitor. A general interface diagram is shown in *Figure 3*. The XTAL_OUT pin can be left floating. The input edge rate can be as slow as 10ns. For LVC MOS inputs, it is recommended that the amplitude be reduced from full swing to half swing in order to prevent signal interference with the power rail and to reduce noise. This configuration requires that the output

impedance of the driver (R_o) plus the series resistance (R_s) equals the transmission line impedance. In addition, matched termination at the crystal input will attenuate the signal in half. This can be done in one of two ways. First, R_1 and R_2 in parallel should equal the transmission line impedance. For most 50Ω applications, R_1 and R_2 can be 100Ω. This can also be accomplished by removing R_1 and making R_2 50Ω.

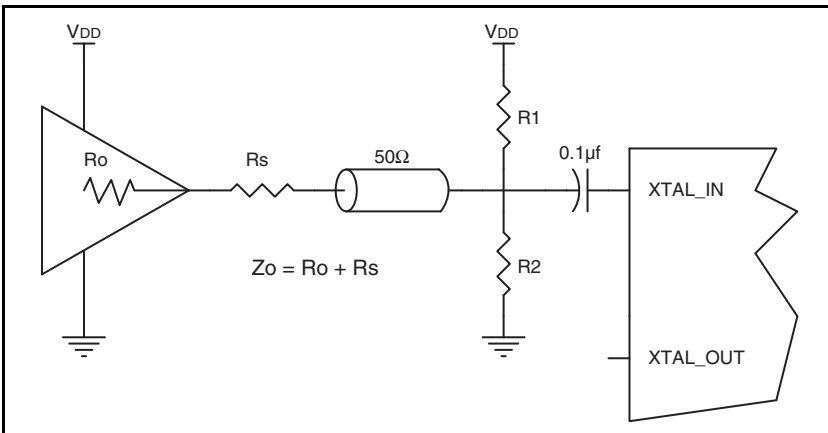

Figure 3. General Diagram for LVC MOS Driver to XTAL Input Interface

EPAD Thermal Release Path

In order to maximize both the removal of heat from the package and the electrical performance, a land pattern must be incorporated on the Printed Circuit Board (PCB) within the footprint of the package corresponding to the exposed metal pad or exposed heat slug on the package, as shown in *Figure 4*. The solderable area on the PCB, as defined by the solder mask, should be at least the same size/shape as the exposed pad/slug area on the package to maximize the thermal/electrical performance. Sufficient clearance should be designed on the PCB between the outer edges of the land pattern and the inner edges of pad pattern for the leads to avoid any shorts.

While the land pattern on the PCB provides a means of heat transfer and electrical grounding from the package to the board through a solder joint, thermal vias are necessary to effectively conduct from the surface of the PCB to the ground plane(s). The land pattern must be connected to ground through these vias. The vias act as “heat pipes”. The number of vias (i.e. “heat pipes”) are

application specific and dependent upon the package power dissipation as well as electrical conductivity requirements. Thus, thermal and electrical analysis and/or testing are recommended to determine the minimum number needed. Maximum thermal and electrical performance is achieved when an array of vias is incorporated in the land pattern. It is recommended to use as many vias connected to ground as possible. It is also recommended that the via diameter should be 12 to 13mils (0.30 to 0.33mm) with 1oz copper via barrel plating. This is desirable to avoid any solder wicking inside the via during the soldering process which may result in voids in solder between the exposed pad/slug and the thermal land. Precautions should be taken to eliminate any solder voids between the exposed heat slug and the land pattern. Note: These recommendations are to be used as a guideline only. For further information, refer to the Application Note on the *Surface Mount Assembly* of Amkor’s Thermally/Electrically Enhance Leadframe Base Package, Amkor Technology.

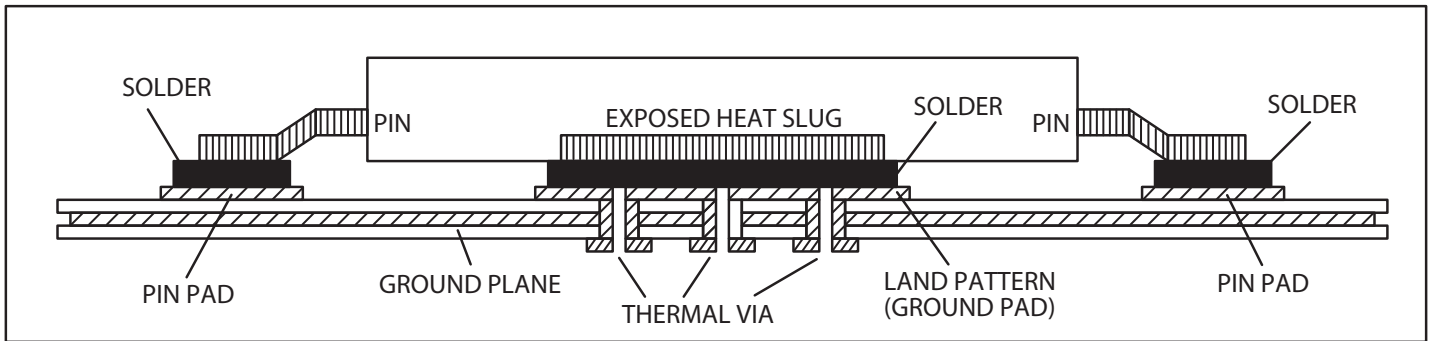

Figure 4. Assembly for Exposed Pad Thermal Release Path - Side View (drawing not to scale)

Schematic Example

Figure 5 shows an example of the 8422002I-07 application schematic. In this example, the device is operated at $V_{DD} = 3.3V$ and $V_{DDO} = 1.8V$. Both input options are shown. The device can either be driven using a quartz crystal or a 3.3V LVCMOS signal. The $C1 = 22pF$ and $C2 = 22pF$ are recommended for frequency

accuracy. For different board layouts, the $C1$ and $C2$ may be slightly adjusted for optimizing frequency accuracy. The LVHSTL output driver termination examples are shown in this schematic. The decoupling capacitors should be located as close as possible to the power pin.

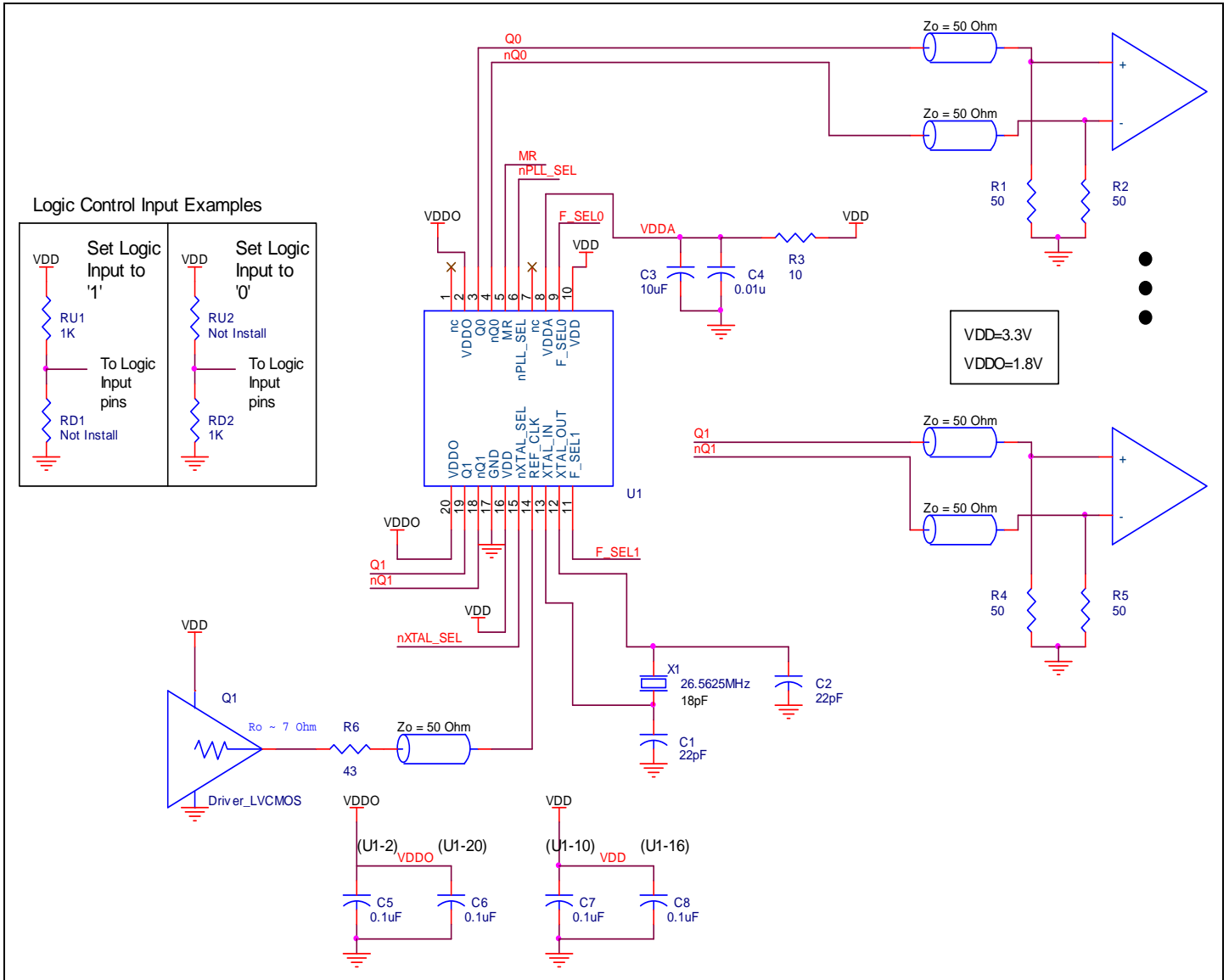

Figure 5. 8422002I-07 LVHSTL Schematic Example

Power Considerations

This section provides information on power dissipation and junction temperature for the 8422002I-07. Equations and example calculations are also provided.

1. Power Dissipation.

The total power dissipation for the 8422002I-07 is the sum of the core power plus the analog power plus the power dissipated in the load(s). The following is the power dissipation for $V_{DD} = 3.3V + 5\% = 3.465V$, which gives worst case results.

NOTE: Please refer to Section 3 for details on calculating power dissipated in the load.

- Power (core)_{MAX} = $V_{DD_MAX} * (I_{DD_MAX} + I_{DDA_MAX}) = 3.465V * (112mA + 10mA) = \mathbf{422.73mW}$
- Power (outputs)_{MAX} = **32mW/Loaded Output pair**
If all outputs are loaded, the total power is $2 * 32mW = \mathbf{64mW}$

Total Power_{MAX} (3.465V, with all outputs switching) = $422.73mW + 64mW = \mathbf{486.73mW}$

2. Junction Temperature.

Junction temperature, T_j , is the temperature at the junction of the bond wire and bond pad and directly affects the reliability of the device. The maximum recommended junction temperature for HiPerClockS devices is 125°C.

The equation for T_j is as follows: $T_j = \theta_{JA} * Pd_total + T_A$

T_j = Junction Temperature

θ_{JA} = Junction-to-Ambient Thermal Resistance

Pd_total = Total Device Power Dissipation (example calculation is in section 1 above)

T_A = Ambient Temperature

In order to calculate junction temperature, the appropriate junction-to-ambient thermal resistance θ_{JA} must be used. Assuming no air flow and a multi-layer board, the appropriate value is 33.1°C/W per Table 6 below.

Therefore, T_j for an ambient temperature of 85°C with all outputs switching is:

$$85^\circ\text{C} + 0.487\text{W} * 33.1^\circ\text{C/W} = 101.1^\circ\text{C}. \text{ This is well below the limit of } 125^\circ\text{C}.$$

This calculation is only an example. T_j will obviously vary depending on the number of loaded outputs, supply voltage, air flow and the type of board (multi-layer).

Table 6. Thermal Resistance θ_{JA} for 20 Lead TSSOP, EPad Forced Convection

Meters per Second	θ_{JA} by Velocity		
	0	1	2.5
Multi-Layer PCB, JEDEC Standard Test Boards	33.1°C/W	26.6°C/W	25.1°C/W

3. Calculations and Equations.

The purpose of this section is to derive the power dissipated into the load.

LVHSTL output driver circuit and termination are shown in *Figure 6*.

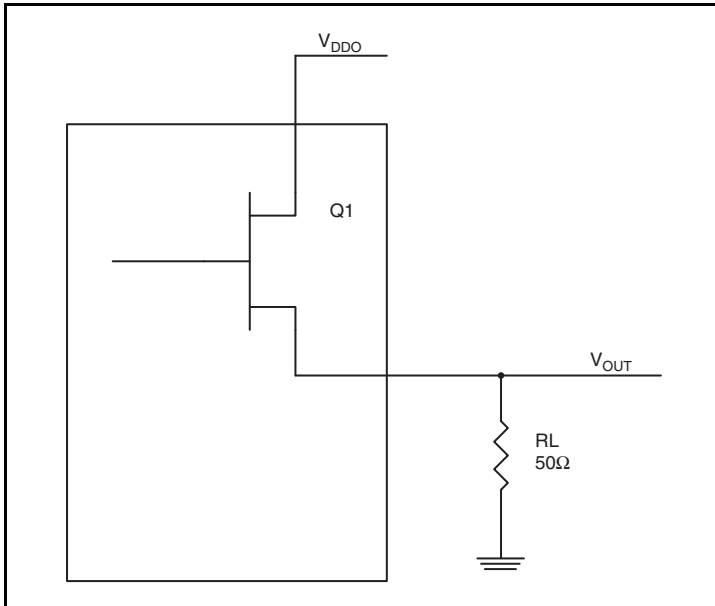

Figure 6. LVHSTL Driver Circuit and Termination

To calculate worst case power dissipation into the load, use the following equations which assume a 50Ω load.

Pd_H is power dissipation when the output drives high.

Pd_L is the power dissipation when the output drives low.

$$Pd_H = (V_{OH_MAX} / R_L) * (V_{DDO_MAX} - V_{OH_MAX})$$

$$Pd_L = (V_{OL_MAX} / R_L) * (V_{DDO_MAX} - V_{OL_MAX})$$

$$Pd_H = (1.2V / 50\Omega) * (2V - 1.2V) = \mathbf{19.2mW}$$

$$Pd_L = (0.4V / 50\Omega) * (2V - 0.4V) = \mathbf{12.8mW}$$

$$\text{Total Power Dissipation per output pair} = Pd_H + Pd_L = \mathbf{32mW}$$

Reliability Information

Table 7. θ_{JA} vs. Air Flow Table for a 20 Lead TSSOP, EPad

θ_{JA} by Velocity			
Meters per Second	0	1	2.5
Multi-Layer PCB, JEDEC Standard Test Boards	33.1°C/W	26.6°C/W	25.1°C/W

Transistor Count

The transistor count for 8422002I-07 is: 2951

Package Outline and Package Dimensions

Package Outline - G Suffix for 20 Lead TSSOP, EPad

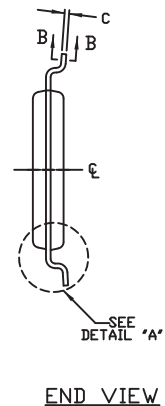
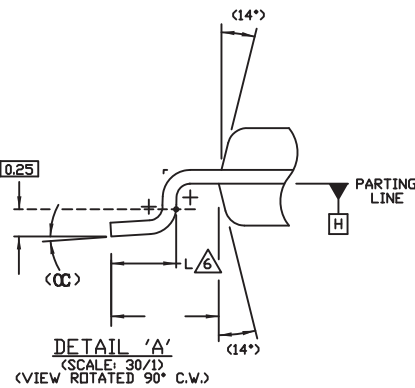
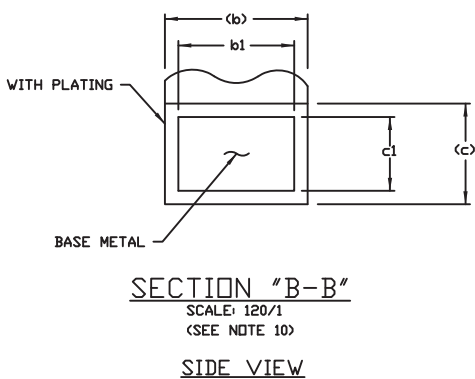
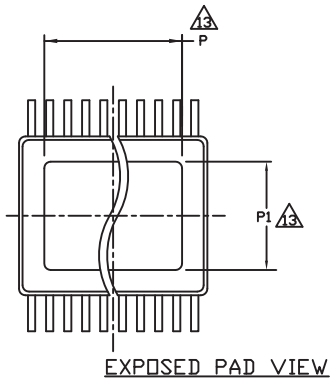
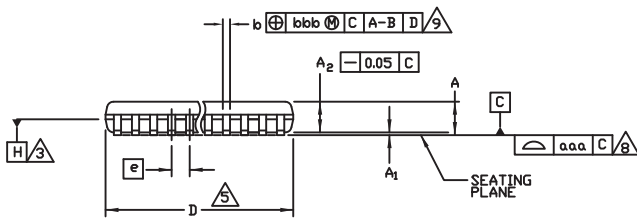
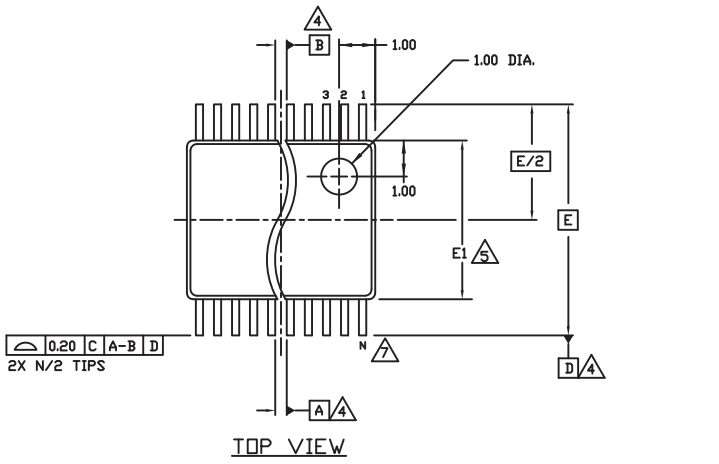
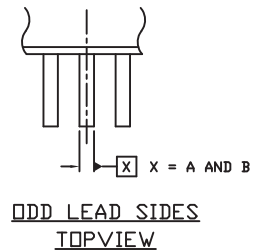
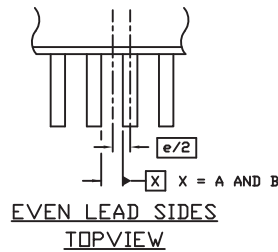

Table 8. Package Dimensions for 20 Lead TSSOP, EPad

All Dimensions in Millimeters		
Symbol	Minimum	Maximum
N	20	
A		1.10
A1	0.05	0.15
A2	0.85	0.95
b	0.19	0.30
b1	0.19	0.25
c	0.09	0.20
c1	0.09	0.16
D	6.40	6.60
E	6.40 Basic	
E1	4.30	4.50
e	0.65 Basic	
L	0.50	0.70
P		4.2
P1		3.0
α	0°	8°
aaa		0.076
bbb	0.10	

Reference Document: JEDEC Publication 95, MO-153



Ordering Information

Table 9. Ordering Information

Part/Order Number	Marking	Package	Shipping Packaging	Temperature
8422002AGI-07LF	ICS2002AI07L	“Lead-Free” 20 Lead TSSOP, E-Pad	Tube	-40°C to 85°C
8422002AGI-07LFT	ICS2002AI07L	“Lead-Free” 20 Lead TSSO, E-Pad	Tape & Reel	-40°C to 85°C

Revision History

Revision Date	Description of Change
January 28,2016	<ul style="list-style-type: none">▪ Removed ICS from the part numbers where needed.▪ General Description - removed the ICS chip and HiPerClockS.▪ Features section - remove reference to leaded package.▪ Ordering Information - removed quantity from tape and reel. Deleted LF note below table.▪ Updated header and footer.

IMPORTANT NOTICE AND DISCLAIMER

RENESAS ELECTRONICS CORPORATION AND ITS SUBSIDIARIES (“RENESAS”) PROVIDES TECHNICAL SPECIFICATIONS AND RELIABILITY DATA (INCLUDING DATASHEETS), DESIGN RESOURCES (INCLUDING REFERENCE DESIGNS), APPLICATION OR OTHER DESIGN ADVICE, WEB TOOLS, SAFETY INFORMATION, AND OTHER RESOURCES “AS IS” AND WITH ALL FAULTS, AND DISCLAIMS ALL WARRANTIES, EXPRESS OR IMPLIED, INCLUDING, WITHOUT LIMITATION, ANY IMPLIED WARRANTIES OF MERCHANTABILITY, FITNESS FOR A PARTICULAR PURPOSE, OR NON-INFRINGEMENT OF THIRD-PARTY INTELLECTUAL PROPERTY RIGHTS.

These resources are intended for developers who are designing with Renesas products. You are solely responsible for (1) selecting the appropriate products for your application, (2) designing, validating, and testing your application, and (3) ensuring your application meets applicable standards, and any other safety, security, or other requirements. These resources are subject to change without notice. Renesas grants you permission to use these resources only to develop an application that uses Renesas products. Other reproduction or use of these resources is strictly prohibited. No license is granted to any other Renesas intellectual property or to any third-party intellectual property. Renesas disclaims responsibility for, and you will fully indemnify Renesas and its representatives against, any claims, damages, costs, losses, or liabilities arising from your use of these resources. Renesas' products are provided only subject to Renesas' Terms and Conditions of Sale or other applicable terms agreed to in writing. No use of any Renesas resources expands or otherwise alters any applicable warranties or warranty disclaimers for these products.

(Disclaimer Rev.1.01 Jan 2024)

Corporate Headquarters

TOYOSU FORESIA, 3-2-24 Toyosu,
Koto-ku, Tokyo 135-0061, Japan
www.renesas.com

Trademarks



Renesas and the Renesas logo are trademarks of Renesas Electronics Corporation. All trademarks and registered trademarks are the property of their respective owners.

Contact Information

For further information on a product, technology, the most up-to-date version of a document, or your nearest sales office, please visit www.renesas.com/contact-us/.

Looking for pricing, stock, or lifecycle information?

Click below to explore more details on WIN SOURCE:

-  [View 8422002AGI-07LFT on WIN SOURCE](#)
-  [Renesas Electronics America](#) Information

Optimize Your Supply Chain with WIN SOURCE Solutions

-  Global Sourcing Solution
-  Obsolete Management
-  Cost Control Management
-  Shortage Management
-  Alternative Solution
-  Excess Inventory Management