



THE DATASHEET OF AHS120-2



Specification Status: Released

Maximum Electrical Rating
Operating Voltage / Interrupt Current
16V_{DC} / 50A

Marking:

- H12** – Part Identification
- Manufacturer's Mark
- Lot Identification

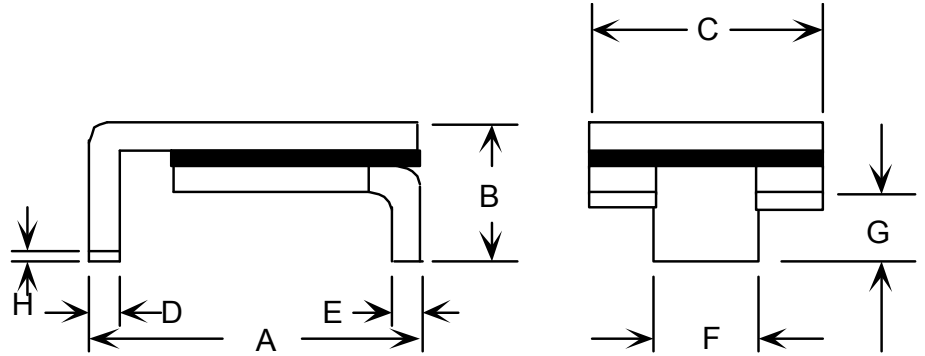

Notes:

1. All metal surfaces are tin plated.
2. Drawing not to scale.

TABLE I. DIMENSIONS:

	A		B		C		D		E		F		G		H
	MIN	MAX	MIN	MAX	MIN	MAX	MIN	MAX	MIN	MAX	MIN	MAX	MIN	MAX	MIN
mm:	6.73	7.98	--	3.00	4.8	5.44	0.56	0.71	0.56	0.71	2.16	2.41	0.66	1.37	0.43
in*:	(0.265)	(0.314)	--	(0.118)	(0.19)	(0.214)	(0.022)	(0.028)	(0.022)	(0.028)	(0.085)	(0.095)	(0.026)	(0.054)	(0.017)

TABLE II. PERFORMANCE RATINGS:

CURRENT RATINGS**						TIME TO TRIP**	RESISTANCE VALUES		TRIPPED-STATE POWER DISSIPATION**
AMPS AT 0°C		AMPS AT 20°C		AMPS AT 60°C		SECONDS AT 20°C, 8.0A MAX	OHMS AT 20°C		WATTS AT 20°C
HOLD	TRIP	HOLD	TRIP	HOLD	TRIP		MIN	MAX*	MAX
1.36	3.29	1.20	2.30	0.83	1.60	2.0	0.150	0.340	2.2

* Maximum resistance is measured 1 hour after reflow.

** Values specified were determined using PCB's with 0.100"X2.0 ounce copper traces.

Reference Documents:

PS300, PS400

Precedence:

This specification takes precedence over documents referenced herein.

Effectivity:

Reference documents shall be the issue in effect on the date of invitation for bid.

CAUTION:

Operation beyond the rated voltage or current may result in rupture, electrical arcing or flame.

Materials Information

ROHS Compliant

Directive 2002/95/EC
Compliant

ELV Compliant

Directive 2000/53/EC
Compliant

Pb-Free



Halogen Free*





* Halogen Free refers to: Br≤900ppm, Cl≤900ppm, Br+Cl≤1500ppm.

Information furnished is believed to be accurate and reliable. However, users should independently evaluate the suitability of and test each product selected for their own applications. Littelfuse products are not designed for, and shall not be used for, any purpose (including, without limitation, military, aerospace, medical, lifesaving, life-sustaining or nuclear facility applications, devices intended for surgical implant into the body, or any other application in which the failure or lack of desired operation of the product may result in personal injury, death, or property damage) other than those expressly set forth in applicable Littelfuse product documentation. Warranties granted by Littelfuse shall be deemed void for products used for any purpose not expressly set forth in applicable Littelfuse documentation. Littelfuse shall not be liable for any claims or damages arising out of products used in applications not expressly intended by Littelfuse as set forth in applicable Littelfuse documentation. The sale and use of Littelfuse products is subject to Littelfuse Terms and Conditions of Sale, unless otherwise agreed by Littelfuse.

Looking for pricing, stock, or lifecycle information?

Click below to explore more details on WIN SOURCE:

-  [View AHS120-2 on WIN SOURCE](#)
-  [Littelfuse Inc. Information](#)

Optimize Your Supply Chain with WIN SOURCE Solutions

-  Global Sourcing Solution
-  Obsolete Management
-  Cost Control Management
-  Shortage Management
-  Alternative Solution
-  Excess Inventory Management