



**THE DATASHEET OF  
Z86C3012PSCR4457**





# Z86C30/C31/C32/C40

## CMOS Z8® CONSUMER CONTROLLER PROCESSOR

### FEATURES

Part	ROM (KB)	RAM* (Byte)	Speed (MHz)
Z86C30	4	237	16
Z86C31	2	125	12
Z86C32	2	237	12
Z86C40	4	236	16

\* General-Purpose

- 28-Pin DIP, 28-Pin SOIC, 28-Pin PLCC Packages (Z86C3X)  
40-Pin DIP, 44-Pin PLCC/QFP Packages (Z86C40)
- 3.0V to 5.5V Operating Range
- Low-Power Consumption
- -40°C to +105°C Operating Range
- Expanded Register File (ERF)
- 32 Input/Output Lines (C40)  
24 Input/Output Lines (C3X)
- Vectored, Prioritized Interrupts with Programmable Polarity
- Two Analog Comparators
- Two Programmable 8-Bit Counter/Timers, Each with Two 6-Bit Programmable Prescaler
- Watch-Dog Timer/Power-On Reset
- On-Chip Oscillator that Accepts a Crystal, Ceramic Resonator, LC, RC, or External Clock
- RAM and ROM Protect

### GENERAL DESCRIPTION

The Z86C3X/C40 Consumer Controller Processors (CCP) are members of the Z8® single-chip microcontroller family offering a unique register-to-register architecture that avoids accumulator bottlenecks and offers fast execution of code.

Three address spaces (Program Memory, Register File, and Expanded Register File [ERF]), support a wide range of memory configurations. Through the ERF, the designer has access to three additional control registers that provide extra peripheral devices, I/O ports, and register addresses. The rest of the ERF is not physically implemented and is open for future expansion.

For applications demanding powerful I/O capabilities, the Z86C3X/C40's dedicated input and output lines are grouped into three and four ports, respectively, and are configurable under software control to provide timing, status signals, or parallel I/O.

Two on-chip counter/timers, with a large number of selectable modes, offload the system of administering real-time tasks such as counting/timing and I/O data communications.

With ROM/ROMless selectivity, the Z86C40 provides both external memory and pre-programmed ROM, which enables these Z8 microcontrollers to be used in high-volume applications, or where code flexibility is required.

#### Notes:

All Signals with a preceding front slash, "/", are active Low, e.g.: B/W (WORD is active Low); /B/W (BYTE is active Low, only).

Power connections follow conventional descriptions below:

Connection	Circuit	Device
Power	V <sub>CC</sub>	V <sub>DD</sub>
Ground	GND	V <sub>SS</sub>

## GENERAL DESCRIPTION (Continued)

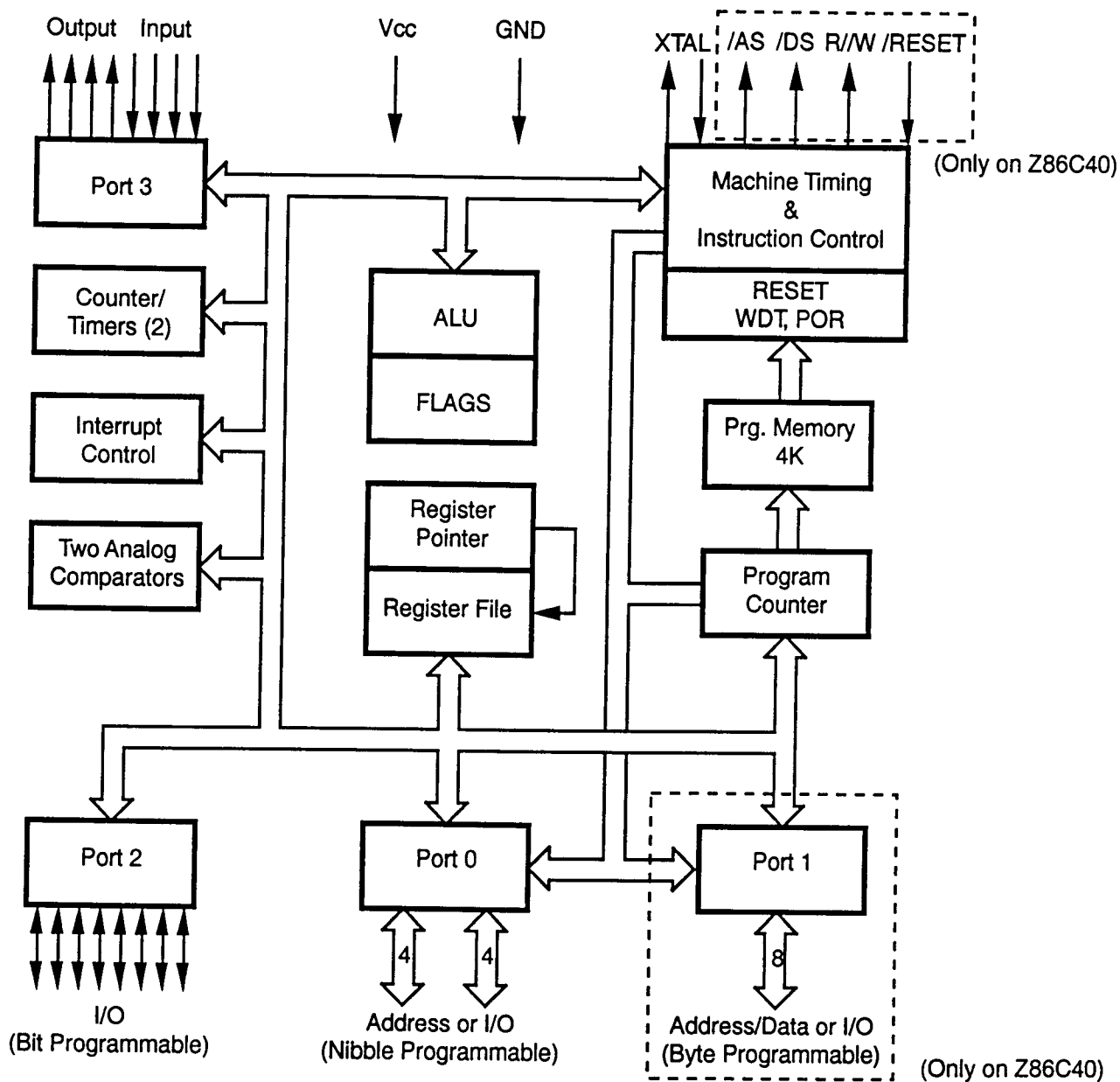

Functional Block Diagram

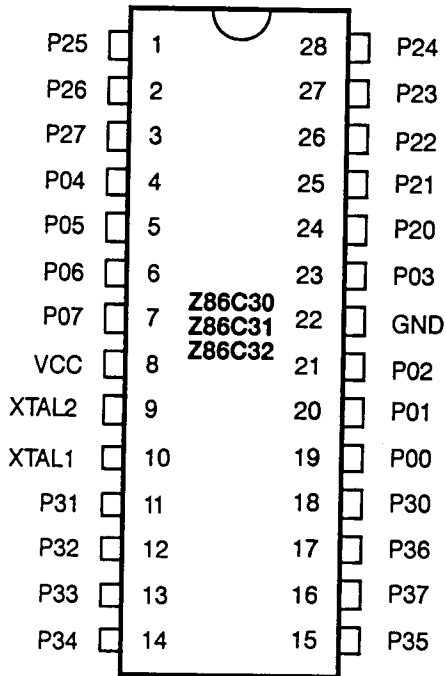
**PIN DESCRIPTION**

**28-Pin DIP Configuration**
**28-Pin DIP/SOIC/PLCC Pin Identification**

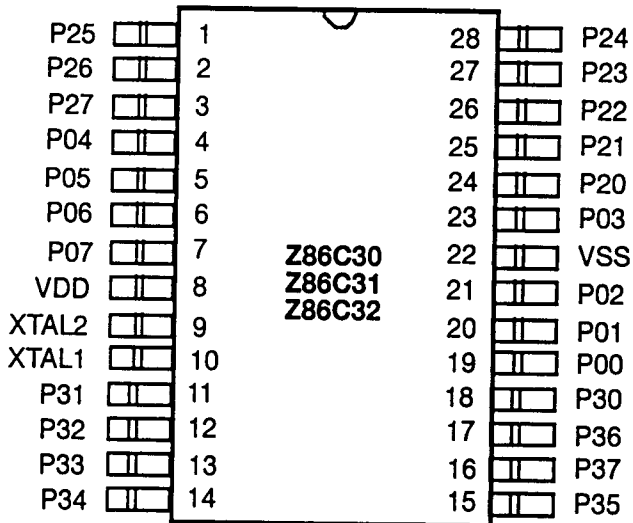
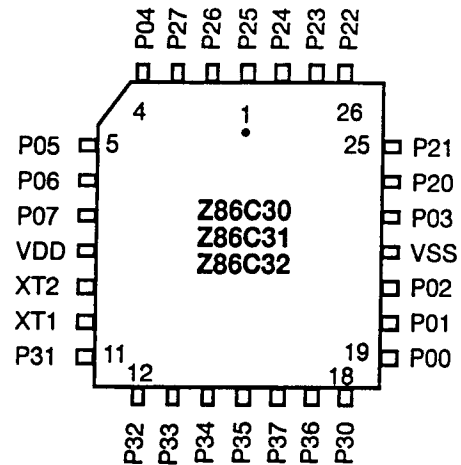
Pin #	Symbol	Function	Direction
1-3	P27-25	Port 2, Pins 5,6,7	In/Output
4-7	P07-04	Port 0, Pins 4,5,6,7	In/Output
8	V <sub>cc</sub>	Power Supply	
9	XTAL2	Crystal Oscillator	Output
10	XTAL1	Crystal Oscillator	Input
11-13	P33-31	Port 3, Pins 1,2,3	Fixed Input
14-15	P35-4	Port 3, Pins 4,5	Fixed Output
16	P37	Port 3, Pin 7	Fixed Output
17	P36	Port 3, Pin 6	Fixed Output
18	P30	Port 3, Pin 0	Fixed Input
19-21	P02-00	Port 0, Pins 0,1,2	In/Output
22	GND	Ground, V <sub>ss</sub>	
23	P03	Port 0, Pin 3	In/Output
24-28	P24-20	Port 2, Pins 0,1,2,3,4	In/Output

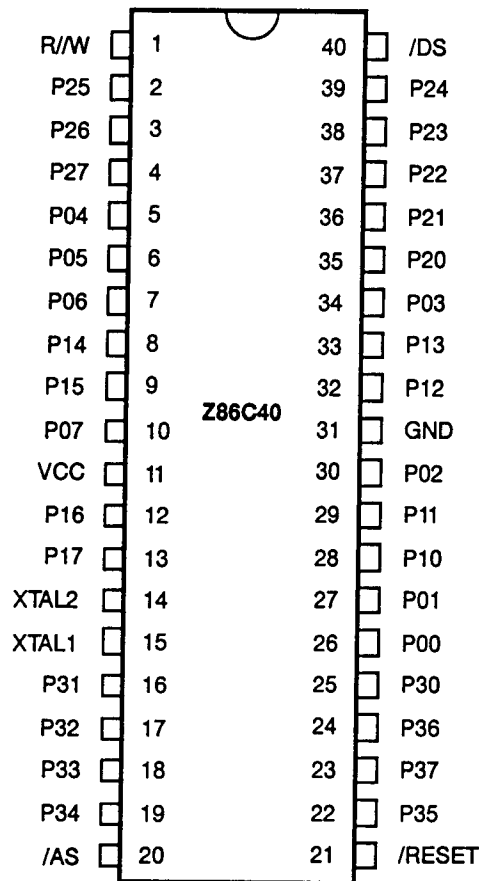

**28-Pin SOIC Configuration**

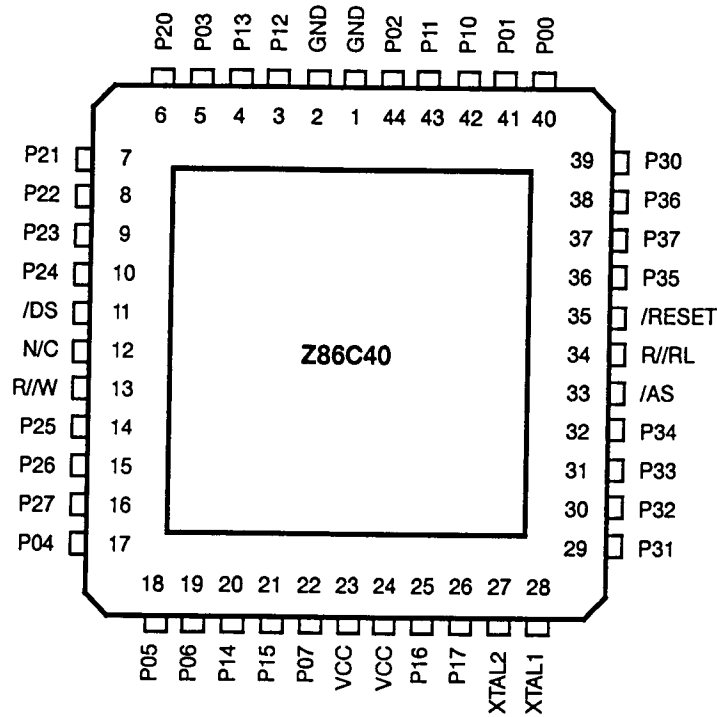
**28-Pin PLCC Configuration**

**PIN DESCRIPTION (Continued)**

**40-Pin DIP Assignments**
**40-Pin Dual-In-Line Package Pin Identification**

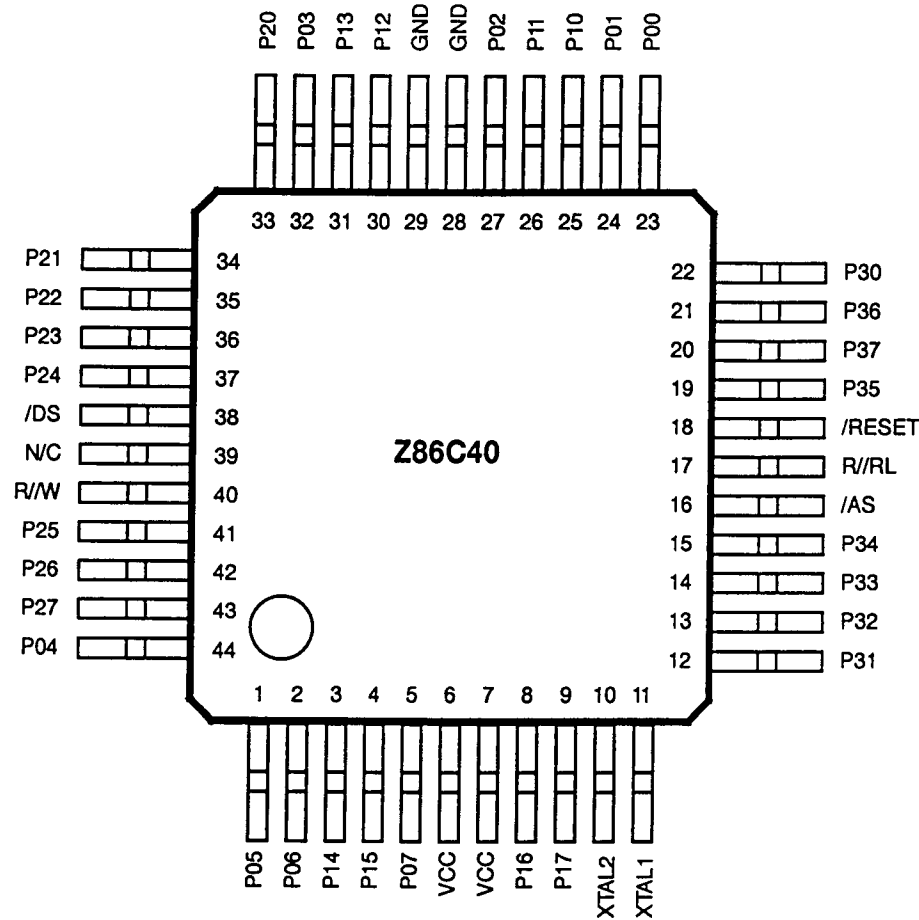
Pin #	Symbol	Function	Direction	Pin #	Symbol	Function	Direction
1	R/W	Read/Write	Output	22	P35	Port 3, Pin 5	Output
2-4	P25-27	Port 2, Pins 5,6,7	In/Output	23	P37	Port 3, Pin 7	Output
5-7	P04-06	Port 0, Pins 4,5,6	In/Output	24	P36	Port 3, Pin 6	Output
8-9	P14-15	Port 1, Pins 4,5	In/Output	25	P30	Port 3, Pin 0	Input
10	P07	Port 0, Pin 7	In/Output	26-27	P00-01	Port 0, Pin 0,1	In/Output
11	V <sub>CC</sub>	Power Supply		28-29	P10-11	Port 1, Pin 0,1	In/Output
12-13	P16-17	Port 1, Pins 6,7	In/Output	30	P02	Port 0, Pin 2	In/Output
14	XTAL2	Crystal, Oscillator Clock	Output	31	GND	Ground, GND	
15	XTAL1	Crystal, Oscillator Clock	Input	32-33	P12-13	Port 1, Pin 2,3	In/Output
16-18	P31-33	Port 3, Pins 1,2,3	Input	34	P03	Port 0, Pin 3	In/Output
19	P34	Port 3, Pin 4	Output	35-39	P20-24	Port 2, Pin 0,1,2,3,4	In/Output
20	/AS	Address Strobe	Output	40	/DS	Data Strobe	Output
21	/RESET	Reset	Input				

**PIN DESCRIPTION (Continued)**

**44-Pin PLCC Pin Assignments**
**44-Pin PLCC Pin Identification**

Pin #	Symbol	Function	Direction	Pin #	Symbol	Function	Direction
1-2	GND	Ground, GND		28	XTAL1	Crystal, Oscillator Clock	Input
3-4	P12-13	Port 1, Pins 2,3	In/Output	29-31	P31-33	Port 3, Pins 1,2,3	Input
5	P03	Port 0, Pin 3	In/Output	32	P34	Port 3, Pin 4	Output
6-10	P20-24	Port 2, Pins 0,1,2,3,4	In/Output	33	/AS	Address Strobe	Output
11	/DS	Data Strobe	Output	34	R//RL	ROM/ROMless Control	Input
12	N/C	Not Connected		35	/RESET	Reset	Input
13	R/W	Read/Write	Output	36	P35	Port 3, Pin 5	Output
14-16	P25-27	Port 2, Pins 5,6,7	In/Output	37	P37	Port 3, Pin 7	Output
17-19	P04-06	Port 0, Pins 4,5,6	In/Output	38	P36	Port 3, Pin 6	Output
20-21	P14-15	Port 1, Pins 4,5	In/Output	39	P30	Port 3, Pin 0	Input
22	P07	Port 0, Pin 7	In/Output	40-41	P00-01	Port 0, Pins 0,1	In/Output
23-24	V <sub>CC</sub>	Power Supply		42-43	P10-11	Port 1, Pins 0,1	In/Output
25-26	P16-17	Port 1, Pins 6,7	In/Output	44	P02	Port 0, Pin 2	In/Output
27	XTAL2	Crystal, Oscillator Clock	Output				

**PIN DESCRIPTION (Continued)**

**44-Pin QFP Pin Assignments**
**44-Pin QFP Pin Identification**

Pin #	Symbol	Function	Direction	Pin #	Symbol	Function	Direction
1-2	P05-06	Port 0, Pins 5,6	In/Output	21	P36	Port 3, Pin 6	Output
3-4	P14-15	Port 1, Pins 4,5	In/Output	22	P30	Port 3, Pin 0	Input
5	P07	Port 0, Pin 7	In/Output	23-24	P00-01	Port 0, Pins 0,1	In/Output
6-7	V <sub>CC</sub>	Power Supply		25-26	P10-11	Port 1, Pins 0,1	In/Output
8-9	P16-17	Port 1 Pins 6,7	In/Output	27	P02	Port 0, Pin 2	In/Output
10	XTAL2	Crystal, Oscillator Clock	Output	28-29	GND	Ground, GND	
11	XTAL1	Crystal, Oscillator Clock	Input	30-31	P12-13	Port 1, Pins 2,3	In/Output
12-14	P31-33	Port 3, Pins 1,2,3	Input	32	P03	Port 0, Pin 3	In/Output
15	P34	Port 3, Pin 4	Output	33-37	P20-24	Port 2, Pins 0,1,2,3,4	In/Output
16	/AS	Address Strobe	Output	38	/DS	Data Strobe	Output
17	R//RL	ROM/ROMless Control	Input	39	N/C	Not Connected	
18	/RESET	Reset	Input	40	R/W	Read/Write	Output
19	P35	Port 3, Pin 5	Output	41-43	P25-27	Port 2, Pins 5,6,7	In/Output
20	P37	Port 3, Pin 7	Output	44	P04	Port 0, Pin 4	In/Output

## ABSOLUTE MAXIMUM RATINGS

Parameter	Min	Max	Units
Ambient Temperature under Bias	-40	+105	C
Storage Temperature	-65	+150	C
Voltage on any Pin with Respect to $V_{SS}$ [Note 1]	-0.6	+7	V
Voltage on $V_{DD}$ Pin with Respect to $V_{SS}$	-0.3	+7	V
Voltage on XTAL1 and /RESET Pins with Respect to $V_{SS}$ [Note 2]	-0.6	$V_{DD}+1$	V
Total Power Dissipation		1.21	W
Maximum Allowable Current out of $V_{SS}$		220	mA
Maximum Allowable Current into $V_{DD}$		180	mA
Maximum Allowable Current into an Input Pin [Note 3]	-600	+600	$\mu$ A
Maximum Allowable Current into an Open-Drain Pin [Note 4]	-600	+600	$\mu$ A
Maximum Allowable Output Current Sunked by Any I/O Pin		25	mA
Maximum Allowable Output Current Sourced by Any I/O Pin		25	mA

### Notes:

- [1] This applies to all pins except XTAL pins and where otherwise noted.  
 [2] There is no input protection diode from pin to  $V_{DD}$ .  
 [3] This excludes XTAL pins.  
 [4] Device pin is not at an output Low state.

### Notice:

Stresses greater than those listed under Absolute Maximum Ratings may cause permanent damage to the device. This is a stress rating only; functional operation of the device at any condition above those indicated in the operational sections of these specifications is not implied. Exposure to absolute maximum rating conditions for an extended period may affect device reliability.

Total power dissipation should not exceed 1.21 W for the package. Power dissipation is calculated as follows:

$$\text{Total Power Dissipation} = V_{DD} \times [ I_{DD} - (\text{sum of } I_{OH}) ] \\ + \text{sum of } [ (V_{DD} - V_{OH}) \times I_{OH} ] \\ + \text{sum of } (V_{OL} \times I_{OL})$$

## STANDARD TEST CONDITIONS

The characteristics listed below apply for standard test conditions as noted. All voltages are referenced to Ground. Positive current flows into the referenced pin (Test Load).

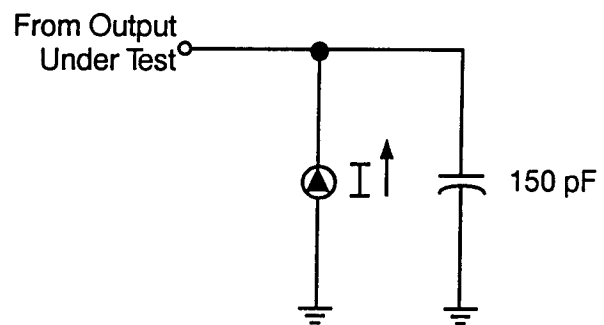

Test Load Diagram

## CAPACITANCE

$T_A = 25^\circ\text{C}$ ,  $V_{CC} = \text{GND} = 0\text{V}$ ,  $f = 1.0 \text{ MHz}$ ; unmeasured pins returned to GND.

Parameter	Min	Max
Input capacitance	0	12 pF
Output capacitance	0	12 pF
I/O capacitance	0	12 pF

**DC ELECTRICAL CHARACTERISTICS**

Sym	Parameter	V <sub>CC</sub> Note [3]	T <sub>A</sub> = 0°C to +70°C		Typical [1] @ 25°C		Conditions	Notes
			Min	Max		Units		
V <sub>CH</sub>	Clock Input High Voltage	3.0V	0.7 V <sub>CC</sub>	V <sub>CC</sub> +0.3	1.3	V	Driven by External Clock Generator	
		5.5V	0.7 V <sub>CC</sub>	V <sub>CC</sub> +0.3	2.5	V	Driven by External Clock Generator	
V <sub>CL</sub>	Clock Input Low Voltage	3.0V	GND-0.3	0.2 V <sub>CC</sub>	0.7	V	Driven by External Clock Generator	
		5.5V	GND-0.3	0.2 V <sub>CC</sub>	1.5	V	Driven by External Clock Generator	
V <sub>IH</sub>	Input High Voltage	3.0V	0.7 V <sub>CC</sub>	V <sub>CC</sub> +0.3	1.3	V		
		5.5V	0.7 V <sub>CC</sub>	V <sub>CC</sub> +0.3	2.5	V		
V <sub>IL</sub>	Input Low Voltage	3.0V	GND-0.3	0.2 V <sub>CC</sub>	0.7	V		
		5.5V	GND-0.3	0.2 V <sub>CC</sub>	1.5	V		
V <sub>OH</sub>	Output High Voltage	3.0V	V <sub>CC</sub> -0.4		3.1	V	I <sub>OH</sub> = -0.5 mA	
		5.5V	V <sub>CC</sub> -0.4		4.8	V	I <sub>OH</sub> = -0.5 mA	
V <sub>OH1</sub>	Output High Voltage	3.0V	V <sub>CC</sub> -0.4		3.1	V	I <sub>OH</sub> = -2.0 mA	[8]
		5.5V	V <sub>CC</sub> -0.4		4.8	V	I <sub>OH</sub> = -2.0 mA	[8]
V <sub>OL</sub>	Output Low Voltage	3.0V		0.6	0.3	V	I <sub>OL</sub> = 1.0 mA	
		5.5V		0.4	0.2	V	I <sub>OL</sub> = 1.0 mA	
V <sub>OL1</sub>	Output Low Voltage	3.0V		0.6	0.2	V	I <sub>OL</sub> = +4.0 mA	[8]
		5.0V		0.4	0.1	V	I <sub>OL</sub> = +4.0 mA	[8]
V <sub>OL2</sub>	Output Low Voltage	3.0V		1.2	0.5	V	I <sub>OL</sub> = +6 mA	[8]
		5.5V		1.2	0.5	V	I <sub>OL</sub> = +12 mA	[8]
V <sub>RH</sub>	Reset Input High Voltage	3.0V	.8 V <sub>CC</sub>	V <sub>CC</sub>	1.5	V		[7]
		5.5V	.8 V <sub>CC</sub>	V <sub>CC</sub>	2.1	V		[7]
V <sub>RL</sub>	Reset Input Low Voltage	3.0V	GND-0.3	0.2 V <sub>CC</sub>	1.1			[7]
		5.5V	GND-0.3	0.2 V <sub>CC</sub>	1.7			[7]
V <sub>OLR</sub>	Reset Output Low Voltage	3.0V		0.6	0.3	V	I <sub>OL</sub> = +1.0 mA	[7]
		5.5V		0.6	0.2	V	I <sub>OL</sub> = +1.0 mA	[7]
V <sub>OFFSET</sub>	Comparator Input Offset Voltage	3.0V		25	10	mV		
		5.5V		25	10	mV		
V <sub>ICR</sub>	Input Common Mode Voltage Range	3.0V	GND-0.3	V <sub>CC</sub> -1.0V		V		[10]
		5.5V	GND-0.3	V <sub>CC</sub> -1.0V		V		[10]
I <sub>IL</sub>	Input Leakage	3.0V	-1	2	0.064	μA	V <sub>IN</sub> = 0V, V <sub>CC</sub>	
		5.5V	-1	2	0.064	μA	V <sub>IN</sub> = 0V, V <sub>CC</sub>	
I <sub>OL</sub>	Output Leakage	3.0V	-1	2	0.114	μA	V <sub>IN</sub> = 0V, V <sub>CC</sub>	
		5.5V	-1	2	0.114	μA	V <sub>IN</sub> = 0V, V <sub>CC</sub>	
I <sub>IR</sub>	Reset Input Current	3.0V	-20	-130	-62	μA		
		5.5V	-20	-180	-112	μA		
I <sub>CC</sub>	Supply Current	3.0V		20	7	mA	@ 16 MHz	[4,5]
		5.5V		25	20	mA	@ 16 MHz	[4,5]
		3.0V		15	5	mA	@ 12 MHz	[4,5]
		5.5V		20	15	mA	@ 12 MHz	[4,5]

**DC ELECTRICAL CHARACTERISTICS** (Continued)

Sym	Parameter	V <sub>CC</sub> Note [3]	T <sub>A</sub> = 0°C to +70°C		Typical [1] @ 25°C		Units	Conditions	Notes
			Min	Max					
I <sub>CC1</sub>	Standby Current (Halt Mode)	3.0V		4.5	2.0	mA	V <sub>IN</sub> = 0V, V <sub>CC</sub> @ 16 MHz	[4,5]	
		5.5V		8	3.7	mA	V <sub>IN</sub> = 0V, V <sub>CC</sub> @ 16 MHz	[4,5]	
		3.0V		4	1.5	mA	V <sub>IN</sub> = 0V, V <sub>CC</sub> @ 12 MHz	[4,5]	
		5.5V		6	3.2	mA	V <sub>IN</sub> = 0V, V <sub>CC</sub> @ 12 MHz	[4,5]	
			3.0V		3.4	1.5	mA	Clock Divide by 16 @ 16 MHz	[4,5]
			5.5V		7.0	2.9	mA	Clock Divide by 16 @ 16 MHz	[4,5]
			3.0V		3	1.2	mA	Clock Divide by 16 @ 12 MHz	[4,5]
			5.5V		5	2.5	mA	Clock Divide by 16 @ 12 MHz	[4,5]
I <sub>CC2</sub>	Standby Current (Stop Mode)	3.0V		8	2	μA	V <sub>IN</sub> = 0V, V <sub>CC</sub> WDT is not Running	[6,11]	
		5.5V		10	4	μA	V <sub>IN</sub> = 0V, V <sub>CC</sub> WDT is not Running	[6,11]	
		3.0V		500	310	μA	V <sub>IN</sub> = 0V, V <sub>CC</sub> WDT is Running	[6,11]	
		5.5V		800	600	μA	V <sub>IN</sub> = 0V, V <sub>CC</sub> WDT is Running	[6,11]	
I <sub>ALL</sub>	Auto Latch Low Current	3.0V	0.7	8	2.4	μA	0V < V <sub>IN</sub> < V <sub>CC</sub>	[9]	
I <sub>ALH</sub>	Auto Latch High Current	5.5V	1.4	15	4.7	μA	0V < V <sub>IN</sub> < V <sub>CC</sub>	[9]	
		3.0V	-0.6	-5	-1.8	μA	0V < V <sub>IN</sub> < V <sub>CC</sub>	[9]	
		5.5V	-1	-8	-3.8	μA	0V < V <sub>IN</sub> < V <sub>CC</sub>	[9]	
T <sub>POR</sub>	Power On Reset	3.0V	3	24	10	mS			
		5.5V	2.0	13	4	mS			
V <sub>LV</sub>	Low Voltage Protection		2.05	2.95	2.6	V	6 MHz max INT CLK Freq.	[7]	

**Note:**

 [1] Typicals are at V<sub>CC</sub> = 5.0V and 3.3V.

[2] GND = 0V.

 [3] The V<sub>CC</sub> voltage spec. of 3.0V guarantees 3.3V ± 0.3V and the V<sub>DD</sub> voltage spec. of 5.5V guarantees 5.0V ± 0.5V.

[4] All outputs unloaded, I/O pins floating, inputs at rail.

[5] CL1 = CL2 = 10 pF.

 [6] Same as note [4] except inputs at V<sub>CC</sub>.

[7] Z86C40 only.

[8] STD Mode (not Low-EMI Mode).

[9] Auto Latch (mask option) selected.

[10] For analog comparator inputs when analog comparators are enabled.

[11] Clock must be forced Low, when XTAL1 is clock driven and XTAL2 is floating.

**DC ELECTRICAL CHARACTERISTICS**

Sym	Parameter	V <sub>CC</sub> Note [3]	T <sub>A</sub> = -40°C to 105°C		Typical [1]	Units	Conditions	Notes
			Min	Max	@ 25°C			
V <sub>CH</sub>	Clock Input High Voltage	3.0V	0.7 V <sub>CC</sub>	V <sub>CC</sub> +0.3	1.3	V	Driven by External Clock Generator	
		5.5V	0.7 V <sub>CC</sub>	V <sub>CC</sub> +0.3	2.5	V	Driven by External Clock Generator	
V <sub>CL</sub>	Clock Input Low Voltage	3.0V	GND-0.3	0.2 V <sub>CC</sub>	0.7	V	Driven by External Clock Generator	
		5.5V	GND-0.3	0.2 V <sub>CC</sub>	1.5	V	Driven by External Clock Generator	
V <sub>IH</sub>	Input High Voltage	3.0V	0.7 V <sub>CC</sub>	V <sub>CC</sub> +0.3	1.3	V		
		5.5V	0.7 V <sub>CC</sub>	V <sub>CC</sub> +0.3	2.5	V		
V <sub>IL</sub>	Input Low Voltage	3.0V	GND-0.3	0.2 V <sub>CC</sub>	0.7	V		
		5.5V	GND-0.3	0.2 V <sub>CC</sub>	1.5	V		
V <sub>OH</sub>	Output High Voltage	3.0V	V <sub>CC</sub> -0.4		3.1	V	I <sub>OH</sub> = -0.5 mA	
		5.5V	V <sub>CC</sub> -0.4		4.8	V	I <sub>OH</sub> = -0.5 mA	
V <sub>OH1</sub>	Output High Voltage	3.0V	V <sub>CC</sub> -0.4		3.1	V	I <sub>OH</sub> = -2.0 mA	[8]
		5.5V	V <sub>CC</sub> -0.4		4.8	V	I <sub>OH</sub> = -2.0 mA	[8]
V <sub>OL</sub>	Output Low Voltage	3.0V		0.6	0.3	V	I <sub>OL</sub> = 1.0 mA	
		5.5V		0.4	0.2	V	I <sub>OL</sub> = 1.0 mA	
V <sub>OL1</sub>	Output Low Voltage	3.0V		0.6	0.2	V	I <sub>OL</sub> = +4.0 mA	[8]
		5.0V		0.4	0.1	V	I <sub>OL</sub> = +4.0 mA	[8]
V <sub>OL2</sub>	Output Low Voltage	3.0V		1.2	0.5	V	I <sub>OL</sub> = +6 mA	[8]
		5.5V		1.2	0.5	V	I <sub>OL</sub> = +12 mA	[8]
V <sub>RH</sub>	Reset Input High Voltage	3.0V	.8 V <sub>CC</sub>	V <sub>CC</sub>	1.5	V		[7]
		5.5V	.8 V <sub>CC</sub>	V <sub>CC</sub>	2.1	V		[7]
V <sub>RL</sub>	Reset Input Low Voltage	3.0V	GND-0.3	0.2 V <sub>CC</sub>	1.1			[7]
		5.5V	GND-0.3	0.2 V <sub>CC</sub>	1.7			[7]
V <sub>OLR</sub>	Reset Output Low Voltage	3.0V		0.6	0.4	V	I <sub>OL</sub> = +1.0 mA	[7]
		5.5V		0.6	0.3	V	I <sub>OL</sub> = +1.0 mA	[7]
V <sub>OFFSET</sub>	Comparator Input Offset Voltage	3.0V		25	10	mV		
		5.5V		25	10	mV		
V <sub>ICR</sub>	Input Common Mode Voltage Range	3.0V	GND-0.3	V <sub>CC</sub> -1.5V		V		[10]
		5.5V	GND-0.3	V <sub>CC</sub> -1.5V		V		[10]
I <sub>IL</sub>	Input Leakage	3.0V	-1	2	<1	μA	V <sub>IN</sub> = 0V, V <sub>CC</sub>	
		5.5V	-1	2	<1	μA	V <sub>IN</sub> = 0V, V <sub>CC</sub>	
I <sub>OL</sub>	Output Leakage	3.0V	-1	2	<1	μA	V <sub>IN</sub> = 0V, V <sub>CC</sub>	
		5.5V	-1	2	<1	μA	V <sub>IN</sub> = 0V, V <sub>CC</sub>	
I <sub>IR</sub>	Reset Input Current	3.0V	-18	-130	-62	μA		
		5.5V	-18	-180	-112	μA		
I <sub>CC</sub>	Supply Current	3.0V		20	7	mA	@ 16 MHz	[4,5]
		5.5V		25	20	mA	@ 16 MHz	[4,5]
		3.0V		15	5	mA	@ 12 MHz	[4,5]
		5.5V		20	15	mA	@ 12 MHz	[4,5]

**DC ELECTRICAL CHARACTERISTICS** (Continued)

Sym	Parameter	V <sub>CC</sub> Note [3]	T <sub>A</sub> = -40°C to 105°C		Typical [1]	Units	Conditions	Notes
			Min	Max	@ 25°C			
I <sub>CC1</sub>	Standby Current (Halt Mode)	3.0V	4.5	2.0	mA	V <sub>IN</sub> = 0V, V <sub>CC</sub> @ 16 MHz	[4,5]	
		5.5V	8	3.7	mA	V <sub>IN</sub> = 0V, V <sub>CC</sub> @ 16 MHz	[4,5]	
		3.0V	4	1.5	mA	V <sub>IN</sub> = 0V, V <sub>CC</sub> @ 12 MHz	[4,5]	
		5.5V	6	3.2	mA	V <sub>IN</sub> = 0V, V <sub>CC</sub> @ 12 MHz	[4,5]	
		3.0V	3.4	1.5	mA	Clock Divide by 16 @ 16 MHz	[4,5]	
		5.5V	7.0	2.9	mA	Clock Divide by 16 @ 16 MHz	[4,5]	
		3.0V	3	1.2	mA	Clock Divide by 16 @ 12 MHz	[4,5]	
		5.5V	5	2.5	mA	Clock Divide by 16 @ 12 MHz	[4,5]	
I <sub>CC2</sub>	Standby Current (Stop Mode)	3.0V	8	2	μA	V <sub>IN</sub> = 0V, V <sub>CC</sub> WDT is not Running	[6,11]	
		5.5V	10	4	μA	V <sub>IN</sub> = 0V, V <sub>CC</sub> WDT is not Running	[6,11]	
		3.0V	600	310	μA	V <sub>IN</sub> = 0V, V <sub>CC</sub> WDT is Running	[6,11]	
		5.5V	1000	600	μA	V <sub>IN</sub> = 0V, V <sub>CC</sub> WDT is Running	[6,11]	
I <sub>ALL</sub>	Auto Latch Low Current	3.0V	0.7	10	2.4	μA	0V < V <sub>IN</sub> < V <sub>CC</sub>	[9]
		5.5V	1.4	20	4.7	μA	0V < V <sub>IN</sub> < V <sub>CC</sub>	[9]
I <sub>ALH</sub>	Auto Latch High Current	3.0V	-0.6	-7	-1.8	μA	0V < V <sub>IN</sub> < V <sub>CC</sub>	[9]
		5.5V	-1.0	-10	-3.8	μA	0V < V <sub>IN</sub> < V <sub>CC</sub>	[9]
T <sub>POR</sub>	Power On Reset	3.0V	3.0	25	7	mS		
		5.5V	2.0	14	4	mS		
V <sub>LV</sub>	Low Voltage Protection		1.8	3.3	2.6	V	4 MHz max INT CLK Freq.	

**Note:**

 [1] Typicals are at V<sub>CC</sub> = 5.0V and 3.3V.

[2] GND=0V.

 [3] The V<sub>CC</sub> voltage spec. of 3.0V guarantees 3.3V ± 0.3V and the V<sub>DD</sub> voltage spec. of 5.5V guarantees 5.0V ± 0.5V.

[4] All outputs unloaded, I/O pins floating, inputs at rail.

[5] CL1= CL2 = 100pF.

 [6] Same as note [4] except inputs at V<sub>CC</sub>.

[7] Z86C40 only.

[8] STD Mode (not Low EMI Mode).

[9] Auto Latch (mask option) selected.

[10] For analog comparator inputs when analog comparators are enabled.

[11] Clock must be forced Low, when XTAL1 is clock driven and XTAL2 is floating.

[7] Z86C40 only.

**AC CHARACTERISTICS**

External I/O or Memory Read and Write Timing Diagram (Z86C40 Only)

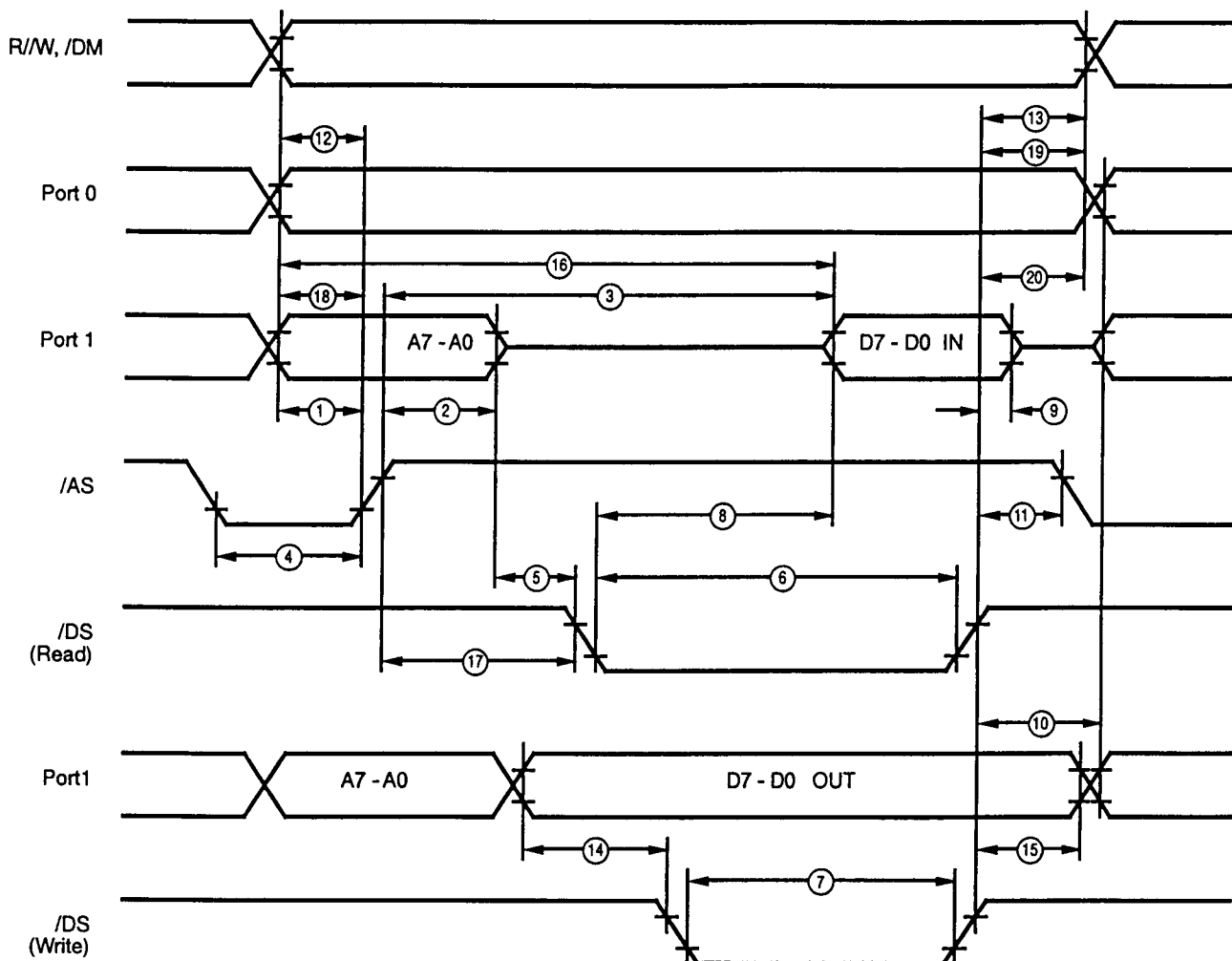

**External I/O or Memory Read/Write Timing  
(Z86C40 Only)**

**AC CHARACTERISTICS**

External I/O or Memory Read and Write Timing Table (Z86C40 Only)

(SCLK/TCLK = XTAL/2)

No	Symbol	Parameter	Note [3] V <sub>CC</sub>	T <sub>A</sub> = -40°C to 105°C		T <sub>A</sub> = -40°C to +105°C		Units	Notes	
				12 MHz	16 MHz	12 MHz	16 MHz			
1	TdA(AS)	Address Valid to /AS Rise Delay	3.0	35	25	35	25	ns	[2]	
			5.5	35	25	35	25	ns		
2	TdAS(A)	/AS Rise to Address Float Delay	3.0	45	35	45	35	ns	[2]	
			5.5	45	35	45	35	ns		
3	TdAS(DR)	/AS Rise to Read Data Req'd Valid	3.0		250		250	180	ns	[1,2]
			5.5		250		250	180	ns	
4	TwAS	/AS Low Width	3.0	55	40	55	40	ns	[2]	
			5.5	55	40	55	40	ns		
5	TdAS(DS)	Address Float to /DS Fall	3.0	0	0	0	0	ns		
			5.5	0	0	0	0	ns		
6	TwDSR	/DS (Read) Low Width	3.0	200	135	200	135	ns	[1,2]	
			5.5	200	135	200	135	ns		
7	TwDSW	/DS (Write) Low Width	3.0	110	80	110	80	ns	[1,2]	
			5.5	110	80	110	80	ns		
8	TdDSR(DR)	/DS Fall to Read Data Req'd Valid	3.0		150		150	75	ns	[1,2]
			5.5		150		150	75	ns	
9	ThDR(DS)	Read Data to /DS Rise Hold Time	3.00	0	0	0	0	ns	[2]	
			5.5	0	0	0	0	ns		
10	TdDS(A)	/DS Rise to Address Active Delay	3.0	45	50	45	50	ns	[2]	
			5.5	55	50	55	50	ns		
11	TdDS(AS)	/DS Rise to /AS Fall Delay	3.0	30	35	30	35	ns	[2]	
			5.5	45	35	45	55	ns		
12	TdR/W(AS)	R/W Valid to /AS Rise Delay	3.0	45	25	45	25	ns	[2]	
			5.5	45	25	45	25	ns		
13	TdDS(R/W)	/DS Rise to R/W Not Valid	3.0	45	35	45	35	ns	[2]	
			5.5	45	35	45	35	ns		
14	TdDW(DSW)	Write Data Valid to /DS Fall (Write) Delay	3.0	55	25	55	25	ns	[2]	
			5.5	55	25	55	25	ns		
15	TdDS(DW)	/DS Rise to Write Data Not Valid Delay	3.0	45	35	45	35	ns	[2]	
			5.5	45	35	45	35	ns		
16	TdA(DR)	Address Valid to Read Data Req'd Valid	3.0		310		310	230	ns	[1,2]
			5.5		310		310	230	ns	
17	TdAS(DS)	/AS Rise to /DS Fall Delay	3.0	65	45	65	45	ns	[2]	
			5.5	65	45	65	45	ns		
18	TdDM(AS)	/DM Valid to /AS Fall Delay	3.0	35	30	35	30	ns	[2]	
			5.5	35	30	35	30	ns		
19	TdDS(DM)	/DS Rise to DM Valid Delay	3.0	45	35	45	35	ns		
			5.5	45	35	45	35	ns		
20	ThDS(AS)	/DS Valid to Address Valid Hold Time	3.0	45	35	45	35	ns		
			5.5	45	35	45	35	ns		

**Notes:**

[1] When using extended memory timing add 2 TpC.

[2] Timing numbers given are for minimum TpC.

 [3] The V<sub>CC</sub> voltage specification of 3.0V guarantees 3.3V ± 0.3V, and the V<sub>DD</sub> voltage specification of 5.5V guarantees 5.0V ± 0.5V.

**Standard Test Load**

 All timing references use 0.7 V<sub>CC</sub> for a logic 1 and 0.2 V<sub>CC</sub> for a logic 0. For Standard Mode (not Low-EMI Mode for outputs) with SMR D1 = 0, D0 = 0.

# AC ELECTRICAL CHARACTERISTICS

## Additional Timing Diagram

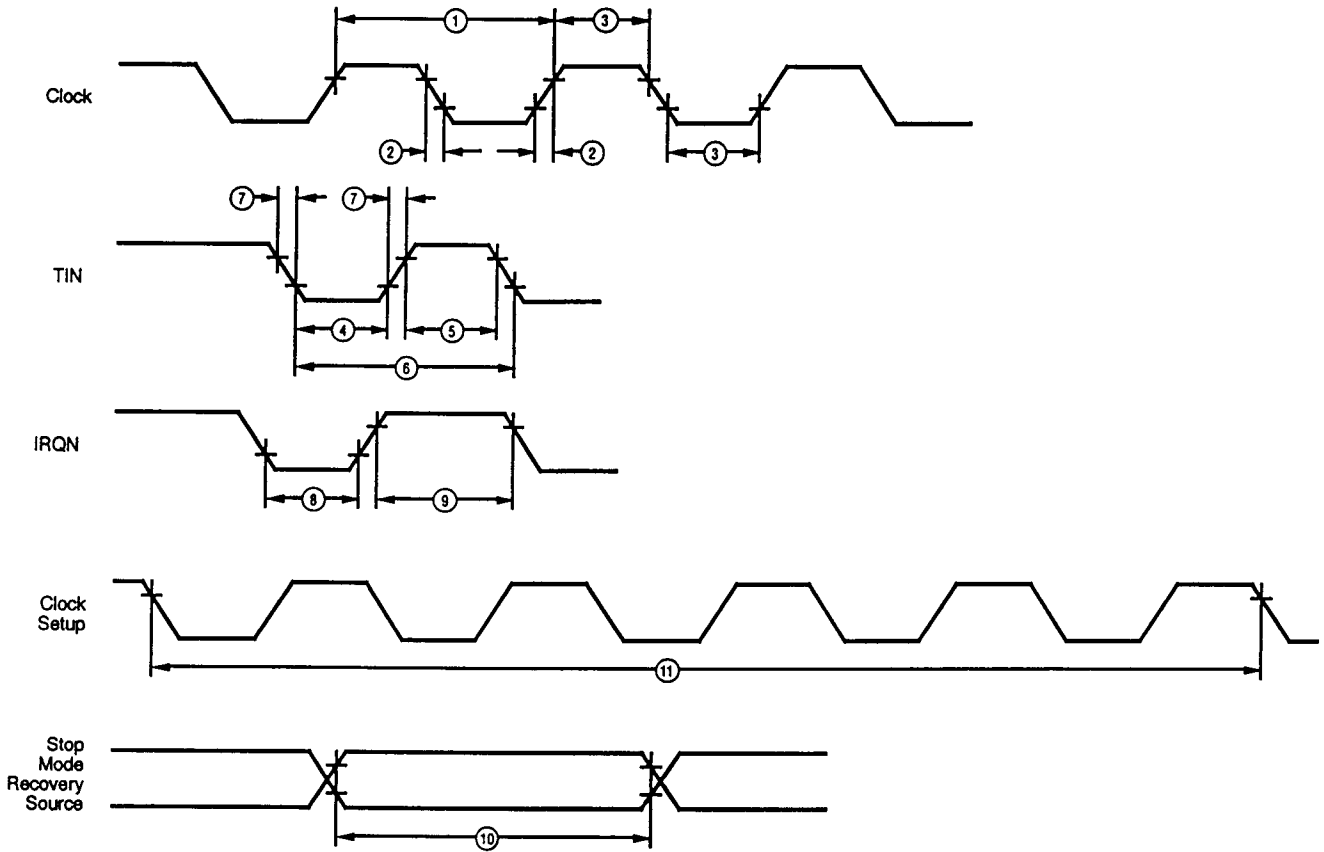

Additional Timing

## AC ELECTRICAL CHARACTERISTICS

Additional Timing Table (Divide-By-One Mode)

		$T_A = 0^\circ\text{C to } +70^\circ\text{C}$		$T_A = 40^\circ\text{C to } +105^\circ\text{C}$					
No	Symbol	Parameter	$V_{CC}$ Note [6]	4 MHz Min	4 MHz Max	4 MHz Min	4 MHz Max	Units	Notes
1	$T_{pC}$	Input Clock Period	3.0V	250	DC	250	DC	ns	[1,7,8]
			5.5V	250	DC	250	DC	ns	[1,7,8]
2	$T_{rC}, T_{fC}$	Clock Input Rise & Fall Times	3.0V		25		25	ns	[1,7,8]
			5.5V		25		25	ns	[1,7,8]
3	$T_{wC}$	Input Clock Width	3.0V	100		100		ns	[1,7,8]
			5.5V	100		100		ns	[1,7,8]
4	$T_{wTinL}$	Timer Input Low Width	3.0V	100		100		ns	[1,7,8]
			5.5V	70		70		ns	[1,7,8]
5	$T_{wTinH}$	Timer Input High Width	3.0V	5TpC		5TpC			[1,7,8]
			5.5V	5TpC		5TpC			[1,7,8]
6	$T_{pTin}$	Timer Input Period	3.0V	8TpC		8TpC			[1,7,8]
			5.5V	8TpC		8TpC			[1,7,8]
7	$T_{rTin}, T_{fTin}$	Timer Input Rise & Fall Timer	3.0V		100		100	ns	[1,7,8]
			5.5V		100		100	ns	[1,7,8]
8A	$T_{wIL}$	Int. Request Low Time	3.0V	100		100		ns	[1,2,7,8]
			5.5V	70		70		ns	[1,2,7,8]
8B	$T_{wIL}$	Int. Request Low Time	3.0V	5TpC		5TpC			[1,3,7,8]
			5.5V	5TpC		5TpC			[1,3,7,8]
9	$T_{wIH}$	Int. Request Input High Time	3.0V	5TpC		5TpC			[1,2,7,8]
			5.5V	5TpC		5TpC			[1,2,7,8]
10	$T_{wsm}$	STOP Mode Recovery Width Spec	3.0V	12		12		ns	[4,8]
			5.5V	12		12		ns	[4,8]
11	$T_{ost}$	Oscillator Start-up Time	3.0V		5TpC		5TpC		[4,8,9]
			5.5V		5TpC		5TpC		[4,8,9]

**Notes:**

- [1] Timing Reference uses  $0.7 V_{CC}$  for a logic 1 and  $0.2 V_{CC}$  for a logic 0.
- [2] Interrupt request via Port 3 (P31-P33).
- [3] Interrupt request via Port 3 (P30).
- [4] SMR-D5 = 1, POR STOP Mode Delay is on.
- [5] Reg. WDTMR.
- [6] The  $V_{CC}$  voltage specification of 3.0V guarantees  $3.3V \pm 0.3V$ , and the  $V_{DD}$  voltage specification of 5.5V guarantees  $5.0V \pm 0.5V$ .
- [7] SMR D1 = 0.
- [8] Maximum frequency for internal system clock is 4 MHz when using XTAL divide-by-one mode.
- [9] For RC and LC oscillator, and for oscillator driven by clock driver.

## AC ELECTRICAL CHARACTERISTICS

### Additional Timing Table

No	Symbol	Parameter	V <sub>cc</sub> Note [6]	T <sub>A</sub> = -40°C to +105°C		T <sub>A</sub> = 0°C to +70°C		Units	Notes
				16 MHz		12 MHz			
				Min	Max	Min	Max		
1	TpC	Input Clock Period	3.0V	62.5	DC	83	DC	ns	[1,7,8]
			5.5V	62.5	DC	83	DC	ns	[1,7,8]
2	TrC,TfC	Clock Input Rise & Fall Times	3.0V		15		15	ns	[1,7,8]
			5.5V		15		15	ns	[1,7,8]
3	TwC	Input Clock Width	3.0V	31		26		ns	[1,7,8]
			5.5V	31		26		ns	[1,7,8]
4	TwTinL	Timer Input Low Width	3.0V	100		100		ns	[1,7,8]
			5.5V	70		70		ns	[1,7,8]
5	TwTinH	Timer Input High Width	3.0V	5TpC		5TpC			[1,7,8]
			5.5V	5TpC		5TpC			[1,7,8]
6	TpTin	Timer Input Period	3.0V	8TpC		8TpC			[1,7,8]
			5.5V	8TpC		8TpC			[1,7,8]
7	TrTin, TfTin	Timer Input Rise & Fall Timer	3.0V		100		100	ns	[1,7,8]
			5.5V		100		100	ns	[1,7,8]
8A	TwIL	Int. Request Low Time	3.0V	100		100		ns	[1,2,7,8]
			5.5V	70		70		ns	[1,2,7,8]
8B	TwIL	Int. Request Low Time	3.0V	5TpC		5TpC			[1,3,7,8]
			5.5V	5TpC		5TpC			[1,3,7,8]
9	TwIH	Int. Request Input High Time	3.0V	5TpC		5TpC			[1,2,7,8]
			5.5V	5TpC		5TpC			[1,2,7,8]
10	Twsm	STOP Mode Recovery Width Spec	3.0V	12		12		ns	[4,8]
			5.5V	12		12		ns	[4,8]
11	Tost	Oscillator Start-up Time	3.0V		5TpC		5TpC		[4,8]
			5.5V		5TpC		5TpC		[4,8]
12	Twdt	Watch-Dog Timer Delay Time Before Refresh	3.0V	10		10		ms	D0 = 0 [5,11]
			5.5V	5		5.0		ms	D1 = 0 [5,11]
			3.0V	20		20		ms	D0 = 1 [5,11]
			5.5V	10		10		ms	D1 = 0 [5,11]
			3.0V	40		40		ms	D0 = 0 [5,11]
			5.5V	20		20		ms	D1 = 1 [5,11]
			3.0V	160		160		ms	D0 = 1 [5,11]
			5.5V	80		80		ms	D1 = 1 [5,11]

**Notes:**

- [1] Timing Reference uses 0.7 V<sub>cc</sub> for a logic 1 and 0.2 V<sub>cc</sub> for a logic 0.
- [2] Interrupt request via Port 3 (P31-P33).
- [3] Interrupt request via Port 3 (P30).
- [4] SMR-D5 = 1, POR STOP Mode Delay is on.
- [5] Reg. WDTMR.
- [6] The V<sub>cc</sub> voltage spec. of 3.0V guarantees 3.3V ± 0.3V and the V<sub>DD</sub> voltage spec. of 5.5V guarantees 5.0V ± 0.5V.
- [7] SMR D1 = 0.
- [8] Maximum frequency for internal system clock is 4 MHz when using XTAL divide-by-one mode.
- [9] For RC and LC oscillator, and for oscillator driven by clock driver.
- [10] Standard Mode (not Low EMI output ports).
- [11] Using internal RC.

# AC ELECTRICAL CHARACTERISTICS

## Handshake Timing Diagrams

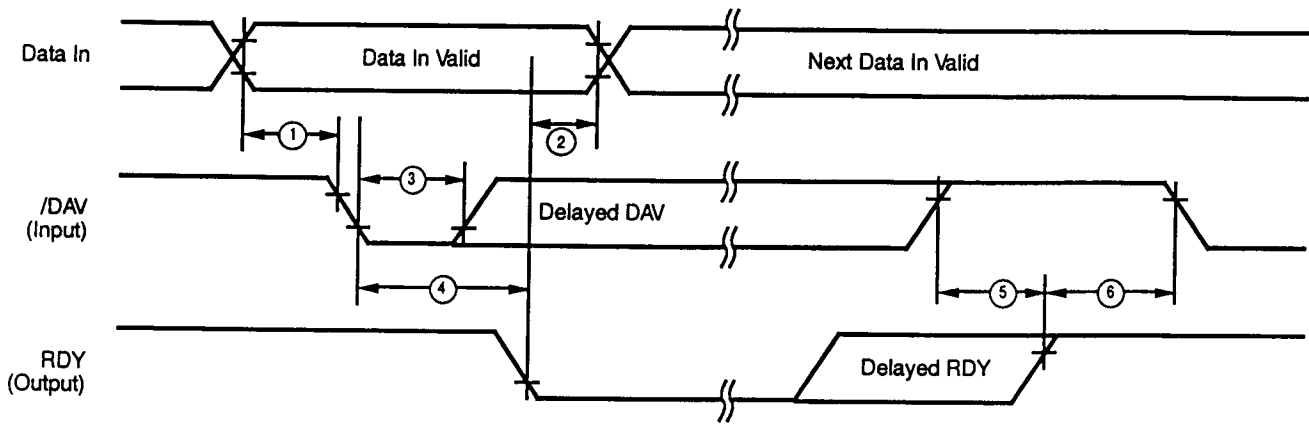

**Input Handshake Timing**

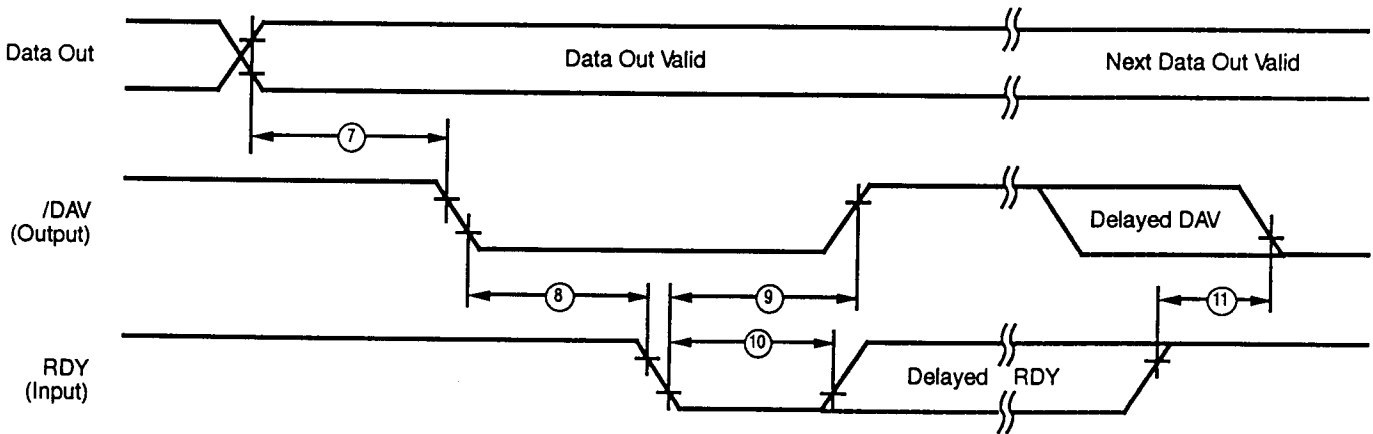

**Output Handshake Timing**

## PRECAUTIONS

1. When in ROM Protect Mode, and executing out of *External Program Memory*, instructions LDC, LDCI, LDE, and LDEI *cannot* read Internal Program Memory.
2. When in ROM Protect Mode, and executing out of *Internal Program Memory*, instructions LDC, LDCI, LDE, and LDEI *can* read Internal Program Memory.
3. Low EMI is 25 percent of standard pull-down output driver and 25 percent of standard pull-up output driver.
4. The Port 3 outputs are reset to High State after Reset, except after Stop-Mode Recovery, at which time the outputs remain in the last state.
5. Extended timing is operable.
6. P0/P1/P2/P3 is Low-EMI software programmable.
7. P0/P1/P2 is software programmable for open-drain.
8. Expanded register PCON is Write Only.
9. WDTMR is writeable only within the first 60 system clocks after Reset. Afterward, the WDTMR is write protected.
10. Device functions down to the  $V_{LV}$  threshold. At temperatures less than 25°C, the  $V_{LV}$  threshold will rise to a maximum  $V_{DD}$  of 3.3V.
11. Registers FE Hex (SPH) and FF Hex (SPL) are set to 00 Hex after any reset.
12. When Low EMI OSC is selected (PCON Reg Bit D7=0), the output drive of /DS, /AS, and R/W will also be in low EMI mode.
13. P01M Reg Bit D4,D3 must be set to 00Hex for Z86C30/31/32.

---

**Pre-Characterization Product:**

The product represented by this CPS is newly introduced and Zilog has not completed the full characterization of the product. The CPS states what Zilog knows about this product at this time, but additional features or non-conformance with some aspects of the CPS may be found,

either by Zilog or its customers in the course of further application and characterization work. In addition, Zilog cautions that delivery may be uncertain at times, due to start-up yield issues.

---

© 1996 by Zilog, Inc. All rights reserved. No part of this document may be copied or reproduced in any form or by any means without the prior written consent of Zilog, Inc. The information in this document is subject to change without notice. Devices sold by Zilog, Inc. are covered by warranty and patent indemnification provisions appearing in Zilog, Inc. Terms and Conditions of Sale only. Zilog, Inc. makes no warranty, express, statutory, implied or by description, regarding the information set forth herein or regarding the freedom of the described devices from intellectual property infringement. Zilog, Inc. makes no warranty of merchantability or fitness for any purpose. Zilog, Inc. shall not be responsible for any errors that may appear in this document. Zilog, Inc. makes no commitment to update or keep current the information contained in this document.

Zilog's products are not authorized for use as critical components in life support devices or systems unless a specific written agreement pertaining to such intended use is executed between the customer and Zilog prior to use. Life support devices or systems are those which are intended for surgical implantation into the body, or which sustains life whose failure to perform, when properly used in accordance with instructions for use provided in the labeling, can be reasonably expected to result in significant injury to the user.

Zilog, Inc. 210 East Hacienda Ave.  
Campbell, CA 95008-6600  
Telephone (408) 370-8000  
FAX 408 370-8056  
Internet: <http://www.zilog.com>

## Looking for pricing, stock, or lifecycle information?

Click below to explore more details on WIN SOURCE:

 [View Z86C3012PSCR4457 on WIN SOURCE](#)

 [Zilog Information](#)

## Optimize Your Supply Chain with WIN SOURCE Solutions

-  Global Sourcing Solution
-  Obsolete Management
-  Cost Control Management
-  Shortage Management
-  Alternative Solution
-  Excess Inventory Management