



**THE DATASHEET OF
TLE4954CE4807BAMA1**



TLE4954C/51C

Differential Hall Effect Transmission Speed Sensors

TLE4954C
TLE4954C-E1
TLE4954C-E2
TLE4954C-E4
TLE4954CB
TLE4954CB-E1
TLE4954CB-E2
TLE4951C
TLE4951CB

Product Information

2013-10-15

Table of Contents

	Table of Contents	2
1	General	3
1.1	Target Application	3
1.2	Features	3
2	Functional Description	4
2.1	General	4
2.2	Sensor assembly	4
2.2.1	Vibration Suppression	6
3	Specifications	6
3.1	Operating Range	6
3.2	Electrical Characteristics	6
3.3	ESD Robustness	6
3.4	Timing Characteristics	7
3.5	Operation characteristics - TLE4951CB, TLE4954CB, TLE4954CB-E1, TLE4954CB-E2	9
3.6	Reference Target Wheel for TLE4951CB, TLE4954CB, TLE4954CB-E1, TLE4954CB-E2	10
4	Package Information	11
4.1	Package Information TLE4954C, TLE4954C-E1, TLE4954C-E2, TLE4951C	11
4.2	Package Information TLE4951CB, TLE4954CB, TLE4954CB-E1, TLE4954CB-E2	13

1 General

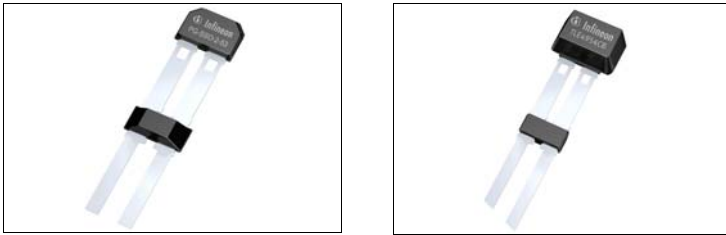

1.1 Target Application

TLE4954C/51C is an integrated differential Hall effect sensor for transmission applications with two wire PWM current interface. Its basic function is to provide information about rotational speed and direction of rotation to the transmission control unit. TLE4954C/51C includes a sophisticated algorithm which actively suppresses vibration while keeping excellent airgap performance. Infineon also offers customers the possibility to purchase sensors with already attached back bias magnets (CB versions).

1.2 Features

Product Name	CCW ¹⁾	CW ²⁾	Pre Low time	Direction signal	Speed
TLE4954C	60 µs	120 µs	30 µs		30 µs above 1kHz
TLE4954C-E1	45 µs	180 µs	30 µs	Direction signal up to 8kHz typ. (ccw) and 12kHz typ. (cw)	none
TLE4954C-E2	45 µs	90 µs	30 µs		180 µs
TLE4954C-E4	45 µs	90 µs	15 µs	Direction signal up to 8kHz min. (ccw) and 12kHz min. (cw)	30 µs
TLE4951C	Speed signal only				

All sensors with a B in the product name have an integrated back bias magnet.

TLE4954CB	60 µs	120 µs	30 µs		30 µs above 1kHz
TLE4954CB-E1	45 µs	180 µs	30 µs	Direction signal up to 8kHz typ. (ccw) and 12kHz typ. (cw)	none
TLE4954CB-E2	45 µs	90 µs	30 µs		180 µs
TLE4951CB	Speed signal only				

1) Rotation direction left 2) Rotation direction right

Note: More specific information about the timer-characteristics can be found in the FAQ for TLE4954C/51C.

Product Name	Order Code	Marking	Package
TLE4954C	SP000848260	54C00A	PG-SSO-2-53
TLE4954C-E1	SP000848264	54CE1A	PG-SSO-2-53
TLE4954C-E2	SP000848268	54CE2A	PG-SSO-2-53
TLE4954C-E4	SP001050144	54CE4A	PG-SSO-2-53
TLE4954CB	SP000913564	54CB0A	PG-SSOM-2-11
TLE4954CB-E1	SP000913568	54CB1A	PG-SSOM-2-11
TLE4954CB-E2	SP000913572	54CB2A	PG-SSOM-2-11
TLE4951C	SP000848256	51C00A	PG-SSO-2-53
TLE4951CB	SP000913560	51CB0A	PG-SSOM-2-11

2 Functional Description

2.1 General

The differential Hall sensor IC detects the motion of tooth and magnet encoder applications. To detect the motion of ferromagnetic objects, the magnetic field must be provided by a back biasing permanent magnet. Either south or north pole of the magnet can be attached to the rear unmarked side of the IC package. The magnetic measurement is based on three equally spaced Hall elements, integrated on the IC. Both magnetic and mechanical offsets are cancelled by a self calibration algorithm. The sensor includes a current output PWM protocol.

2.2 Sensor assembly

Sensor and back bias magnet can be applied in the following ways:

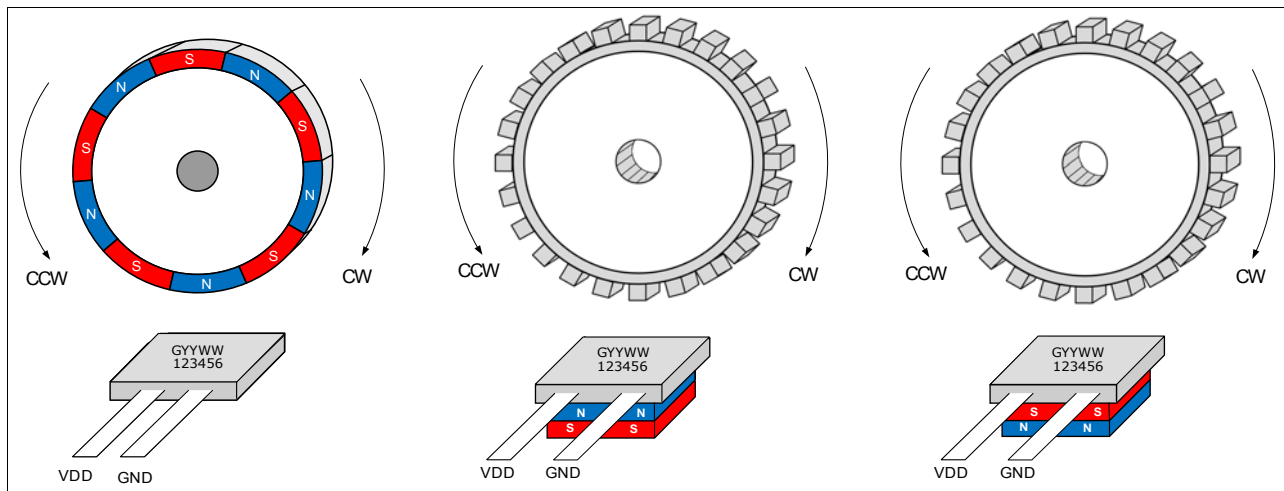

Figure 2-1 Sensor assembly and definition of rotating directions

The output signals for a south biased sensor with a magnetic encoder and ferromagnetic tooth wheel will be issued in the following way.

The tooth wheel is rotating in clockwise above the sensor. The output pulse will be issued by reaching the hysteresis levels after the pre low time. For a tooth wheel with ideal pitch (tooth to tooth) 5mm the direction signal achieves a phase shift of 90° compared to the speed signal.

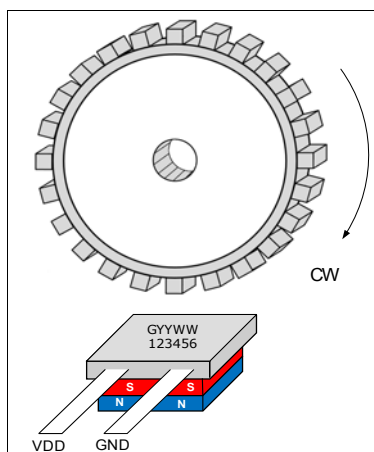

Figure 2-2 Clockwise rotation; south biased sensor

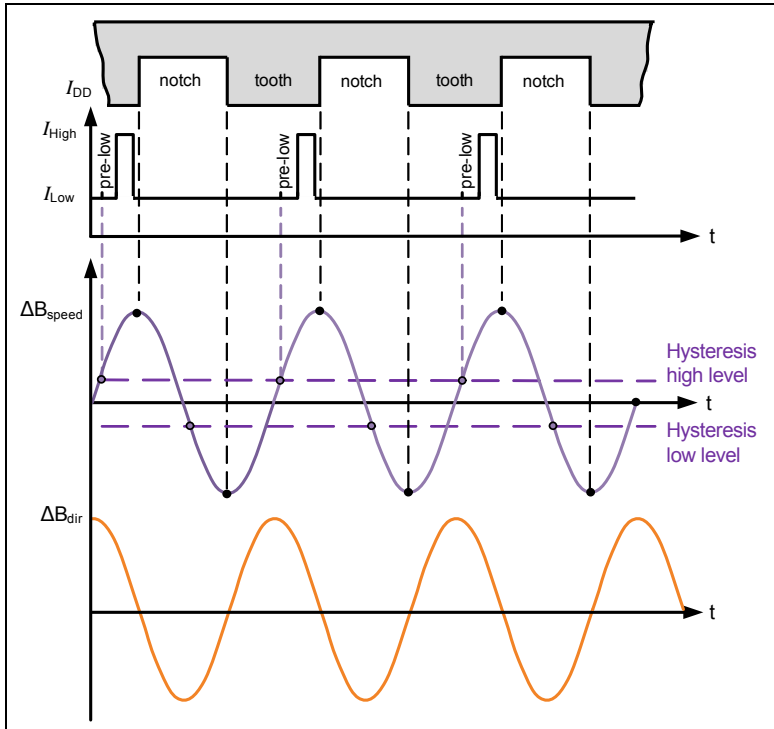

Figure 2-3 Tooth wheel vs. sensor output signal in clockwise rotation; south biased sensor - TLE4954C, TLE4954C-E1, TLE4954C-E2, TLE4954C-E4

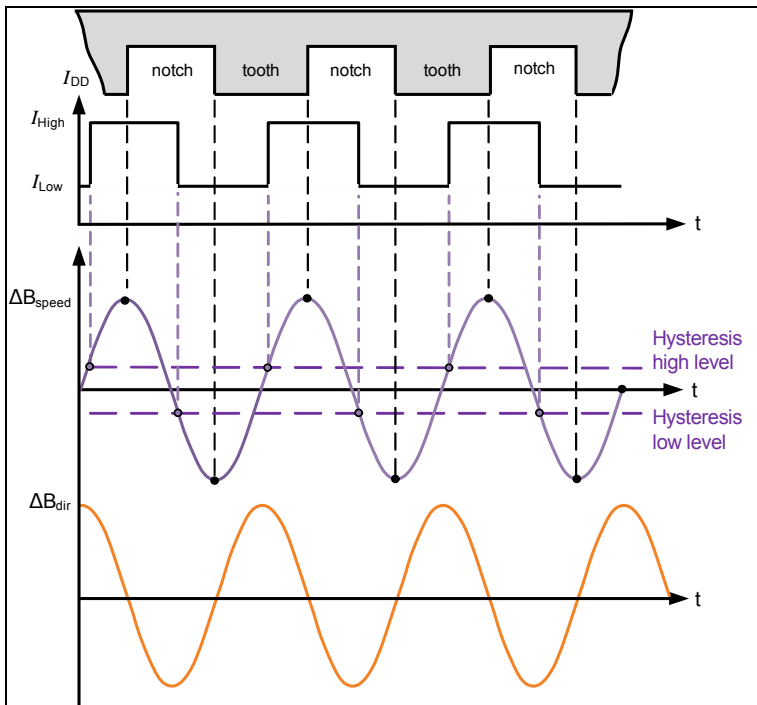

Figure 2-4 Tooth wheel vs. sensor output signal in clockwise rotation; south biased sensor - TLE4951C

2.2.1 Vibration Suppression

TLE4954C offers two different kinds of vibration suppression:

The magnetic signal amplitude and the direction information are used for detection of parasitic magnetic signals. Unwanted magnetic signal can be caused by angular or airgap vibrations. If an input signal is identified as a vibration the output pulse will be suppressed.

- Vibration suppression via hysteresis. This is available after power on
- Vibration suppression via direction detection. This is available after start up calibration is performed.

3 Specifications

3.1 Operating Range

Table 3-1 Operating Range

Parameter	Symbol	Values			Unit	Note / Test Condition
		Min.	Typ.	Max.		
Supply voltage	V_{DDIC}	4		20	V	Directly on the IC leads
Operation junction temperature	T_j	-40		170	°C	
Speed signal range	$\Delta B_{speed,range}$	-120		120	mT	

3.2 Electrical Characteristics

Table 3-2 Electrical Characteristics

Parameter	Symbol	Values			Unit	Note / Test Condition
		Min.	Typ.	Max.		
Supply current low	I_{Low}		7		mA	
Supply current high	I_{High}		14		mA	
Output rise/fall slew rate	SR_r, SR_f		17		mA/μs	Valid for t_r and t_f , between 10% and 90% value $R_M=75 \Omega, T_j<175 \text{ }^\circ\text{C}$
Reset voltage	$V_{DD \text{ Reset}}$		3.7	4	V	
Power on time	t_{ON}			1	ms	$V_{DD} > 4V$
Period Jitter, $f \leq 2500 \text{ Hz}$	$S_{Jit-far}, T_j \leq 150 \text{ }^\circ\text{C}$		3.2		%	$\pm 3\sigma$ value, $V_{DD}=12 \text{ V}, \Delta B_{speed} \geq 4 \text{ mT}$ peak to peak
Period Jitter, $2500\text{Hz} < f < 12\text{kHz}$	$S_{Jit-far}, T_j \leq 150 \text{ }^\circ\text{C}$		4.2		%	$\pm 3\sigma$ value, $V_{DD}=12 \text{ V}, \Delta B_{speed} \geq 4 \text{ mT}$ peak to peak

3.3 ESD Robustness

Table 3-3 ESD Protection

Parameter	Symbol	Test	Unit	Note
ESD-Protection	V_{ESD}	± 12	kV	$R = 1.5 \text{ k}\Omega, C = 100 \text{ pF}$

3.4 Timing Characteristics

Between each magnetic transition and the rising edge of the corresponding output pulse, the output current is low for $t_{pre-low}$ in order to allow reliable internal conveyance. After pre low time the output current level is set to high.

After power on the speed pulse is being issued. As soon as the sensor has enough information to recognize the direction of the target wheel, the output pulse will include the direction information.

Rotation direction is evaluated only for low rotation speed. The speed signal will be delivered again if the magnetic frequency is above $f_{DR,max}$.

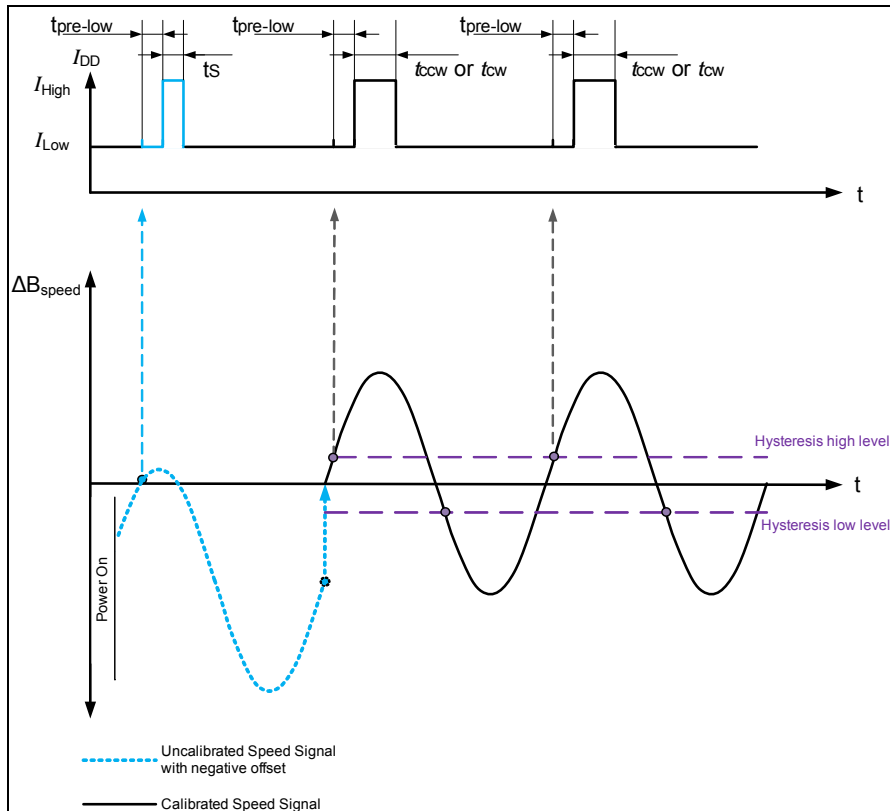

Figure 3-1 Definition of PWM Current Interface - TLE4954C, TLE4954C-E2, TLE4954C-E4

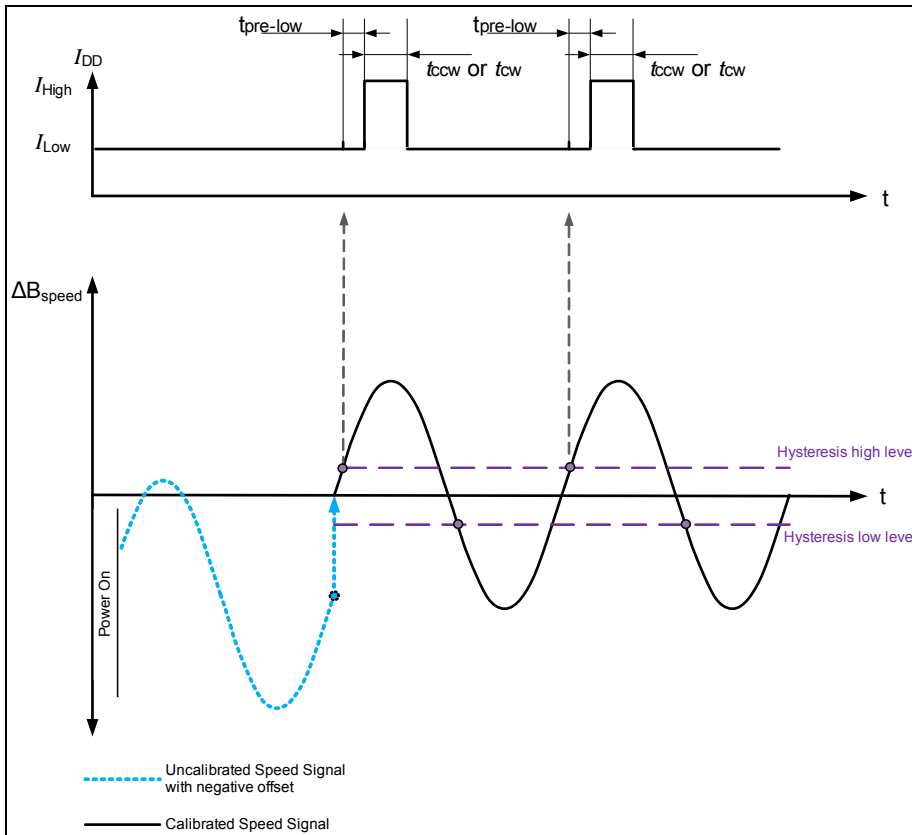

Figure 3-2 Definition of PWM Current Interface - TLE4954C-E1

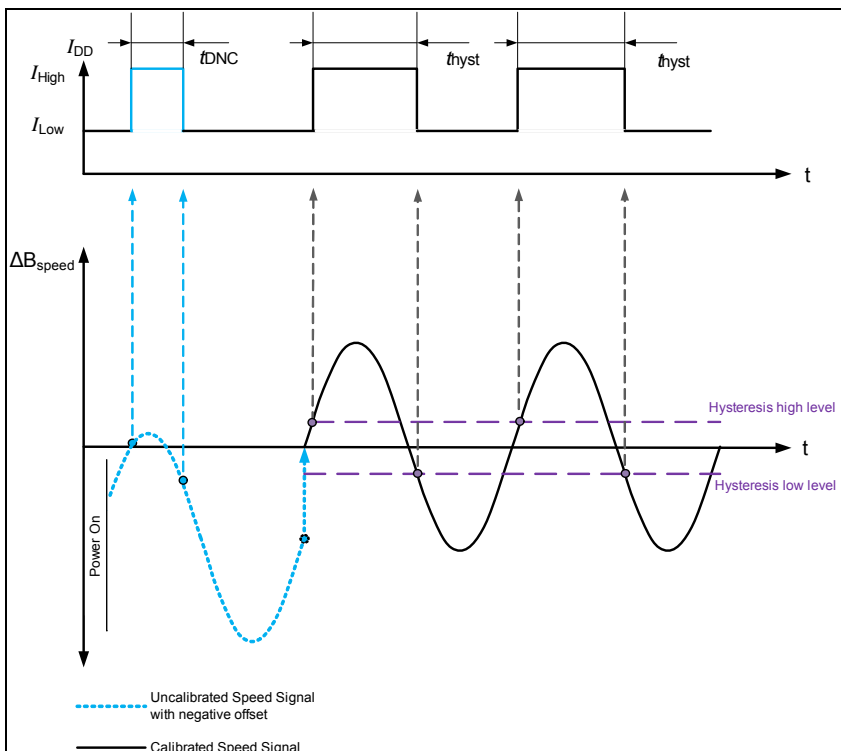

Figure 3-3 Definition of Current interface - TLE4951C

3.5 Operation characteristics - TLE4951CB, TLE4954CB, TLE4954CB-E1, TLE4954CB-E2

Table 3-4 TLE4954CB, TLE4951CB

Parameter	Symbol	Values			Unit	Remarks
		min	typ	max		
Operational airgap	AG		3.3		mm	Valid in running mode, measured from sensor housing (branded side) to target tooth. Valid at 25°C & 0h. No missing output pulses.
Minimum speed signal	$\Delta B_{\text{speed-limit}}$		2.2		mT	Peak to peak value 99% criteria
Minimum direction signal	$\Delta B_{\text{Bdir-limit}}$		0.36		mT	Peak to peak value 99% criteria

Table 3-5 TLE4954CB-E1, TLE4954CB-E2

Parameter	Symbol	Values			Unit	Remarks
		min	typ	max		
Operational airgap	AG		-		mm	Valid in running mode, measured from sensor housing (branded side) to target tooth. Valid at 25°C & 0h. No missing output pulses.
Minimum speed signal	$\Delta B_{\text{speed-limit}}$		2.2		mT	Peak to peak value 99% criteria
Minimum direction signal	$\Delta B_{\text{Bdir-limit}}$		0.9		mT	Peak to peak value 99% criteria

3.6 Reference Target Wheel for TLE4951CB, TLE4954CB, TLE4954CB-E1, TLE4954CB-E2

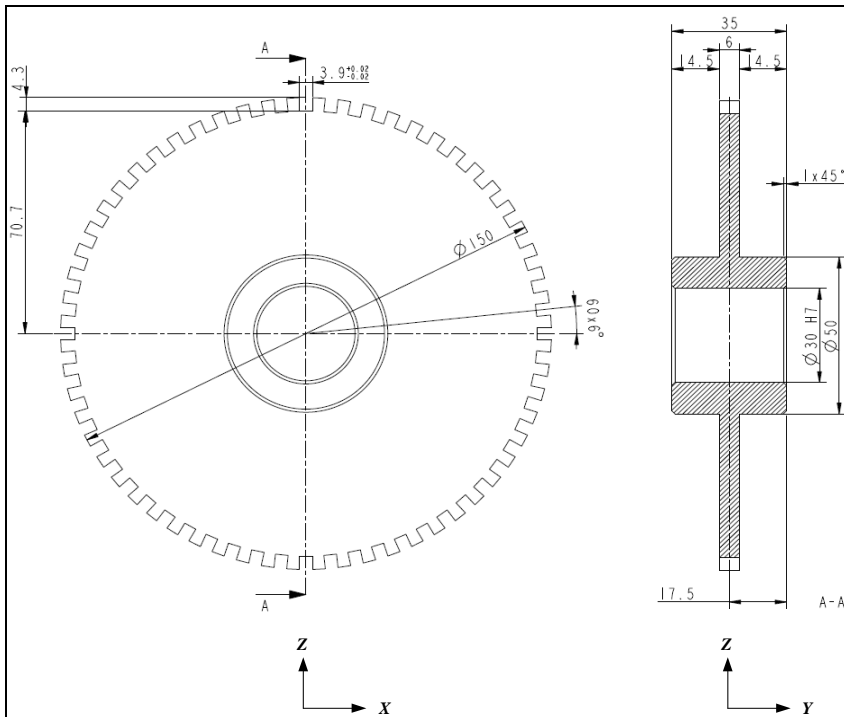

Figure 3-4 Reference target wheel

Table 3-6 Reference target wheel geometry

Parameter	Symbol	Typ value	Unit	Remarks
Outside diameter	d	150	mm	
Number of teeth	Z	60	-	
Pitch Ratio		50:50	%	
Material		ST37		

4 Package Information

4.1 Package Information TLE4954C, TLE4954C-E1, TLE4954C-E2, TLE4951C

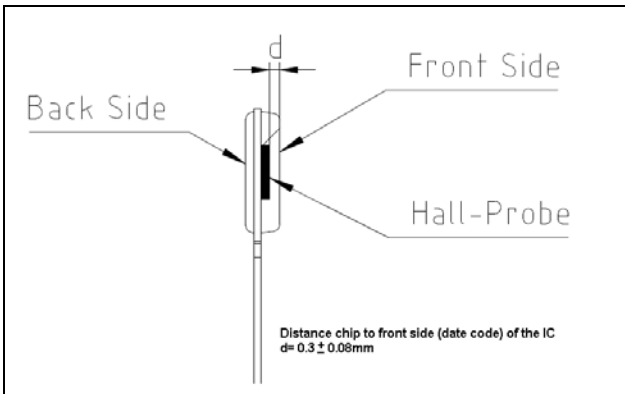

Figure 4-1 Distance of the chip to the upper package edge

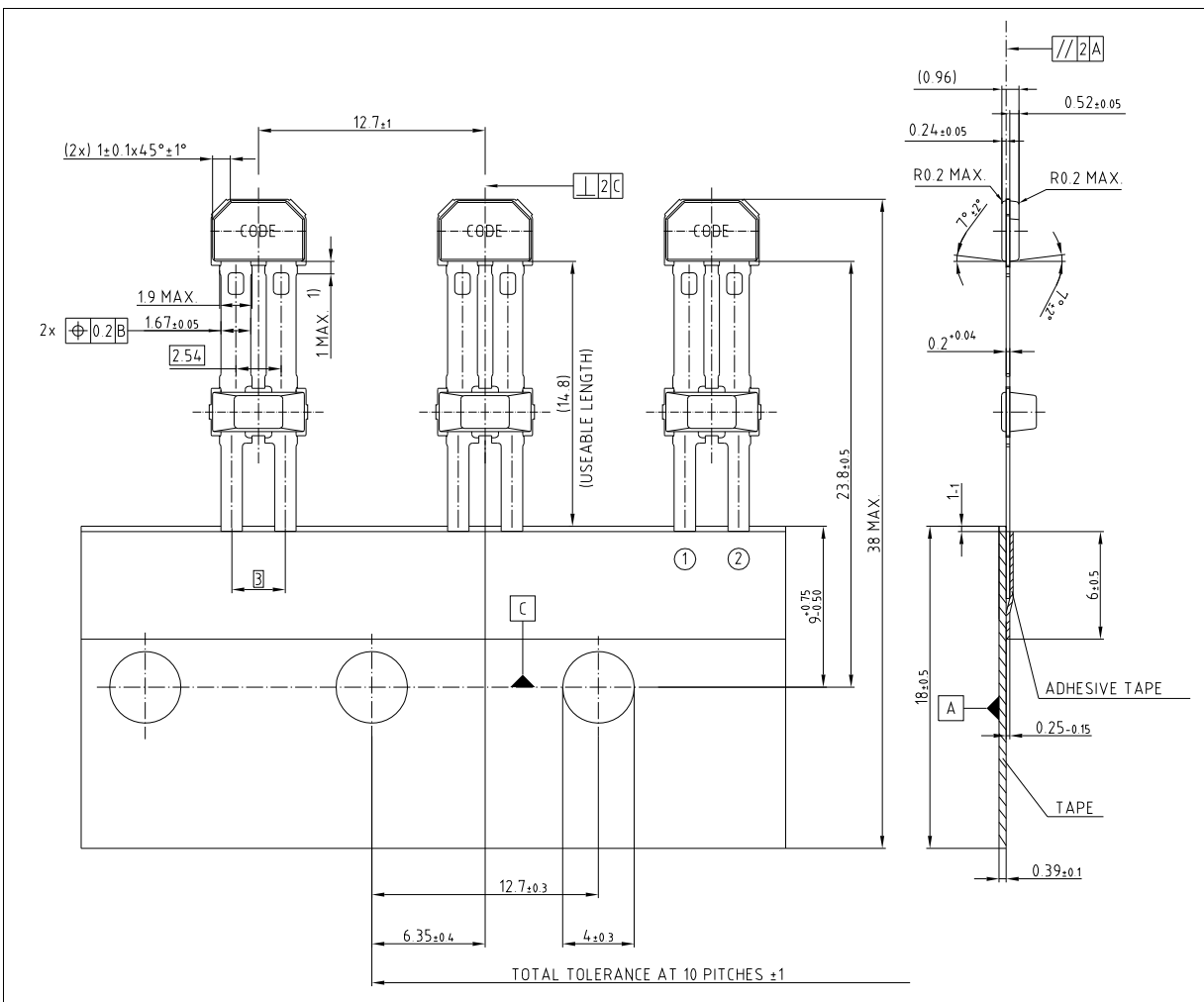
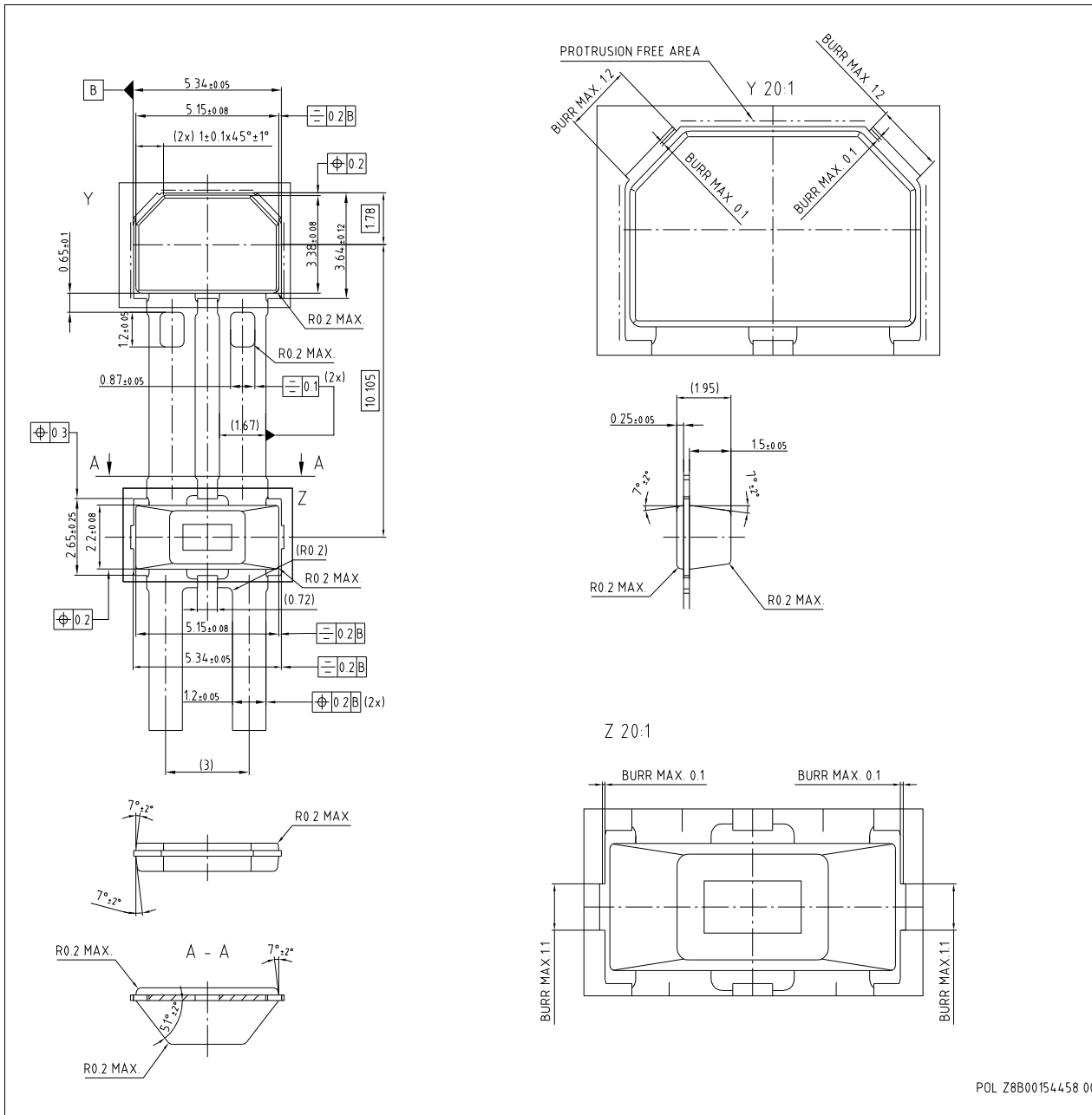

Figure 4-2 PG-SSO-2-53 (Plastic Single Small Outline Package) packing, all dimensions in mm



4.2 Package Information TLE4951CB, TLE4954CB, TLE4954CB-E1, TLE4954CB-E2

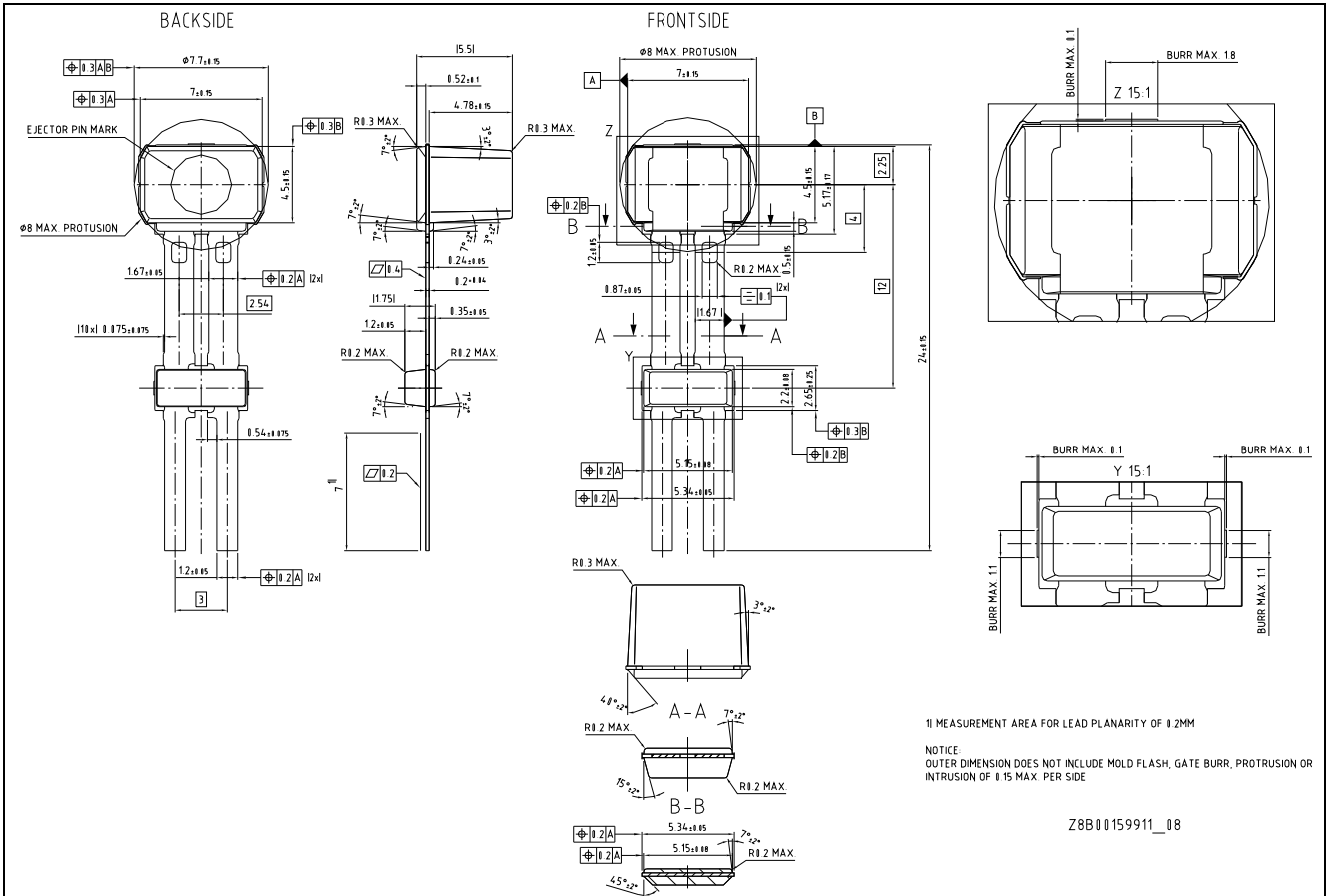

Figure 4-4 PG-SSOM-2-11 package outline

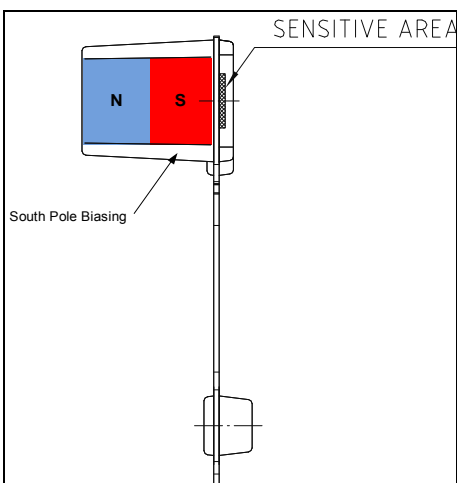

Figure 4-5 Back-bias field orientation

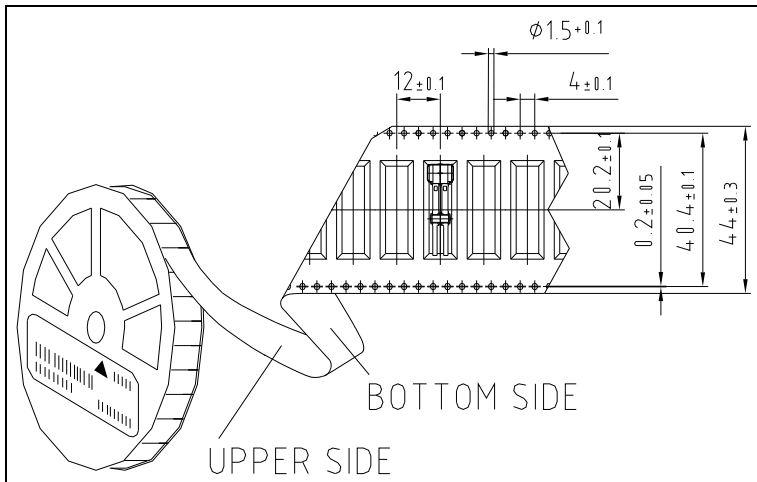

Figure 4-6 PG-SSOM-2-11 blister tape packing information

For additional and more detailed information about the chip and package please visit the Infineon web page <http://www.infineon.com>.

Edition 2013-10-15

Published by
Infineon Technologies AG
81726 Munich, Germany

© 2014 Infineon Technologies AG
All Rights Reserved.

Legal Disclaimer

The information given in this document shall in no event be regarded as a guarantee of conditions or characteristics. With respect to any examples or hints given herein, any typical values stated herein and/or any information regarding the application of the device, Infineon Technologies hereby disclaims any and all warranties and liabilities of any kind, including without limitation, warranties of non-infringement of intellectual property rights of any third party.

Information

For further information on technology, delivery terms and conditions and prices, please contact the nearest Infineon Technologies Office (www.infineon.com).

Warnings

Due to technical requirements, components may contain dangerous substances. For information on the types in question, please contact the nearest Infineon Technologies Office. Infineon Technologies components may be used in life-support devices or systems only with the express written approval of Infineon Technologies, if a failure of such components can reasonably be expected to cause the failure of that life-support device or system or to affect the safety or effectiveness of that device or system. Life support devices or systems are intended to be implanted in the human body or to support and/or maintain and sustain and/or protect human life. If they fail, it is reasonable to assume that the health of the user or other persons may be endangered.

www.infineon.com

Published by Infineon Technologies AG

Looking for pricing, stock, or lifecycle information?

Click below to explore more details on WIN SOURCE:

- ⊖ [View TLE4954CE4807BAMA1 on WIN SOURCE](#)
- ⊖ [Infineon Technologies Information](#)

Optimize Your Supply Chain with WIN SOURCE Solutions

- ✓ Global Sourcing Solution
- ✓ Obsolete Management
- ✓ Cost Control Management
- ✓ Shortage Management
- ✓ Alternative Solution
- ✓ Excess Inventory Management