

COMP-O-GIDE™**Industry Standard Snap-in Card Guides for 1/16th PCBs**

- 52 configurations to meet most standard requirements
- Precision Molded for rigidity, strength and heat resistance from 94V-2 UL rated materials
- Stainless Steel Conductive Inserts available for all sizes (see page 19)
- Two channel depths and two channel widths available to accommodate 1/16th & 3/32nd PCBs
- Common industry standards interchange with competitive devices

COMP-O-GIDE, was introduced in 1985 to provide second sources for previously single source card guides. The series has expanded to offer wider selection and application specific function. Rigid, strong and economical, COMP-O-GIDES provide the installed reliability that your most demanding products require. Retention is firm and there are no special tools or fixtures required for installation.

Mounting Information:

Snap-in metal plates: 0.047" - 0.090" (1.2mm - 2.3mm) thick
Hole Size: 0.180" (4.6mm) diameter + 0.003 (0.08mm), - 0.001 (0.03mm) 3/16th drill

Material Specifications:

UL Rated 94V-2, natural, 6/6 Nylon per ASTM D4066 PA111
Oxygen Index: +28%
UL File #E135532

Application Notes:

Slotting or elongating of the second and third mounting hole is recommended to allow for length variations and to provide for easier assembly.

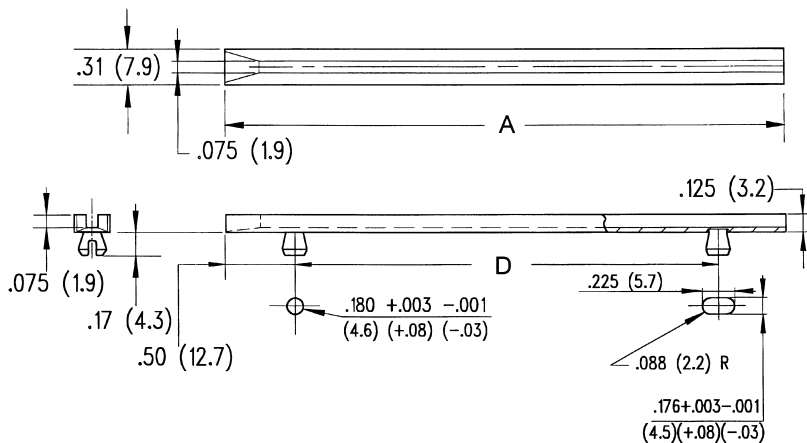
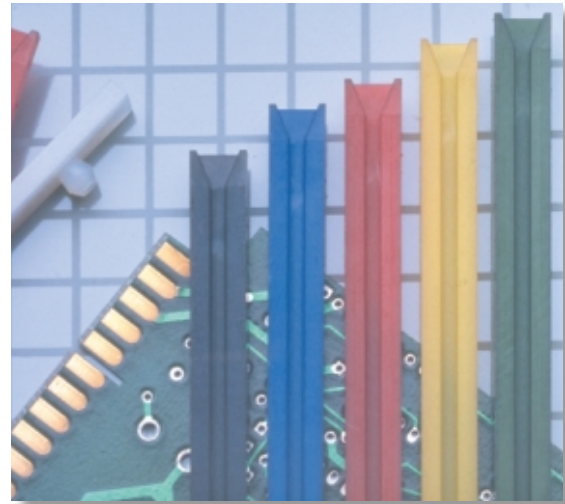

Prolonged pre-assembly exposure to high humidity can cause molded Nylon components to "grow" out of tolerance. Storage in a cool dry place is recommended. Open sealed vapor barrier bags at the time of production to assure optimum shelf life.

**Comp-O-Gide for 1/16th PCBs
2 1/2" thru 8" Lengths**

Part No.	A ±.031 (.79)	B ±.016 (.41)
SFS-250	2.5 (63.5)	1.5 (38.1)
SFS-300	3.0 (76.2)	2.0 (50.8)
SFS-350	3.5 (88.9)	2.5 (63.5)
SFS-400	4.0 (101.6)	3.0 (76.2)
SFS-450	4.5 (114.3)	3.0 (76.2)
SFS-451	4.5 (114.3)	3.5 (88.9)
SFS-500	5.0 (127.0)	4.0 (101.6)
SFS-550	5.5 (139.7)	4.5 (114.3)
SFS-600	6.0 (152.4)	5.0 (127.0)
SFS-650	6.5 (165.1)	5.02 (127.5)
SFS-651	6.5 (165.1)	5.5 (139.7)
SFS-700	7.0 (177.8)	6.0 (152.4)
SFS-750	7.5 (190.5)	6.5 (165.1)
SFS-800	8.0 (203.2)	7.0 (177.8)

Looking for pricing, stock, or lifecycle information?

Click below to explore more details on WIN SOURCE:

-  [View SFS-800 on WIN SOURCE](#)
-  [Bivar Inc. Information](#)

Optimize Your Supply Chain with WIN SOURCE Solutions

-  Global Sourcing Solution
-  Obsolete Management
-  Cost Control Management
-  Shortage Management
-  Alternative Solution
-  Excess Inventory Management