

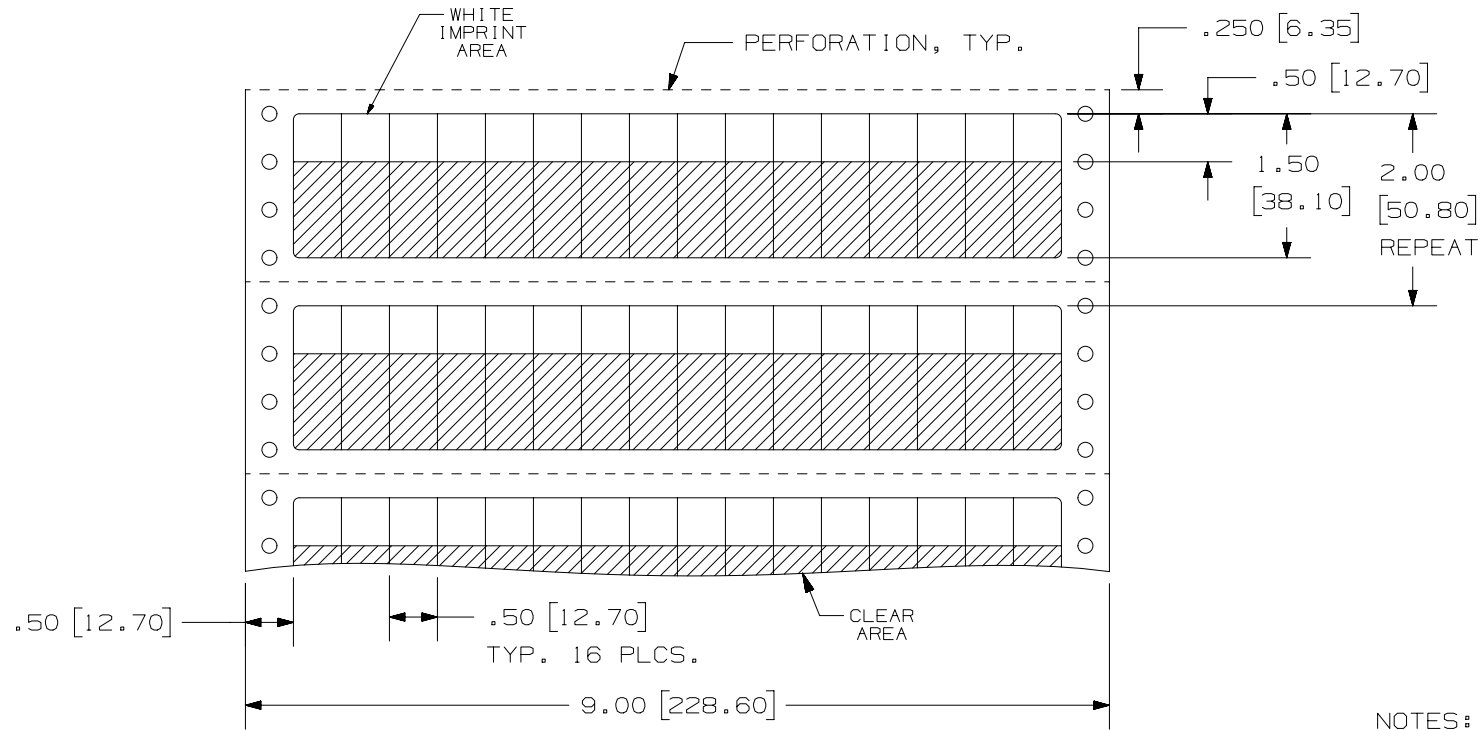

**THE DATASHEET OF
S050X150TAD-A**



THIS COPY IS PROVIDED ON A RESTRICTED BASIS AND IS NOT TO BE USED IN ANY WAY DETRIMENTAL TO THE INTERESTS OF PANDUIT CORP.



- NOTES:
 1. ALL LABELS TO BE EQUALLY SPACED AS SHOWN.
 2. MILLIMETERS ARE IN [].

PART NUMBER	MATERIAL	MARKER SIZE inches [mm]	ROWS PER FANFOLD	LABELS PER ROW	STANDARD PKG. QTY.
S050X150T1D	GMTD1	.500" [12.7] X X	6	16	5000
S050X150TAD-A	GMT1	1.50" [38.1]			

TITLE S050X150T1D AND S050X150TAD-A PVDF & Tedlar SELF-LAMINATING DOT MATRIX PRINTABLE LABEL CUSTOMER DRAWING	
ITEM REVISION NAME 100619RU/01	PANDUIT
DATASET FILE NAME 100619RU-DC-C10855/00A	
UNLESS OTHERWISE SPECIFIED, DIMENSIONAL TOLERANCES ARE: IN [mm] .x ± .12 [3.05] .xxx ± .025 [.635] .xx ± .062 [1.57] ANGLES ±	
THIRD ANGLE PROJECTION	
DRAWING NUMBER: C10855	
DRAWN BY RVU	DATE 10/4/10
CHK MSAD	SCALE NTS
SHT 1 OF 1	
SIZE A	

REV	DATE	BY	CHK	APR	DESCRIPTION	ECN
1	8/31/17	RVU	JW	JHAC	ADD NEW PN, S050X150TAD-A TO TABLE.	GAECN04272
0	10/4/10	RVU	SEWH	MSAD	RELEASE TO PRODUCTION.	6160

D10100DA/20

2

1

2

1

Looking for pricing, stock, or lifecycle information?

Click below to explore more details on WIN SOURCE:

 [View S050X150TAD-A on WIN SOURCE](#)

 [Panduit Corp](#) Information

Optimize Your Supply Chain with WIN SOURCE Solutions

-  Global Sourcing Solution
-  Obsolete Management
-  Cost Control Management
-  Shortage Management
-  Alternative Solution
-  Excess Inventory Management