

SZNS6A5.0AFT3G Series

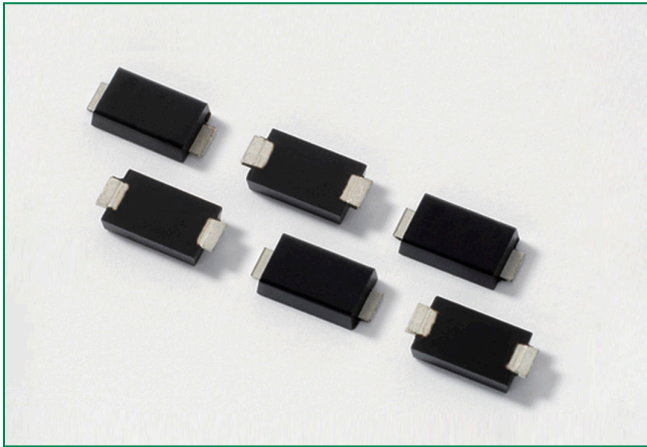

Maximum Ratings and Thermal Characteristics

Rating	Symbol	Value	Unit
Peak Power Dissipation (Note 1) @ $T_L = 25^\circ\text{C}$, Pulse Width = 1 ms	P_{PK}	500	W
DC Power Dissipation (Note 3) @ $T_A = 75^\circ\text{C}$	P_D	1.5	W
Derate Above 75°C		20	mW/ $^\circ\text{C}$
Thermal Resistance from Junction-to-Ambient	$R_{\theta JL}$	50	$^\circ\text{C}/\text{W}$
DC Power Dissipation (Note 3) @ $T_A = 25^\circ\text{C}$ Derate Above 25°C	P_D	0.5	W
Thermal Resistance from Junction-to-Ambient	$R_{\theta JA}$	4.0	mW/ $^\circ\text{C}$
Forward Surge Current (Note 4) @ $T_A = 25^\circ\text{C}$	I_{FSM}	40	A
Operating and Storage Temperature Range	T_J, T_{stg}	-65 to +150	$^\circ\text{C}$

Notes:

- 10 X 1000 μs , non-repetitive.
- 1 in square copper pad, FR-4 board.
- FR-4 board, using Littelfuse minimum recommended footprint, as shown in 403AA case outline dimensions spec.
- 1/2 sine wave (or equivalent square wave), PW = 8.3 ms, duty cycle = 4 pulses per minute maximum

Description

The SZNS6AxxAFT3G series is designed to protect voltage sensitive components from high voltage, high energy transients. This device has excellent clamping capability, high surge capability, low zener impedance and fast response time. The SZNS6AxxAFT3G series is ideally suited for use in computer hard disk drives, communication systems, automotive, numerical controls, process controls, medical equipment, business machines, power supplies and many other industrial/consumer applications.

Features

- Peak Reverse Working Voltage Range – 5 V to 64 V
- Peak Pulse Power of 500 W (10 x 1000 sec)
- ESD Rating of Class 3 (>16 kV) per Human Body Model
- ESD Rating of Class 4 (>8 kV) IEC 61000-4-2
- Fast Response Time
- Low Profile Package
- These Devices are Pb-Free and are RoHS Compliant
- SZ Prefix for Automotive and Other Applications Requiring Unique Site and Control Change Requirements; AEC-Q101 Qualified and PPAP Capable

Functional Diagram

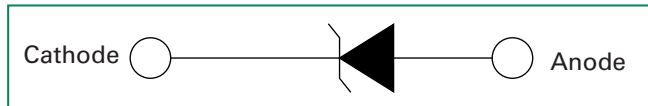

Additional Information



Datasheet



Resources



Samples

I-V Curve Characteristics ($T_A = 25^\circ\text{C}$ unless otherwise noted, $V_F = 3.5\text{V Max.}$ @ I_F (Note 5) = 30 A)

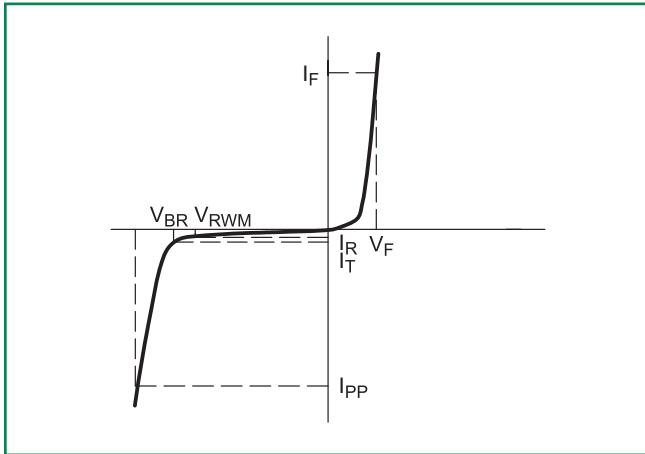

Symbol	Parameter
I_{PP}	Maximum Reverse Peak Pulse Current
V_C	Clamping Voltage @ I_{PP}
V_{RWM}	Working Peak Reverse Voltage
I_R	Maximum Reverse Leakage Current @ V_{RWM}
V_{BR}	Breakdown Voltage @ I_T
I_T	Test Current
I_T	Forward Current
I_F	Forward Voltage
V_F	Forward Voltage @ I_F

5. 1/2 sine wave (or equivalent square wave), PW = 8.3 ms, non-repetitive duty cycle.

Ratings and Characteristic Curves

Figure 1. 10 x 1000 μs Pulse Waveform

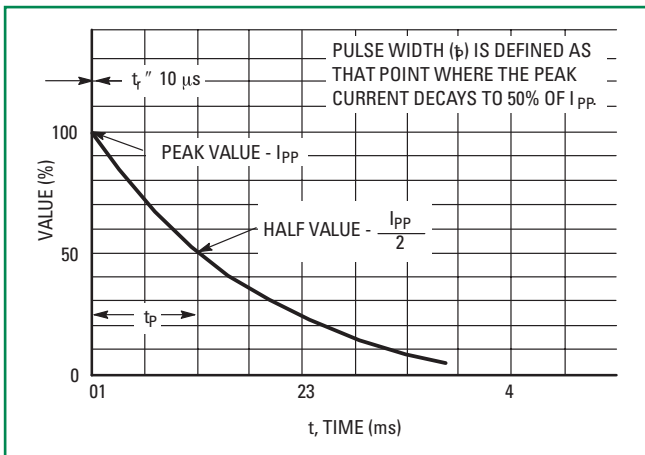

Figure 2. Pulse Derating Curve

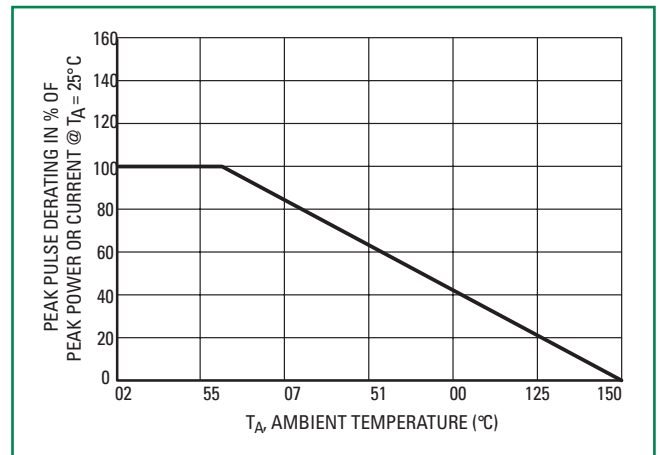
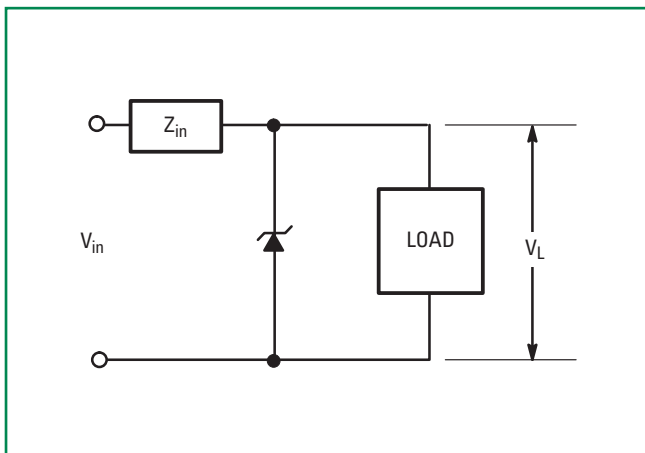

Figure 3. Typical Protection Circuit



Electrical Characteristics ($T_A=25^\circ\text{C}$ unless otherwise noted, $V_F = 3.5\text{ V Max.}$ @ I_F (Note 6) = 50 A)

Device *	Device Marking	V_{RWM} (Note 6)	I_R @ V_{RWM}	Breakdown Voltage				V_C @ I_{PP} (Note 8)		C _{typ} (Note 9)
				V_{BR} (Note 7) (V)			@ I_T	V_C	I_{PP}	
				MIN	NOM	MAX				mA
SZNS6A5.0AFT3G	6AA	5	800	6.4	6.70	7	10	9.2	65.2	2700
SZNS6A6.0AFT3G**	6AB	6	800	6.67	7.02	7.37	10	10.3	58.3	2300
SZNS6A6.5AFT3G**	6AC	6.5	500	7.22	7.60	7.98	10	11.2	53.6	2140
SZNS6A7.0AFT3G**	6AD	7	500	7.78	8.19	8.6	10	12	50	2005
SZNS6A7.5AFT3G**	6AE	7.5	100	8.33	8.77	9.21	1	12.9	46.5	1890
SZNS6A8.0AFT3G**	6AF	8	50	8.89	9.36	9.83	1	13.6	44.1	1780
SZNS6A8.5AFT3G	6AG	8.5	10	9.44	9.92	10.4	1	14.4	41.7	1690
SZNS6A9.0AFT3G**	6AH	9	5	10	10.55	11.1	1	15.4	39	1605
SZNS6A10AFT3G**	6AI	10	5	11.1	11.70	12.3	1	17	35.3	1460
SZNS6A11AFT3G**	6AL	11	5	12.2	12.85	13.5	1	18.2	33	1345
SZNS6A12AFT3G	6AJ	12	5	13.3	14.00	14.7	1	19.9	30.2	1245
SZNS6A13AFT3G	6AK	13	5	14.4	15.15	15.9	1	21.5	27.9	1160
SZNS6A14AFT3G**	6AM	14	5	15.6	16.40	17.2	1	23.2	20.5	1085
SZNS6A15AFT3G	6AN	15	5	16.7	17.60	18.5	1	24.4	20.0	1020
SZNS6A16AFT3G**	6AO	16	5	17.8	18.75	19.7	1	26	19.5	965
SZNS6A17AFT3G**	6AP	17	5	18.9	19.90	20.9	1	27.6	19.0	915
SZNS6A18AFT3G**	6AQ	18	5	20	21.05	22.1	1	29.2	18.5	870
SZNS6A20AFT3G**	6AR	20	5	22.2	23.35	24.5	1	32.4	17.5	790
SZNS6A22AFT3G	6AS	22	5	24.4	25.65	26.9	1	35.5	16.5	730
SZNS6A24AFT3G	6AT	24	5	26.7	28.10	29.5	1	38.9	15.4	675
SZNS6A26AFT3G**	6AU	26	5	28.9	30.40	31.9	1	42.1	14.2	630
SZNS6A28AFT3G	6AV	28	5	31.1	32.75	34.4	1	45.4	13.2	590
SZNS6A30AFT3G	6AW	30	5	33.3	35.05	36.8	1	48.4	12.4	555
SZNS6A33AFT3G	6AX	33	5	36.7	38.65	40.6	1	53.3	11.3	510
SZNS6A36AFT3G	6AY	36	5	40	42.10	44.2	1	58.1	10.3	470
SZNS6A40AFT3G**	6AZ	40	5	44.4	46.75	49.1	1	64.5	9.3	430
SZNS6A43AFT3G**	6A0	43	5	47.8	50.30	52.8	1	69.4	8.6	400
SZNS6A45AFT3G**	6A1	45	5	50	52.65	55.3	1	72.2	8.3	385
SZNS6A48AFT3G**	6A2	48	5	53.3	56.10	58.9	1	77.4	7.7	365
SZNS6A51AFT3G**	6A3	51	5	56.7	59.70	62.7	1	82.4	7.3	345
SZNS6A54AFT3G**	6A4	54	5	60	63.15	66.3	1	87.1	6.9	330
SZNS6A58AFT3G**	6A5	58	5	64.4	67.80	71.2	1	93.6	6.4	310
SZNS6A60AFT3G**	6A7	60	5	66.7	70.20	73.7	1	96.8	6.2	300
SZNS6A64AFT3G	6A8	64	5	71.1	74.85	78.6	1	103	5.8	280

Notes:

**In development. Contact local sales rep for availability.

6. A transient suppressor is normally selected according to the working peak reverse voltage (VRWM), which should be equal to or greater than the DC or continuous peak operating voltage level.

7. VBR measured at pulse test current IT at an ambient temperature of 25°C.

8. Surge current waveform per Figure 1.

9. Bias Voltage = 0 V, F = 1 MHz, Tj = 25°C.

Dimensions

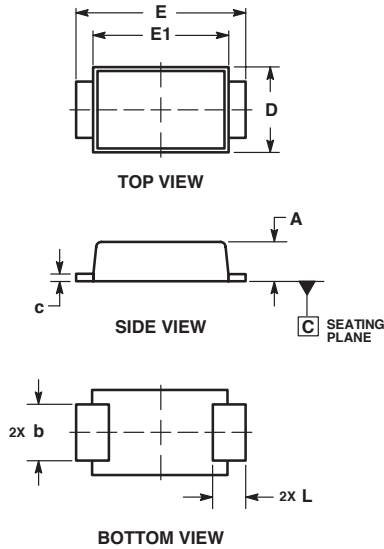

Dim	Millimeters	
	Min	Max
A	0.90	1.10
b	1.25	1.65
c	0.15	0.30
D	2.40	2.80
E	4.80	5.40
E1	4.00	4.60
L	0.70	1.10

- NOTES:
1. DIMENSIONING AND TOLERANCING PER ASME Y14.5M, 1994.
2. CONTROLLING DIMENSION: MILLIMETERS.

Part Marking System



- xxx = Specific Device Code
- A = Assembly Location
- Y = Year
- WW = Work Week
- = Pb-Free Package

Soldering Footprint

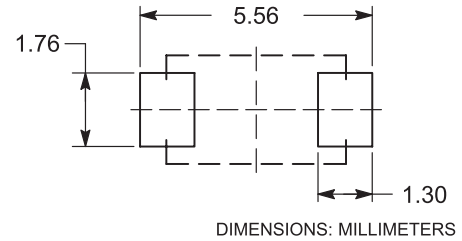

DIMENSIONS: MILLIMETERS

ORDERING INFORMATION

Device	Package	Shipping†
SZNS6AxxAFT3G	SMA-FL (Pb-Free)	5000 / Tape & Reel

Flow/Wave Soldering (Solder Dipping)

Peak Temperature :	260°C
Dipping Time :	10 seconds

Physical Specifications

Case	Void-free, transfer-molded, thermosetting plastic
Polarity	Cathode indicated by polarity band
Leads	Modified L-Bend providing more contact area to bond pads
Finish	All external surfaces are corrosion resistant and leads are readily solderable

Disclaimer Notice - Information furnished is believed to be accurate and reliable. However, users should independently evaluate the suitability of and test each product selected for their own applications. Littelfuse products are not designed for, and may not be used in, all applications. Read complete Disclaimer Notice at: www.littelfuse.com/disclaimer-electronics.

Looking for pricing, stock, or lifecycle information?

Click below to explore more details on WIN SOURCE:

 [View SZNS6A13AFT3G on WIN SOURCE](#)

 [Littelfuse Inc. Information](#)

Optimize Your Supply Chain with WIN SOURCE Solutions

-  Global Sourcing Solution
-  Obsolete Management
-  Cost Control Management
-  Shortage Management
-  Alternative Solution
-  Excess Inventory Management