



# THE DATASHEET OF SCRU-01



DO NOT SCALE FROM THIS PRINT

DESIGNED & DIMENSIONED IN MILLIMETERS [INCHES]

SCRU-XX

STYLE  
 -01: USE SCRUA-S-01 (SEE FIG. 1, SHT 1)  
 -02: USE SCRUA-S-02 (SEE FIG. 2, SHT 2)

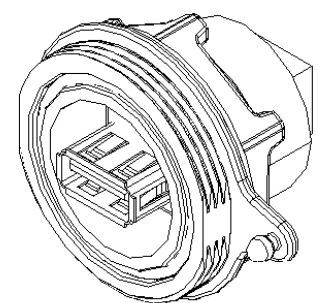
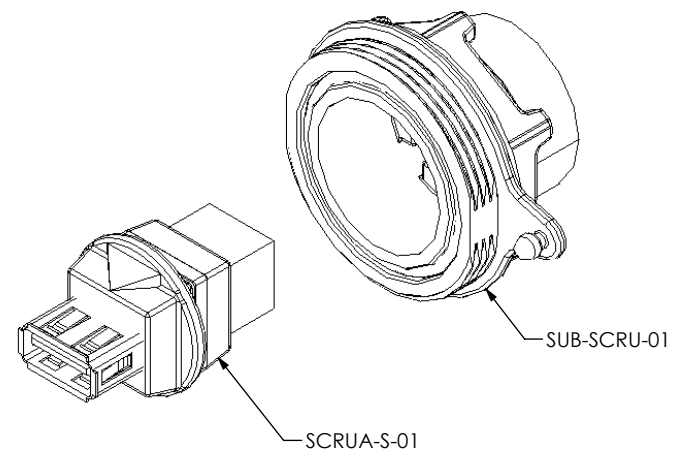
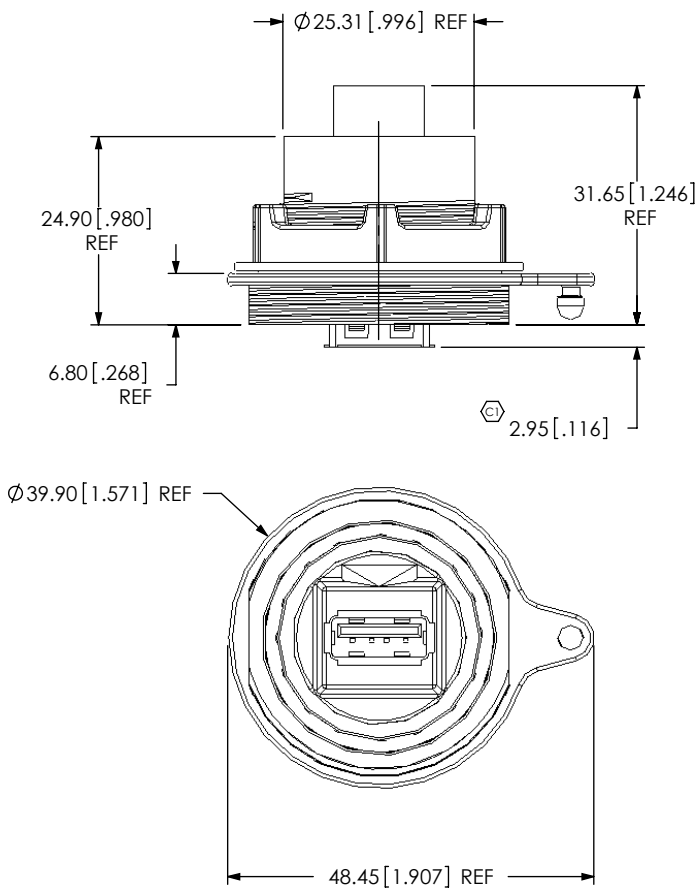

RECOMMENDED PANEL HOLE FOR -01 & -02 STYLES (SEE NOTE 3)

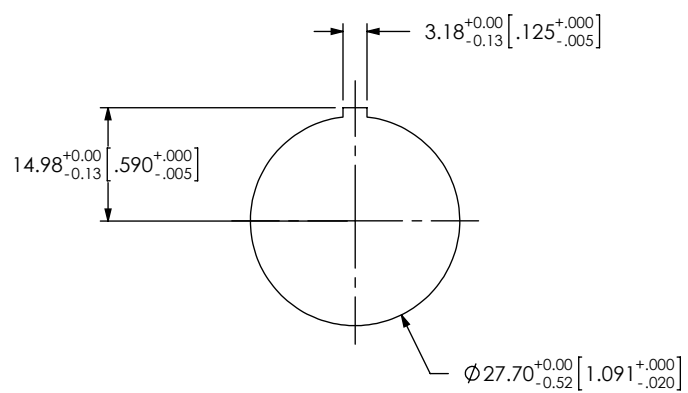



FIG. 1 (SCRU-01 SHOWN)

- NOTES:
1. Ⓢ REPRESENTS A CRITICAL DIMENSION.
  2. ASSEMBLY TO MEET UL 94V-0.
  3. PANEL THICKNESS: 0.8[.03] - 5.2[.205].
  4. PARTS TO BE PACKAGED IN TRAYS.

F:\DWG\MISC\MKTG\SCRU-XX-MKT.SLDRW

|  |   |   |
|--|---|---|
| <p>UNLESS OTHERWISE SPECIFIED, DIMENSIONS ARE IN MILLIMETERS. TOLERANCES ARE:</p> <p>DECIMALS ANGLES</p> <p>.X: ±0.3 [.01] 2°</p> <p>.XX: ±0.13 [.005]</p> <p>.XXX: ±0.051 [.0020]</p>   | <p>PROPRIETARY NOTE</p> <p>THIS DOCUMENT CONTAINS INFORMATION CONFIDENTIAL AND PROPRIETARY TO SAMTEC, INC. AND SHALL NOT BE REPRODUCED OR TRANSFERRED TO OTHER DOCUMENTS OR DISCLOSED TO OTHERS OR USED FOR ANY PURPOSE OTHER THAN THAT WHICH IT WAS OBTAINED WITHOUT THE EXPRESSED WRITTEN CONSENT OF SAMTEC, INC.</p> |  <p>520 PARK EAST BLVD, NEW ALBANY, IN 47150<br/>             PHONE: 812-944-6733 FAX: 812-948-5047<br/>             e-Mail info@SAMTEC.com code 55322</p> |
| <p>MATERIAL: OR-17-01: SILICONE DO NOT SCALE DRAWING SHEET SCALE: 1:1<br/>             PMB-17-01: PA66<br/>             SPG-17-01: SILICONE<br/>             SPN-17-01: PA66<br/>             SCRUA-XX INSULATOR: PBT<br/>             SCRUA-XX CONTACTS: PHOS BRONZE<br/>             SCRUA-XX SHIELDS: PHOS BRONZE<br/>             SCRUA-XX OVERMOLD: PBT</p> |   | <p>DESCRIPTION:<br/>                 USB PANEL MOUNT ASSEMBLY</p> <p>DWG. NO.<br/>                 SCRU-XX</p> <p>BY: CHAD F 12/13/2004 SHEET 1 OF 2</p>  |

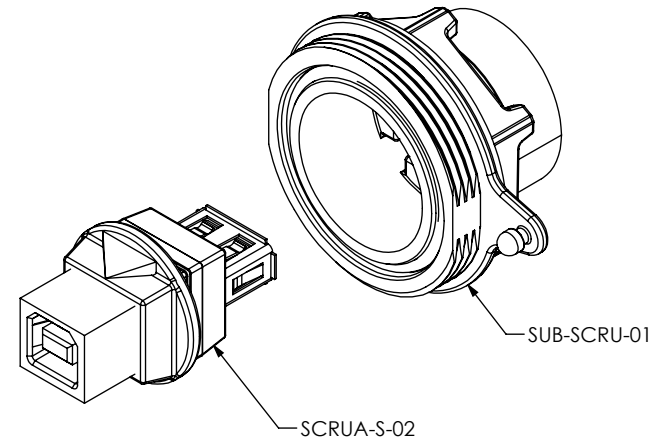
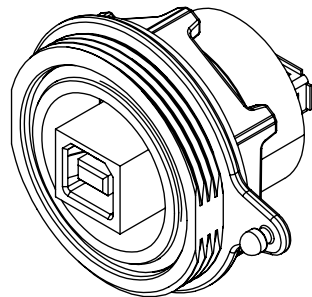
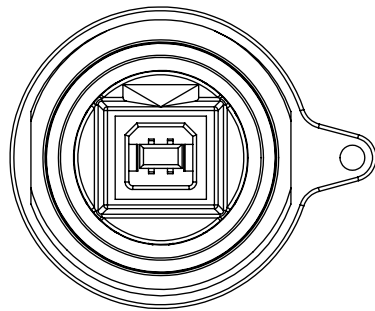
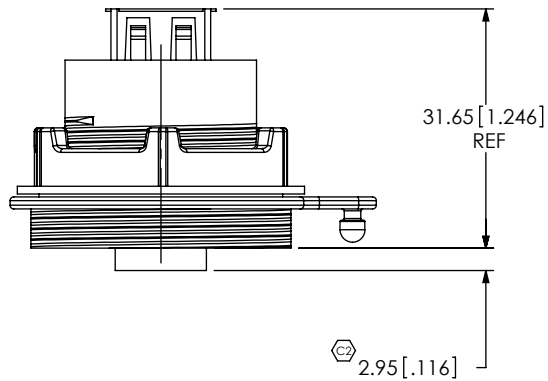

FIG. 2  
(SCRU-02 SHOWN)  
(SAME AS FIG. 1, UNLESS OTHERWISE STATED)

**PROPRIETARY NOTE**  
THIS DOCUMENT CONTAINS INFORMATION CONFIDENTIAL AND PROPRIETARY TO SAMTEC, INC. AND SHALL NOT BE REPRODUCED OR TRANSFERRED TO OTHER DOCUMENTS OR DISCLOSED TO OTHERS OR USED FOR ANY PURPOSE OTHER THAN THAT WHICH IT WAS OBTAINED WITHOUT THE EXPRESSED WRITTEN CONSENT OF SAMTEC, INC.

DO NOT SCALE DRAWING

SHEET SCALE: 1:1

**samtec**

520 PARK EAST BLVD, NEW ALBANY, IN 47150  
PHONE: 812-944-6733 FAX: 812-948-5047  
e-Mail info@SAMTEC.com code 55322

DESCRIPTION: USB PANEL MOUNT ASSEMBLY

DWG. NO. SCRU-XX

BY: CHAD F 12/13/2004 SHEET 2 OF 2

## Looking for pricing, stock, or lifecycle information?

Click below to explore more details on WIN SOURCE:

 [View SCRU-01 on WIN SOURCE](#)

 [Samtec Inc. Information](#)

## Optimize Your Supply Chain with WIN SOURCE Solutions

-  Global Sourcing Solution
-  Obsolete Management
-  Cost Control Management
-  Shortage Management
-  Alternative Solution
-  Excess Inventory Management