



**THE DATASHEET OF
S5U13U11P00C100**



S1D13U11

S1D13U11 SVGA USB Interface LCD Controller

The S1D13U11 is a SVGA USB interface LCD controller with an external SDRAM interface. The external SDRAM interface allows for support of a variety of memory sizes for the display buffer.

The S1D13U11 supports a USB2.0 High-speed device port interface and provides high performance bandwidth to external SDRAM, allowing for fast screen updates. Supporting TFT panels up to a SVGA resolutions (800x600), it can output either 24 bpp (RGB888) or 16 bpp (RGB565). The design also includes display features such as Picture-in-Picture, Double-Buffering, Alpha Blending, and Mirror/Rotation functions.

Additionally the S1D13U11 supports one I2C and two SPI serial interfaces allowing it to be connected to an external touch screen controller and serial flash ROM. The S1D13U11 is an ideal choice for a wide variety of application requiring an LCD controller to connect between a host CPU and LCD panel via the USB port.

FEATURES

- High performance SDRAM controller
- External 16/64/128M-bit SDRAM memory support
- USB 2.0 High-speed device port (480Mbps)
- Embedded USB protocol sequencer
- Input data formats:
 - RGB 8:8:8
 - RGB 5:6:5
- Supports TFT panels:
 - 16/18/24-bit interfaces
- Resolutions up to 800x600 @ 24 bpp
- I2C master and two SPI master interfaces
- Main and two Picture-in-Picture windows
- Multi-buffer display or Double-buffer display
- Alpha Blending
- Mirror / Rotation functions
- Display Enhancement features
- PWM output for LED backlight control
- Internal 12M/24M oscillator and PLL
- 8x8 Hardware Key scan interface
- Power:
 - USB and IO 3.3 volts
 - CORE and PLL 1.8 volts
- QFP20-144

SYSTEM BLOCK DIAGRAM

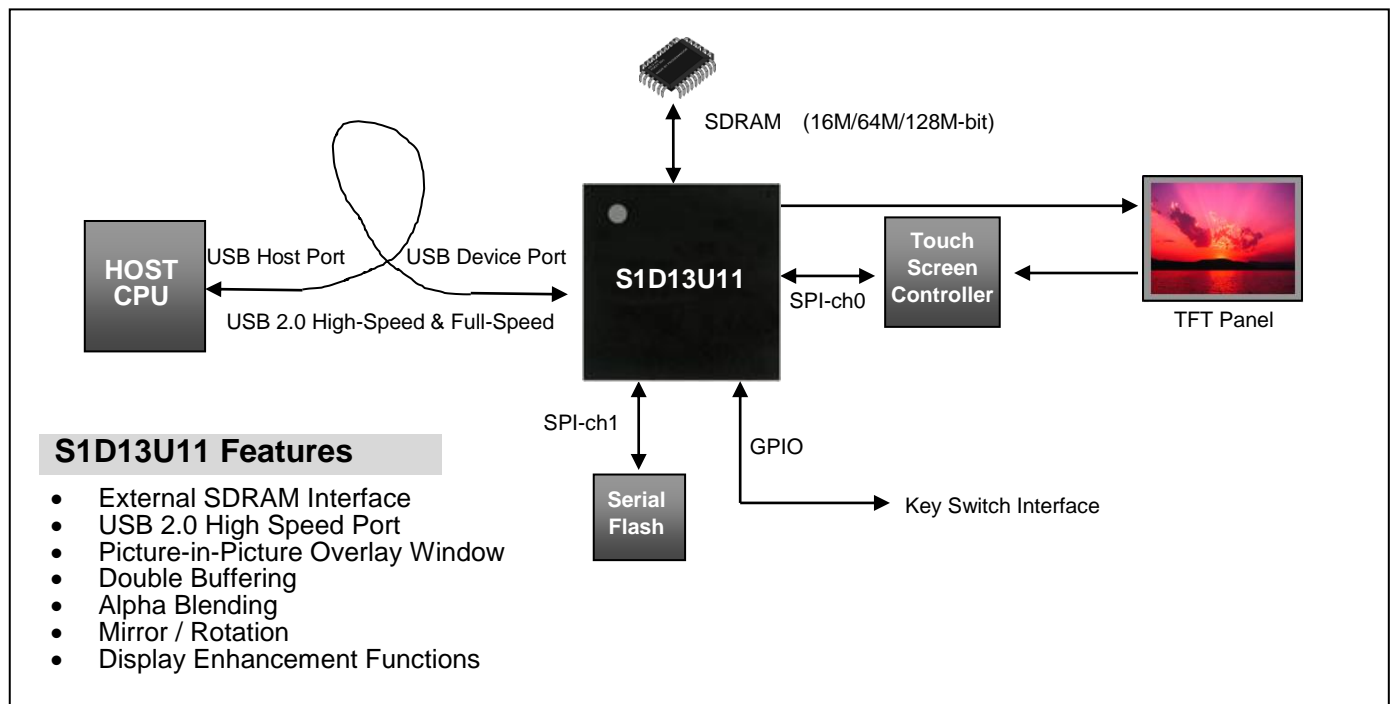

DESCRIPTION

Host Interface

- USB 2.0 High-speed device port (1-port)
- Endpoint
 - Five embedded endpoint FIFO
- Embedded Protocol sequencer
- RGB 8:8:8, RGB 5:6:5

Display Memory

- External SDRAM memory support:
 - 16/64/128M-bit
 - Maximum 96MHz SDRAM clock
 - 16-bit bus width

Display Support

- TFT panels:
 - 16/18/24-bit interface
- Supports resolutions up to 800x600 @ 24 bpp
- 24 bit-per-pixel (bpp) or 16 bpp color depths

Display Features

- Two Picture-in-Picture windows
- Software multi-buffer, Hardware double-buffer display
- Alpha Blending
- Mirror / Rotation functions
- Display Enhancement features
- Virtual display with smooth scroll

Miscellaneous

- I2C master interface
- Two SPI master interface
- Key scan interface (8x8, 8x4 or 8x2)
- PWM output for LED backlight control
- Buzzer output for touch screen feedback
- 12MHz or 24MHz crystal oscillator
- Internal programmable PLL (Maximum 96MHz)
- USBVDD 3.3 volts, IOVDD 3.3 volts and CORE/PLLVD 1.8 volts
- QFP20 144-pin package

For more information on the S1D13U11 and other Epson Display Controllers, visit the Epson Global website.

https://global.epson.com/products_and_drivers/semicon/products/display_controllers/



For Sales and Technical Support, contact the Epson representative for your region.

https://global.epson.com/products_and_drivers/semicon/information/support.html



NOTICE:

Document code: X96A-C-001-02.2

No part of this material may be reproduced or duplicated in any form or by any means without the written permission of Seiko Epson. Seiko Epson reserves the right to make changes to this material without notice. Seiko Epson does not assume any liability of any kind arising out of any inaccuracies contained in this material or due to its application or use in any product or circuit and, further, there is no representation that this material is applicable to products requiring high level reliability, such as, medical products. Moreover, no license to any intellectual property rights is granted by implication or otherwise, and there is no representation or warranty that anything made in accordance with this material will be free from any patent or copyright infringement of a third party. When exporting the products or technology described in this material, you should comply with the applicable export control laws and regulations and follow the procedures required by such laws and regulations. You are requested not to use, to resell, to export and/or to otherwise dispose of the products (and any technical information furnished, if any) for the development and/or manufacture of weapon of mass destruction or for other military purposes.

All brands or product names mentioned herein are trademarks and/or registered trademarks of their respective companies.

©Seiko Epson Corporation 2008 - 2018. All rights reserved.

Looking for pricing, stock, or lifecycle information?

Click below to explore more details on WIN SOURCE:

- ⊖ [View S5U13U11P00C100 on WIN SOURCE](#)
- ⊖ [Epson Electronics America Inc-Semiconductor Div Information](#)

Optimize Your Supply Chain with WIN SOURCE Solutions

- ✓ Global Sourcing Solution
- ✓ Obsolete Management
- ✓ Cost Control Management
- ✓ Shortage Management
- ✓ Alternative Solution
- ✓ Excess Inventory Management