



# THE DATASHEET OF STEVAL-IME002V1



## Multi-lead electrocardiogram (ECG) and body impedance demonstration board

Data brief

### Features

- Two power supply options: USB connector and external power connector
- Up to three HM301D: 12-lead ECG with bio-impedance measurement
- STG3692 low voltage high bandwidth quad SPDT switch to manage the HM301D SPI
- STM32F103CBT6: low power high performance 32-bit microcontroller powered by ARM® Cortex™-M3
- ESDALCL6-2SC6 provides ESD protection with very low capacitance
- USB 2.0 full-speed connection
- SWD/JTAG connector to program the MCU
- 37 debug test points to interact electrically with the ICs mounted on the board
- Reset button
- User LED and button
- Graphical user interface to manage HM301D and display data outputs
- Device firmware upgrade (DFU) procedure for easy upgrade of the STM32 firmware
- RoHS compliant

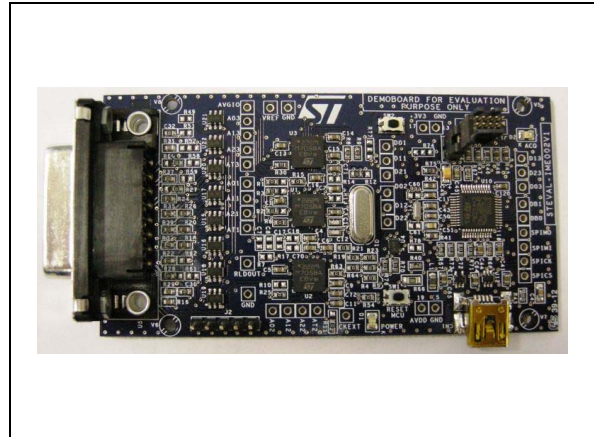

Any board can be used with a dedicated PC graphical user interface to demonstrate each of the various configurations.

### Description

The STEVAL-IME002V1 demonstration board is designed around the new HM301D diagnostic quality analog front end for bio-electric sensors and bio-impedance measurements.

This board is designed to demonstrate the use of HM301D in electrocardiographs (or patient monitoring systems).

It hosts a 32-bit microcontroller from the STM32 family which manages the SPI protocol of the HM301D, and the USB communication from/to the PC.

# 1 Schematic diagrams

Figure 1. HM301D section

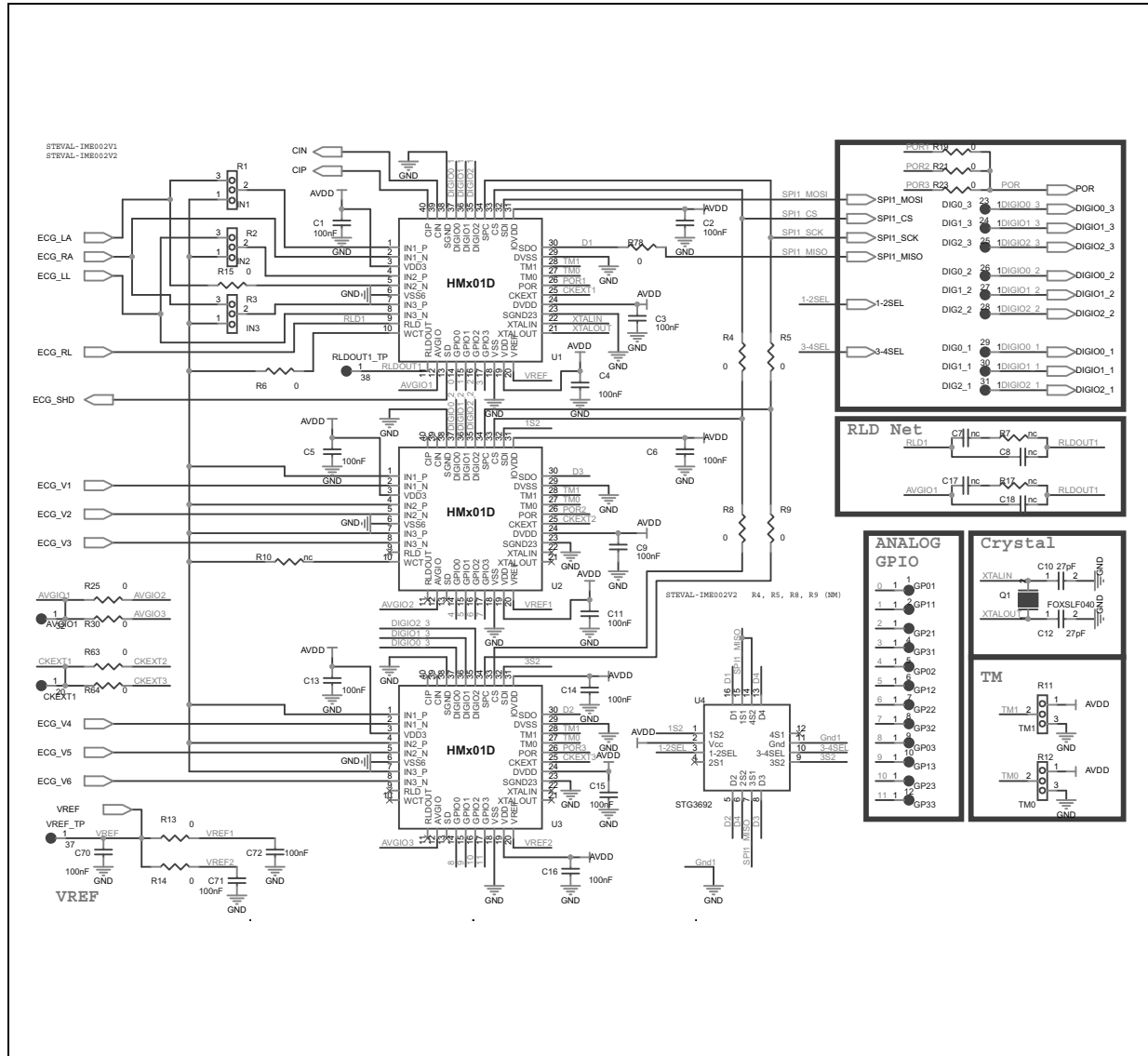

Figure 2. ECG connector section

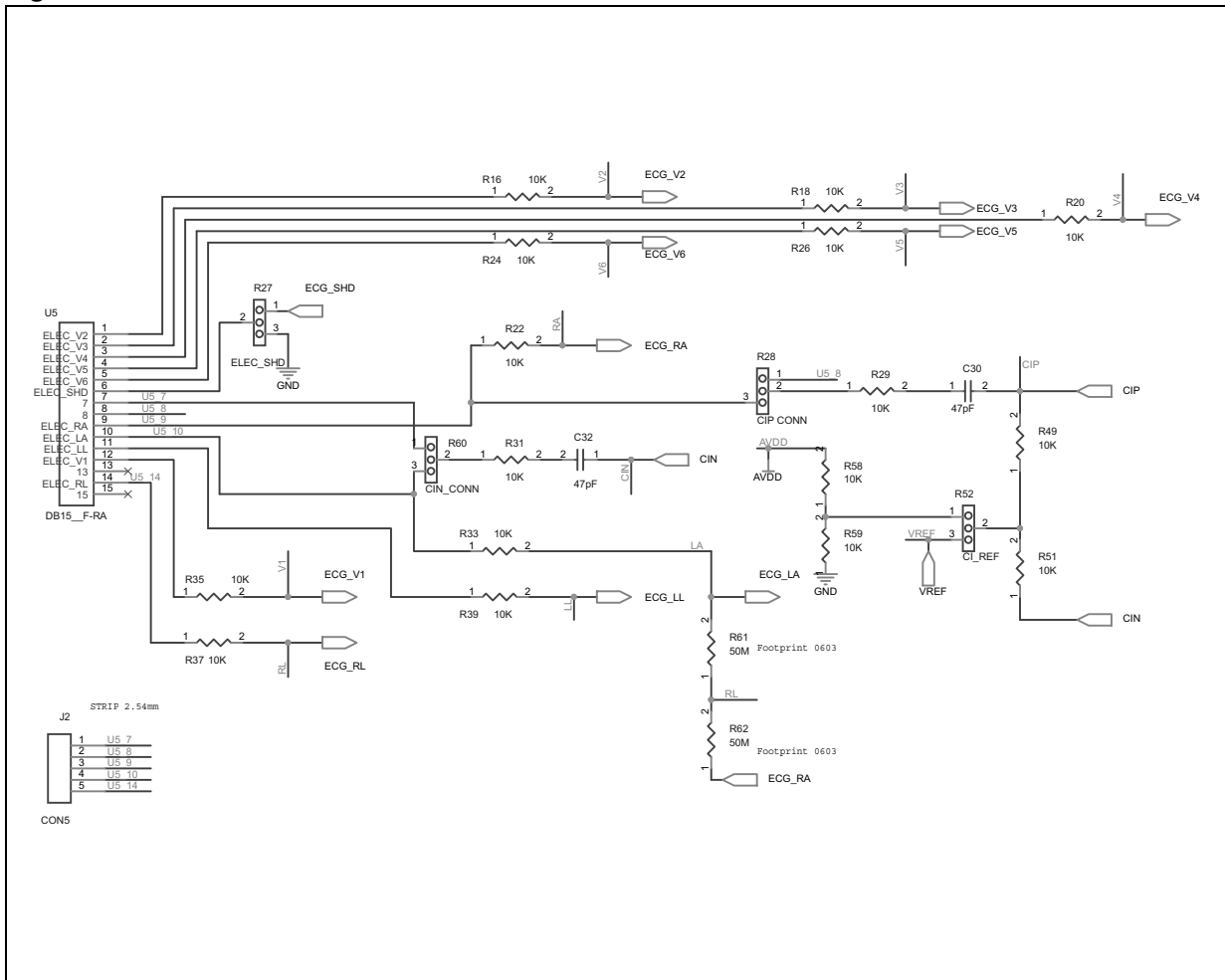

Figure 3. ESD protection

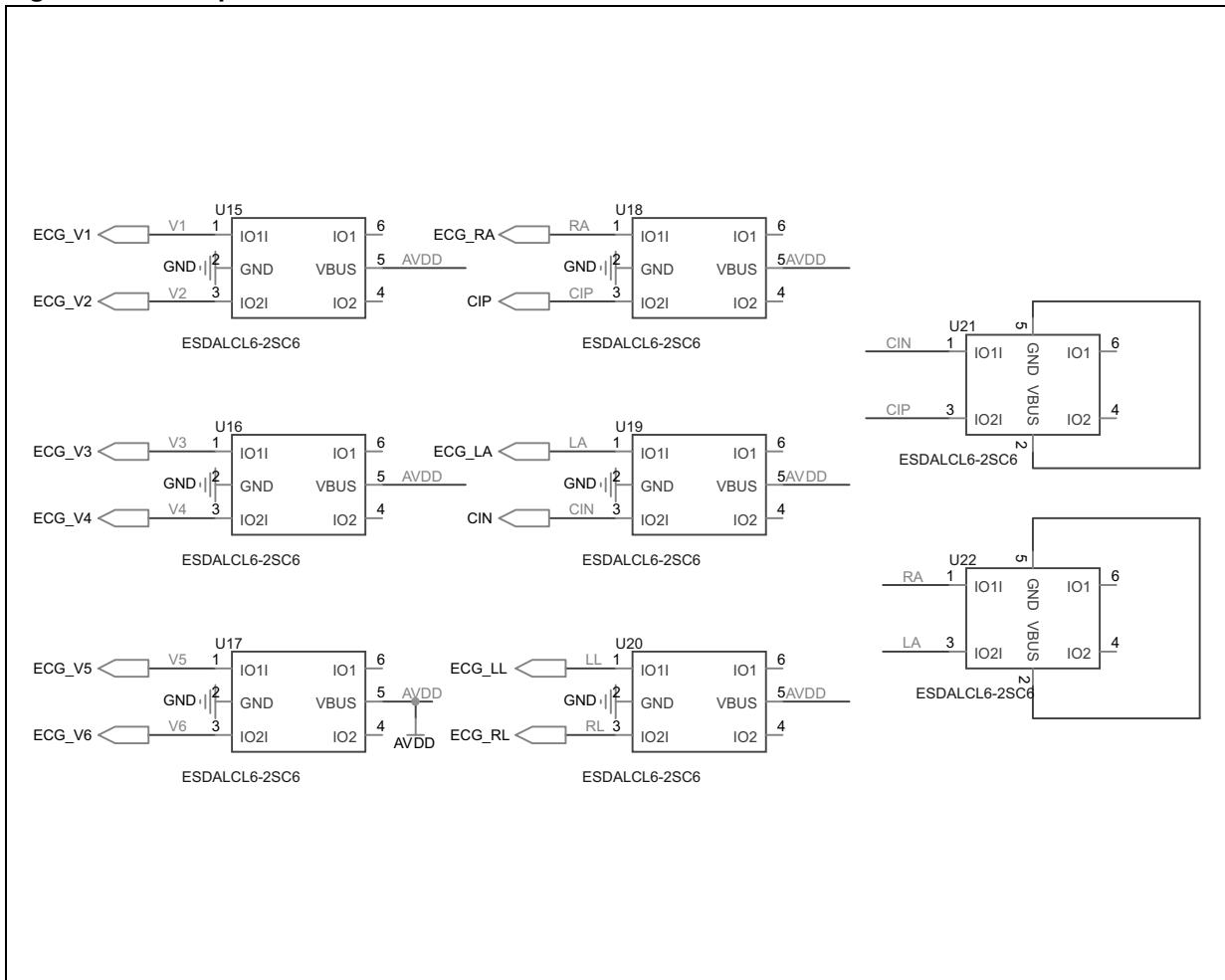

Figure 4. Connectors and buttons

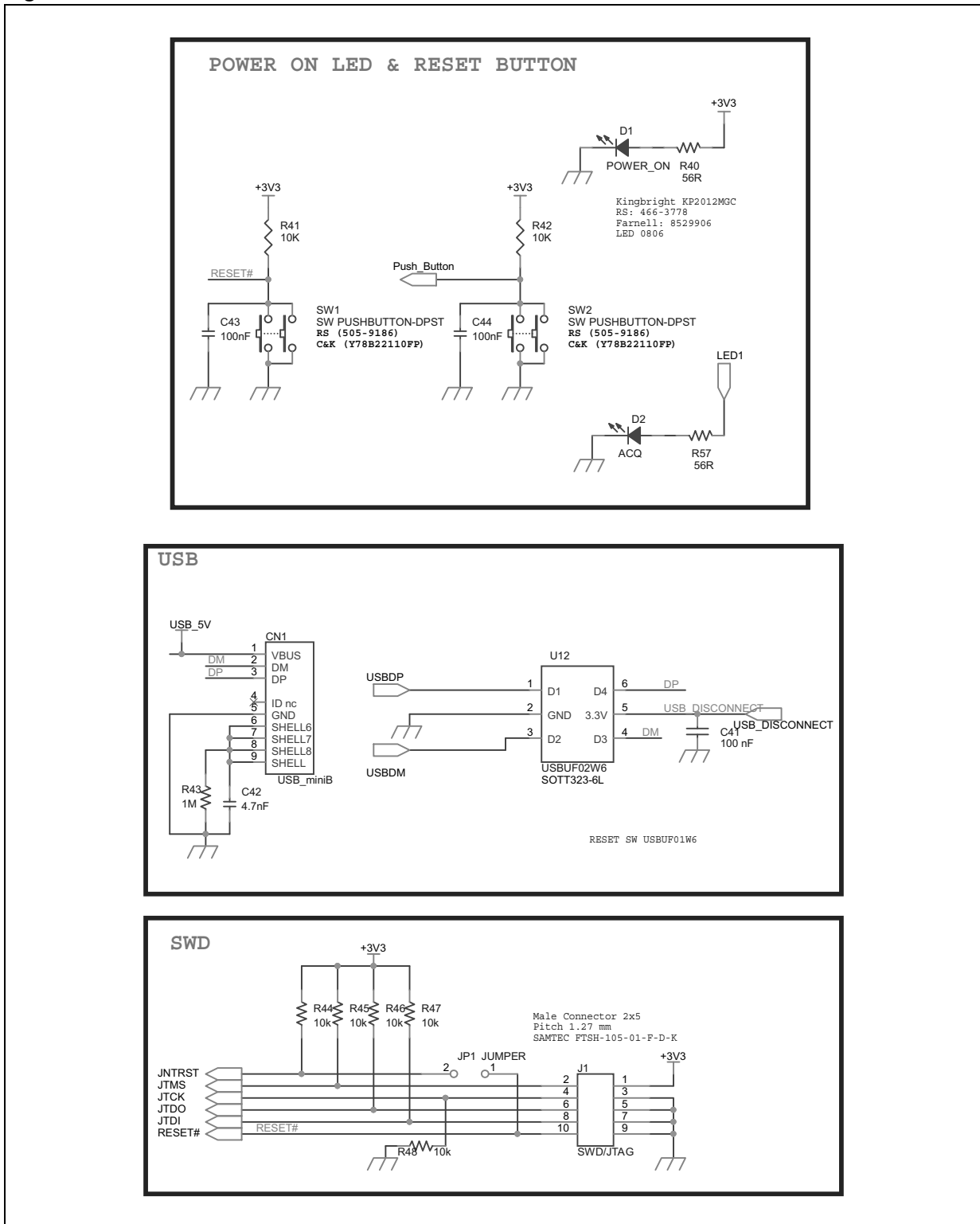

Figure 5. Microcontroller

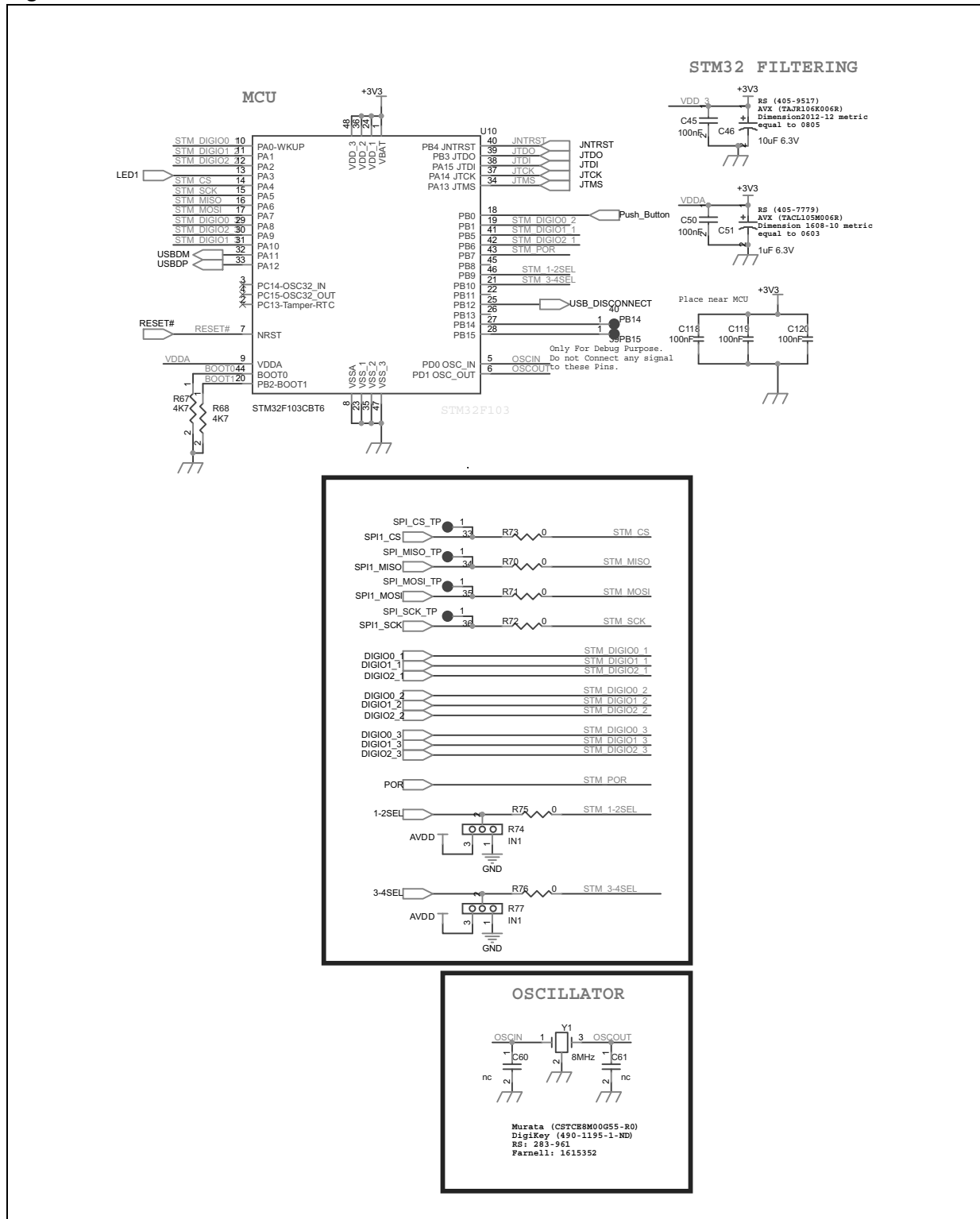
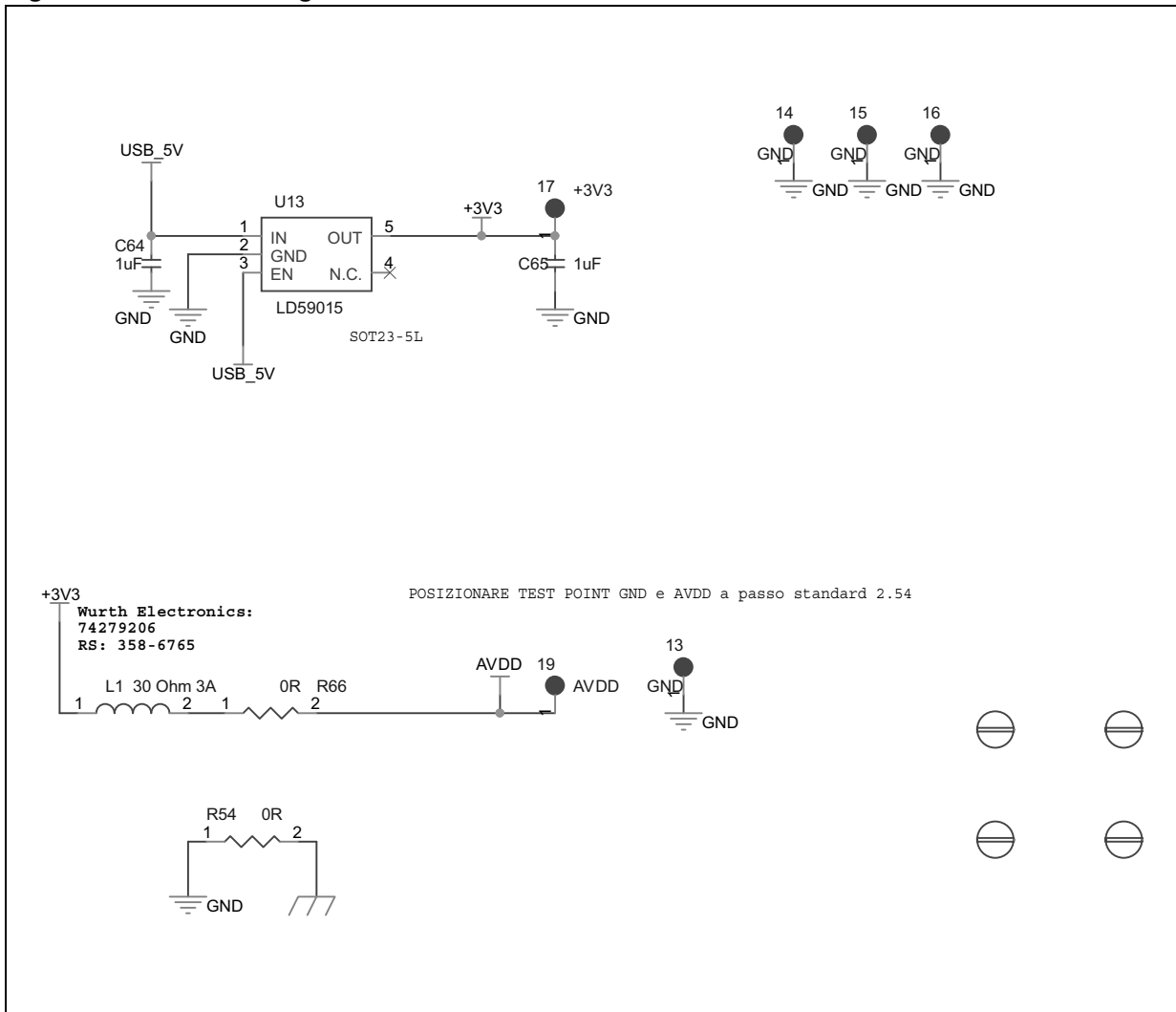

Figure 6. Power management



## 2 Revision history

Table 1. Document revision history

Date	Revision	Changes
11-Feb-2013	1	Initial release.

**Please Read Carefully:**

Information in this document is provided solely in connection with ST products. STMicroelectronics NV and its subsidiaries ("ST") reserve the right to make changes, corrections, modifications or improvements, to this document, and the products and services described herein at any time, without notice.

All ST products are sold pursuant to ST's terms and conditions of sale.

Purchasers are solely responsible for the choice, selection and use of the ST products and services described herein, and ST assumes no liability whatsoever relating to the choice, selection or use of the ST products and services described herein.

No license, express or implied, by estoppel or otherwise, to any intellectual property rights is granted under this document. If any part of this document refers to any third party products or services it shall not be deemed a license grant by ST for the use of such third party products or services, or any intellectual property contained therein or considered as a warranty covering the use in any manner whatsoever of such third party products or services or any intellectual property contained therein.

**UNLESS OTHERWISE SET FORTH IN ST'S TERMS AND CONDITIONS OF SALE ST DISCLAIMS ANY EXPRESS OR IMPLIED WARRANTY WITH RESPECT TO THE USE AND/OR SALE OF ST PRODUCTS INCLUDING WITHOUT LIMITATION IMPLIED WARRANTIES OF MERCHANTABILITY, FITNESS FOR A PARTICULAR PURPOSE (AND THEIR EQUIVALENTS UNDER THE LAWS OF ANY JURISDICTION), OR INFRINGEMENT OF ANY PATENT, COPYRIGHT OR OTHER INTELLECTUAL PROPERTY RIGHT.**

**UNLESS EXPRESSLY APPROVED IN WRITING BY TWO AUTHORIZED ST REPRESENTATIVES, ST PRODUCTS ARE NOT RECOMMENDED, AUTHORIZED OR WARRANTED FOR USE IN MILITARY, AIR CRAFT, SPACE, LIFE SAVING, OR LIFE SUSTAINING APPLICATIONS, NOR IN PRODUCTS OR SYSTEMS WHERE FAILURE OR MALFUNCTION MAY RESULT IN PERSONAL INJURY, DEATH, OR SEVERE PROPERTY OR ENVIRONMENTAL DAMAGE. ST PRODUCTS WHICH ARE NOT SPECIFIED AS "AUTOMOTIVE GRADE" MAY ONLY BE USED IN AUTOMOTIVE APPLICATIONS AT USER'S OWN RISK.**

Resale of ST products with provisions different from the statements and/or technical features set forth in this document shall immediately void any warranty granted by ST for the ST product or service described herein and shall not create or extend in any manner whatsoever, any liability of ST.

ST and the ST logo are trademarks or registered trademarks of ST in various countries.

Information in this document supersedes and replaces all information previously supplied.

The ST logo is a registered trademark of STMicroelectronics. All other names are the property of their respective owners.

© 2013 STMicroelectronics - All rights reserved

STMicroelectronics group of companies

Australia - Belgium - Brazil - Canada - China - Czech Republic - Finland - France - Germany - Hong Kong - India - Israel - Italy - Japan - Malaysia - Malta - Morocco - Philippines - Singapore - Spain - Sweden - Switzerland - United Kingdom - United States of America

[www.st.com](http://www.st.com)



## Looking for pricing, stock, or lifecycle information?

Click below to explore more details on WIN SOURCE:

- ⊖ [View STEVAL-IME002V1 on WIN SOURCE](#)
- ⊖ [STMicroelectronics Information](#)

## Optimize Your Supply Chain with WIN SOURCE Solutions

- ✓ Global Sourcing Solution
- ✓ Obsolete Management
- ✓ Cost Control Management
- ✓ Shortage Management
- ✓ Alternative Solution
- ✓ Excess Inventory Management