



# THE DATASHEET OF STEVAL-PCC005V1





# STEVAL-PCC005V1

## Hard disk drive (HDD) bridge demonstration board based on the STR9 microcontroller

Data Brief

### Features

- Based on the STR912 (ARM966E-S) microcontroller with in-built external memory interface (EMI)
- USB interface available for USB hard disk application
- Acts as mass-storage device using native Microsoft Windows® OS drivers
- On-board power supply for hard disk
- Option of using external power supply
- On-board JTAG connector for microcontroller firmware upgrade and changes
- Additional ESD protection device on USB
- LED indication for power, read and write operation and system health check



### Description

The STEVAL-PCC005V1 works as a USB-based hard disk implemented using the STR912FAW44 microcontroller. The board consists of two main sections: 1) the interface of the hard-disk to the STR912FAW44 through an external memory interface (EMI), and 2) the hard disk, appearing as a removable drive on the PC, which is made possible by USB mass-storage implementation.

The on-board power supply unit can be used for powering the hard disk. The board functions with a PC as the USB host. In addition to the on-board power supply, a separate SMPS power supply can be used to power the board and the hard disk.

The LEDs available on the demonstration board indicate read or write operation.

The board also features a JTAG interface for debugging purpose.



Figure 2. Schematic - USB, JTAG connectors

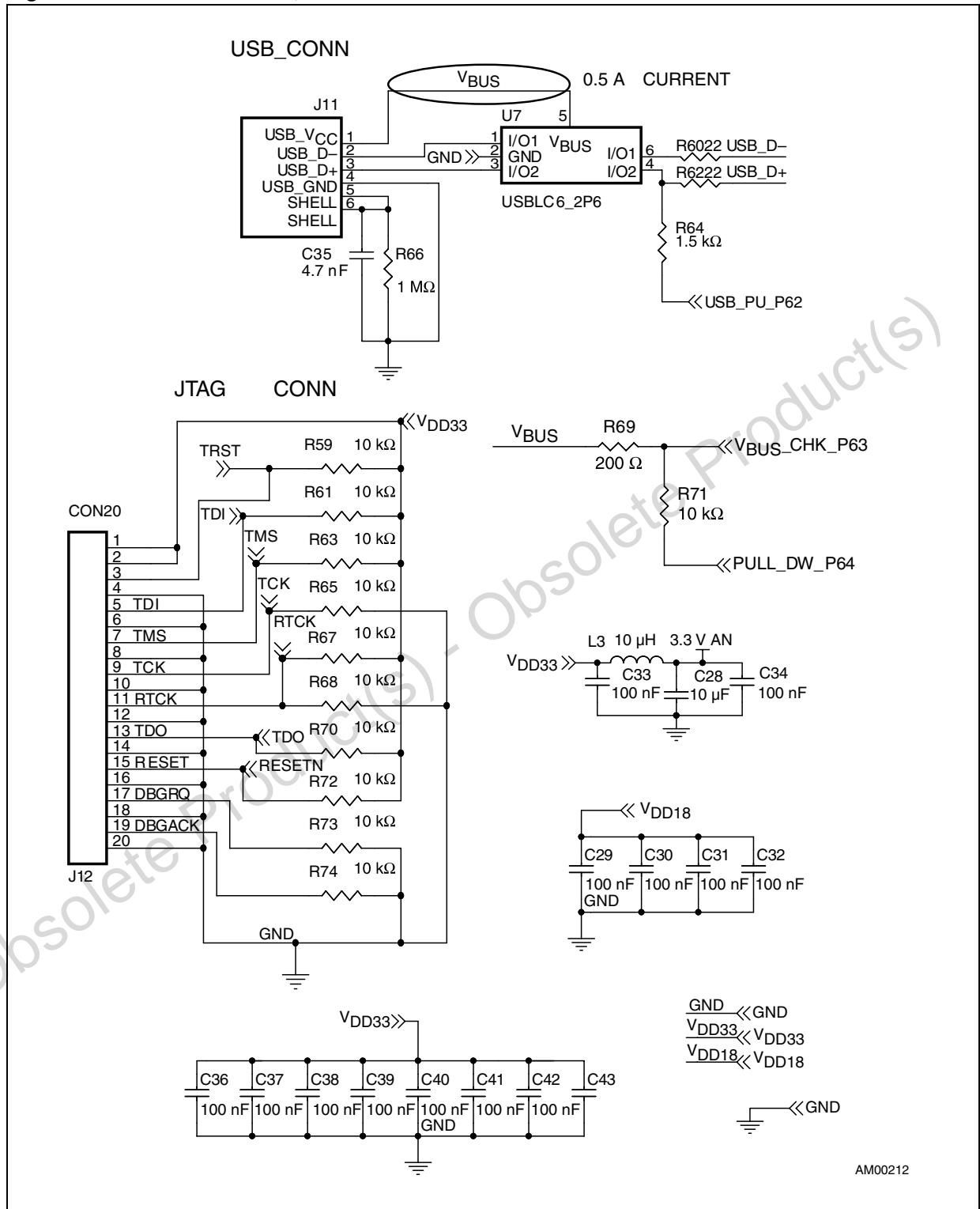

Figure 3. Schematic - STR9 hard disk interface

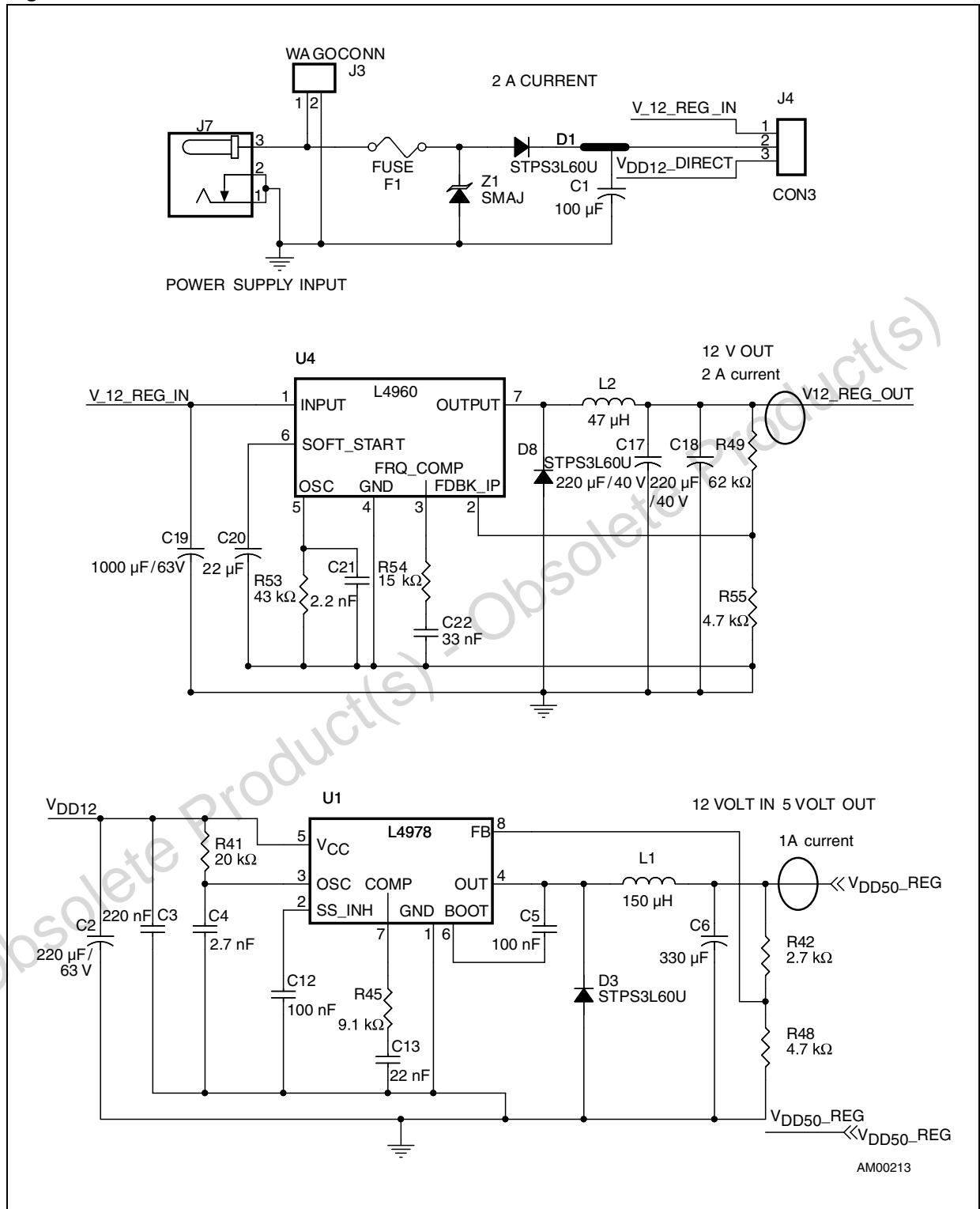

Figure 4. Schematic - STR9 hard disk interface

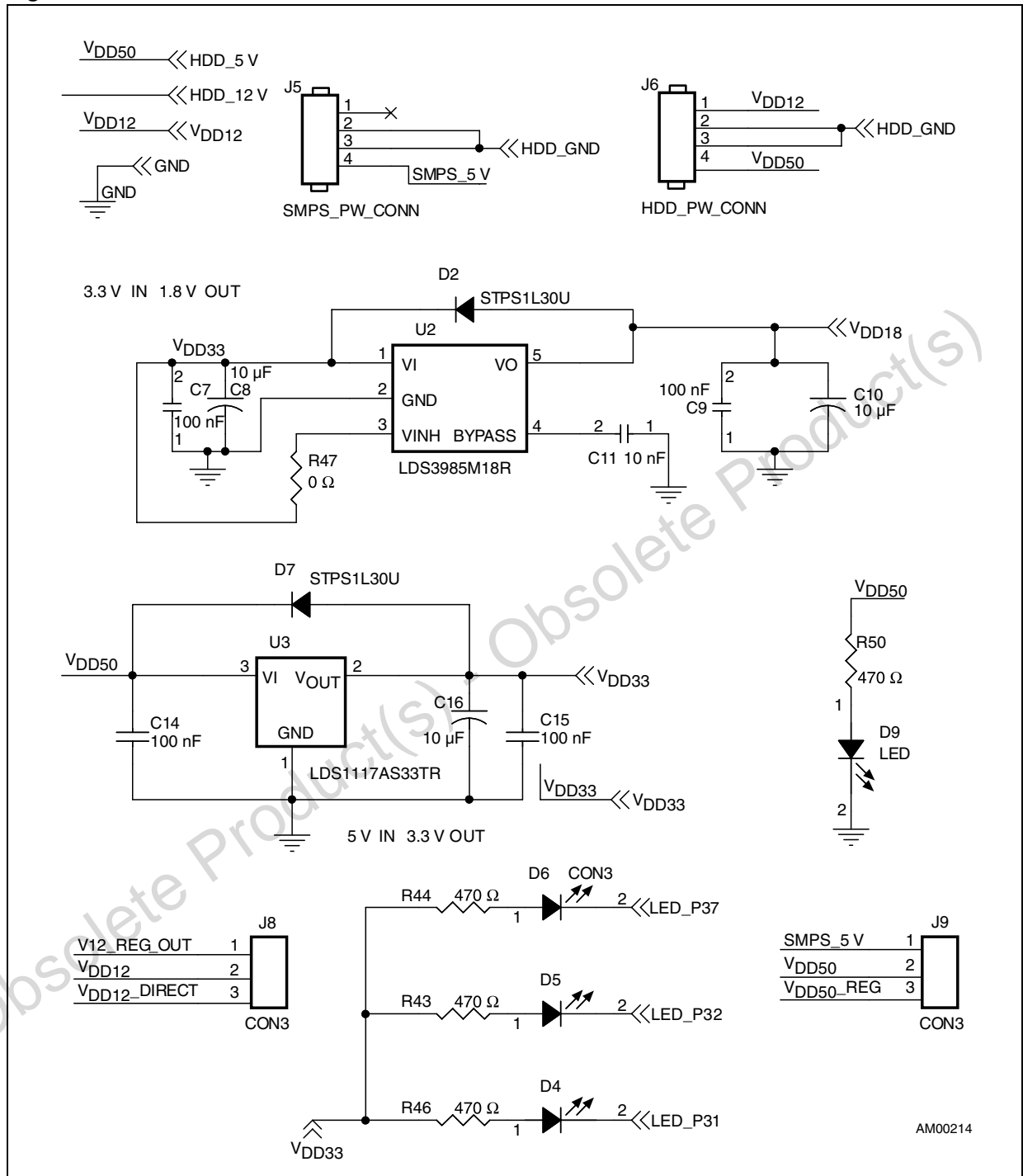
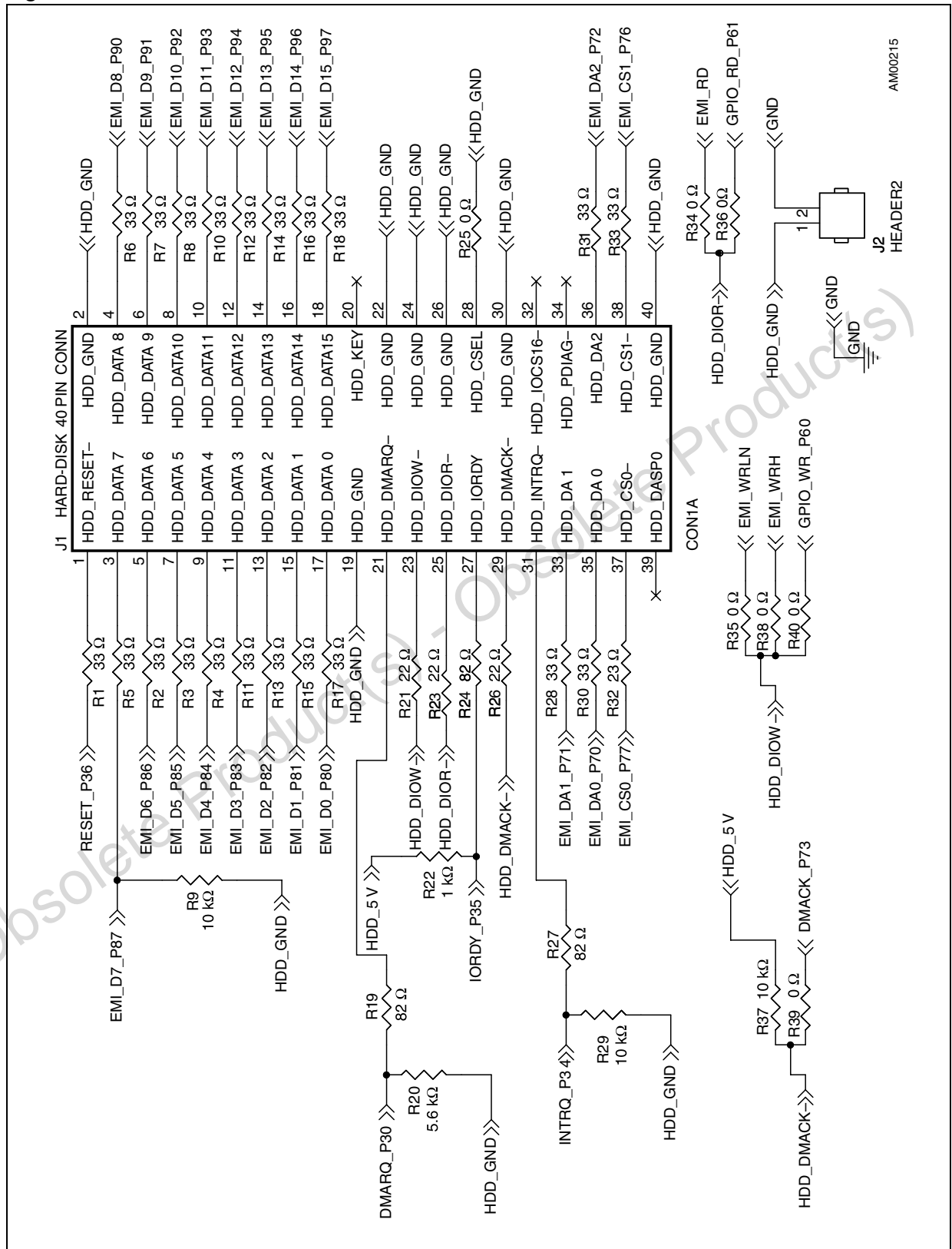

Figure 5. Schematic -hard disk connector with termination resistor



## 2 Revision history

Table 1. Document revision history

Date	Revision	Changes
02-Sep-2008	1	Initial release

Obsolete Product(s) - Obsolete Product(s)

**Please Read Carefully:**

Information in this document is provided solely in connection with ST products. STMicroelectronics NV and its subsidiaries ("ST") reserve the right to make changes, corrections, modifications or improvements, to this document, and the products and services described herein at any time, without notice.

All ST products are sold pursuant to ST's terms and conditions of sale.

Purchasers are solely responsible for the choice, selection and use of the ST products and services described herein, and ST assumes no liability whatsoever relating to the choice, selection or use of the ST products and services described herein.

No license, express or implied, by estoppel or otherwise, to any intellectual property rights is granted under this document. If any part of this document refers to any third party products or services it shall not be deemed a license grant by ST for the use of such third party products or services, or any intellectual property contained therein or considered as a warranty covering the use in any manner whatsoever of such third party products or services or any intellectual property contained therein.

**UNLESS OTHERWISE SET FORTH IN ST'S TERMS AND CONDITIONS OF SALE ST DISCLAIMS ANY EXPRESS OR IMPLIED WARRANTY WITH RESPECT TO THE USE AND/OR SALE OF ST PRODUCTS INCLUDING WITHOUT LIMITATION IMPLIED WARRANTIES OF MERCHANTABILITY, FITNESS FOR A PARTICULAR PURPOSE (AND THEIR EQUIVALENTS UNDER THE LAWS OF ANY JURISDICTION), OR INFRINGEMENT OF ANY PATENT, COPYRIGHT OR OTHER INTELLECTUAL PROPERTY RIGHT.**

**UNLESS EXPRESSLY APPROVED IN WRITING BY AN AUTHORIZED ST REPRESENTATIVE, ST PRODUCTS ARE NOT RECOMMENDED, AUTHORIZED OR WARRANTED FOR USE IN MILITARY, AIR CRAFT, SPACE, LIFE SAVING, OR LIFE SUSTAINING APPLICATIONS, NOR IN PRODUCTS OR SYSTEMS WHERE FAILURE OR MALFUNCTION MAY RESULT IN PERSONAL INJURY, DEATH, OR SEVERE PROPERTY OR ENVIRONMENTAL DAMAGE. ST PRODUCTS WHICH ARE NOT SPECIFIED AS "AUTOMOTIVE GRADE" MAY ONLY BE USED IN AUTOMOTIVE APPLICATIONS AT USER'S OWN RISK.**

Resale of ST products with provisions different from the statements and/or technical features set forth in this document shall immediately void any warranty granted by ST for the ST product or service described herein and shall not create or extend in any manner whatsoever, any liability of ST.

ST and the ST logo are trademarks or registered trademarks of ST in various countries.

Information in this document supersedes and replaces all information previously supplied.

The ST logo is a registered trademark of STMicroelectronics. All other names are the property of their respective owners.

© 2008 STMicroelectronics - All rights reserved



STMicroelectronics group of companies

Australia - Belgium - Brazil - Canada - China - Czech Republic - Finland - France - Germany - Hong Kong - India - Israel - Italy - Japan - Malaysia - Malta - Morocco - Singapore - Spain - Sweden - Switzerland - United Kingdom - United States of America

[www.st.com](http://www.st.com)

## Looking for pricing, stock, or lifecycle information?

Click below to explore more details on WIN SOURCE:

-  [View STEVAL-PCC005V1 on WIN SOURCE](#)
-  [STMicroelectronics](#) Information

## Optimize Your Supply Chain with WIN SOURCE Solutions

-  Global Sourcing Solution
-  Obsolete Management
-  Cost Control Management
-  Shortage Management
-  Alternative Solution
-  Excess Inventory Management