



**THE DATASHEET OF
SN75LVCP601EVM**



LVCP601 Evaluation Module

The SN75LVCP601 is a dual channel, single lane SATA redriver and signal conditioner supporting data rates up to 6.0Gbps. The device complies with SATA physical link 2m and 3i specifications.

The SN75LVCP601 handles interconnect losses at both its input and output. The input stage of each channel offers selectable equalization settings that can be programmed to match loss in the channel. The differential outputs provide selectable de-emphasis to compensate for the anticipated distortion the SATA signal will experience. Level of equalization and de-emphasis settings depend on the length of interconnect and its characteristics. Both equalization and de-emphasis levels are controlled by the setting of signal control pins EQ1, EQ2 and DE1, DE2.

This evaluation module acts as a reference design that can be easily modified for any intended application. Target applications include notebooks, desktops, docking stations, servers, and work stations. Schematics and layout information are included at the end of this user's guide.

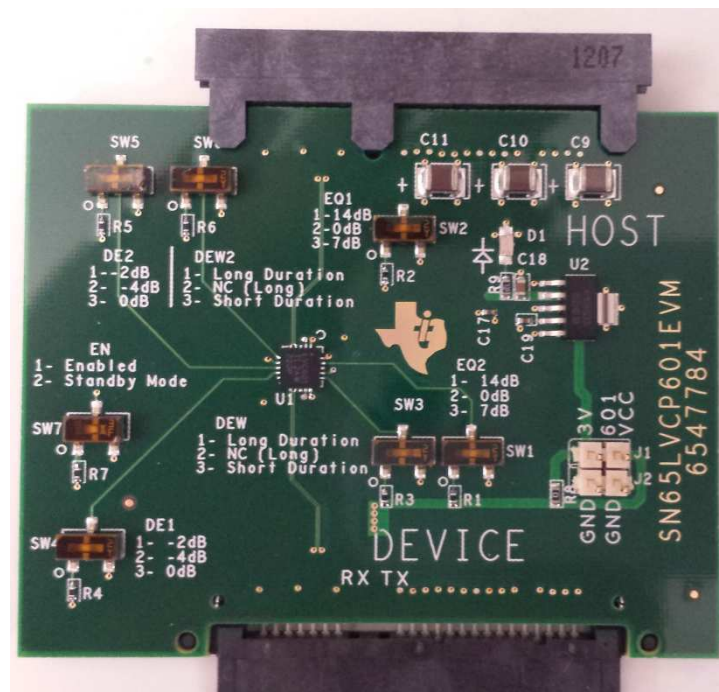

Figure 1. LVCP601 EVM

Contents

1	Introduction	3
2	LVCP601 Evaluation Module Configuration	3
3	PCB Construction	5
3.1	EVM Board Schematics	5
3.2	EVM PCB Layout	6
3.3	LVCP601 EVM Bill of Materials	8

List of Figures

1	LVCP601 EVM	1
2	SN75LVCP601 EVM Schematic	5
3	PCB Layout of Top Layer	6
4	PCB Layout of 2nd Layer	6
5	PCB Layout of 3rd Layer	7
6	PCB Layout of Bottom Layer	7

1 Introduction

The LVCP601 is a dual channel, single lane SATA redriver and signal conditioner. This guide describes the construction and usage of the EVM for the LVCP601 which is meant to serve as an evaluation tool for the LVCP601, as well as be used as a reference design for the device.

2 LVCP601 Evaluation Module Configuration

Kit Contents:

This EVM kit should contain the following items:

- LVCP601 EVM board
- This user's manual

This board is designed to facilitate easy evaluation of the LVCP601 using internal SATA connectors. Physical switches allow for simple configuration of the equalization, de-emphasis, and operation mode settings of the LVCP601. The EVM board has two internal SATA connectors, one for the host side and one for the device side of the redriver. This module also runs on a 3-V supply voltage that is derived from the standard SATA power connection.

The configuration of the equalization, de-emphasis, de-emphasis width, and standby mode settings are all selected using SW1-SW7. See [Table 1](#) for further details about the configuration of the EVM. Suggested default configuration settings for the EVM can be found in [Table 2](#).

Table 1. Configuration of EVM Using Control Switches

Control Switch	Switch Position and Corresponding Setting Configuration
SW1: EQ2 (Equalizer 2 configuration)	1: 14 dB
	2: 0 dB
	3: 7 dB
SW2: EQ1 (Equalizer 1 configuration)	1: 14 dB
	2: 0 dB
	3: 7 dB
SW3: DEW1 (De-emphasis width 1)	1: Long duration
	2: Long duration
	3: Short duration
SW4: DE1 (De-emphasis 1 configuration)	1: -2dB
	2: -4 dB
	3: 0 dB
SW5: DE2 (De-emphasis 2 configuration)	1: -2 dB
	2: -4 dB
	3: 0 dB
SW6: DEW2 (De-emphasis width 2)	1: Long duration
	2: Long duration
	3: Short duration
SW7: EN (Enable/Standby mode configuration)	1: Enabled
	2: Standby Mode
	3: Standby Mode

Table 2. Suggested Default Configuration for EVM

Parameter	Default Setting
EQ2	0 dB
EQ1	0 dB
DEW1	Long
DE1	0 dB
DE2	0 dB
DEW2	Long
EN	Enable Mode

3.2 EVM PCB Layout

Figure 3 through Figure 6 illustrate the PCB layouts.

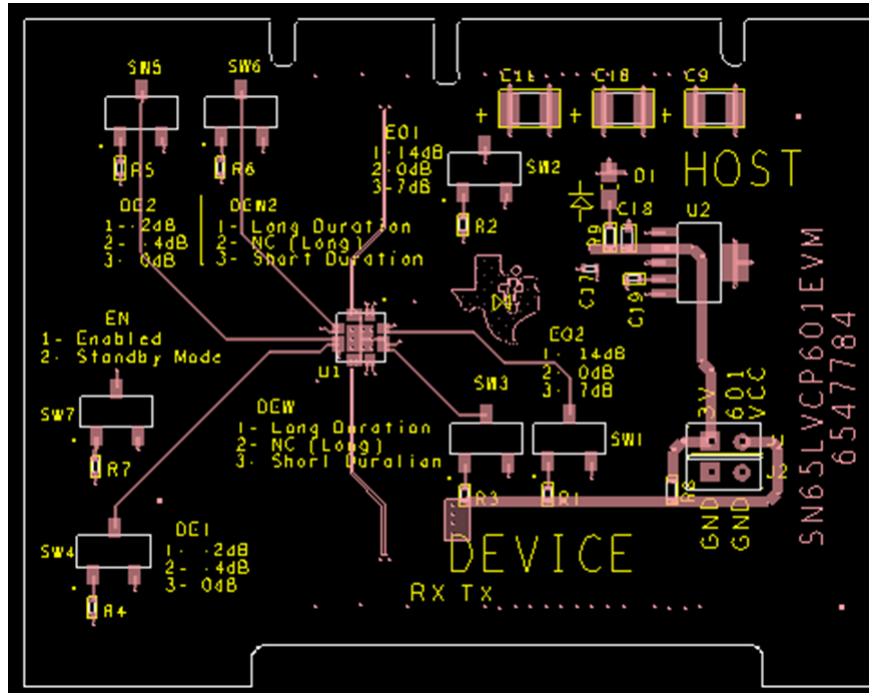

Figure 3. PCB Layout of Top Layer

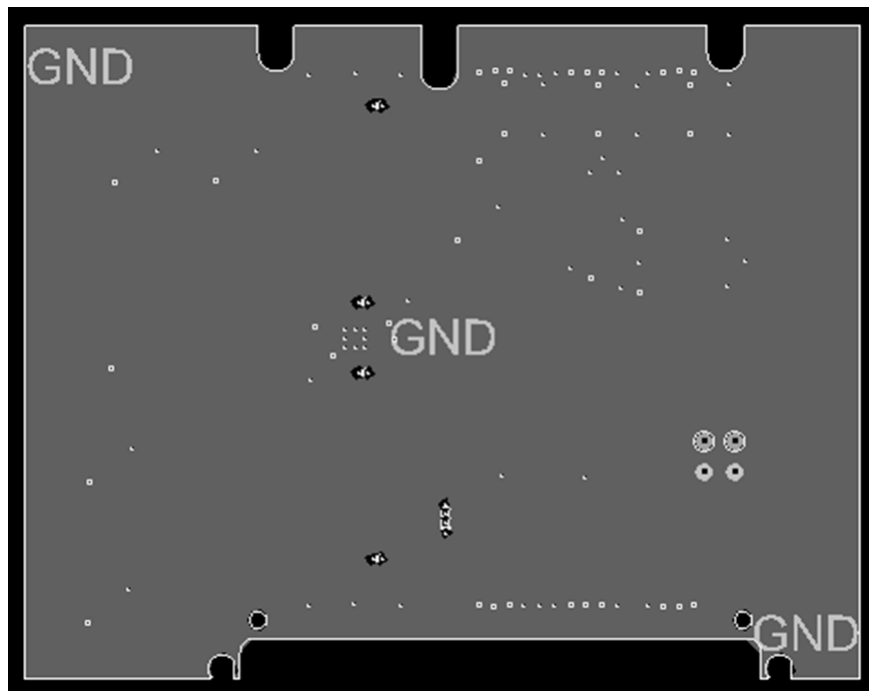

Figure 4. PCB Layout of 2nd Layer

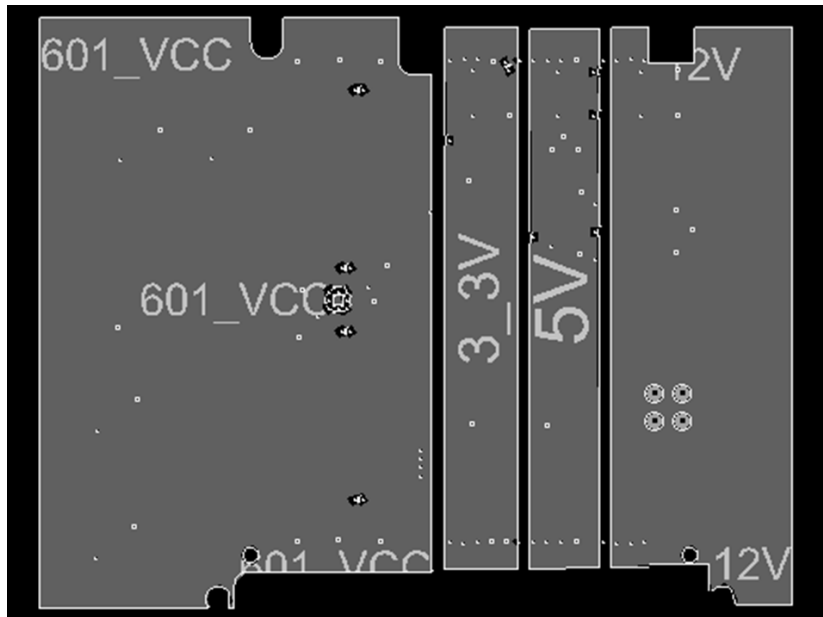

Figure 5. PCB Layout of 3rd Layer

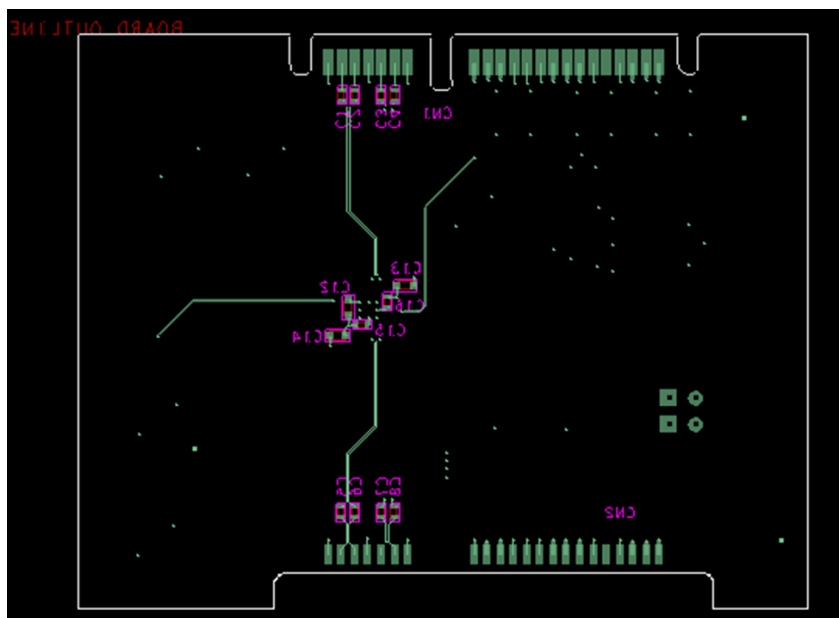

Figure 6. PCB Layout of Bottom Layer

3.2.1 EVM PCB Fabrication

The EVM board is a 4-layer board constructed of FR4-PolyClad 370 material. The board consists of a signal layer on top, a ground layer, a power layer, and another signal layer on the bottom. The impedance of the differential traces is 100 ohms. Other traces have an impedance of 50 ohms.

NOTE: In order to achieve the desired impedance, it is recommended that you consult your board manufacturer for their process and design requirements.

3.3 LVCP601 EVM Bill of Materials

Table 3 lists the SN75LVCP601 bill of materials.

Table 3. Bill of Materials

Item	Qty	Reference	Value	Digikey P/N	Manufacturer P/N
1	1	CN1	SATA MALE 5622-6309-ML	3M5555-ND	5622-6309-ML
2	1	CN2	SATA Female	609-1029-ND	10031569-001LF
3	8	C1,C2,C3,C4,C5,C6,C7,C8	.012uF	490-3255-1-ND	GRM155R71C123KA01D
4	3	C9,C10,C11	47uf	587-1436-1-ND	EMK325BJ476MM-T
5	2	C12,C18	10uF	445-4112-1-ND	C1608X5R0J106M
6	2	C13,C14	1uf	PCC2422CT-ND	ECJ-1VB1E105K
7	4	C15,C16,C17,C19	0.1uF	445-4984-1-ND	C1005X5R1A104M
8	1	D1	LED Green 0805	67-1553-6-ND	SML-LXT0805GW-TR
9	2	J1,J2	HDR2X1 M .1	A26520-02-ND	4-103321-0-02
10	7	R1,R2,R3,R4,R5,R6,R7	4.7K	P4.7KJCT-ND	ERJ-2GEJ472X
11	1	R8	0 Ohm	P0.0GCT-ND	ERJ-3GEY0R00V
12	1	R9	330 ohm	P330GCT-ND	ERJ-3GEYJ331V
13	6	SW1,SW2,SW3,SW4,SW5,SW6	Switch CJS-1201	563-1023-2-ND	CJS-1201B1
14	1	SW7	Switch CJS-1200	563-1022-1-ND	CJS-1200B1
15	1	U1	SN75LVCP601	296-27627-1-ND	SN75LVCP601RTJT
16	1	U2	REG104A-33	REG104GA-3.3-ND	REG104GA-3.3

IMPORTANT NOTICE

Texas Instruments Incorporated and its subsidiaries (TI) reserve the right to make corrections, enhancements, improvements and other changes to its semiconductor products and services per JESD46, latest issue, and to discontinue any product or service per JESD48, latest issue. Buyers should obtain the latest relevant information before placing orders and should verify that such information is current and complete. All semiconductor products (also referred to herein as "components") are sold subject to TI's terms and conditions of sale supplied at the time of order acknowledgment.

TI warrants performance of its components to the specifications applicable at the time of sale, in accordance with the warranty in TI's terms and conditions of sale of semiconductor products. Testing and other quality control techniques are used to the extent TI deems necessary to support this warranty. Except where mandated by applicable law, testing of all parameters of each component is not necessarily performed.

TI assumes no liability for applications assistance or the design of Buyers' products. Buyers are responsible for their products and applications using TI components. To minimize the risks associated with Buyers' products and applications, Buyers should provide adequate design and operating safeguards.

TI does not warrant or represent that any license, either express or implied, is granted under any patent right, copyright, mask work right, or other intellectual property right relating to any combination, machine, or process in which TI components or services are used. Information published by TI regarding third-party products or services does not constitute a license to use such products or services or a warranty or endorsement thereof. Use of such information may require a license from a third party under the patents or other intellectual property of the third party, or a license from TI under the patents or other intellectual property of TI.

Reproduction of significant portions of TI information in TI data books or data sheets is permissible only if reproduction is without alteration and is accompanied by all associated warranties, conditions, limitations, and notices. TI is not responsible or liable for such altered documentation. Information of third parties may be subject to additional restrictions.

Resale of TI components or services with statements different from or beyond the parameters stated by TI for that component or service voids all express and any implied warranties for the associated TI component or service and is an unfair and deceptive business practice. TI is not responsible or liable for any such statements.

Buyer acknowledges and agrees that it is solely responsible for compliance with all legal, regulatory and safety-related requirements concerning its products, and any use of TI components in its applications, notwithstanding any applications-related information or support that may be provided by TI. Buyer represents and agrees that it has all the necessary expertise to create and implement safeguards which anticipate dangerous consequences of failures, monitor failures and their consequences, lessen the likelihood of failures that might cause harm and take appropriate remedial actions. Buyer will fully indemnify TI and its representatives against any damages arising out of the use of any TI components in safety-critical applications.

In some cases, TI components may be promoted specifically to facilitate safety-related applications. With such components, TI's goal is to help enable customers to design and create their own end-product solutions that meet applicable functional safety standards and requirements. Nonetheless, such components are subject to these terms.

No TI components are authorized for use in FDA Class III (or similar life-critical medical equipment) unless authorized officers of the parties have executed a special agreement specifically governing such use.

Only those TI components which TI has specifically designated as military grade or "enhanced plastic" are designed and intended for use in military/aerospace applications or environments. Buyer acknowledges and agrees that any military or aerospace use of TI components which have **not** been so designated is solely at the Buyer's risk, and that Buyer is solely responsible for compliance with all legal and regulatory requirements in connection with such use.

TI has specifically designated certain components as meeting ISO/TS16949 requirements, mainly for automotive use. In any case of use of non-designated products, TI will not be responsible for any failure to meet ISO/TS16949.

Products

Audio	www.ti.com/audio
Amplifiers	amplifier.ti.com
Data Converters	dataconverter.ti.com
DLP® Products	www.dlp.com
DSP	dsp.ti.com
Clocks and Timers	www.ti.com/clocks
Interface	interface.ti.com
Logic	logic.ti.com
Power Mgmt	power.ti.com
Microcontrollers	microcontroller.ti.com
RFID	www.ti-rfid.com
OMAP Applications Processors	www.ti.com/omap
Wireless Connectivity	www.ti.com/wirelessconnectivity

Applications

Automotive and Transportation	www.ti.com/automotive
Communications and Telecom	www.ti.com/communications
Computers and Peripherals	www.ti.com/computers
Consumer Electronics	www.ti.com/consumer-apps
Energy and Lighting	www.ti.com/energy
Industrial	www.ti.com/industrial
Medical	www.ti.com/medical
Security	www.ti.com/security
Space, Avionics and Defense	www.ti.com/space-avionics-defense
Video and Imaging	www.ti.com/video

TI E2E Community

e2e.ti.com

Looking for pricing, stock, or lifecycle information?

Click below to explore more details on WIN SOURCE:

 [View SN75LVCP601EVM on WIN SOURCE](#)

 [Texas Instruments](#) Information

Optimize Your Supply Chain with WIN SOURCE Solutions

-  Global Sourcing Solution
-  Obsolete Management
-  Cost Control Management
-  Shortage Management
-  Alternative Solution
-  Excess Inventory Management