



THE DATASHEET OF SERDESUB-21USB/NOPB



SERDESUB-21USB User's Guide

Table of Contents

TABLE OF CONTENTS.....	1
INTRODUCTION:.....	2
CONTENTS OF THE DEMO EVALUATION KIT:	3
DS90UB903Q/904Q SERDES TYPICAL APPLICATION:	3
HOW TO SET UP THE DEMO EVALUATION KIT:	5
BI-DIRECTIONAL CONTROL BUS AND I²C MODES:	6
DEMO BOARD POWER CONNECTIONS:	6
DS9UB903Q SERIALIZER BOARD DESCRIPTION:.....	7
CONFIGURATION SETTINGS FOR THE SERIALIZER DEMO BOARD	8
SERIALIZER LVCMOS AND FPD-LINK III PINOUT BY CONNECTOR	12
DS9UB904Q DESERIALIZER BOARD DESCRIPTION:.....	13
CONFIGURATION SETTINGS FOR THE DESERIALIZER DEMO BOARD	14
DESERIALIZER FPD-LINK III PINOUT AND LVCMOS BY CONNECTOR	18
TYPICAL CONNECTION AND TEST EQUIPMENT	19
EVALUATION OF THE BI-DIRECTIONAL CONTROL CHANNEL.....	20
DISPLAY MODE:	20
I ² C COMMUNICATION OVER BI-DIRECTIONAL CONTROL CHANNEL IN DISPLAY MODE	22
CAMERA MODE:	24
I ² C COMMUNICATION OVER BI-DIRECTIONAL CONTROL CHANNEL IN CAMERA MODE	27
FIGURE 7. BI-DIRECTIONAL CONTROL CHANNEL FLOWCHART IN CAMERA MODE	
TROUBLESHOOTING DEMO SETUP	28
TROUBLESHOOTING DEMO SETUP	29
CABLE REFERENCES	30
APPENDIX	31
SERIALIZER AND DESERIALIZER DEMO PCB SCHEMATICS:	31
BOM (BILL OF MATERIALS) SERIALIZER DEMO PCB:	40
BOM (BILL OF MATERIALS) DESERIALIZER DEMO PCB:	41
SERIALIZER (Tx) DEMO PCB LAYOUT:	42
SERIALIZER (Tx) DEMO PCB STACKUP:	45
DESERIALIZER (Rx) DEMO PCB LAYOUT:	46
DESERIALIZER (Rx) DEMO PCB STACKUP:	49

Introduction:

Texas Instruments' Automotive Serdes DS90UB903Q/904Q FPD-Link III evaluation kit contains one (1) DS90UB903Q Serializer board, one (1) DS90UB904Q Deserializer board, and one (1) two (2) meter* high speed USB 2.0 cable. **Note: the chipset can support up to ten (10) meters.*

The DS90UB903Q/904Q chipset supports a variety of automotive display or vision applications over a two (2) wire serial stream. The single differential pair (FPD-Link III) is well-suited for direct connections between a Host Controller/Electronic Control Unit (ECU)/FPGA and a display module. The bidirectional control channel of the DS90UB903Q/904Q provides seamless communication between the ECU/FPGA and the display module. Interactive display platforms such as touch screens can be built around this chipset.

This kit will demonstrate the functionality and operation of the DS90UB903Q and DS90UB904Q chipset. The chipset enables transmission of a high-speed video data along with a low latency bi-directional control bus over a single twisted pair cable. The integrated control channel transfers data bi-directionally over the same serial video link. The transport delivers 21 bits of parallel data together with a bidirectional control channel that supports an I²C bus. Additionally, there are four unidirectional general purpose (GPI and GPO) signal lines for sending control data. This interface allows transparent full-duplex communication over a single high-speed differential pair, carrying asymmetrical bi-directional control information without the dependency of video blanking intervals. The Serializer and Deserializer chipset is designed to transmit data at PCLK clocks speeds ranging from 10 to 43 MHz and I²C bus rates up to 100 kbps at up to 10 meters cable length over -40 to +105 Deg C.

The Serializer board accepts 1.8V/3.3V parallel input signals. FPD-Link III Serializer converts the 1.8V/3.3V LVCMOS parallel lines into a single serialized data pair with an embedded clock. The serial data line rate switches at 28 times the base clock frequency. With an input clock at 43 MHz, the transmission line rate for the FPD-Link III is 1.20Gbps (28 x 43MHz).

The user needs to provide the proper 1.8V/3.3V LVCMOS inputs and 1.8V/3.3V LVCMOS clock to the Serializer and also provide a proper interface from the Deserializer output to test equipment. The Serializer and Deserializer boards can also be used to evaluate device parameters. A cable conversion board or harness scramble may be necessary depending on type of cable/connector interface used on the input to the DS90UB903Q and to the output of the DS90UB904Q.

The demo boards are not intended for EMI testing. The demo boards were designed for easy accessibility to device pins with tap points for monitoring or applying signals, additional pads for termination, and multiple connector options.

System Requirements:

In order to demonstrate, the following are required:

- 1) Display module with 1.8V or 3.3V LVCMOS parallel interface
- 2) Microcontroller (MCU) or FPGA with I²C interface bus (I²C master)
 - a. slave clock stretching must be supported by the I²C master controller/MCU.
- 3) External peripheral device that supports I²C (slave mode)
- 4) Power supply for 1.8V (required) and 3.3V (optional)

Contents of the Demo Evaluation Kit:

- 1) One Serializer board with the DS90UB903Q
- 2) One Deserializer board with the DS90UB904Q
- 3) One 2-meter high speed USB 2.0 cable (4-pin USB A to 5-pin mini USB)
- 4) Evaluation Kit Documentation (this manual)
- 5) DS90UB903Q/904Q Datasheet

DS90UB903Q/904Q Serdes Typical Application:

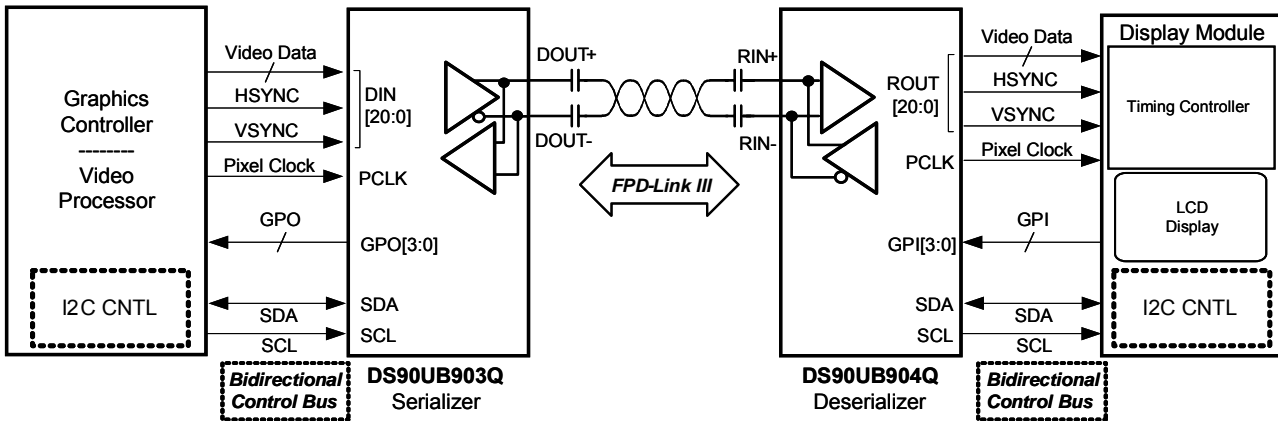

Figure 1. Typical Application

The diagram above illustrates a typical application of DS90UB903Q/904Q chipset. The MCU/FPGA can program device registers on the DS90UB903Q, DS90UB904Q, and remote peripheral device, such as a display module.

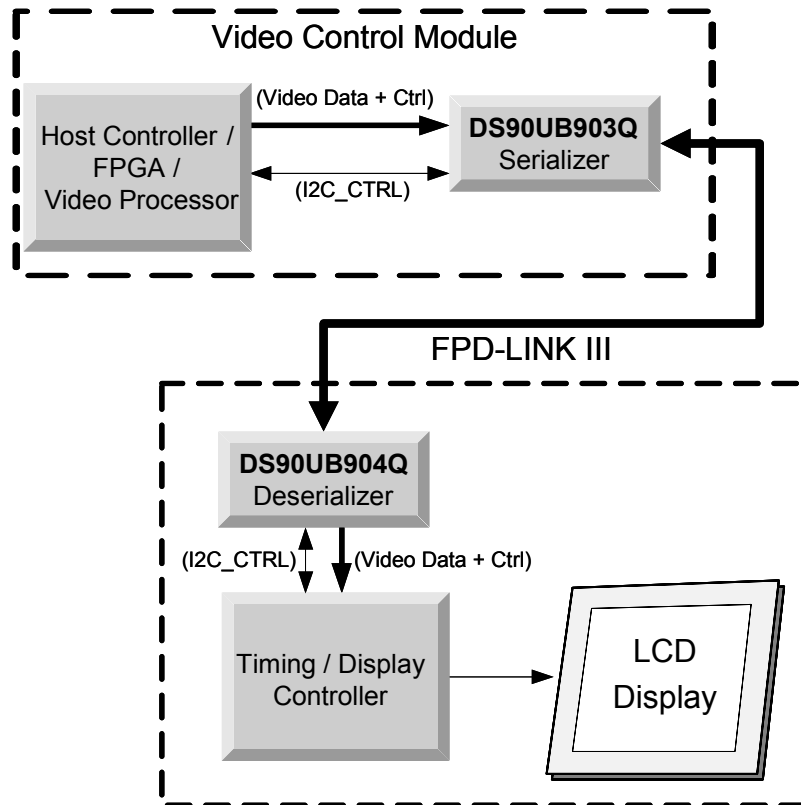

Figure 2. Typical DS90UB903Q/904Q Display System Diagram

Figure 1 and **Figure 2** illustrate the use of the Chipset (Serializer/Deserializer) in a Host (MCU/FPGA) Controller to display module.

Refer to the proper datasheet information on Chipsets (Serializer/Deserializer) provided on each board for more detailed information.

How to set up the Demo Evaluation Kit:

The DS90UB903Q/904Q evaluation boards consist of two sections. The first part of the board provides the point-to-point interface for transmitting parallel video data. The second part of the board allows bi-directional control communication of an I²C bus control of using a MCU/FPGA to programming a remote peripheral device via the Serializer.

The PCB routing for the Serializer input pins (DIN) accept incoming parallel video data at 1.8V/3.3V LVCMOS signals from J1 IDC connector. The FPD-Link III interface uses a single twisted pair cable (provided). The output pins (ROUT) are accessed through a J7 IDC connector. Please follow these steps to set up the evaluation kit for bench testing and performance measurements:

- 1) A two (2) meter high speed USB 2.0 cable has been included in the kit. Connect the 4-

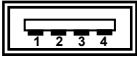
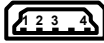
pin USB A  **A** side of cable harness to the serializer board and the other side of the harness, the 5-pin mini USB jack  **MINI** to the Deserializer board. This completes the FPD-Link III interface connection.

NOTE: The DS9UB903Q and DS9UB904Q are NOT USB compliant and should not be plugged into a USB device nor should a USB device be plugged into the demo boards.

- 2) Jumpers and switches have been configured at the factory; they should not require any changes for immediate operation of the chipset. See text on Configuration settings and datasheet for more details.
- 3) From the controller, connect a flat cable (not supplied) to the Serializer board and connect another flat cable (not supplied) from the Deserializer board to the display module. *Note: For 50 ohm signal sources, provide 1.8V/3.3V LVCMOS input signal levels into DIN[20:0] and PCLK and add 50 ohm parallel termination resistors R1-R22 on the DS9UB903Q Serializer board.*
- 4) Connect the Serializer I²C ports to the I²C of the MCU/FPGA (I²C master). Connect the Deserializer I²C ports to the I²C bus of the peripheral slave device.
- 5) Power for the Serializer and Deserializer boards must be supplied externally through Power Jack (VDD). Grounds for both boards are connected through Power Jack (VSS) (see section below).

Bi-Directional Control Bus And I²C Modes:

In order to communicate and synchronize with remote devices on the I²C bus through the bi-directional control channel, slave clock stretching must be supported by the I²C master controller/MCU. The chipset utilizes bus clock stretching (holding the SCL line low) during data transmission; where the I²C slave pulls the SCL line low prior to the 9th clock of every I²C data transfer (before the ACK signal).

The bidirectional control bus supports an I²C compatible interface that allows programming of the DS90UB903Q, DS90UB904Q, or an external remote device (such as a camera or display). Register programming transactions to/from the DS90UB903Q/904Q chipset are employed through the clock (SCL) and data (SDA) lines. These two signals have open drain I/Os and must be pulled-up to VDDIO by external resistors. The boards have an option to use the on-board 1.0K Ω pull-up resistors tied to VDDIO or connected through external pull-ups at the target Host. The appropriate pull-up resistor values will depend upon the total bus capacitance and operating speed. The DS90UB903Q/904Q I²C bus data rate supports up to 100 kbps according to I²C specification.

To start any data transfer, the DS90UB903Q/904Q must be configured in the proper I²C mode. Each device can function as an I²C slave proxy or master proxy depending on the mode determined by MODE (M_S) pin. Note the MODE pin is label as M_S on the PCB boards. The Ser/Des interface acts as a virtual bridge between Master controller (MCU) and the remote device. When the MODE (M_S) pin is set to High, the device is treated as a slave proxy; acts as a slave on behalf of the remote slave. When addressing a remote peripheral or Serializer/Deserializer (not wired directly to the MCU), the slave proxy will forward any byte transactions sent by the Master controller to the target device. When MODE (M_S) pin is set to Low, the device will function as a master proxy device; acts as a master on behalf of the I²C master controller. Note that the devices must have complementary settings for the MODE configuration. For example, if the Serializer MODE (M_S) pin is set to High then the Deserializer MODE (M_S) pin must be set to Low and vice-versa.

Demo Board Power Connections:

The Serializer and Deserializer boards must be powered by supplying power externally through J5 (VDD) and J6 (VSS) on Serializer Board and J8 (VDD) and J9 (VSS) on Deserializer board. Note +2.5V is the MAXIMUM voltage that should ever be applied to the Serializer J5 or Deserializer J8 VDD terminal. Serializer JP12 VDDIO and Deserializer VDDIO JP13 must never exceed +4.0V. Damage to the device(s) can result if the voltage maximum is exceeded.

DS9UB903Q Serializer Board Description:

The 2x22-pin IDC connector J1 accepts 21 bits of 1.8V or 3.3V data along with the PCLK clock input. VDDIO must be set externally for 1.8V or 3.3V LVCMOS inputs.

The Serializer board is powered externally from the J5 (VDD) and J6 (VSS) connectors shown below. For the Serializer to be operational, the S1-PDB switch on S1 must be set HIGH. S1-RES0 must be set LOW. Master or slave mode is user selected on S1-M_S (MODE). please refer to DS90UB903/904 datasheet for details.

The USB connector P2 (USB-A side) on the bottom side of the board provides the interface connection to the Deserializer board. Note: P3 (mini USB) on the top side is un-stuffed and not to be used with the cable provided in the kit.

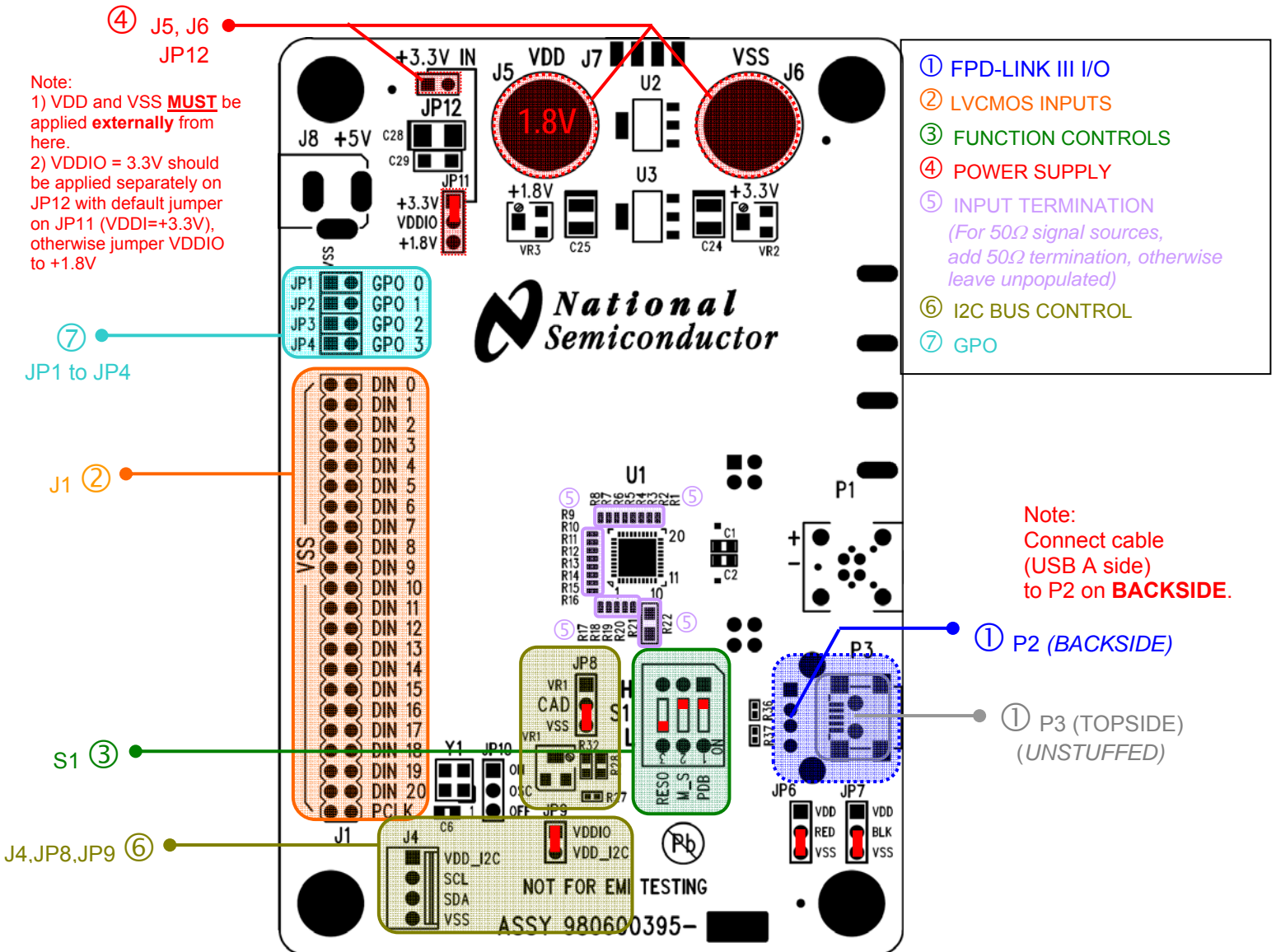

Configuration Settings for the Serializer Demo Board

VDDIO: 1.8V or 3.3V LVCMOS INPUT/OUTPUT SELECTION

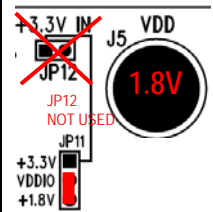
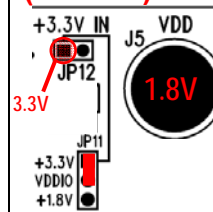
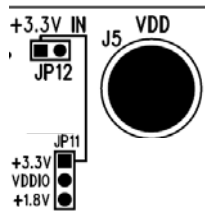
Reference	Description	+1.8V VDDIO	+3.3V VDDIO	JP11
JP11	VDDIO LVCMOS I/O level configuration.	VDDIO = 1.8V  1.8V LVCMOS inputs	VDDIO = 3.3V (Default)  apply external 3.3V LVCMOS inputs	



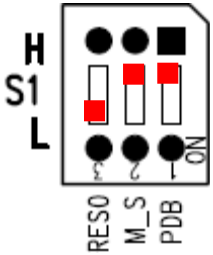

S1: Serializer Input Features Selection

Reference	Description	Input = L	Input = H	S1
MODE (M_S)	I2C Master / Slave select	Master	Slave (Default)	
PDB	PowerDown Bar	Powers Down	Operational (Default)	
RES 0 <i>(* IMPORTANT See user note below)</i>	Reserved	MUST be tied low for normal operation (Default)		

*Note:

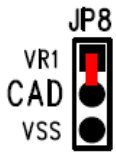
In user layout RES0 **MUST** be tied low for proper operation.

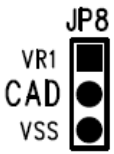
JP8,VR1: Address Decoder

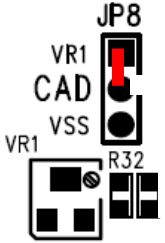
Reference	Description	Setting		Connector
JP8	DS90UB903Q I2C Device ID Address Selection Default address: 0xB0'h	Enabled – With jumper	VSS – Default address (Default)	
				
JP8 & VR1	R _{ID} value adjustment (via screw) JP8 MUST have a jumper to use VR1 potentiometer. VR1 = 0Ω to 100KΩ	Clockwise	Counter- Clockwise	
		 Decreases R _{ID} value	 Increases R _{ID} value	

The ID[x] (CAD) pin is used to set the physical slave address of the DS90UB903Q (I2C only) to allow up to six devices on the bus using only a single pin. The Address Decoder employs a 10 kΩ pull up resistor to +1.8V and a variable potentiometer (VR1) for the pull down resistor R_{ID} to GND to generate six unique values based on the table below. Once the address bits are latched on power up, the device will keep the slave address until a power down or reset condition occurs.

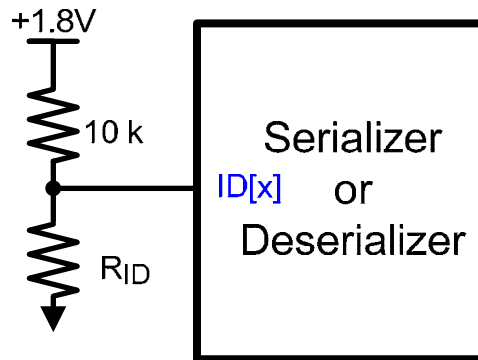
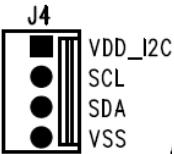



Figure 3. ID[x] Pin Connection Diagram







Table 1. ID[x] Resistor Value – DS90UB903Q Slave Address

Rid Resistor Ω	Address 7'b	Address 8'b 0 appended (WRITE)
0	7b' 101 1000 (h'58)	8b' 1011 0000 (h'B0)
2.0K	7b' 101 1001 (h'59)	8b' 1011 0010 (h'B2)
4.7K	7b' 101 1010 (h'5A)	8b' 1011 0100 (h'B4)
8.2K	7b' 101 1011 (h'5B)	8b' 1011 0110 (h'B6)
12.1K	7b' 101 1100 (h'5C)	8b' 1011 1000 (h'B8)
39.0K	7b' 101 1110 (h'5E)	8b' 1011 1100 (h'BC)

Serializer Bidirectional Control Bus (SCL, SDA) – I²C Compliant

Reference	Description	Settings	Connector
J4	I ² C Port	Pinout: 1 – VDD_I2C 2 – SCL 3 – SDA 4 – VSS	
JP9	I ² C Input Port	Closed: VDD_I2C power is applied through the VDDIO source with onboard 1.0Kohm pull up resistors (Default)	
		Open: VDD_I2C power is applied externally Note: when connecting the bus externally, the target source must have external pull up resistor.	

JP6, JP7: USB Red and Black wire

Reference	Description	VDD	VSS	OPEN
JP6	Power wire in USB cable thru P2 (and P3 not mounted) connector Jumper RED to VSS – recommended <i>Note: Normally VDD in USB application</i>	Red wire tied to VDD 	Red wire tied to VSS (Default) 	Red wire floating (not recommended) 
JP7	Power wire in USB cable thru P2 (and P3 not mounted) connector Jumper BLACK to VSS – recommended <i>Note: Normally VSS in USB application</i>	Black wire tied to VDD 	Black wire tied to VSS (Default) 	Black wire floating (not recommended) 

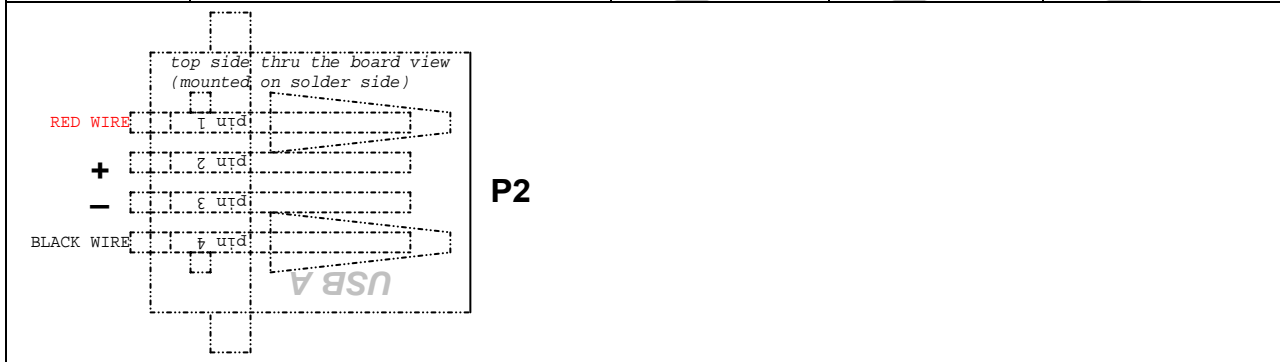

Serializer LVCMOS and FPD-Link III Pinout by Connector

The following three tables illustrate how the Serializer connections mapped to the IDC connector J1, the FPD-Link III I/O on the USB-A connector P2, and the mini USB P3 (not mounted) pinouts. Note – labels are also printed on the demo boards for both the LVCMOS inputs/outputs and FPD-Link III I/Os.

J1			
LVCMOS I/O			
pin no.	name	name	pin no.
1	GND	DIN0	2
3	GND	DIN1	4
5	GND	DIN2	6
7	GND	DIN3	8
9	GND	DIN4	10
11	GND	DIN5	12
13	GND	DIN6	14
15	GND	DIN7	16
17	GND	DIN8	18
19	GND	DIN9	20
21	GND	DIN10	22
23	GND	DIN11	24
25	GND	DIN12	26
27	GND	DIN13	28
29	GND	DIN14	30
31	GND	DIN15	32
33	GND	DIN16	34
35	GND	DIN17	36
37	GND	DIN18	38
39	GND	DIN19	40
41	GND	DIN20	42
43	GND	PCLK	44

P2	
(bottom side)	
FPD-Link III	
pin no.	name
1	JP6
2	DOUT+
3	DOUT-
4	JP7

P3	
(topside)	
(not mounted)	
FPD-Link III	
pin no.	name
5	JP6
4	NC
3	DOUT-
2	DOUT+
1	JP7

DS9UB904Q Deserializer Board Description:

The USB connector J2 (mini USB) on the topside of the board provides the interface connection for FPD-Link III signals to the Serializer board. Note: J5 (mini USB) on the bottom side is un-stuffed and not used with the cable provided in the kit.

The Deserializer board is powered externally from the J8 (VDD) and J9 (VSS) connectors shown below. For the Deserializer to be operational, the S1 switch – PDB must be set HIGH. S1-RES0, BISTEN (Normal mode) must be set LOW. Master or slave mode is user selected on S1-M_S (MODE).

The 2x22 pin IDC Connector J7 provides access to the 21 bit 1.8V or 3.3V LVCMOS and PCLK clock outputs.

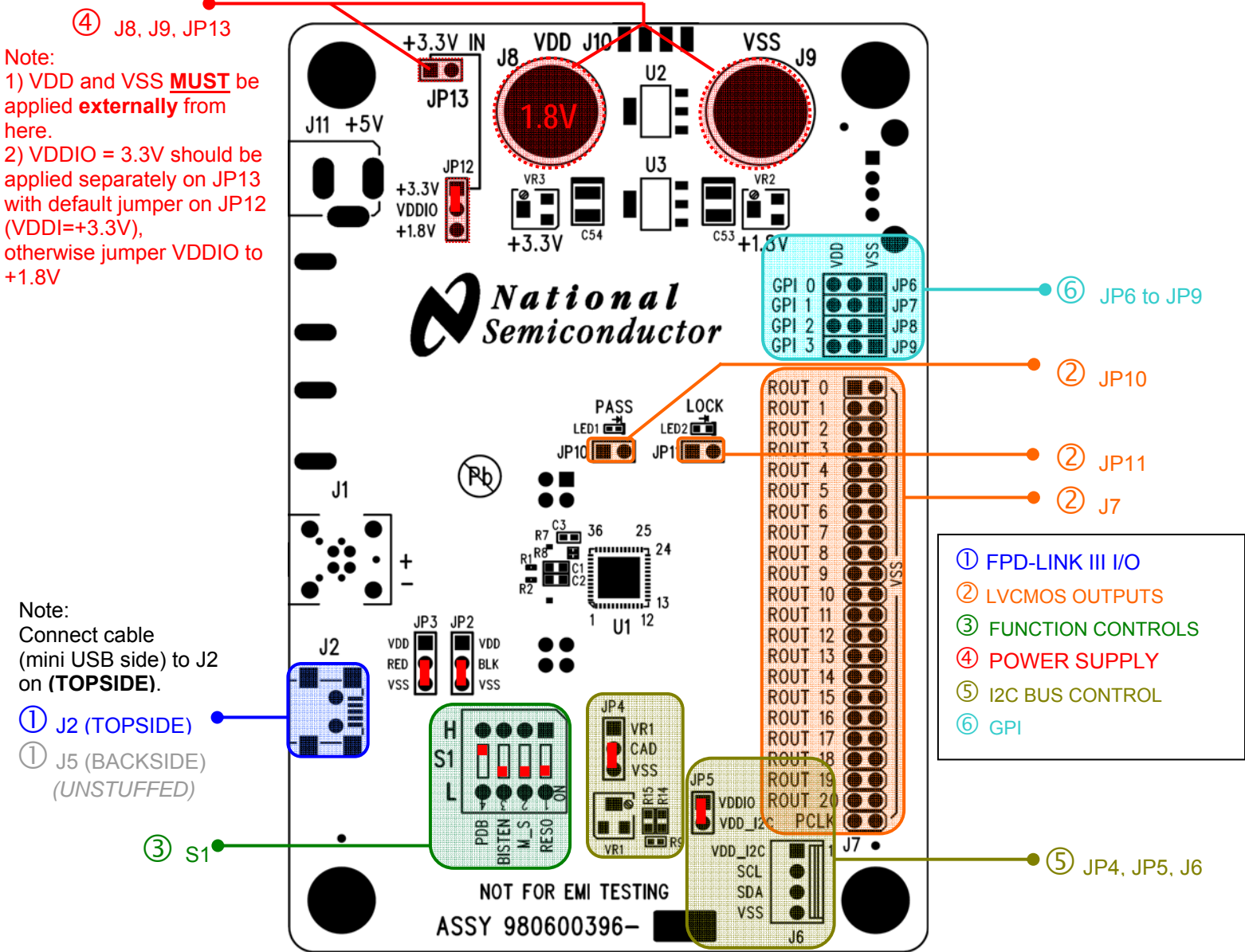

Configuration Settings for the Deserializer Demo Board

VDDIO: 1.8V or 3.3V LVCMOS INPUT/OUTPUT SELECTION

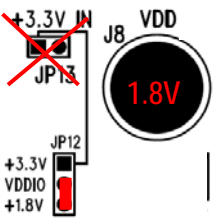
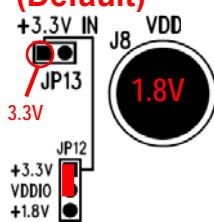
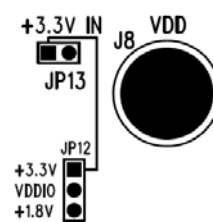

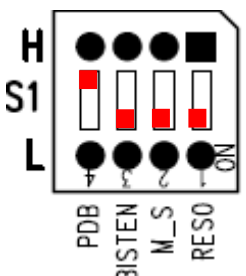

Reference	Description	+1.8V VDDIO	+3.3V VDDIO	JP12
JP12	VDDIO LVCMOS I/O level configuration.	<p>VDDIO = 1.8V</p>  <p>1.8V LVCMOS</p>	<p>VDDIO = 3.3V (Default)</p>  <p>apply external 3.3V LVCMOS</p>	

S1: Deserializer Input Features Selection

Reference	Description	Input = L	Input = H	S1
PDB	PowerDown Bar	Power Down (Disabled)	Operational (Default)	
BISTEN	BIST Enable Pin	Normal operating mode. BIST is disabled. (Default)	BIST Mode is enabled.	
M_S (MODE)	I2C Master / Slave select	Master (Default)	Slave	
RES 0 (* IMPORTANT See user note below)	Reserved	MUST be tied low for normal operation (Default)		

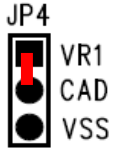
*Note: In user layout RES0 **MUST** be tied low for proper operation.

JP4,VR1: Address Decoder

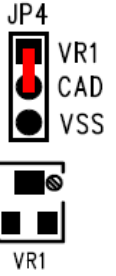

Reference	Description	Setting		Connector
JP4	DS90UB904Q I2C Device ID Address Selection Default address: 0xC0'h	Enabled – With jumper 	VSS – Default address (Default) 	
JP4 & VR1	R _{ID} value adjustment (via screw) JP4 MUST have a jumper to use VR1 potentiometer. VR1 = 0Ω to 100KΩ	Clockwise  Decreases R _{ID} value	Counter-Clockwise  Increases R _{ID} value	

The ID[x] (CAD) pin is used to set the slave address of the DS90UB904Q (I2C only) to allow up to six devices on the bus using only a single pin. The Address Decoder employs a 10 kΩ pull up resistor to VDD 1.8V and a variable potentiometer (VR1) pull down resistor R_{ID} to generate six unique values based on the table below. Once the address bits are latched on power up, the device will keep the slave address until a power down or reset condition occurs.





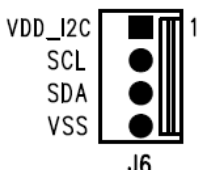

Table 2. ID[x] Resistor Value – DS90UB904Q Slave Address

Rid Resistor Ω	Address 7'b	Address 8'b 0 appended (WRITE)
0	7b' 110 0000 (h'60)	8b' 1100 0000 (h'C0)
2.0K	7b' 110 0001 (h'61)	8b' 1100 0010 (h'C2)
4.7K	7b' 110 0010 (h'62)	8b' 1100 0100 (h'C4)
8.2K	7b' 110 0011 (h'62)	8b' 1101 0110 (h'C6)
12.1K	7b' 110 0100 (h'62)	8b' 1101 1000 (h'C8)
39.0K	7b' 110 0110 (h'66)	8b' 1100 1100 (h'CC)







Deserializer Bidirectional Control Bus (SCL, SDA) - I2C Compliant

Reference	Description	Settings	Connector
J6	I2C Port	Pinout: 1 – VDD_I2C 2 – SCL 3 – SDA 4 – VSS	
JP5	I2C Input Port	Closed: VDD_I2C power is applied through the VDDIO source with onboard 1.0Kohm pull up resistors (Default)	
		Open: VDD_I2C power is applied externally Note: when connecting the bus externally, the target source must have external pull up resistor.	







JP11: Output Lock Monitor

Reference	Description	Output = L	Output = H	JP11
LOCK	Receiver PLL LOCK Note: DO NOT SHORT JUMPER IN JP11.	Unlocked LOCK LED2  JP11 	Locked LOCK LED2  JP11 	LOCK LED2  JP11 

JP10: Output Pass Monitor

Reference	Description	Output = L	Output = H	JP10
PASS	PASS (BIST mode) Note: DO NOT SHORT JUMPER IN JP10.	ERROR PASS LED1  JP10 	PASS PASS LED1  JP10 	PASS PASS LED1  JP10 

JP3, JP2: USB Red and Black wire

Reference	Description	VDD	VSS	OPEN
JP3	Power wire in USB cable thru J2 (<i>and J5 not mounted</i>) connector Jumper RED to VSS – recommended <i>Note: Normally VDD in USB application</i>	Red wire tied to VDD 	Red wire tied to VSS (Default) 	Red wire floating (not recommended) 
JP2	Power wire in USB cable thru J2 (<i>and J5 not mounted</i>) connector Jumper BLACK to VSS – recommended <i>Note: Normally VSS in USB application</i>	Black wire tied to VDD 	Black wire tied to VSS (Default) 	Black wire floating (not recommended) 

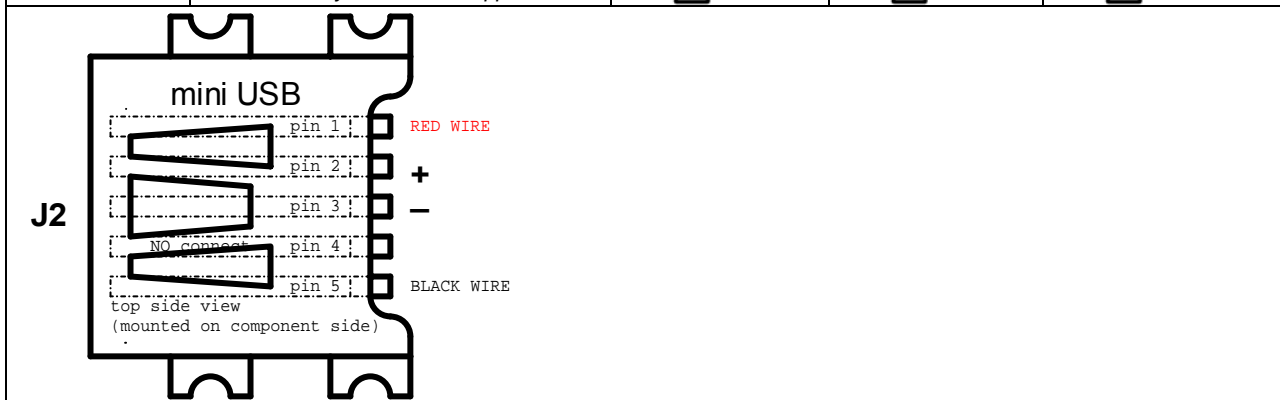

Deserializer FPD-Link III Pinout and LVCMOS by Connector

The following three tables illustrate how the Deserializer connections mapped to the IDC connector J7, the mini USB connector J2, and the mini USB connector J5 pinouts. Note – labels are also printed on the demo boards for both the FPD-Link III I/O and LVCMOS inputs/outputs.

J7			
LVCMOS I/O			
pin no.	name	name	pin no.
1	ROUT0	GND	2
3	ROUT1	GND	4
5	ROUT2	GND	6
7	ROUT3	GND	8
9	ROUT4	GND	10
11	ROUT5	GND	12
13	ROUT6	GND	14
15	ROUT7	GND	16
17	ROUT8	GND	18
19	ROUT9	GND	20
21	ROUT10	GND	22
23	ROUT11	GND	24
25	ROUT12	GND	26
27	ROUT13	GND	28
29	ROUT14	GND	30
31	ROUT15	GND	32
33	ROUT16	GND	34
35	ROUT17	GND	36
37	ROUT18	GND	38
39	ROUT19	GND	40
41	ROUT20	GND	42
43	PCLK	GND	44

J2	
(topside)	
FPD-Link III	
pin no.	name
1	JP3
2	RIN+
3	RIN-
4	NC
5	JP2

J5	
(bottom side)	
(not mounted)	
FPD-Link III	
pin no.	name
5	JP3
4	NC
3	RIN-
2	RIN+
1	JP2

Typical Connection and Test Equipment

The following is a list of typical test equipment that may be used to generate signals for the Serializer inputs:

- 1) Digital Video Source – for generation of specific display timing such as a Graphics Controller or CMOS imager with digital video signals (1.8V/3.3V LVCMOS).
- 2) Any other signal generator / video source that generates the correct input levels.

The following is a list of typical test equipment that may be used to monitor the output signals from the Deserializer:

- 1) A display module (such as an LCD)
- 2) Controller or capture card which supports digital video signals (1.8V/3.3V LVCMOS).
- 3) Video capture card
- 4) Microcontroller or FPGA with an I²C interface
- 5) Optional – Logic Analyzer or Oscilloscope
- 6) Any SCOPE with a bandwidth of at least 50MHz for 1.8V/3.3V LVCMOS and/or 1.5GHz for observing differential signals.

Figure 4 below illustrates an application using a MCU/FPGA controller connected to DS90UB903Q with I²C bus and a display module connected to DS90UB904Q with I²C bus. Both MCU/FPGA controller video and control information are transferred on the same serial video link.

Evaluation of the Bi-directional Control Channel

This section describes how to perform I²C instructions between MCU/FPGA and a remote peripheral device through the DS90UB904Q and DS90UB903Q pair configured in a display type of application. Figure 4 shows the configuration of evaluation boards for I²C communication. A MCU/FPGA controller with an I²C interface is required. Refer to the DS90UB903Q/904Q datasheet for the definition of each register.

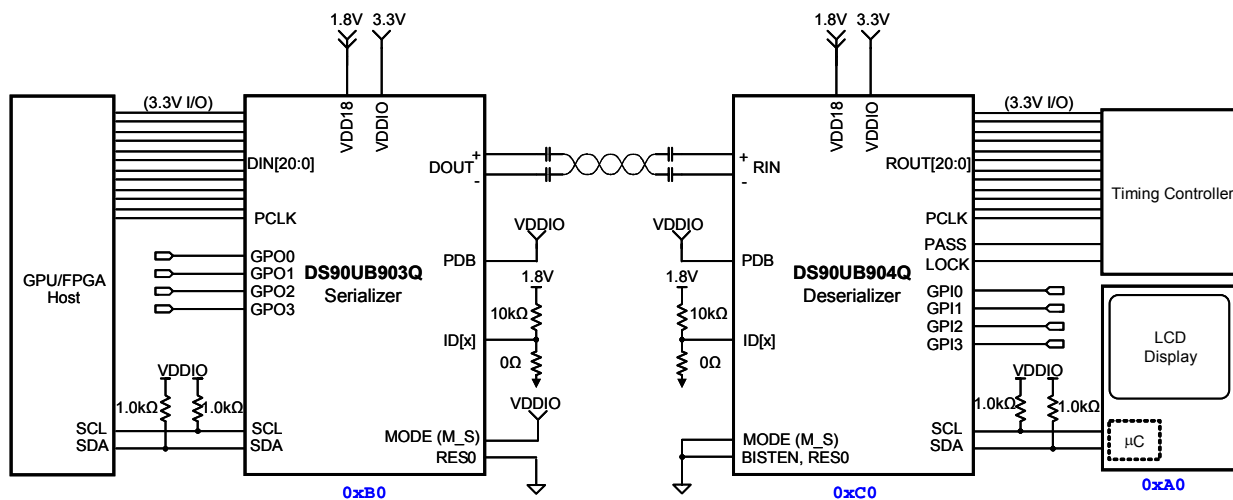

Figure 4. Example of DS90UB903Q/904Q in Display Application

Display Mode:

In Display mode, I²C transactions originate from the controller attached to the Serializer. The I²C slave core in the Serializer will detect if a transaction targets (local) registers within the Serializer or the (remote) registers within the Deserializer or a remote slave connected to the I²C master interface of the Deserializer. Commands are sent over the forward channel link to initiate the transactions. The Deserializer will receive the command and generate an I²C transaction on its local I²C bus. At the same time, the Deserializer will capture the response on the I²C bus and return the response as a command on the bi-directional control channel. The Serializer parses the response and passes the appropriate response to the Serializer I²C bus.

Procedure - Display Mode:

- 1) Connect the 1.8V and 3.3V power with +1.8V and +3.3V supplies accordingly. Keep the power off.
- 2) Verify that all the jumper positions and switches are correctly set (as per default positions defined in “Configuration Settings for the Serializer/Deserializer Demo Board” tables).
- 3) Connect the USB interface cable between P2 (DS90UB903Q board) connector and J2 connector (DS90UB904Q board).
- 4) Set hardware configuration for DS90UB903Q Serializer and DS90UB904Q Deserializer devices
 - a. Verify peripheral device (display) address is set to **0xA0**
 - b. Set to Display mode: Serializer MODE (M_S) pin = H and Deserializer MODE (M_S) pin = L
 - c. Set Serializer and Deserializer I²C slave address on ID[x] (CAD) pin:
 - i. Serializer Rid=0ohm; Serializer I²C slave address is **0xB0**
 - ii. Deserializer Rid=0ohm; Deserializer I²C slave address is **0xC0**
- 5) Turn on the +1.8V and +3.3V power supplies
- 6) Before initiating any I²C commands, the Serializer needs to be programmed with the target slave device address and Deserializer device address. DES_DEV_ID Register 0x06h sets the Deserializer device address and SLAVE_DEV_ID register 0x7h sets the remote target slave address. If the I²C slave address matches any of registers values, the I²C slave will hold the transaction allowing read or write to target device. Note: In Display mode operation, registers 0x08h~0x17h on Deserializer must be reset to 0x00.
- 7) Execute I²C instructions to write the following registers
 - a. DS90UB903Q Serializer (**0xB0**)
 - i. Write 0xA0 (Slave Address) to Register 0x07 of Serializer (**0xB0**)
 - ii. Write 0xC0 (Deserializer Address) to Register 0x06 of Serializer (**0xB0**) (0xC0 is written by default upon power cycling on PDB)
- 8) Verify that LOCK LED2 on the Deserializer board is lit; This indicates the chipset is Locked
- 9) After initialization, the PCLK clock and input data can begin transmission to the Serializer. The Serializer locks onto PCLK input (if present) otherwise the on-chip oscillator (25 MHz) is used as the input clock source. Note the user should monitor the LOCK pin and confirm LOCK = H before performing any I²C communication across the link.

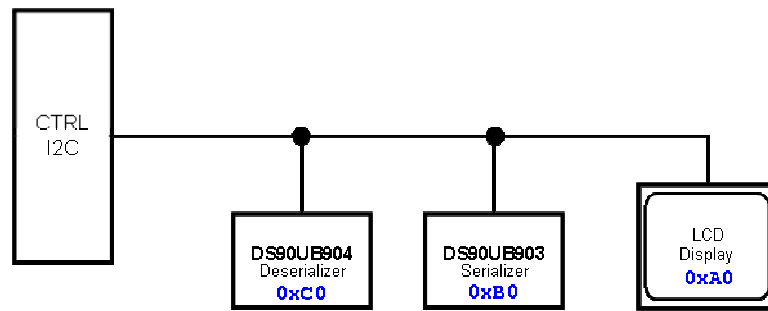

Figure 5. Virtual device addressing from GPU/FPGA I2C controller

I²C Communication over Bi-directional Control Channel in Display Mode

This section provides instructions for a simple I²C Read/Write transaction over the bi-directional control channel validating the interface between the host and Serializer to Deserializer.

- 1) Check the Serializer DES DEV ID register 0x06 contents
- 2) The value entered in Serializer register 0x06 sets the target Deserializer device to communicate with. Load the Deserializer slave address register.
- 3) Host controller to load and transmit data byte to Deserializer address 0xC0
- 4) For verification purposes Deserializer register 0x13 General-purpose register will be exercised for reading and writing data. Other Deserializer registers can be programmed to check internal functions; such as register 0x03 b[0] RRFB.
- 5) Host controller to load and transmit write transaction to register byte 0x13 = 0xFF. Note default of register 0x13 = 0x00.
- 6) Host controller to read back Deserializer 0xC0 register 0x13 = 0xFF

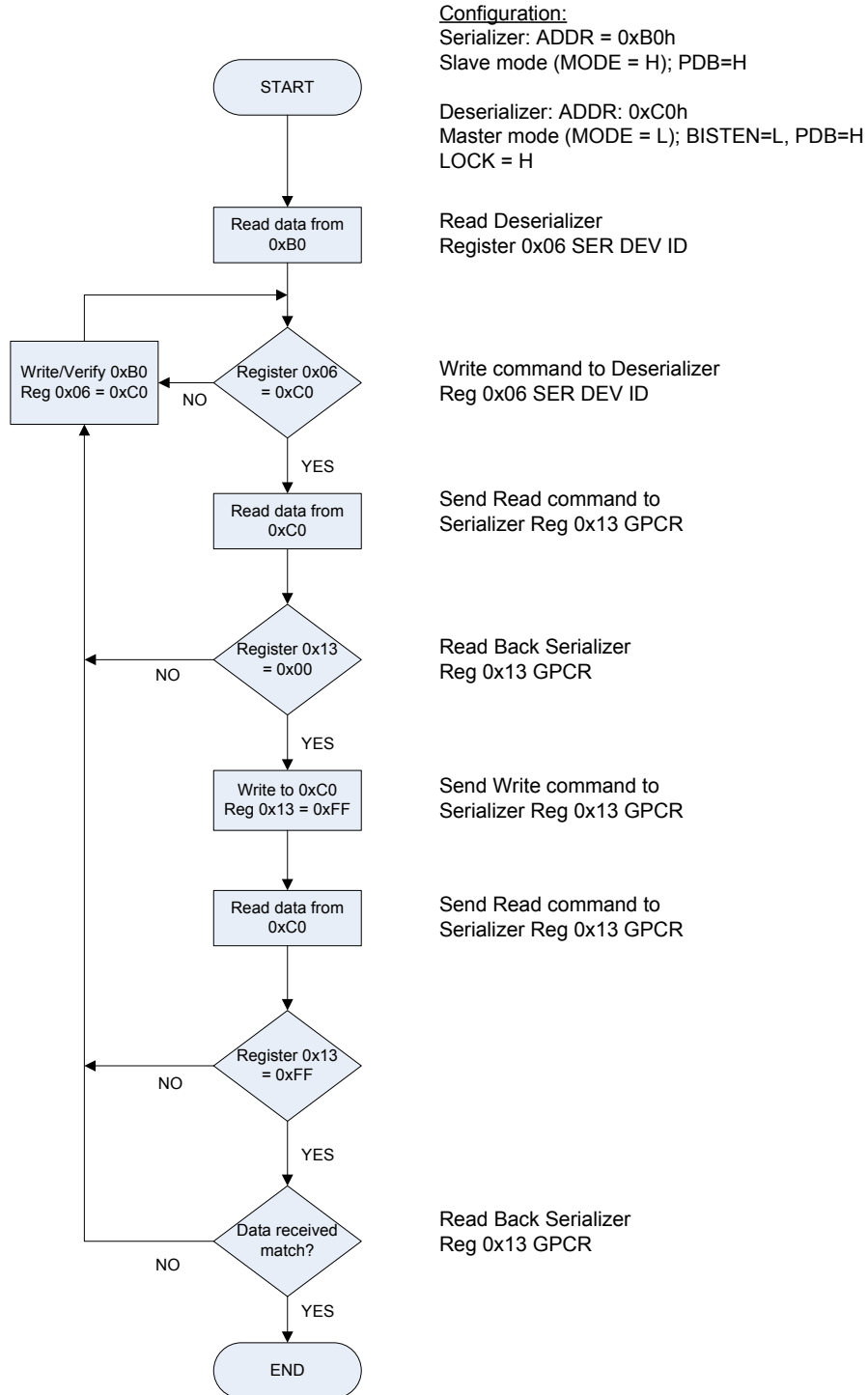

Figure 5. Bi-directional Control Channel Communication Flowchart in Display Mode

Camera Mode:

In Camera mode, I²C transactions originate from the Master controller at the Deserializer side. The I²C slave core in the Deserializer will detect if a transaction is intended for the Serializer or a slave at the Serializer. Commands are sent over the bi-directional control channel to initiate the transactions. The Serializer will receive the command and generate an I²C transaction on its local I²C bus. At the same time, the Serializer will capture the response on the I²C bus and return the response on the forward channel link. The Deserializer parses the response and passes the appropriate response to the Deserializer I²C bus.

Note: The default settings for this EVK are shipped with a display mode configuration, but this EVK also supports a camera mode. This mode is suitable for setups where a camera is connected to the DS90UB903Q Serializer end and a host controller is connected to the DS90UB904Q Deserializer end. The I²C Master would need to be connected to the DS90UB904Q Deserializer end. A typical setup for camera mode is shown below:

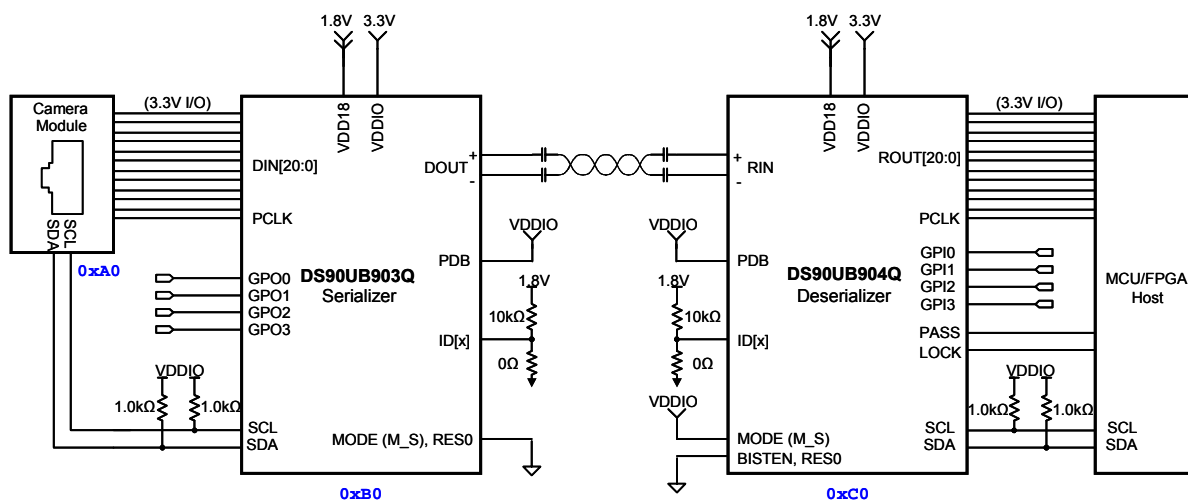
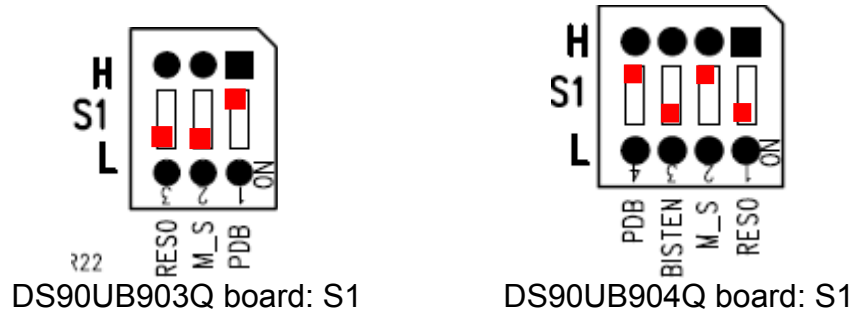

Figure 6. Example of DS90UB903Q/904Q in Camera Application

Procedure – Camera Mode:

- 1) Connect the 1.8V and 3.3V power with +1.8V and +3.3V supplies accordingly. Keep the power off.
- 2) Verify that all the jumper positions and switches are correctly set.
NOTE: For Camera Mode, the default settings for switch S1-M_S on S1 for the DS90UB903Q Serializer and DS90UB904Q Deserializer boards must be reversed.



- 3) Connect the USB interface cable between P2 (DS90UB903Q board) connector and J2 connector (DS90UB904Q board). Note that hot-plugging assertion of cable between Serializer and Deserializer is not supported.
- 4) Set hardware configuration for DS90UB903Q Serializer and DS90UB904Q Deserializer devices
 - a. Verify peripheral device (camera) address is set to **0xA0**
 - b. Set to Camera mode: Serializer MODE (M_S) pin = L and Deserializer MODE (M_S) pin = H
 - c. Set Serializer and Deserializer I²C slave address on ID[x] (CAD) pin:
 - iii. Serializer Rid=0ohm; Serializer I²C slave address is **0xB0**
 - iv. Deserializer Rid=0ohm; Deserializer I²C slave address is **0xC0**
- 5) Turn on the +1.8V and +3.3V power supplies
- 6) The DS90UB904Q Deserializer I²C slave is enabled to receive data directly from the I²C Master Controller. I²C transfers are processed in a one byte basis. After receiving one byte, the Deserializer slave will need to acknowledge (ACK) the transfer to receive the next following byte. The Deserializer slave holds SCL low (clock stretch) for the required period until an ACK (or NACK) is established and then releases it. The Deserializer I²C slave acknowledges all the transfers addressed to Deserializer, Serializer, or remote device.
- 7) Before initiating any I²C commands, the Deserializer needs to be programmed with the target slave device addresses and Serializer device address. SER_DEV_ID Register 0x07h sets the Serializer device address and SLAVE_x_MATCH/SLAVE_x_INDEX registers 0x08h~0x17h set the remote target slave addresses. In

slave mode the address register is compared with the address byte sent by the I²C master. If the addresses are equal to any of registers values, the I²C slave will acknowledge and hold the bus to propagate the transaction to the target device otherwise it returns no acknowledge.

- 8) Execute I²C instructions to write the following registers
 - a. Assign ID Match values for camera address on Deserializer
 - i. Write 0xA0 to Register 0x08 of Deserializer (0xC0)
 - ii. Write 0xA0 to Register 0x10 of Deserializer (0xC0)
 - b. Wake up the Serializer by programming the 'Remote Wakeup' Register on the Deserializer
 - i. Write 0x04 to Register 0x01 of Deserializer (0xC0)
- 9) Verify that LOCK LED2 on the Deserializer board is lit; This indicates the chipset is Locked
- 10) After initialization, the camera PCLK clock and input data can begin transmission to the Serializer. The Serializer locks onto PCLK input (if present) otherwise the on-chip oscillator (25 MHz) is used as the input clock source. Note the MCU controller should monitor the LOCK pin and confirm LOCK = H before performing any I²C communication across the link.

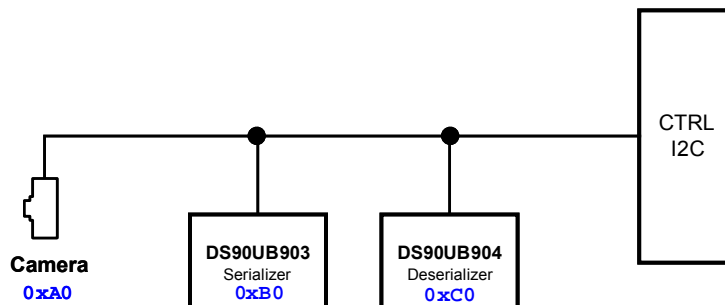

Figure 7. Virtual device addressing from MCU/FPGA I²C controller

I²C Communication over Bi-directional Control Channel in Camera Mode

This section provides instructions for a simple I²C Read/Write transaction over the bi-directional control channel validating the interface between the host and Deserializer to Serializer.

- 1) Check the Deserializer SER DEV ID register 0x07 contents
- 2) The value entered in Deserializer register 0x07 sets the target Serializer device to communicate with. Load the Serializer slave address register.
- 3) Host controller to load and transmit data byte to Serializer address 0xB0
- 4) For verification purposes Serializer register 0x13 General-purpose register will be exercised for reading and writing data. Other Serializer registers can be programmed to check internal functions; such as register 0x03 b[0] TRFB.
- 5) Host controller to load and transmit write transaction to register byte 0x13 = 0xFF. Note default of register 0x13 = 0x00.
- 6) Host controller to read back Serializer 0xB0 register 0x13 = 0xFF

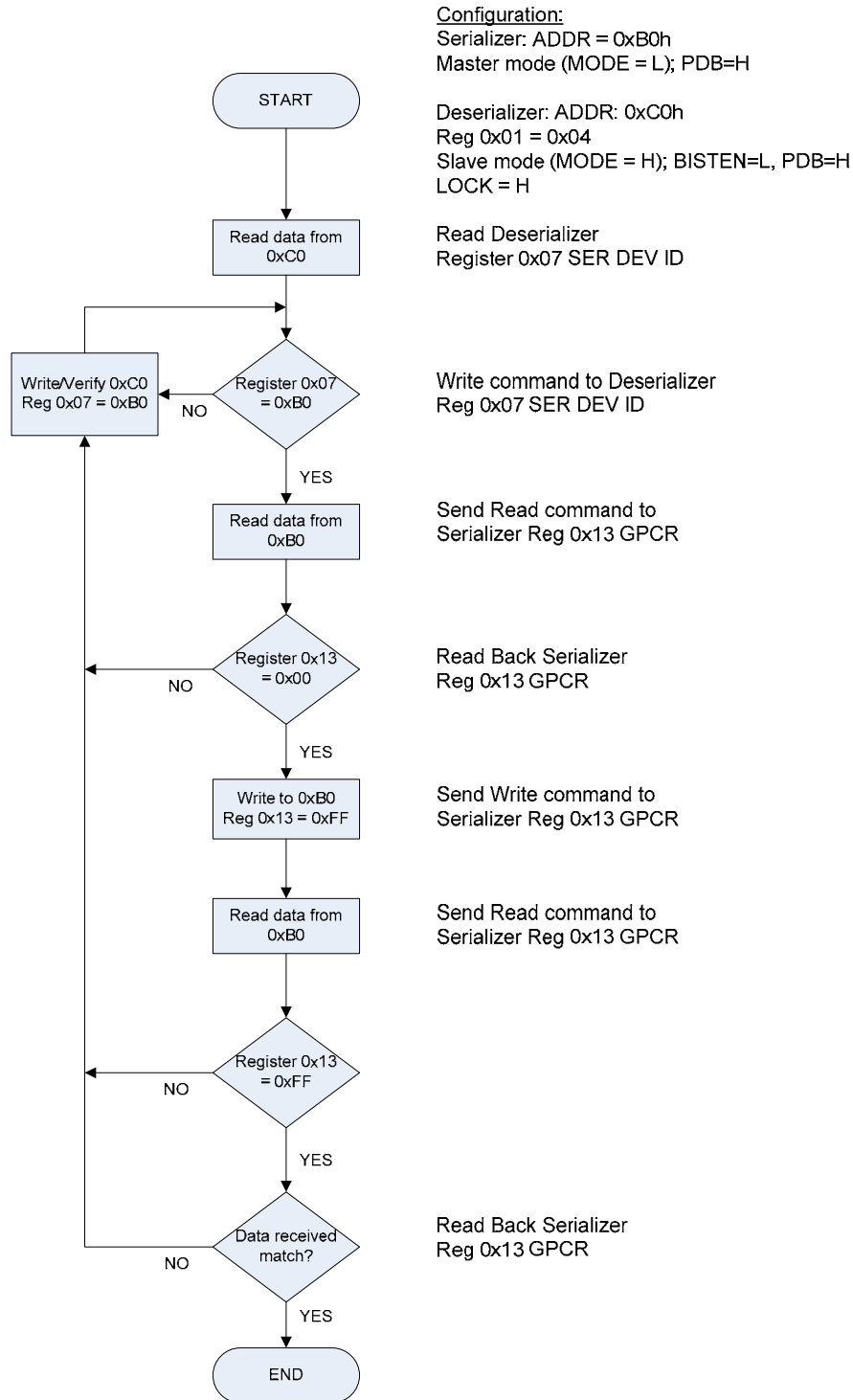

Figure 7. Bi-directional Control Channel Flowchart in Camera Mode

Troubleshooting Demo Setup

NOTE: The DS9UB903Q and DS9UB904Q are NOT USB compliant and should not be plugged into a USB device nor should a USB device be plugged into the demo boards.

If the demo boards are not performing properly, use the following as a guide for quick solutions to potential problems. If the problem persists, please contact the local Sales Representative for assistance.

QUICK CHECKS:

1. Check that Powers and Grounds are connected to both Serializer and Deserializer boards.
2. Check the supply voltage (typical 1.8V) and also current draw with both Serializer and Deserializer boards. The Serializer board should draw about 70mA with clock and all data bits switching at 43 MHz. The Deserializer board should draw about 100mA with clock and all data bits switching at 43 MHz.
3. Verify input clock and input data signals meet requirements (VIL, VIH, tset, thold), Also verify that data is strobed on the selected rising/falling (RFB register) edge of the clock.
4. Check that the Jumpers and Switches are set correctly.
5. Check that the cable is properly connected.

TROUBLESHOOTING CHART

Problem...	Solution...
There is only the output clock.	Make sure the data is applied to the correct input pin.
There is no output data.	Make sure data is valid at the input.
No output data and clock.	Make sure Power is on. Input data and clock are active and connected correctly. Make sure that the cable is secured to both demo boards.
Power, ground, input data and input clock are connected correctly, but no outputs.	Check the Power Down pins of both Serializer and Deserializer boards to make sure that the devices are enabled (PDB=Vdd) for operation.
The devices are pulling more than 1A of current.	Check for shorts in the cables connecting the Serializer and Deserializer boards.
After powering up the demo boards, the power supply reads less than 1.8V when it is set to 1.8V.	Use a larger power supply that will provide enough current for the demo boards, a 500mA minimum power supply is recommended.

Note: Please note that the following references are supplied only as a courtesy to our valued customers. It is not intended to be an endorsement of any particular equipment or supplier.

Cable References

The FPD-Link III interface cable included in the kit is a standard off-the-shelf high-speed USB 2.0 with a 4-pin USB A type on one end and a 5-pin mini USB on the other end and is included for demonstration purposes only.

NOTE: The DS9UB903Q and DS9UB904Q are NOT USB compliant and should not be plugged into a USB device nor should a USB device be plugged into the demo boards.

The inclusion of the USB cable in the kit is for:

- 1) Demonstrating the robustness of the FPD-Link III link over standard twisted pair data cables.
- 2) Readily available and in different lengths without having custom cables made.

- For optimal performance, we recommend Shielded Twisted Pair (STP) 100ohm differential impedance and 24 AWG (or larger diameter) cable for high-speed data applications.

Leoni Dacar 538 series cable:

www.leoni-automotive-cables.com

Rosenberger HSD connector:

www.rosenberger.de/en/Products/35_Automotive_HSD.php

Equipment References

Corelis CAS-1000-I2C/E I2C Bus Analyzer and Exerciser Products:

www.corelis.com/products/I2C-Analyzer.htm

Appendix

Serializer and Deserializer Demo PCB Schematics:

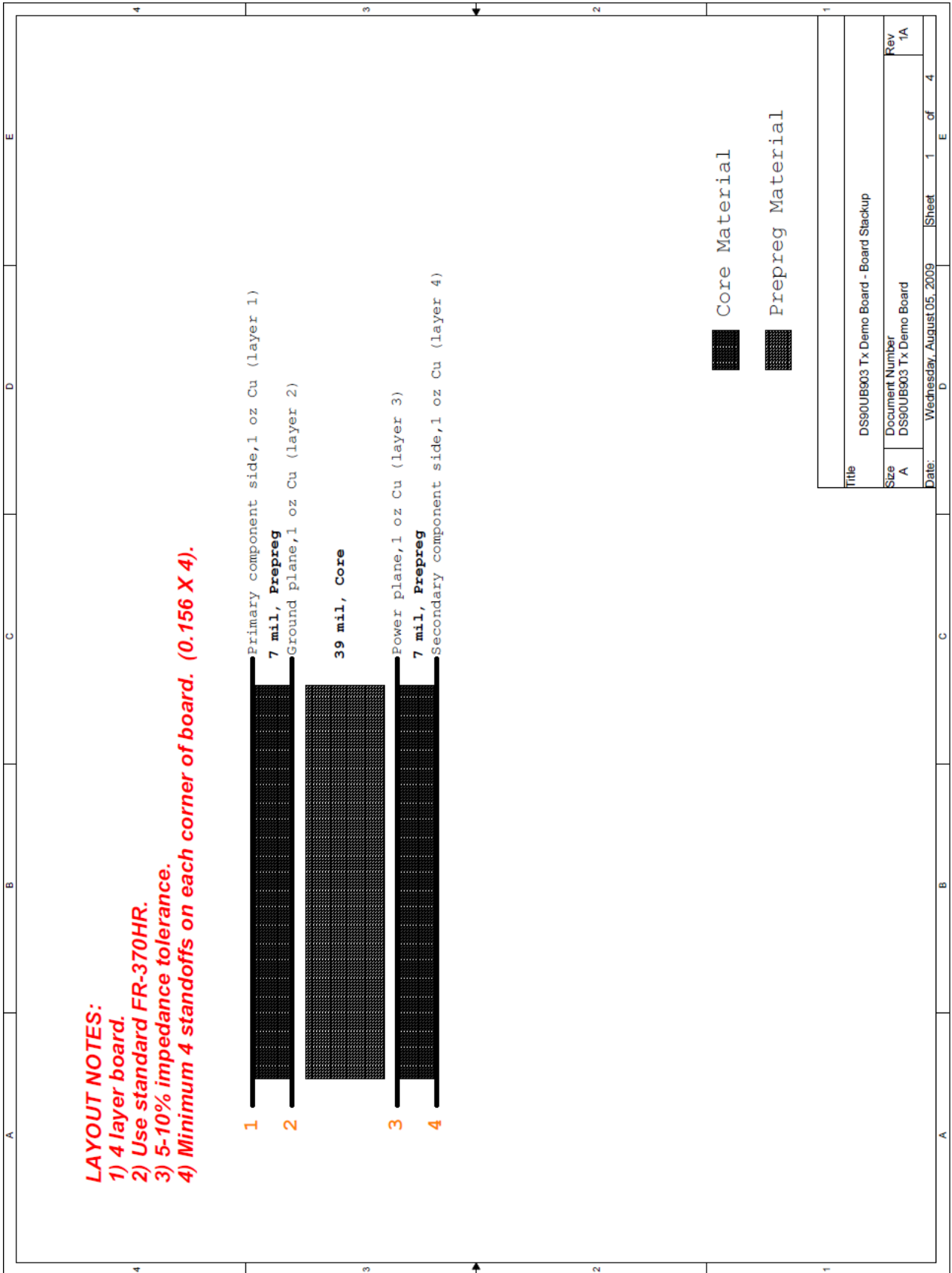

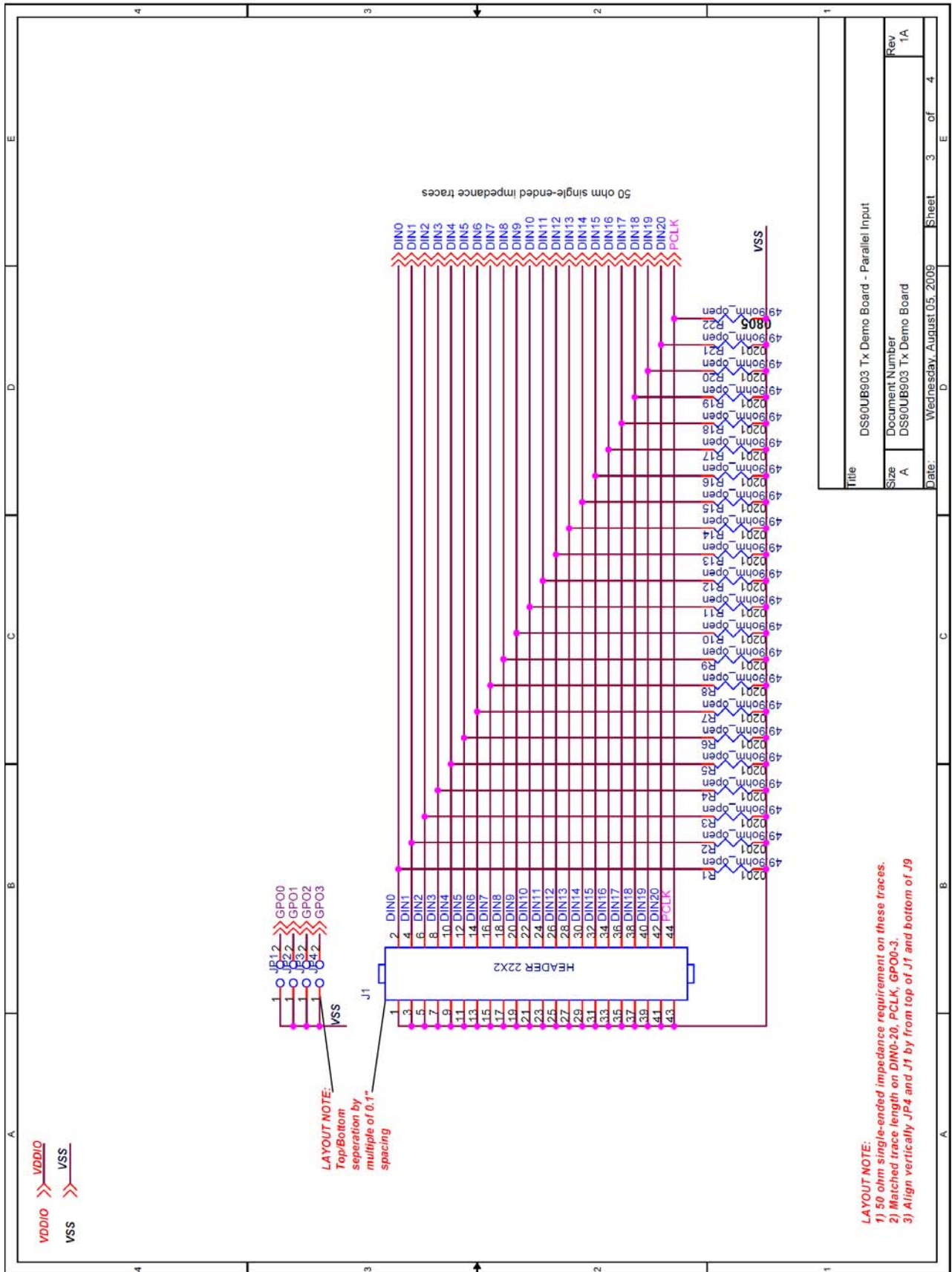

Title		DS90UB903 Tx Demo Board - Parallel Input	
Size	Document Number	Rev	
A	DS90UB903 Tx Demo Board	1A	
Date:	Wednesday, August 05, 2009	Sheet	3 of 4

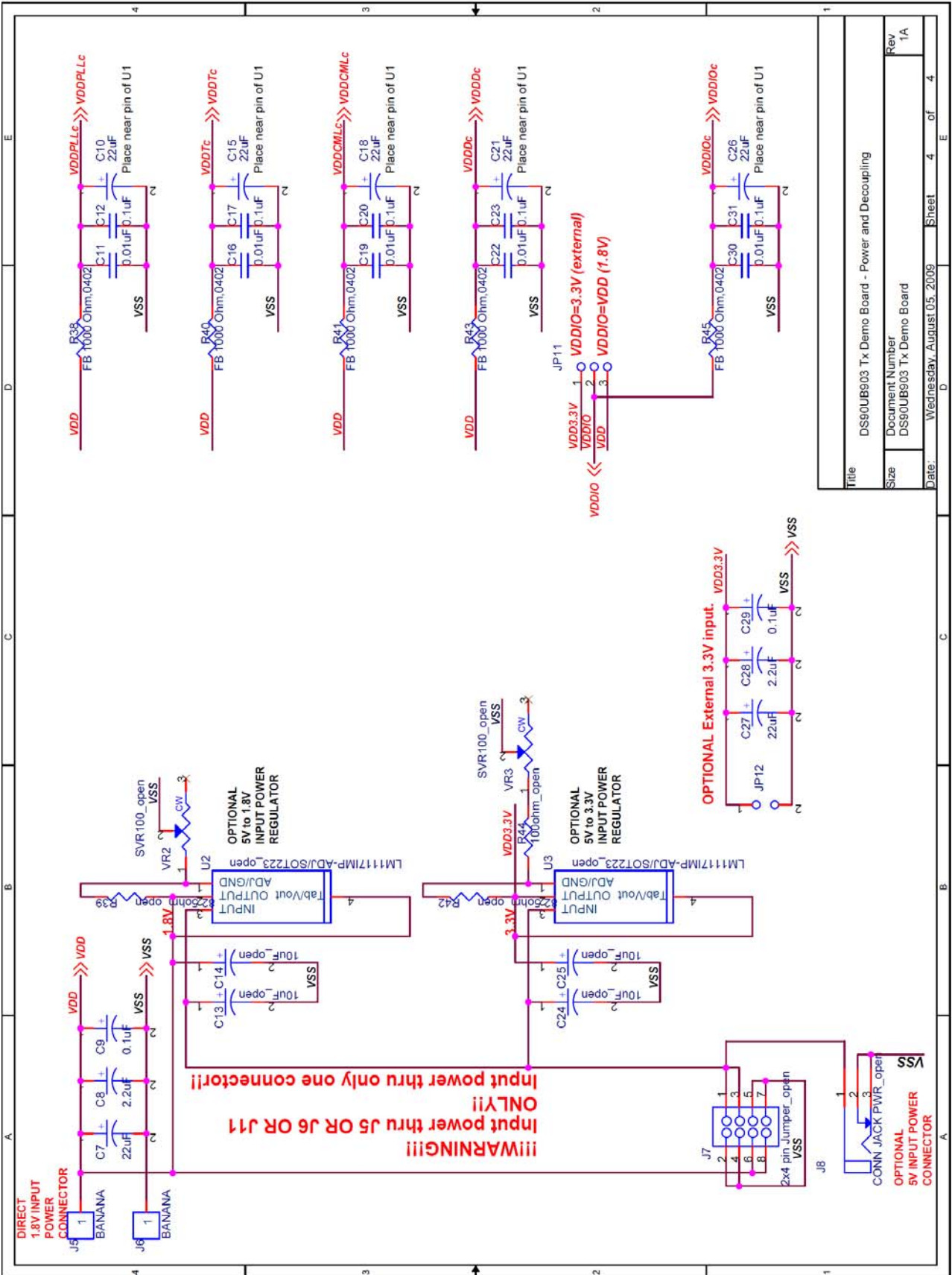

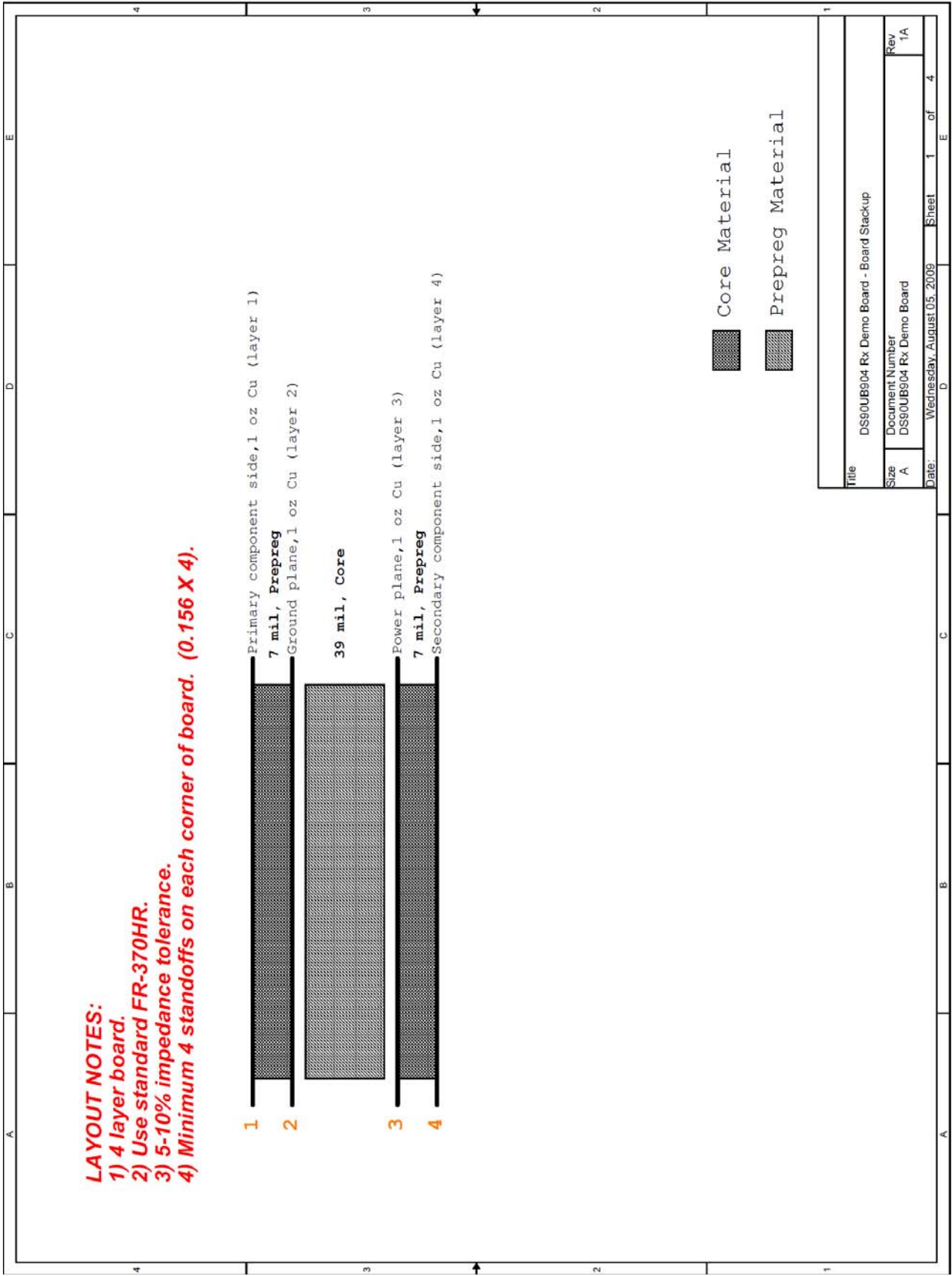

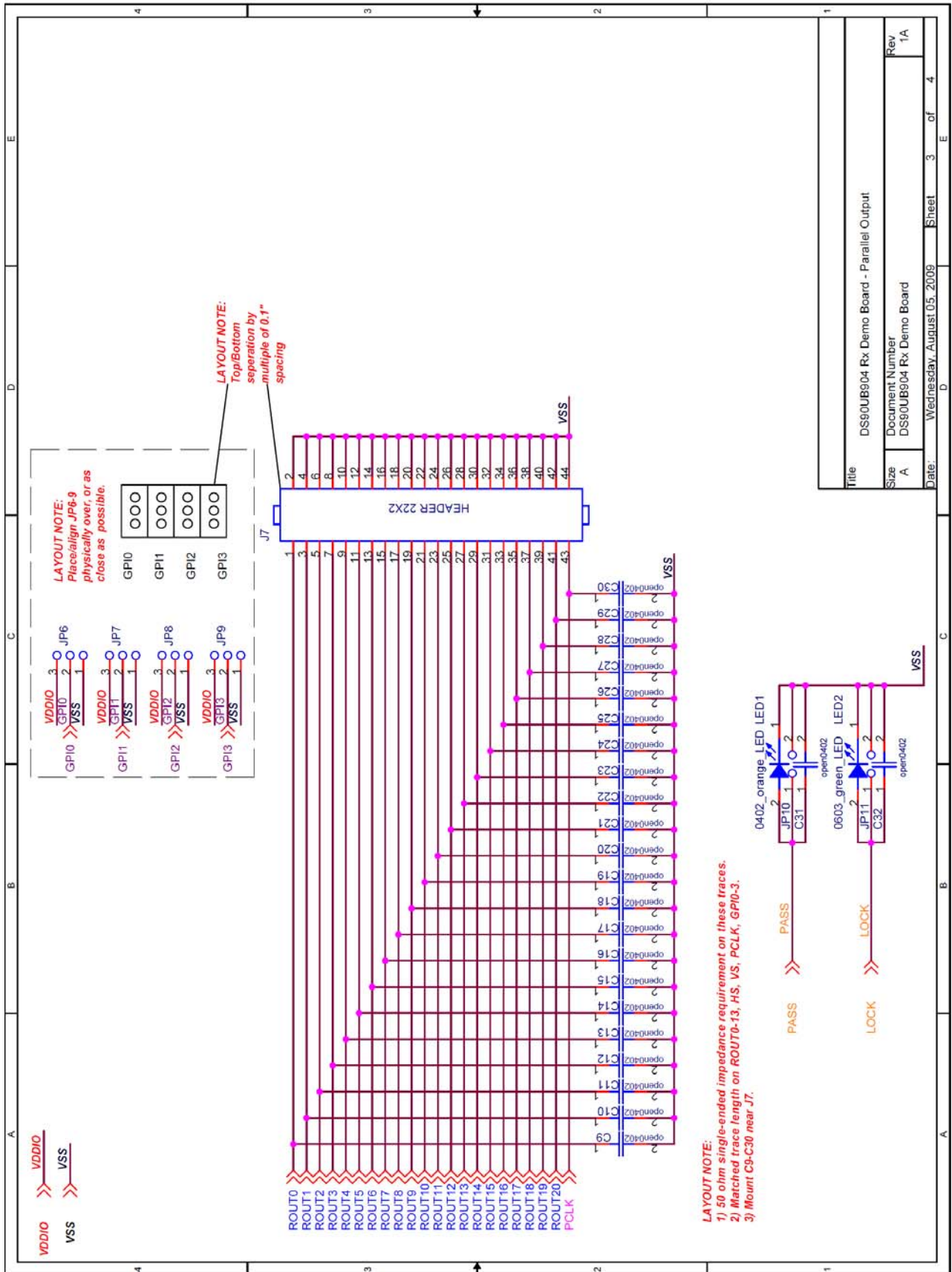

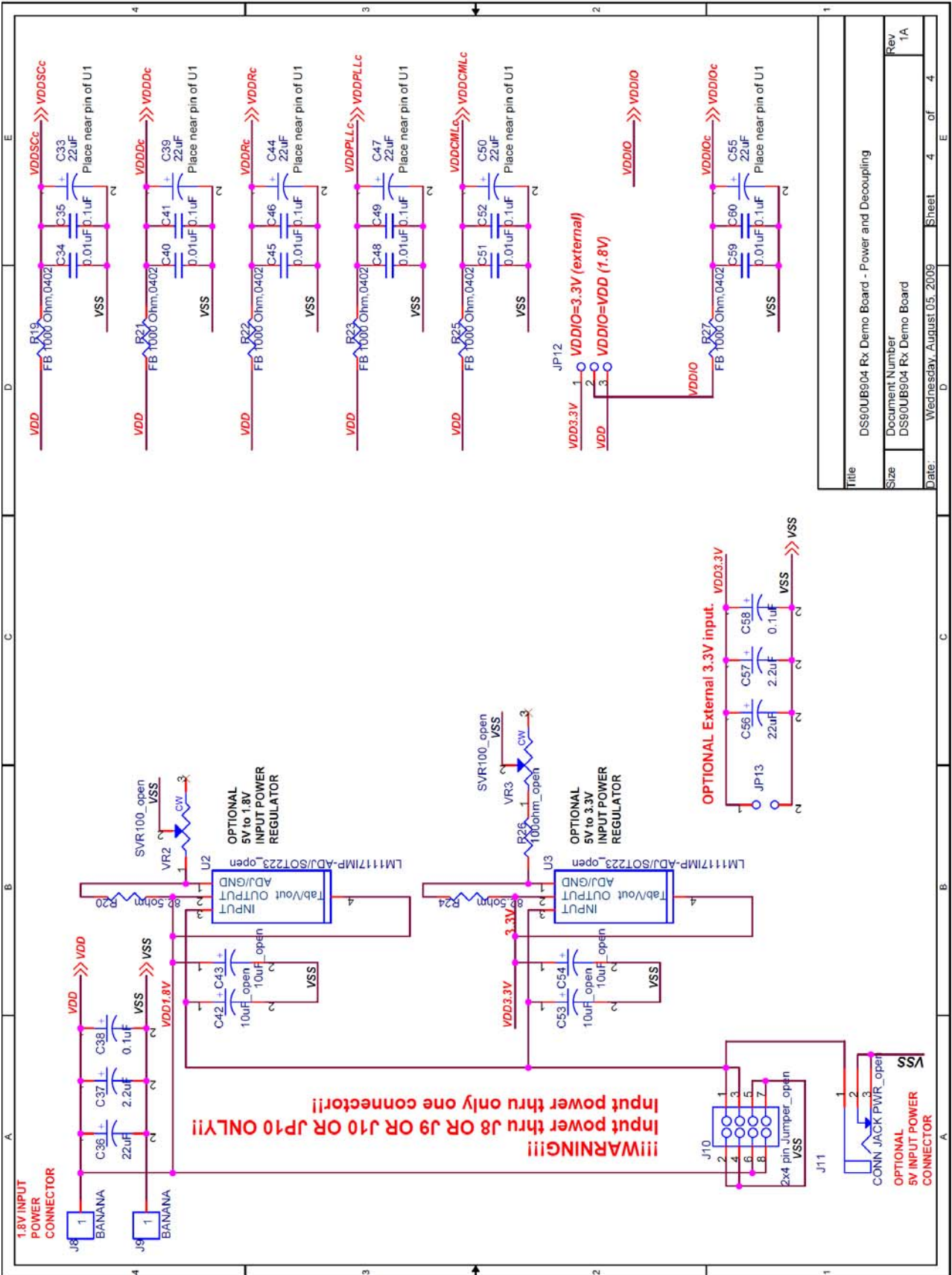

Title		DS90UB904 Rx Demo Board - Power and Decoupling	
Size	Document Number	Rev	1A
Date:		Wednesday, August 05, 2009	Sheet 4 of 4

BOM (Bill of Materials) Serializer Demo PCB:

DS90UB903 Tx Demo Board - Board Stackup Revised: Tuesday, July 27, 2010
 DS90UB903 Tx Demo Board Revision: 1A

Bill Of Materials

Item	Quantity	Reference	Part	PCB Footprint
1	2	C1,C2	0.1uF	CAP/HDC-0603
2	6	C3,C10,C15,C18,C21,C26	22uF	CAP/EIA-B 3528-21
3	2	C5,C4	100pF	CAP/HDC-0201
4	6	C6,C12,C17,C20,C23,C31	0.1uF	CAP/HDC-0603
5	2	C27,C7	22uF	CAP/N
6	2	C28,C8	2.2uF	3528-21_EIA
7	2	C9,C29	0.1uF	CAP/HDC-1206
8	5	C11,C16,C19,C22,C30	0.01uF	CAP/HDC-0603
9	4	C13,C14,C24,C25	10uF_open	CAP/B
10	6	JP1,JP2,JP3,JP4,JP9,JP12	2-Pin Header	Header/2P
11	1	JP5	2X10-Pin Header, open	Header/2X10P
12	5	JP6,JP7,JP8,JP10,JP11	3-Pin Header	Header/3P
13	1	J1	HEADER 22X2	2x22 0.1"
14	2	J3,J2	SMA_open	Edge mount
15	1	J4	IDC1X4	IDC-1x4
16	2	J5,J6	BANANA	CON/BANANA-S
17	1	J7	2x4 pin Jumper_open	IDC_2x4
18	1	J8	CONN JACK PWR_open	3-terminal thru hole power jack
19	1	P1	HSD_2X2_open	CON/HSD-4P
20	1	P2	USB A_open	USB_TYPE_A_4P
21	1	P3	mini USB 5pin_open	mini_B_USB_surface_mount
22	21	R1,R2,R3,R4,R5,R6,R7,R8, R9,R10,R11,R12,R13,R14, R15,R16,R17,R18,R19,R20, R21	49.9ohm_open	RES/HDC-0201
23	1	R22	49.9ohm_open	RES/HDC-0805
24	4	R23,R24,R25,R26	0 ohm_open	RES/HDC-0201
25	1	R27	0 Ohm,0402_open	RES/HDC-0402
26	4	R28,R29,R30,R31	10K	RES/HDC-0603
27	1	R32	100K_open	RES/HDC-0603
28	1	R33	0 Ohm,0402	RES/HDC-0402
29	2	R34,R35	1.0K	RES/HDC-0603
30	2	R36,R37	1K Ohm,0402_open	RES/HDC-0402
31	5	R38,R40,R41,R43,R45	FB 1000 Ohm,0402	RES/HDC-0402
32	2	R42,R39	82.5ohm_open	RES/HDC-0603
33	1	R44	100ohm_open	RES/HDC-0603
34	1	S1	SW DIP-3	DIP-3
35	1	U1	DS90UB903Q	40ld LLP
36	2	U2,U3	LM1117IMP-ADJ/SOT223_open	SOT223
37	1	VR1	SVR100K	Surface Mount
38	2	VR2,VR3	SVR100_open	Surface Mount
39	2	X2,X1	TP_0402	TP/0402
40	1	Y1	OSC4/SM	4 PIN SMT

BOM (Bill of Materials) Deserializer Demo PCB:

DS90UB904 Rx Demo Board - Board Stackup Revised: Tuesday, July 27, 2010
 DS90UB904 Rx Demo Board Revision: 1A

Bill Of Materials

Item	Quantity	Reference	Part	PCB Footprint
1	4	C1,C2,C4,C5	0.1uF	CAP/HDC-0603
2	1	C3	0.1uF_open	CAP/HDC-0402
3	7	C6,C33,C39,C44,C47,C50, C55	22uF	CAP/EIA-B 3528-21
4	2	C8,C7	100pF	CAP/HDC-0201
5	24	C9,C10,C11,C12,C13,C14, C15,C16,C17,C18,C19,C20, C21,C22,C23,C24,C25,C26, C27,C28,C29,C30,C31,C32	open0402	CAP/HDC-0402
6	6	C34,C40,C45,C48,C51,C59	0.01uF	CAP/HDC-0603
7	6	C35,C41,C46,C49,C52,C60	0.1uF	CAP/HDC-0603
8	2	C56,C36	22uF	CAP/N
9	2	C57,C37	2.2uF	3528-21_EIA
10	2	C38,C58	0.1uF	CAP/HDC-1206
11	4	C42,C43,C53,C54	10uF_open	CAP/B
12	1	JP1	2X10-Pin Header, open	Header/2X10P
13	4	JP2,JP3,JP4,JP12	3-Pin Header	Header/3P
14	2	JP13,JP5	2-Pin Header	Header/2P
15	4	JP6,JP7,JP8,JP9	3-Pin Header	Header/3P
16	2	JP11,JP10	2-Pin Header_open	Header/2P
17	1	J1	HSD_2X2_open	CON/HSD-4P
18	1	J2	mini USB 5pin	mini_B_USB_surface_mount
19	2	J4,J3	SMA_open	Edge mount
20	1	J5	mini USB 5pin_open	mini_B_USB_surface_mount
21	1	J6	IDC1X4	IDC-1x4
22	1	J7	HEADER 22X2	2x22 0.1"
23	2	J8,J9	BANANA	CON/BANANA-S
24	1	J10	2x4 pin Jumper_open	IDC_2x4
25	1	J11	CONN JACK PWR_open	3-terminal thru hole power jack
26	1	LED1	0402_orange_LED	402
27	1	LED2	0603_green_LED	0603 (Super Thin)
28	1	P1	USB A_open	USB_TYPE_A_4P
29	2	R1,R2	0 ohm_open	RES/HDC-0201
30	2	R3,R4	1K Ohm,0402_open	RES/HDC-0402
31	2	R5,R6	0 ohm	RES/HDC-0201
32	2	R7,R8	49.9ohm_open	RES/HDC-0201
33	1	R9	0 Ohm,0402_open	RES/HDC-0402
34	5	R10,R11,R12,R13,R14	10K	RES/HDC-0603
35	1	R15	100K_open	RES/HDC-0603
36	1	R16	0 Ohm,0402	RES/HDC-0402
37	2	R17,R18	1.0K	RES/HDC-0603
38	6	R19,R21,R22,R23,R25,R27	FB 1000 Ohm,0402	RES/HDC-0402
39	2	R20,R24	82.5ohm	RES/HDC-0603
40	1	R26	100ohm_open	RES/HDC-0603
41	1	S1	SW DIP-4	DIP-10
42	1	U1	DS90UB904Q	48ld LLP
43	2	U2,U3	LM1117IMP-ADJ/SOT223_open	SOT223
44	1	VR1	SVR100K	Surface Mount
45	2	VR2,VR3	SVR100_open	Surface Mount
46	2	X2,X1	TP_0402	TP/0402

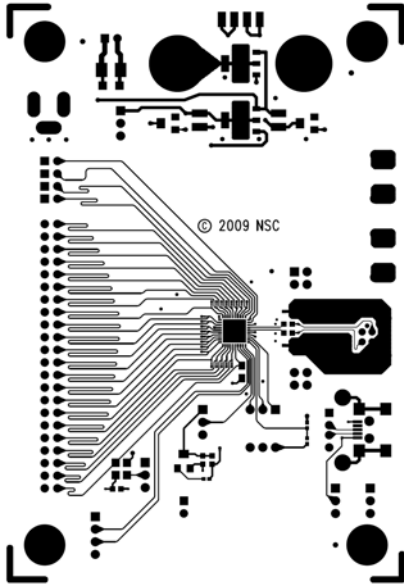

NATIONAL SEMICONDUCTOR CORP.
980600395 FPD-LINK III TX EVB
PWB 551600395-001 REV A
PRIMARY COMP SIDE - LAYER 1

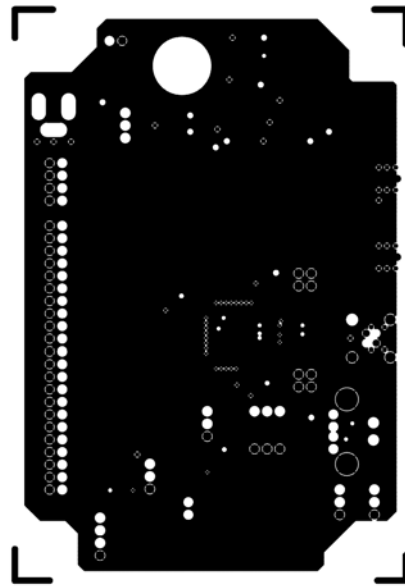

NATIONAL SEMICONDUCTOR CORP.
980600395 FPD-LINK III TX EVB
PWB 551600395-001 REV A
GROUND PLANE - LAYER 2

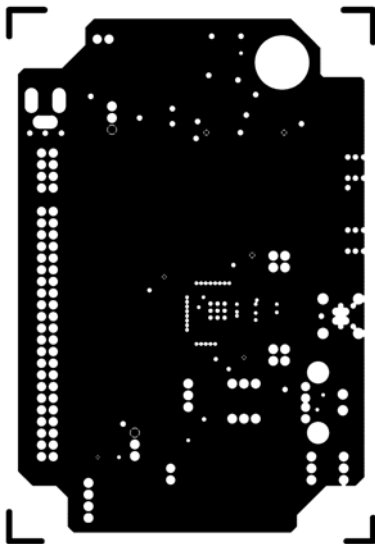

NATIONAL SEMICONDUCTOR CORP.
980600395 FPD-LINK III TX EVB
PWB 551600395-001 REV A
POWER PLANE - LAYER 3

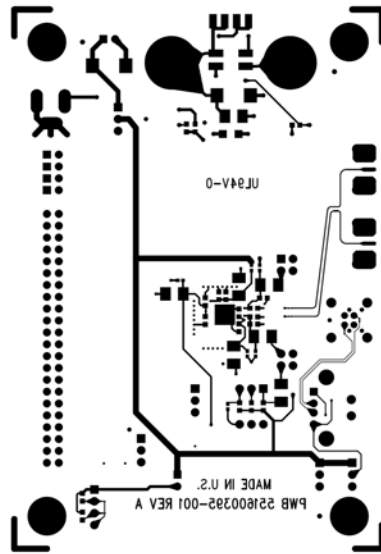

NATIONAL SEMICONDUCTOR CORP.
980600395 FPD-LINK III TX EVB
PWB 551600395-001 REV A
SECONDARY COMP SIDE - LAYER 4

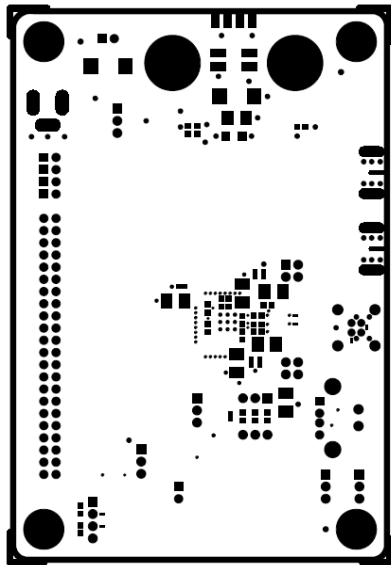

NATIONAL SEMICONDUCTOR CORP.
980600395 FPD-LINK III TX EVB
PWB 551600395-001 REV A
SECONDARY COMP SIDE - SOLDER MASK (LAYER 4)

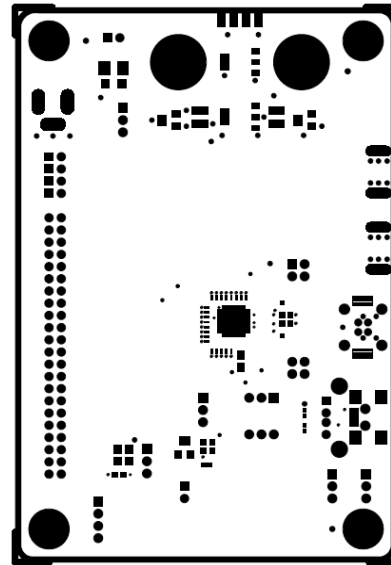

NATIONAL SEMICONDUCTOR CORP.
980600395 FPD-LINK III TX EVB
PWB 551600395-001 REV A
PRIMARY COMP SIDE - SOLDER MASK (LAYER 1)



NATIONAL SEMICONDUCTOR CORP.
980600395 FPD-LINK III TX EVB
PWB 551600395-001 REV A
SECONDARY COMP SIDE - SOLDER PASTE MASK

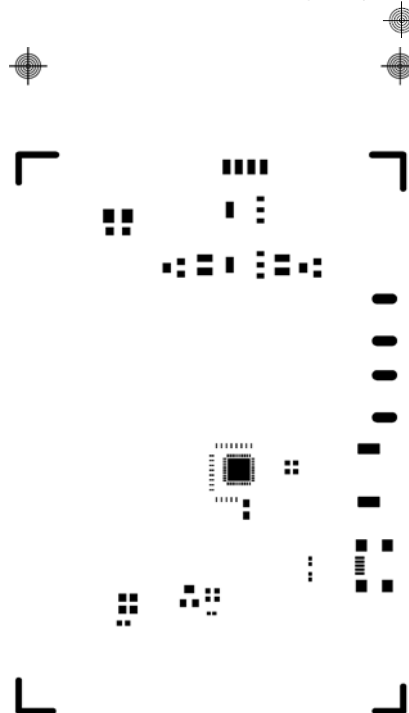

NATIONAL SEMICONDUCTOR CORP.
980600395 FPD-LINK III TX EVB
PWB 551600395-001 REV A
PRIMARY COMP SIDE - SOLDER PASTE MASK

Serializer (Tx) Demo PCB Stackup:

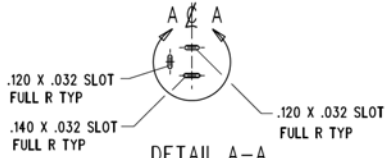
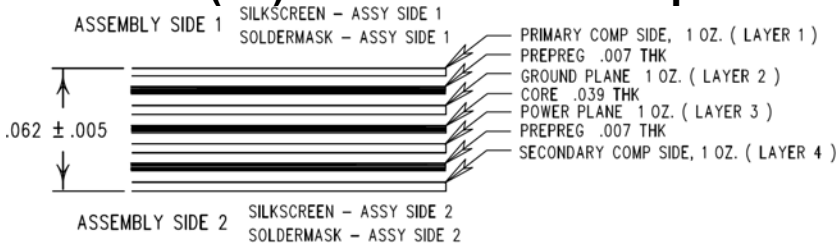

SCALE 1:1 ROT 90° CW
NOTE: .032 DRILL AT SLOT CENTER PER NC DRILL FILE

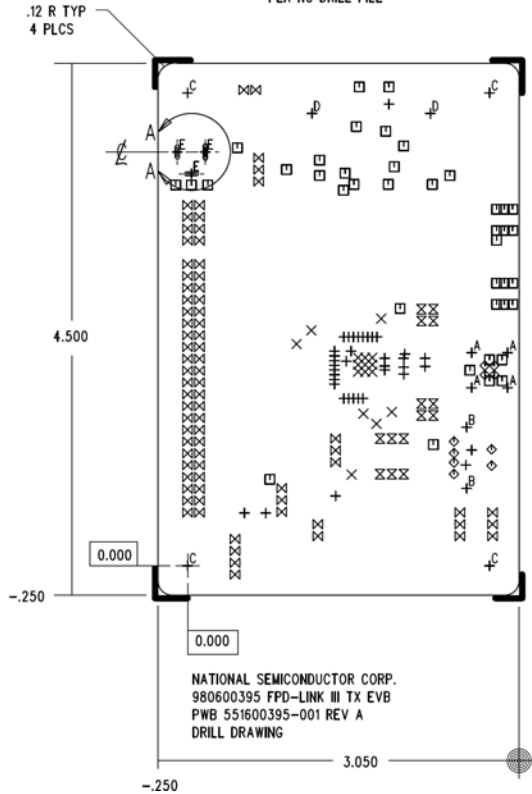

HOLE CHART				
CODE	SIZE	QTY	PLATED	TOL
+	0.006	38	YES	± .003
×	0.010	16	YES	± .003
□	0.016	40	YES	± .003
◇	0.035	10	YES	± .003
⊗	0.040	14	YES	± .003
⊠	0.043	75	YES	± .003
A	0.065	4	YES	± .003
B	0.091	2	YES	± .003
C	0.156	4	YES	± .004
D	0.265	2	YES	± .005
E	0.032	3	YES	± .003

THRU HOLE SLOT - SEE DETAIL A-A

NOTES: UNLESS OTHERWISE SPECIFIED

1. PRIMARY COMPONENT SIDE IS SHOWN.
2. DELETED.
3. FABRICATE USING MASTER FILM PWB 551600395-001 REV A. USE GERBER FILE A675BOA.PHO FOR BOARD ROUTE.
4. ACCEPTABILITY SHALL BE BASED ON IPC-A-600, CLASS 2
5. MATERIAL: BASE MATERIAL IS FR-370HR OR EQUIVALENT, COLOR GREEN, 0.062 INCH NOM. THICKNESS. COPPER CLADDING SHALL BE 1 OZ.
6. PLATING: ALL HOLES AND CONDUCTIVE SURFACES SHALL BE PLATED WITH A MIN. OF .001 INCH COPPER. EXPOSED PADS / TRACES SHALL BE PLATED .000030 MIN GOLD OVER NICKEL, .000150 MIN. ENIG.
7. FABRICATION TOLERANCES:
END PRODUCT CONDUCTOR WIDTHS AND LAND DIAMETERS SHALL NOT VARY MORE THAN .002 INCH FROM THE 1:1 DIMENSIONS OF THE MASTER PATTERN. THE CONDUCTIVE PATTERN SHALL BE POSITIONED SO THAT THE LOCATION OF ANY LAND SHALL BE WITHIN .010 INCH DIAMETER TO THE TRUE POSITION OF THE HOLE IT CIRCUMSCRIBES THE MINIMUM ANNULAR RING SHALL BE .002 INCH. BOW AND TWIST SHALL NOT EXCEED .010 INCH PER INCH.
8. SOLDERMASK BOTH SIDES PER IPC-SM-840, TYPE A, CLASS B. COLOR-GREEN. THERE SHALL BE NO SOLDERMASK ON ANY LAND.
9. SILKSCREEN THE LEGEND ON BOTH SIDES USING NON CONDUCTIVE EPOXY INK, COLOR-WHITE. THERE SHALL BE NO INK ON ANY LAND.
10. THE .00975 TRACES (LAYER 1 & 4) TO BE 50 OHM SINGLE ENDED IMPEDANCE AND THE DIELECTRIC REFERENCED IN BOARD STACK DETAIL IS SUGGESTED. HOWEVER, TRACE WIDTHS AND OR DIELECTRIC THICKNESS MAY BE MICRO-MODIFIED IN ORDER TO FABRICATE BOARDS TO THE REQUIRED IMPEDANCE NOMINALS TO A TOLERANCE OF +/- 10%.
11. PCB MUST BE MADE OF US RECOGNIZED MATERIAL AND TRACEABLE FOR 94V-0 MINIMUM FLAMMABILITY RATING AND MANUFACTURED BY A UL RECOGNIZED PRINTED CIRCUIT BOARD SUPPLIER. PCB MUST BE PERMANENTLY MARKED WITH UL RECOGNIZED MANUFACTURER'S LOGO AND TYPE CODE AS DESIGNATED IN THE UL RECOGNIZED DIRECTORY.

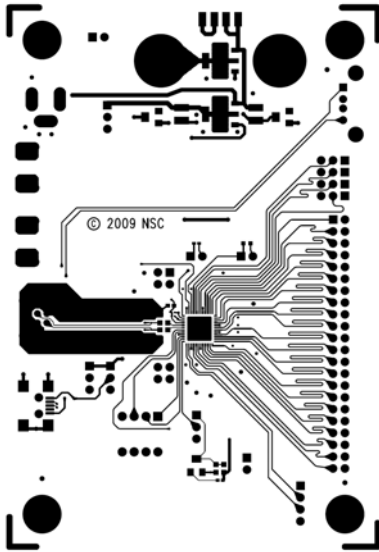

NATIONAL SEMICONDUCTOR CORP.
980600396 FPD-LINK III RX EVB
PWB 551600396-001 REV A
PRIMARY COMP SIDE - LAYER 1

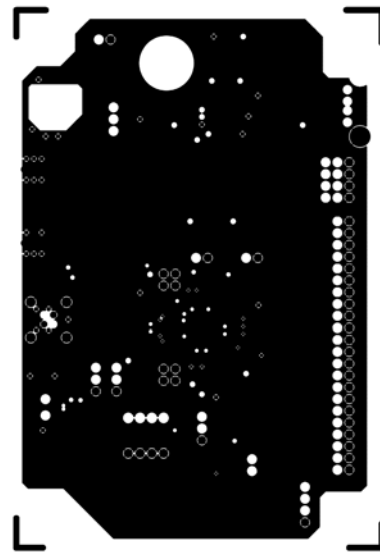

NATIONAL SEMICONDUCTOR CORP.
980600396 FPD-LINK III RX EVB
PWB 551600396-001 REV A
GROUND PLANE - LAYER 2

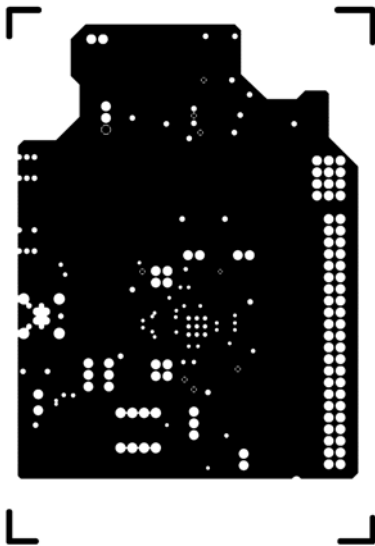

NATIONAL SEMICONDUCTOR CORP.
980600396 FPD-LINK III RX EVB
PWB 551600396-001 REV A
POWER PLANE - LAYER 3

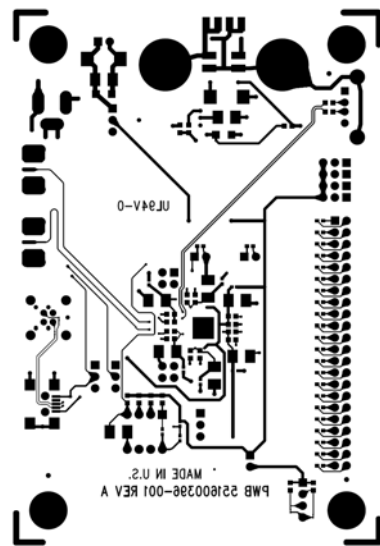

NATIONAL SEMICONDUCTOR CORP.
980600396 FPD-LINK III RX EVB
PWB 551600396-001 REV A
SECONDARY COMP SIDE - LAYER 4

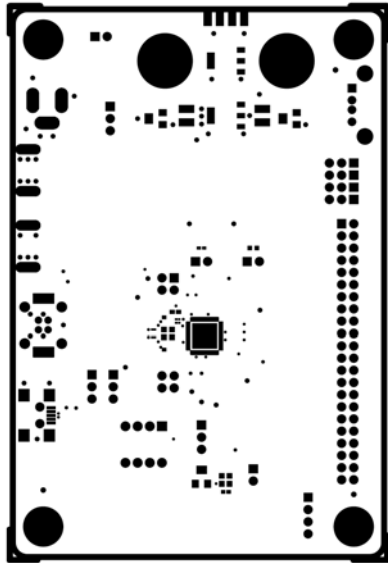

NATIONAL SEMICONDUCTOR CORP.
980600396 FPD-LINK III RX EVB
PWB 551600396-001 REV A
PRIMARY COMP SIDE - SOLDER MASK (LAYER 1)

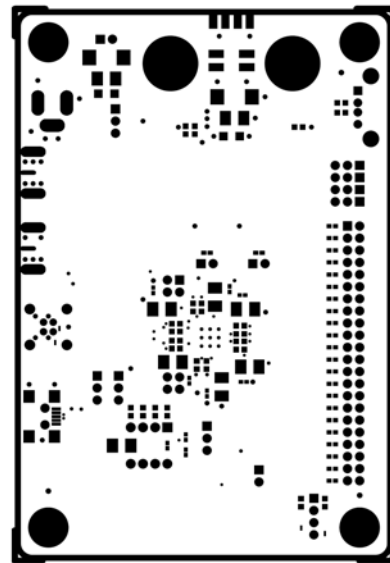

NATIONAL SEMICONDUCTOR CORP.
980600396 FPD-LINK III RX EVB
PWB 551600396-001 REV A
SECONDARY COMP SIDE - SOLDER MASK (LAYER 4)

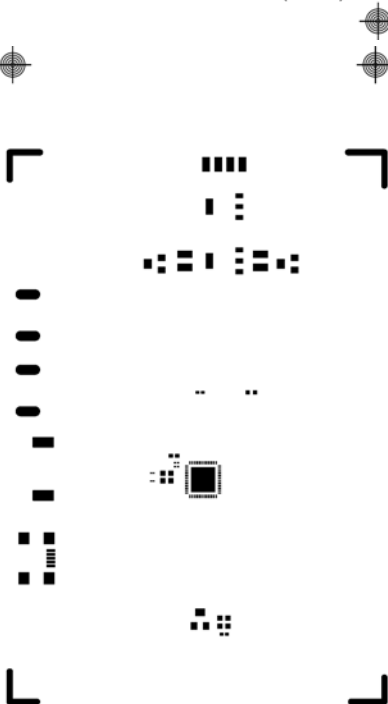

NATIONAL SEMICONDUCTOR CORP.
980600396 FPD-LINK III RX EVB
PWB 551600396-001 REV A
PRIMARY COMP SIDE - SOLDER PASTE MASK

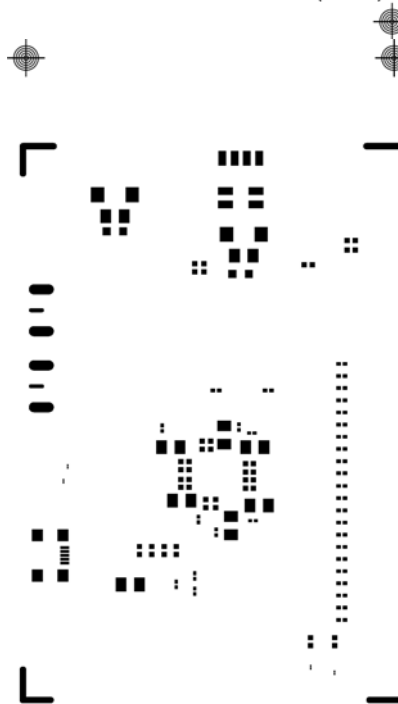

NATIONAL SEMICONDUCTOR CORP.
980600396 FPD-LINK III RX EVB
PWB 551600396-001 REV A
SECONDARY COMP SIDE - SOLDER PASTE MASK

Deserializer (Rx) Demo PCB Stackup:

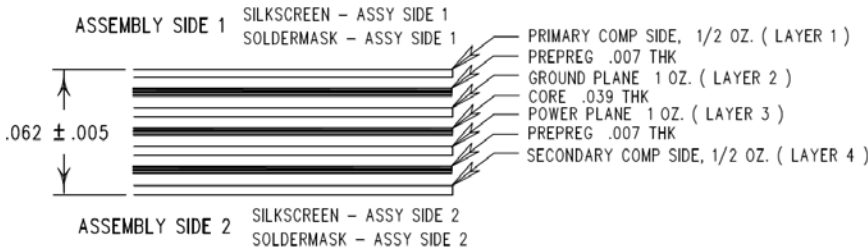

HOLE CHART				
CODE	SIZE	QTY	PLATED	TOL
+	0.006	27	YES	± .003
×	0.010	19	YES	± .003
□	0.016	49	YES	± .003
◇	0.035	10	YES	± .003
⊗	0.040	92	YES	± .003
⊗	0.043	4	YES	± .003
A	0.065	4	YES	± .003
B	0.091	2	YES	± .003
C	0.156	4	YES	± .003
D	0.265	2	YES	± .004
E	0.032	3	YES	± .005

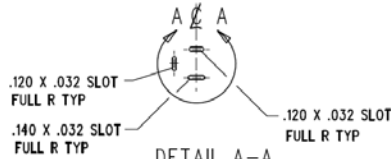

THRU HOLE SLOT - SEE DETAIL A-A

SCALE 1:1 ROT 90° CW
NOTE: .032 DRILL AT SLOT CENTER
PER NC DRILL FILE

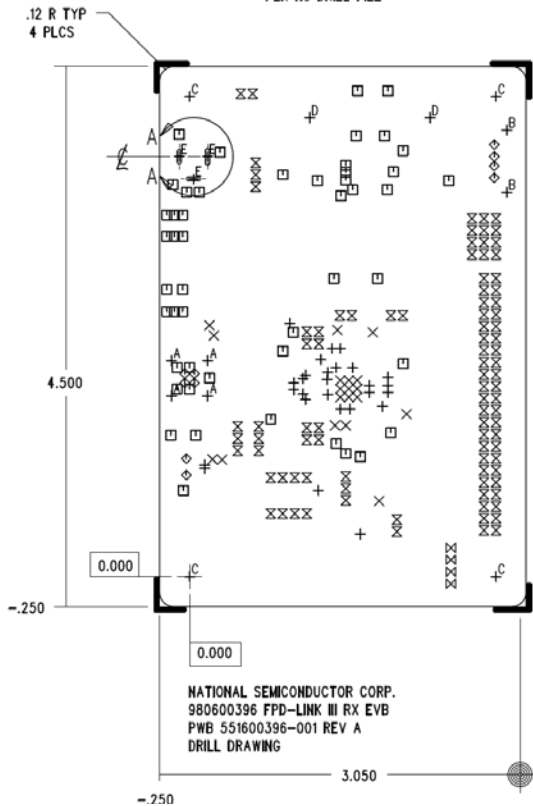

NOTES: UNLESS OTHERWISE SPECIFIED

1. PRIMARY COMPONENT SIDE IS SHOWN.
2. DELETED.
3. FABRICATE USING MASTER FILM PWB 551600396-001 REV A. USE GERBER FILE A676BOA.PHO FOR BOARD ROUTE.
4. ACCEPTABILITY SHALL BE BASED ON IPC-A-600, CLASS 2
5. MATERIAL: BASE MATERIAL IS FR-370HR OR EQUIVALENT, COLOR GREEN, 0.050 INCH NOM. THICKNESS. COPPER CLADDING SHALL BE 1 OZ.
6. PLATING: ALL HOLES AND CONDUCTIVE SURFACES SHALL BE PLATED WITH A MIN. OF .001 INCH COPPER. EXPOSED PADS / TRACES SHALL BE PLATED .000030 MIN GOLD OVER NICKEL, .000150 MIN. ENIG.
7. FABRICATION TOLERANCES:
END PRODUCT CONDUCTOR WIDTHS AND LAND DIAMETERS SHALL NOT VARY MORE THAN .002 INCH FROM THE 1:1 DIMENSIONS OF THE MASTER PATTERN. THE CONDUCTIVE PATTERN SHALL BE POSITIONED SO THAT THE LOCATION OF ANY LAND SHALL BE WITHIN .010 INCH DIAMETER TO THE TRUE POSITION OF THE HOLE IT CIRCUMSCRIBES THE MINIMUM ANNULAR RING SHALL BE .002 INCH. BOW AND TWIST SHALL NOT EXCEED .010 INCH PER INCH.
8. SOLDERMASK BOTH SIDES PER IPC-SM-840, TYPE A, CLASS B. COLOR-GREEN. THERE SHALL BE NO SOLDERMASK ON ANY LAND.
9. SILKSCREEN THE LEGEND ON BOTH SIDES USING NON CONDUCTIVE EPOXY INK, COLOR-WHITE. THERE SHALL BE NO INK ON ANY LAND.
10. THE .00975 TRACES (LAYER 1 & 4) TO BE 50 OHM SINGLE ENDED IMPEDANCE AND THE DIELECTRIC REFERENCED IN BOARD STACK DETAIL IS HOWEVER, TRACE WIDTHS AND OR DIELECTRIC THICKNESS MAY BE MICRO-MODIFIED IN ORDER TO FABRICATE BOARDS TO THE REQUIRED IMPEDANCE NOMINALS TO A TOLERANCE OF +/- 10%.
11. PCB MUST BE MADE OF US RECOGNIZED MATERIAL AND TRACEABLE FOR 94V-0 MINIMUM FLAMMABILITY RATING AND MANUFACTURED BY A UL RECOGNIZED PRINTED CIRCUIT BOARD SUPPLIER. PCB MUST BE PERMANENTLY MARKED WITH UL RECOGNIZED MANUFACTURER'S LOGO AND TYPE CODE AS DESIGNATED IN THE UL RECOGNIZED DIRECTORY.

FCC Warning

This evaluation board/kit is intended for use for **ENGINEERING DEVELOPMENT, DEMONSTRATION, OR EVALUATION PURPOSES ONLY** and is not considered by TI to be a finished end-product fit for general customer use. It generates, uses, and can radiate radio frequency energy and has not been tested for compliance with the limits of computing devices pursuant to part 15 of FCC rules, which are designed to provide reasonable protection against radio frequency interference. Operation of this equipment in other environments may cause interference with radio communications, in which case the user at his own expense will be required to take whatever measures may be required to correct this interference.

EVALUATION BOARD/KIT IMPORTANT NOTICE

Texas Instruments (TI) provides the enclosed product(s) under the following conditions:

This evaluation board/kit is intended for use for **ENGINEERING DEVELOPMENT, DEMONSTRATION, OR EVALUATION PURPOSES ONLY** and is not considered by TI to be a finished end-product fit for general consumer use. Persons handling the product(s) must have electronics training and observe good engineering practice standards. As such, the goods being provided are not intended to be complete in terms of required design-, marketing-, and/or manufacturing-related protective considerations, including product safety and environmental measures typically found in end products that incorporate such semiconductor components or circuit boards. This evaluation board/kit does not fall within the scope of the European Union directives regarding electromagnetic compatibility, restricted substances (RoHS), recycling (WEEE), FCC, CE or UL, and therefore may not meet the technical requirements of these directives or other related directives.

Should this evaluation board/kit not meet the specifications indicated in the User's Guide, the board/kit may be returned within 30 days from the date of delivery for a full refund. **THE FOREGOING WARRANTY IS THE EXCLUSIVE WARRANTY MADE BY SELLER TO BUYER AND IS IN LIEU OF ALL OTHER WARRANTIES, EXPRESSED, IMPLIED, OR STATUTORY, INCLUDING ANY WARRANTY OF MERCHANTABILITY OR FITNESS FOR ANY PARTICULAR PURPOSE.**

The user assumes all responsibility and liability for proper and safe handling of the goods. Further, the user indemnifies TI from all claims arising from the handling or use of the goods. Due to the open construction of the product, it is the user's responsibility to take any and all appropriate precautions with regard to electrostatic discharge.

EXCEPT TO THE EXTENT OF THE INDEMNITY SET FORTH ABOVE, NEITHER PARTY SHALL BE LIABLE TO THE OTHER FOR ANY INDIRECT, SPECIAL, INCIDENTAL, OR CONSEQUENTIAL DAMAGES.

TI currently deals with a variety of customers for products, and therefore our arrangement with the user **is not exclusive**.

TI assumes **no liability for applications assistance, customer product design, software performance, or infringement of patents or services described herein**.

Please read the User's Guide and, specifically, the Warnings and Restrictions notice in the User's Guide prior to handling the product. This notice contains important safety information about temperatures and voltages. For additional information on TI's environmental and/or safety programs, please contact the TI application engineer or visit www.ti.com/esh.

No license is granted under any patent right or other intellectual property right of TI covering or relating to any machine, process, or combination in which such TI products or services might be or are used.

EVM WARNINGS AND RESTRICTIONS

It is important to operate this EVM within the input voltage range specified in datasheet.

Exceeding the specified input range may cause unexpected operation and/or irreversible damage to the EVM. If there are questions concerning the input range, please contact a TI field representative prior to connecting the input power.

Applying loads outside of the specified output range may result in unintended operation and/or possible permanent damage to the EVM. Please consult the EVM User's Guide prior to connecting any load to the EVM output. If there is uncertainty as to the load specification, please contact a TI field representative.

During normal operation, some circuit components may have case temperatures greater than 85° C. The EVM is designed to operate properly with certain components above 60° C as long as the input and output ranges are maintained. These components include but are not limited to linear regulators, switching transistors, pass transistors, and current sense resistors. These types of devices can be identified using the EVM schematic located in the EVM User's Guide. When placing measurement probes near these devices during operation, please be aware that these devices may be very warm to the touch.

Mailing Address: Texas Instruments, Post Office Box 655303, Dallas, Texas 75265
Copyright © 2012, Texas Instruments Incorporated

NOTES

IMPORTANT NOTICE

Texas Instruments Incorporated and its subsidiaries (TI) reserve the right to make corrections, modifications, enhancements, improvements, and other changes to its products and services at any time and to discontinue any product or service without notice. Customers should obtain the latest relevant information before placing orders and should verify that such information is current and complete. All products are sold subject to TI's terms and conditions of sale supplied at the time of order acknowledgment.

TI warrants performance of its hardware products to the specifications applicable at the time of sale in accordance with TI's standard warranty. Testing and other quality control techniques are used to the extent TI deems necessary to support this warranty. Except where mandated by government requirements, testing of all parameters of each product is not necessarily performed.

TI assumes no liability for applications assistance or customer product design. Customers are responsible for their products and applications using TI components. To minimize the risks associated with customer products and applications, customers should provide adequate design and operating safeguards.

TI does not warrant or represent that any license, either express or implied, is granted under any TI patent right, copyright, mask work right, or other TI intellectual property right relating to any combination, machine, or process in which TI products or services are used. Information published by TI regarding third-party products or services does not constitute a license from TI to use such products or services or a warranty or endorsement thereof. Use of such information may require a license from a third party under the patents or other intellectual property of the third party, or a license from TI under the patents or other intellectual property of TI. Reproduction of information in TI data books or data sheets is permissible only if reproduction is without alteration and is accompanied by all associated warranties, conditions, limitations, and notices.

Reproduction of this information with alteration is an unfair and deceptive business practice. TI is not responsible or liable for such altered documentation. Resale of TI products or services with statements different from or beyond the parameters stated by TI for that product or service voids all express and any implied warranties for the associated TI product or service and is an unfair and deceptive business practice. TI is not responsible or liable for any such statements.

TI products are not authorized for use in safety-critical applications (such as life support) where a failure of the TI product would reasonably be expected to cause severe personal injury or death, unless officers of the parties have executed an agreement specifically governing such use. Buyers represent that they have all necessary expertise in the safety and regulatory ramifications of their applications, and acknowledge and agree that they are solely responsible for all legal, regulatory and safety-related requirements concerning their products and any use of TI products in such safety-critical applications, notwithstanding any applications-related information or support that may be provided by TI. Further, Buyers must fully indemnify TI and its representatives against any damages arising out of the use of TI products in such safety-critical applications.

TI products are neither designed nor intended for use in military/aerospace applications or environments unless the TI products are specifically designated by TI as military-grade or "enhanced plastic." Only products designated by TI as military-grade meet military specifications. Buyers acknowledge and agree that any such use of TI products which TI has not designated as military-grade is solely at the Buyer's risk, and that they are solely responsible for compliance with all legal and regulatory requirements in connection with such use.

TI products are neither designed nor intended for use in automotive applications or environments unless the specific TI products are designated by TI as compliant with ISO/TS 16949 requirements. Buyers acknowledge and agree that, if they use any non-designated products in automotive applications, TI will not be responsible for any failure to meet such requirements.

Following are URLs where you can obtain information on other Texas Instruments products and application solutions:

Products

Amplifiers	amplifier.ti.com
Data Converters	dataconverter.ti.com
DSP	dsp.ti.com
Interface	interface.ti.com
Logic	logic.ti.com
Power Mgmt	power.ti.com
Microcontrollers	microcontroller.ti.com
RFID	www.ti-rfid.com
Low Power	www.ti.com/lpw
Wireless	

Applications

Audio	www.ti.com/audio
Automotive	www.ti.com/automotive
Broadband	www.ti.com/broadband
Digital Control	www.ti.com/digitalcontrol
Military	www.ti.com/military
Optical Networking	www.ti.com/opticalnetwork
Security	www.ti.com/security
Telephony	www.ti.com/telephony
Video & Imaging	www.ti.com/video
Wireless	www.ti.com/wireless

Looking for pricing, stock, or lifecycle information?

Click below to explore more details on WIN SOURCE:

- ⊖ [View SERDESUB-21USB/NOPB on WIN SOURCE](#)
- ⊖ [Texas Instruments Information](#)

Optimize Your Supply Chain with WIN SOURCE Solutions

- ✓ Global Sourcing Solution
- ✓ Obsolete Management
- ✓ Cost Control Management
- ✓ Shortage Management
- ✓ Alternative Solution
- ✓ Excess Inventory Management