



**THE DATASHEET OF  
SD394EVK/NOPB**



# SD394EVK

## LMH0394 Evaluation Board

### User Guide

National Semiconductor  
EVK User Manual

October 14, 2010



## Overview

The SD394 Evaluation Kit (EVK) enables evaluation of the LMH0394 3G/HD/SD SDI Adaptive Cable Equalizer.

## Evaluation Kit Contents

The EVK contains the following parts:

- SD394EVK board assembly with the LMH0394 cable equalizer
- SD394EVK User Guide

## Evaluation Board Description

Figure 1 shows the SD394 evaluation board and highlights some of its features.

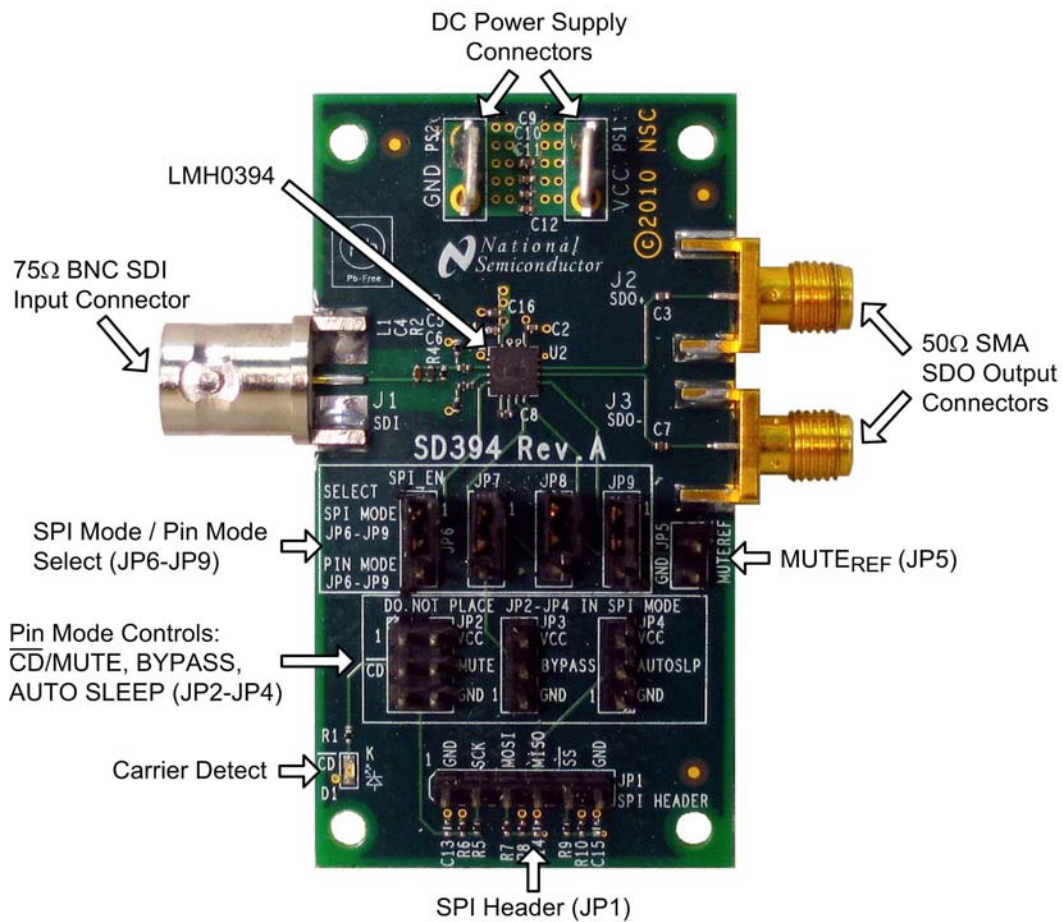

**FIGURE 1. SD394 Evaluation Board**

## SDI Input and SDO Output

The SDI input connector (J1) is a 75Ω BNC connector. The SDI input should conform to the SMPTE 424M, SMPTE 292M, or SMPTE 259M standards.

The SDO output connectors (J2 and J3) are 50Ω SMA connectors. The SDO output connectors have onboard 4.7uF AC coupling capacitors (C3 and C7). When using only one side of the output pair, the other side should be terminated with a 50Ω SMA termination. For example, when only using the SDO output, SDO should be terminated with a 50Ω SMA termination.

## DC Power Connectors

The VCC and GND power connectors, PS1 and PS2 respectively, should be powered with a DC input voltage of 2.5V ± 5%.

## SPI Mode / Pin Mode Select (JP6 – JP9)

JP6, JP7, JP8, and JP9 are used to select between SPI Mode or Pin Mode. To select Pin Mode, set these jumpers in the down position as shown in Figure 2. To select SPI Mode, set these jumpers in the up position as shown in Figure 3. For proper operation, either Pin Mode or SPI Mode must be selected. **Do not leave JP6-JP9 open.**

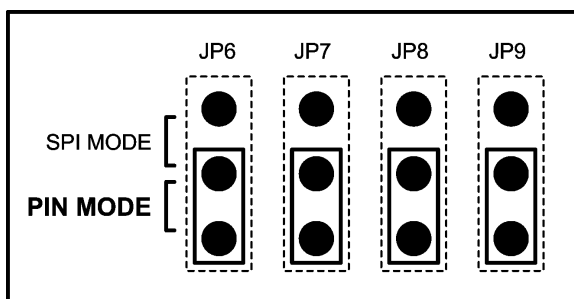

FIGURE 2. Pin Mode Select

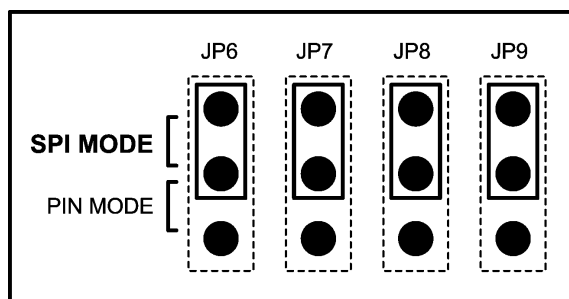

FIGURE 3. SPI Mode Select

## MUTERE<sub>REF</sub> (JP5)

JP5 allows control of the MUTERE<sub>REF</sub> function and may be used in either Pin Mode or SPI Mode. MUTERE<sub>REF</sub> is an input voltage used to set the threshold for  $\overline{CD}$ . The MUTERE<sub>REF</sub> DC input voltage should be between 0V and 2.5V. Refer to the LMH0394 datasheet for details. Leave JP5 unconnected for normal operation.

## Pin Mode Controls (JP2 – JP4)

JP2, JP3, and JP4 are used to control the  $\overline{CD}$  and Mute, Bypass, and Auto Sleep functions while the device is configured in Pin Mode. **Do not place jumpers on JP2, JP3, or JP4 while the device is configured for SPI Mode.**

## $\overline{CD}$ and MUTE (JP2)

JP2 allows Carrier Detect ( $\overline{CD}$ ) monitoring and MUTE control.  $\overline{CD}$  is high when no input signal is present. MUTE may be used to force the outputs on or off, or tied to  $\overline{CD}$  to allow automatic mute operation if the SDI signal is not present. To activate mute and force the outputs into a muted condition, set the jumper to pull MUTE to VCC. To

turn off mute so that the outputs will never mute, set the jumper to tie MUTE to GND. For normal operation, set the jumper to tie  $\overline{CD}$  to MUTE for automatic mute control. The MUTE pin has an internal pulldown (to disable mute), so JP2 may be left unconnected and the device will never mute.

### **BYPASS (JP3)**

JP3 allows control of the equalization BYPASS function. To put the device into bypass mode, set the jumper to pull BYPASS to VCC. To turn off bypass (for normal operation) set the jumper to pull BYPASS to GND. The BYPASS pin has an internal pulldown (to disable bypass), so JP2 may be left unconnected for normal operation.

### **AUTO SLEEP (JP4)**

JP4 allows control of the AUTO SLEEP function. To put the device into auto sleep mode in which it will power down when no input is detected, set the jumper to pull AUTO SLEEP to VCC. To turn off auto sleep and prevent the LMH0394 from automatically powering down, set the jumper to pull AUTO SLEEP to GND. The AUTO SLEEP pin has an internal pullup (to enable auto sleep), so JP4 may be left unconnected to enable auto sleep mode.

### **SPI Header (JP1)**

JP1 is the SPI (Serial Peripheral Interface) header. It allows access to the SPI pins ( $\overline{SS}$ , MISO, MOSI, and SCK) while the LMH0394 is in SPI mode. These pins may be connected to a standard SPI controller to access the LMH0394 SPI registers. Refer to the LMH0394 datasheet for details.

### **Carrier Detect LED (D1)**

D1 shows the status of Carrier Detect. This LED is GREEN when an input signal has been detected, and OFF when no input is detected. D1 shows the status of Carrier Detect while in Pin Mode or SPI Mode.

# Typical Performance

## Equalizer Output

Figures 4, 5, and 6 show output waveforms for the SD394 with various Belden 1694A cable lengths. The input signal is a 2.97 Gbps PRBS10, and the output signal is measured on the Agilent DCA-J 86100C oscilloscope.

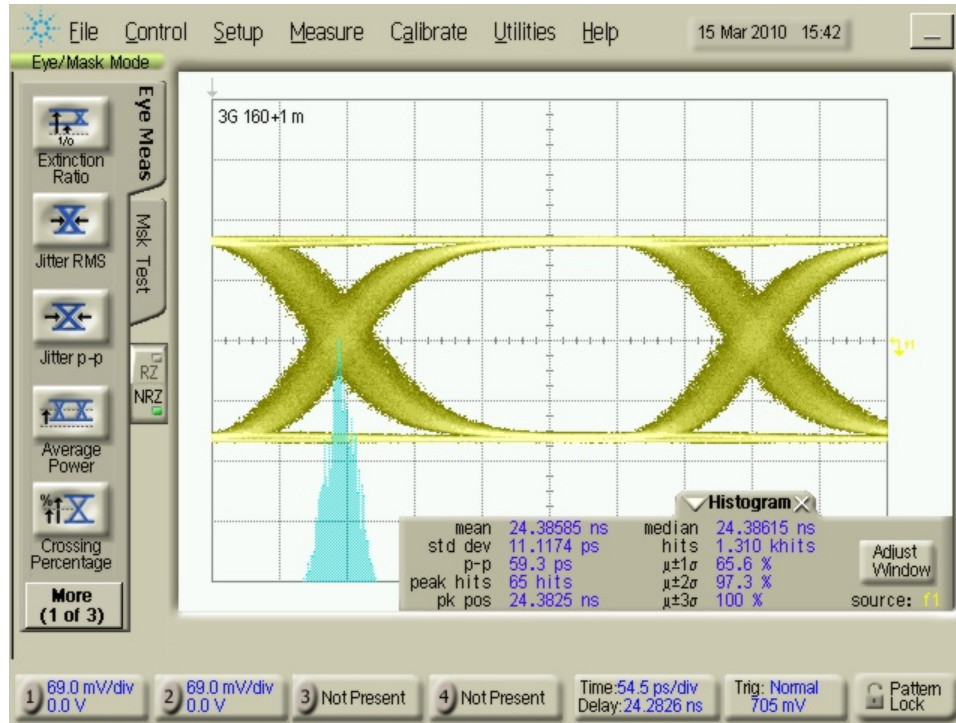

FIGURE 4. SD394 Output Waveform at 2.97 Gbps with 160m Belden 1694A Cable

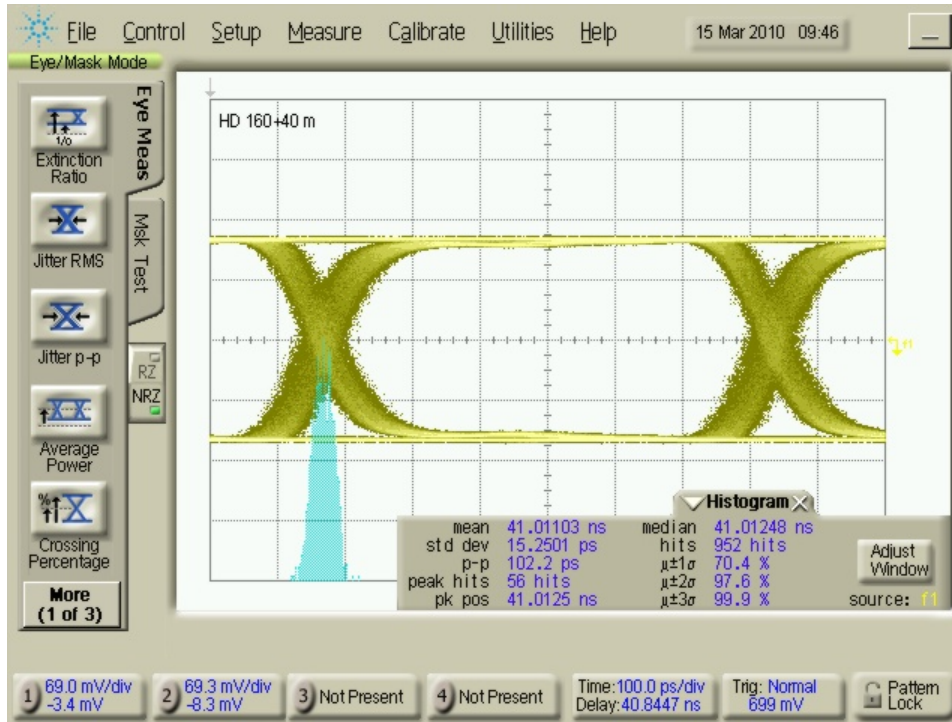

FIGURE 5. SD394 Output Waveform at 1.485 Gbps with 200m Belden 1694A Cable

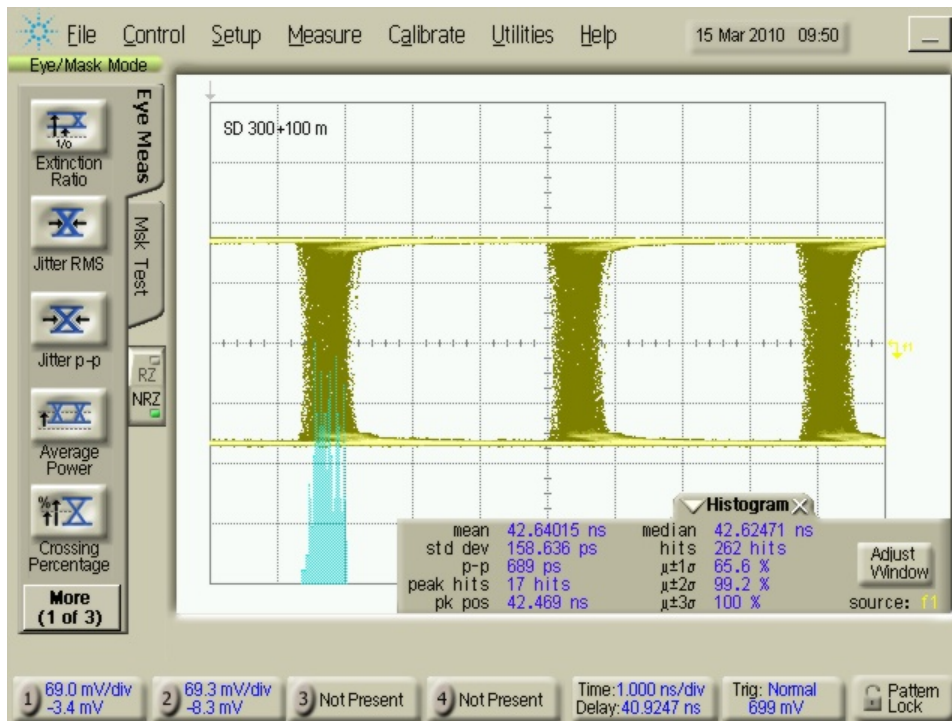

FIGURE 6. SD394 Output Waveform at 270 Mbps with 400m Belden 1694A Cable

## Input Return Loss

Figure 7 shows input return loss of the LMH0394 as measured at the BNC on the SD394. The return loss is measured using the Agilent 8722ES VNA with a 75Ω BNC to 75Ω Type N connector on the input. Note that return loss is layout dependent.

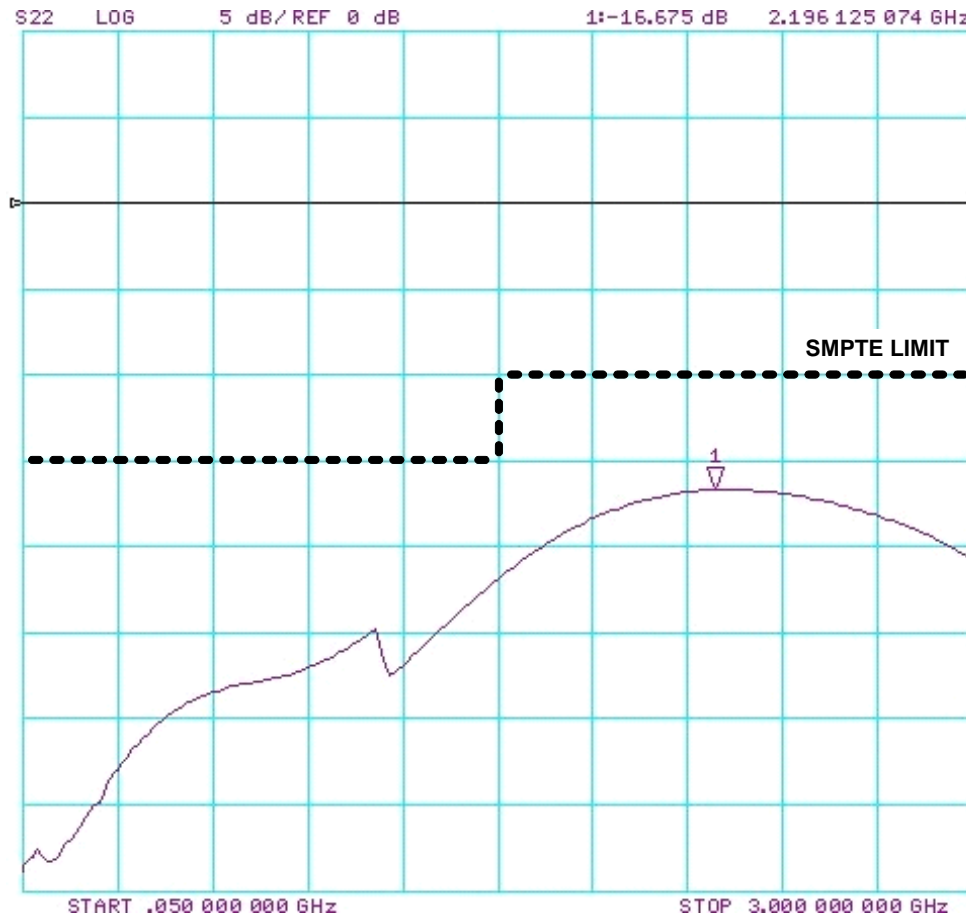

FIGURE 7. SD394 Input Return Loss

## SD394 Bill of Materials

Reference Designator	Qty	Description	Manufacturer	Manufacturer Part No.
C1, C2, C12	3	Capacitor, 0.01uF, 16V, X7R, 0402	Panasonic - ECG	ECJ-0EB1C103K
C3, C7, C9, C16	4	Capacitor, 4.7uF, 6.3V, X5R, 0402	Panasonic - ECG	ECJ-0EB0J475M
C5, C6	2	Capacitor, 1uF, 6.3V, X5R, 0402	Panasonic - ECG	ECJ-0EB0J105M
C10, C11	2	Capacitor, 0.1uF, 16V, X7R, 0402	Kemet	C0402C104K9RACTU
D1	1	LED, Green, 0603	Lite-On	LTST-C190GKT
J1	1	BNC, 75-ohm, Amphenol, edge launch	Amphenol	031-6009
J2, J3	2	SMA, 50-ohm, edge launch	Johnson Components	142-0701-851
JP1	1	Header, 6x1, 0.1"	3M/ESD	929647-01-06-I
JP2	1	Header, 3x2, 0.1"	3M/ESD	929665-01-03-I
JP3, JP4, JP6, JP7, JP8, JP9	6	Header, 3x1, 0.1"	3M/ESD	929647-01-36-I
JP5	1	Header, 2x1, 0.1"	3M/ESD	929647-01-02-I
L1	1	Inductor, 5.6nH, 0402	Murata	LQP15MN5N6B02D
PST1, PST2	2	Power Supply Terminal	Keystone	1287-ST
R1	1	Resistor, 300-ohm, 1/10W, 5%, 0603	Panasonic - ECG	ERJ-3GEYJ301V
R2, R3	2	Resistor, 75-ohm, 1/16W, 1%, 0402	Yageo America	RC0402FR-0775RL
R4	1	Resistor, 37.4-ohm, 1/16W, 1%, 0402	Vishay/Dale	CRCW040237R4FKED
R5, R7, R9	3	Resistor, 3.16k-ohm, 1/10W, 1%, 0402	Panasonic - ECG	ERJ-2RKF3161X
R6, R8, R10	3	Resistor, 9.76k-ohm, 1/10W, 1%, 0402	Panasonic - ECG	ERJ-2RKF9761X
R11	1	Resistor, 0-ohm, 1/10W, 5%, 0402	Panasonic - ECG	ERJ-2GE0R00X
U2	1	LMH0394 Cable Equalizer, LLP-16	National Semiconductor	LMH0394SQ

**Schematic (next page)**

**LMH0384**

VCC(PST1)	2.5V
R5	3.16K
R7	0
R9	3.16K
R6	9.76K
R8	9.76K
R10	9.76K
	0
	Do Not Load
	Do Not Load
	Do Not Load

**LMH0394**

VCC(PST1)	3.3V
R5	0
R7	0
R9	0
R6	Do Not Load
R8	Do Not Load
R10	Do Not Load

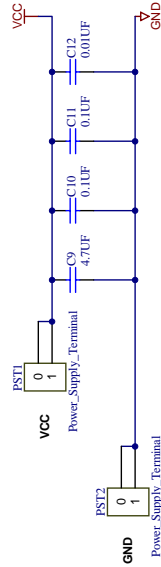

Place C1,C16, & C2 as close to U2 pin as possible/VCC

LAYOUT NOTE:  
Z75\_n,W=20MIL, ZO=75+-5%

LAYOUT NOTE:  
Z50\_n,W=40MIL, ZO=50+-5%

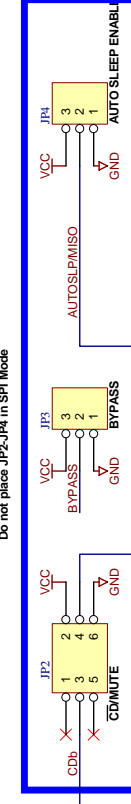

Do not place JP2-JP4 in SPI Mode

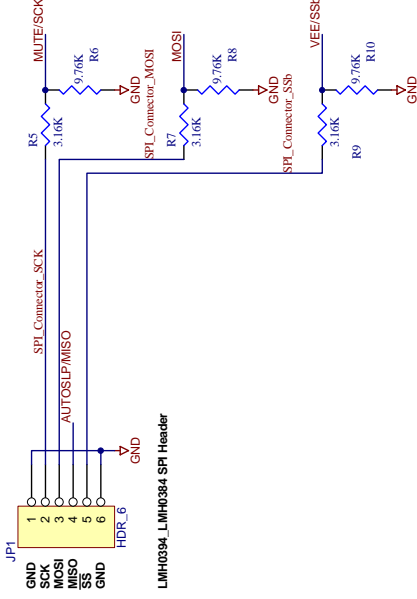
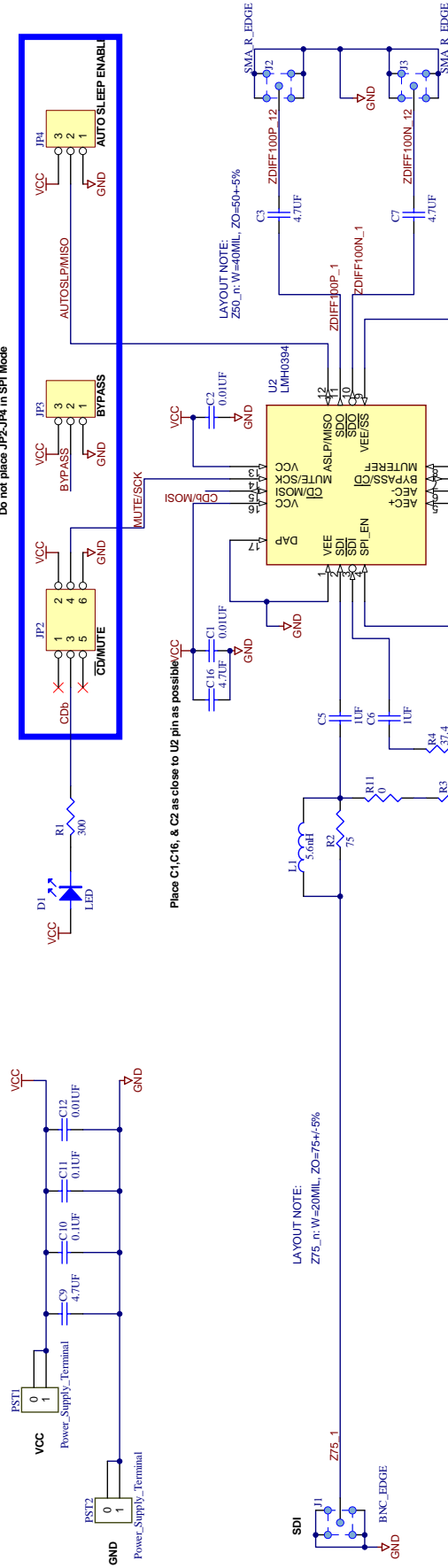

LMH0384-LMH0384 SPI Mode / Pin Mode Select (JP6-JP9)

SPI Mode  
Pin Mode

## IMPORTANT NOTICE

Texas Instruments Incorporated and its subsidiaries (TI) reserve the right to make corrections, modifications, enhancements, improvements, and other changes to its products and services at any time and to discontinue any product or service without notice. Customers should obtain the latest relevant information before placing orders and should verify that such information is current and complete. All products are sold subject to TI's terms and conditions of sale supplied at the time of order acknowledgment.

TI warrants performance of its hardware products to the specifications applicable at the time of sale in accordance with TI's standard warranty. Testing and other quality control techniques are used to the extent TI deems necessary to support this warranty. Except where mandated by government requirements, testing of all parameters of each product is not necessarily performed.

TI assumes no liability for applications assistance or customer product design. Customers are responsible for their products and applications using TI components. To minimize the risks associated with customer products and applications, customers should provide adequate design and operating safeguards.

TI does not warrant or represent that any license, either express or implied, is granted under any TI patent right, copyright, mask work right, or other TI intellectual property right relating to any combination, machine, or process in which TI products or services are used. Information published by TI regarding third-party products or services does not constitute a license from TI to use such products or services or a warranty or endorsement thereof. Use of such information may require a license from a third party under the patents or other intellectual property of the third party, or a license from TI under the patents or other intellectual property of TI.

Reproduction of TI information in TI data books or data sheets is permissible only if reproduction is without alteration and is accompanied by all associated warranties, conditions, limitations, and notices. Reproduction of this information with alteration is an unfair and deceptive business practice. TI is not responsible or liable for such altered documentation. Information of third parties may be subject to additional restrictions.

Resale of TI products or services with statements different from or beyond the parameters stated by TI for that product or service voids all express and any implied warranties for the associated TI product or service and is an unfair and deceptive business practice. TI is not responsible or liable for any such statements.

TI products are not authorized for use in safety-critical applications (such as life support) where a failure of the TI product would reasonably be expected to cause severe personal injury or death, unless officers of the parties have executed an agreement specifically governing such use. Buyers represent that they have all necessary expertise in the safety and regulatory ramifications of their applications, and acknowledge and agree that they are solely responsible for all legal, regulatory and safety-related requirements concerning their products and any use of TI products in such safety-critical applications, notwithstanding any applications-related information or support that may be provided by TI. Further, Buyers must fully indemnify TI and its representatives against any damages arising out of the use of TI products in such safety-critical applications.

TI products are neither designed nor intended for use in military/aerospace applications or environments unless the TI products are specifically designated by TI as military-grade or "enhanced plastic." Only products designated by TI as military-grade meet military specifications. Buyers acknowledge and agree that any such use of TI products which TI has not designated as military-grade is solely at the Buyer's risk, and that they are solely responsible for compliance with all legal and regulatory requirements in connection with such use.

TI products are neither designed nor intended for use in automotive applications or environments unless the specific TI products are designated by TI as compliant with ISO/TS 16949 requirements. Buyers acknowledge and agree that, if they use any non-designated products in automotive applications, TI will not be responsible for any failure to meet such requirements.

Following are URLs where you can obtain information on other Texas Instruments products and application solutions:

### Products

Audio	<a href="http://www.ti.com/audio">www.ti.com/audio</a>
Amplifiers	<a href="http://amplifier.ti.com">amplifier.ti.com</a>
Data Converters	<a href="http://dataconverter.ti.com">dataconverter.ti.com</a>
DLP® Products	<a href="http://www.dlp.com">www.dlp.com</a>
DSP	<a href="http://dsp.ti.com">dsp.ti.com</a>
Clocks and Timers	<a href="http://www.ti.com/clocks">www.ti.com/clocks</a>
Interface	<a href="http://interface.ti.com">interface.ti.com</a>
Logic	<a href="http://logic.ti.com">logic.ti.com</a>
Power Mgmt	<a href="http://power.ti.com">power.ti.com</a>
Microcontrollers	<a href="http://microcontroller.ti.com">microcontroller.ti.com</a>
RFID	<a href="http://www.ti-rfid.com">www.ti-rfid.com</a>
OMAP Mobile Processors	<a href="http://www.ti.com/omap">www.ti.com/omap</a>
Wireless Connectivity	<a href="http://www.ti.com/wirelessconnectivity">www.ti.com/wirelessconnectivity</a>

### Applications

Automotive and Transportation	<a href="http://www.ti.com/automotive">www.ti.com/automotive</a>
Communications and Telecom	<a href="http://www.ti.com/communications">www.ti.com/communications</a>
Computers and Peripherals	<a href="http://www.ti.com/computers">www.ti.com/computers</a>
Consumer Electronics	<a href="http://www.ti.com/consumer-apps">www.ti.com/consumer-apps</a>
Energy and Lighting	<a href="http://www.ti.com/energy">www.ti.com/energy</a>
Industrial	<a href="http://www.ti.com/industrial">www.ti.com/industrial</a>
Medical	<a href="http://www.ti.com/medical">www.ti.com/medical</a>
Security	<a href="http://www.ti.com/security">www.ti.com/security</a>
Space, Avionics and Defense	<a href="http://www.ti.com/space-avionics-defense">www.ti.com/space-avionics-defense</a>
Video and Imaging	<a href="http://www.ti.com/video">www.ti.com/video</a>

TI E2E Community Home Page

[e2e.ti.com](http://e2e.ti.com)

Mailing Address: Texas Instruments, Post Office Box 655303, Dallas, Texas 75265  
Copyright © 2012, Texas Instruments Incorporated

## Looking for pricing, stock, or lifecycle information?

Click below to explore more details on WIN SOURCE:

 [View SD394EVK/NOPB on WIN SOURCE](#)

 [Texas Instruments](#) Information

## Optimize Your Supply Chain with WIN SOURCE Solutions

-  Global Sourcing Solution
-  Obsolete Management
-  Cost Control Management
-  Shortage Management
-  Alternative Solution
-  Excess Inventory Management