



**THE DATASHEET OF
SN65LVDS387EVM**



16-Channel LVDS Driver/Receiver Evaluation Module

User's Guide

Read This First

About This Manual

This is the user's guide for the SN65LVDS387EVM and SN65LVDS386 evaluation modules (EVMs). It contains information on the evaluation modules (EVMs) for Texas Instruments' SN65LVDS387 16-channel LVDS driver and for the SN65LVDS386 16-channel LVDS receiver.

Two separate EVMs are available, allowing each LVDS device to be tested individually using a single EVM for that device. If both EVMs are used, the LVDS output signals from the SN65LVDS387EVM 16-channel LVDS driver can be connected to the LVDS inputs of the 16-channel LVDS receiver on the SN65LVDS386EVM. This allows users to simulate performance of an LVDS system. Recommended test equipment and evaluation and interconnect guidelines are provided for both 16-channel point-to-point and multidrop configurations. The EVMs are CE compliant for distribution within the European Community.

How to Use This Manual

This document contains the following chapters:

- Chapter 1 – Introduction
- Chapter 2 – The Evaluation Boards
- Chapter 3 – Equipment Required
- Chapter 4 – Operation
- Appendix A – Parts List and Schematics

Trademarks

BergStick is a registered trademark of Berg Electronics. All other trademarks are the property of their respective owners.

Contents

1	Introduction	1-1
2	The Evaluation Boards	2-1
2.1	SN65LVDS387 16-Channel LVDS Line Driver	2-3
2.2	SN65LVDS386 16-Channel LVDS Line Receiver	2-5
3	Equipment Required	3-1
3.1	Pattern Generator	3-2
3.2	Oscilloscope and Scope Probes	3-2
3.3	Power Supply	3-2
3.4	Cables	3-2
4	Operation	4-1
4.1	SN65LVDS387 Operation	4-2
4.2	SN65LVDS386 Operation	4-3
4.3	System Evaluation Using Both the SN65LVDS387EVM and SN65LVDS386EVM	4-3
	4.3.1 Point-to-Point Configuration	4-3
	4.3.2 Multidrop Configuration	4-3
4.4	References	4-5
A	Parts List and Schematics	A-1
A.1	Parts List for EVMs	A-2
A.2	Schematic Diagrams 6420201 and 6420202	A-3

Figures

2-1.	EVM Simplified I/O Block Diagram	2-2
2-2.	SN65LVDS387EVM	2-4
2-3.	SN65LVDS386EVM	2-6
4-1.	Examples of Multidrop Interconnections	4-4

Introduction

This is the user's guide for the evaluation modules (EVMs) for the Texas Instruments' SN65LVDS387EVM 16-channel LVDS driver EVM and the SN65LVDS386EVM 16-channel LVDS receiver EVM. One manual is used for both EVMs because the boards are similar for both devices. The EVMs are CE-compliant for distribution within the European Community.

Low-voltage differential signaling (LVDS), as documented in TIA/EIA-644, is a balanced signaling method used for high-speed transmission of binary data over copper. It is well recognized that the benefits of balanced-data transmission begin to outweigh the cost advantages of single-ended techniques when signal-transition times approach 10 nS. This represents signaling rates approaching 30 Megabits per second (Mbps) Presently, LVDS devices operate with signaling rates in the hundreds of Mbps. This performance is achieved with reduced power consumption and reduced electromagnetic interference (EMI) emissions compared to other data transmission standards, such as TIA/EIA-422 and TIA/EIA-232 (also known as RS-232 and RS-422, respectively), PECL, etc. Project collateral discussed in this user's guide can be downloaded from the following URL: <http://www.ti.com/lit/zip/SLLU013>.

Note: To Designers

Both EVMs use the same printed-wiring board (PWB). The 387 device is mounted with the device's pin 1 facing the top of the PWB, and the 386 is mounted with the device's pin 1 facing the bottom of the PWB.

The Evaluation Boards

Each EVM consists of a six-layer printed-wiring board (PWB). The LVDS device and BergStick™ connectors are on the top (connector side) of the board. All other passive components are installed on the underside (component side) of the PWB. A simplified input/output (I/O) block diagram of the EVM is shown in Figure 2–1.

Topic	Page
2.1 SN65LVDS387 16-Channel LVDS Line Driver	2-3
2.2 SN65LVDS386 16-Channel LVDS Line Receiver	2-5

Figure 2–1. EVM Simplified I/O Block Diagram

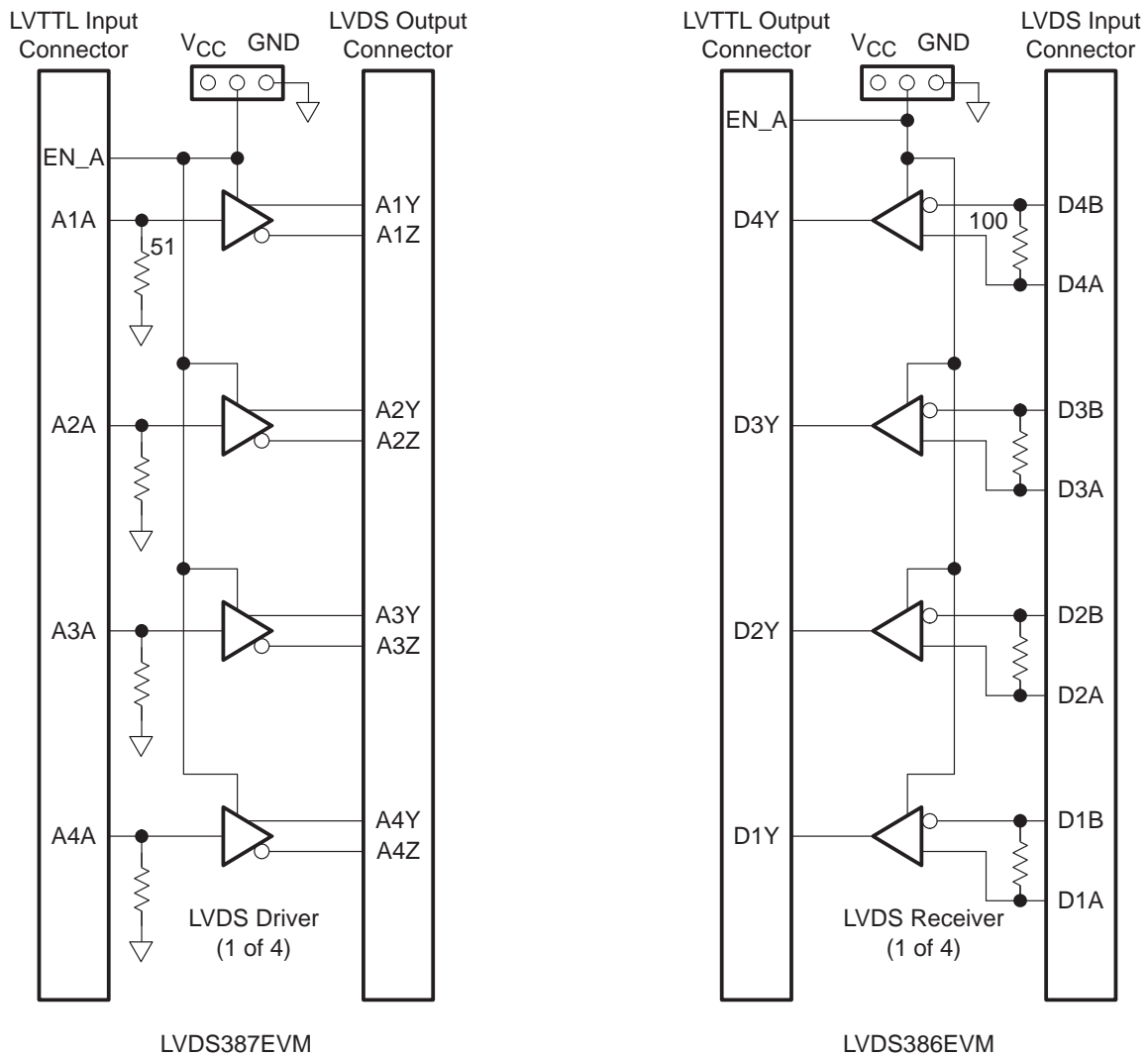

The SN65LVDS387EVM and the SN65LVDS386EVM are discussed in sections 2.1 and 2.2. Use of the schematics in Appendix A will facilitate understanding the detailed discussion that follows.

2.1 SN65LVDS387 16-Channel LVDS Line Driver

This 16-channel LVDS driver accepts 16 low-voltage TTL (LVTTL) inputs and generates 16 LVDS differential outputs (please refer to the schematic in Appendix I). Connectors P1/P2 are the LVTTL I/O connectors. Connectors P3 through P7 are the LVDS I/O connectors. The LVTTL inputs can be provided by any suitable source. As shipped, the SN65LVDS387EVM has 50- Ω termination resistors (R33 through R48) installed on each LVTTL input line to accommodate inputs from a pattern generator or other instrumentation that has a 50- Ω source impedance. If the LVTTL source and cable being used is not a 50- Ω source, then these resistors (resistors R33 through R48) need to be removed. They are required to match the characteristic impedance of the cable (and the source impedance of most pattern generators). These resistors are located on the back (under) side of the SN65LVDS387EVM, next to the P1/P2 connector row.

The other optional components are resistors R1 through R32. Resistors R1 through R16 are left open on the SN65LVDS387EVM. These are used in the LVDS output circuit and, since LVDS lines are normally terminated at the input to the receiver, these 100- Ω resistors are not installed on the EVM. If users want to measure specific performance parameters on the '387, then they are responsible for installing 100-ohm resistors in R1 through R16. Zero-ohm resistors are installed in R17 through R32, which are in series with the LVTTL inputs to the SN65LVDS387. The remaining components are connectors for Vcc and Gnd connections, and decoupling capacitors for the LVDS device. These components are the same for both configurations of the EVM.

There are also four jumpers (JMP1 through JMP4) located next to the P1/P2 connector row. These jumpers control the enable and disable for each four-channel (quad) section of the device. Each of these jumpers consist of three pins and a jumper short. The center pin is connected to the device and the outer pins (top and bottom) are V_{CC} and GND. The jumper short can be moved so contact is made between V_{CC} and the enable/disable pin, or between GND and the enable/disable pin. As shipped, the four jumper shorts are installed to V_{CC} so that all four sections of the device are enabled. A photograph of the SN65LVDS387EVM is shown in Figure 2-2.

Figure 2–2. SN65LVDS387EVM

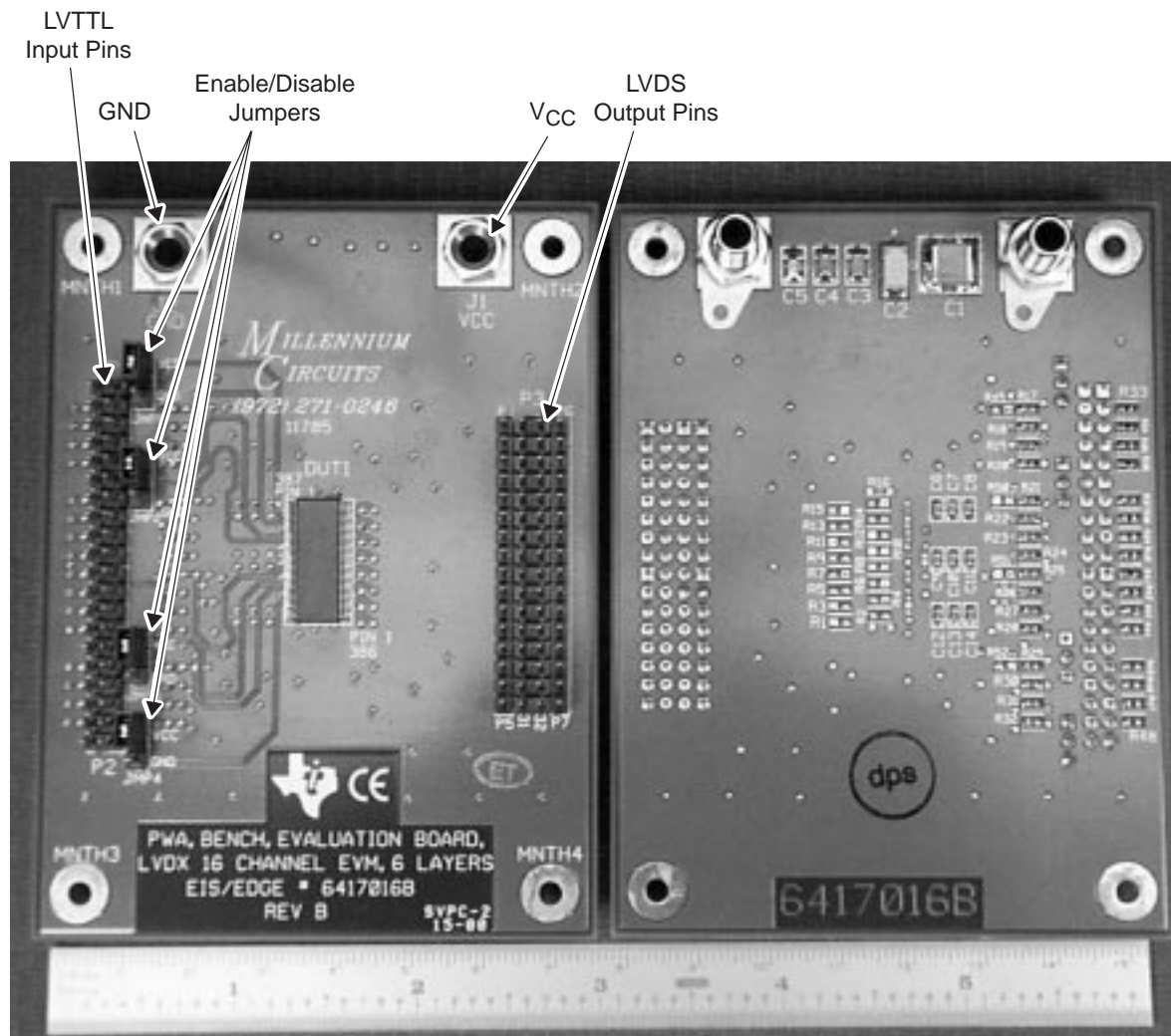

Connector (Top) Side

Component (Bottom) Side

2.2 SN65LVDS386 16-Channel LVDS Line Receiver

The SN65LVDS386EVM accepts 16 LVDS inputs and generates 16 LVTTTL outputs (refer to the schematic in Appendix I). Connectors P3 through P7 (right-side edge) accept the differential LVDS inputs and connector P1/P2 provides the LVTTTL output signals. The *as shipped* configuration of the SN65LVDS386 EVM also contains external resistors required for basic operation and testing of the device. Resistors R1 through R16 are 100- Ω resistors which terminate each LVDS input channel. These are installed on the underside of the SN65LVDS386EVM, very close to the input pins of the device.

The LVTTTL output-channels path (etch on the PWB) contains two *pads* where external resistors may be installed. Resistors R17 through R32 are series resistors where zero-ohm resistors are normally installed. These are followed by resistors R33 through R48, which allow a pull-down resistor to be installed after the series resistor (R17 through R32). As shipped, these pull-down resistors are not installed. The combination of these series (R17 through R32) and pull-down resistors (R 33 through R48) allow the user to install a divider network if desired. This might be necessary if the outputs are to be measured with an instrument having a 50- Ω input impedance. By installing a 475- Ω series resistor and a 50- Ω pull down resistor, a 20:1 divider is created (the 50- Ω pull-down in parallel with the 50- Ω input impedance equals 25 Ω , plus the 475- Ω series impedance of the instrument, for a total load of 500 Ω on the output of the receiver). As shipped, there is no resistor divider installed, and each device LVTTTL output is routed directly to the P1/P2 connectors through a 0- Ω resistor (R17 through R32).

The remaining components are connectors for V_{CC} and GND connections, and decoupling capacitors for the LVDS device (these components are the same for both EVM configurations).

There are also four jumpers (JMP1 through JMP4) located next to the P1/P2 connector row. These jumpers control the enable/disable for each four-channel (quad) section of the device. Each of these jumpers consist of three pins and a jumper short. The center pin is connected to the device and the outer pins (top and bottom) are V_{CC} and GND. The jumper short can be moved so contact is made between V_{CC} and the enable/disable pin, or between GND and the enable/disable pin. As shipped, the jumper shorts are installed to V_{CC} so that all four sections of the device are enabled.

Figure 2–3. SN65LVDS386EVM

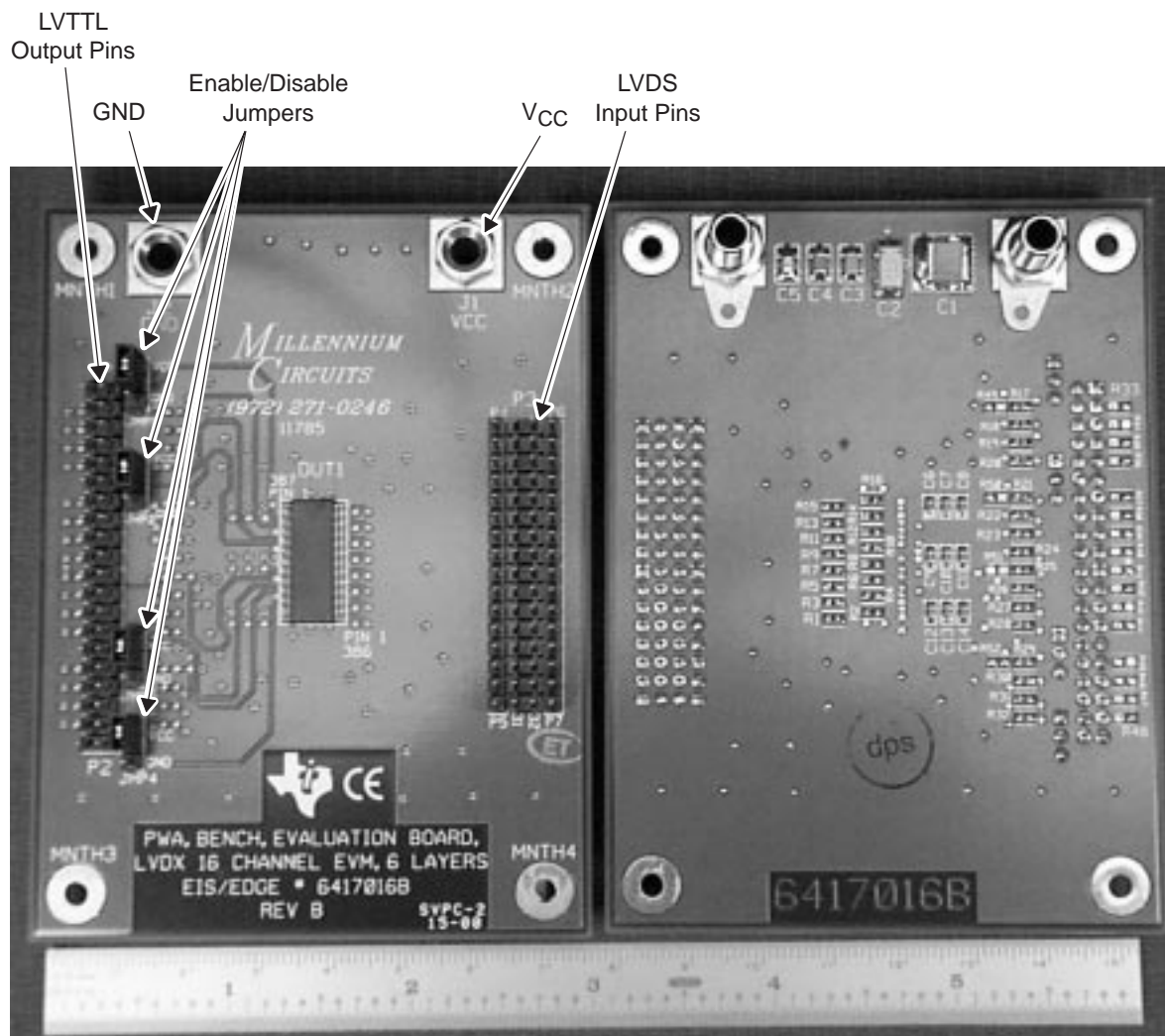

Connector (Top) Side

Component (Bottom) Side

Equipment Required

This chapter provides guidance for selecting the test equipment required to use the EVM.

Topic	Page
3.1 Pattern Generator	3-2
3.2 Oscilloscope and Scope Probes	3-2
3.3 Power Supply	3-2
3.4 Cables	3-2

3.1 Pattern Generator

The SN65LVDS387 EVM requires a signal or pattern generator that can provide at least one LVTTTL input signal to the device. The LVTTTL signal levels provided to the SN65LVDS387EVM must have a $V_{IH} = 2$ Vdc minimum. Sixteen simultaneous LVTTTL inputs are required to fully exercise the device, so a pattern generator with 16 parallel LVTTTL outputs and a signaling-rate range up to several hundred megabits-per-second (Mbps) is suggested. The Tektronix HFS-series of pattern generators, or equivalent, can be used to provide the LVTTTL inputs signals. HFS-9DG1 plug-in cards are recommended as they can be used to provide both single-ended inputs for the SN65LVDS387 driver and differential inputs for the SN65LVDS386 receiver.

3.2 Oscilloscope and Scope Probes

The signaling rates and LVDS signal transitions are very fast (less than 1 nS). To adequately monitor these signals will require an oscilloscope with a minimum bandwidth of 1 GHz. The probes need to have a similar bandwidth to prevent significant measurement errors. A Tektronix 784C oscilloscope with P6243 or P6245 single-ended probes, and P6247 differential probes, or equivalent, is suggested.

3.3 Power Supply

A single-output dc power supply is required to provide Vcc and Gnd to the EVM. This supply is connected to J1 (Vcc) and J2 (GND) on the EVM. An adjustable dc range of 2–4 Vdc and a current of 200 mA dc is required. When testing both the SN65LVDS387EVM and SN65LVDS386EVM together as a system, either a single 500-mA dc-supply can be used, or two separate power supplies may be used so performance with different Vcc levels on each EVM may be evaluated.

3.4 Cables

There are no cables provided with either the SN65LVDS387EVM or the SN65LVDS386EVM. When evaluating either the SN65LVDS387EVM or SN65LVDS386EVM separately, the only cables required are those connecting the input signal source to the input of the EVM. When connecting the SN65LVDS387EVM to the SN65LVDS386EVM to perform system tests, users may evaluate system performance using different types and lengths of cabling. This is done by inserting the bare conductor into the LVDS connectors between the two EVMs (the conductors have to be exposed by removing approximately 1 to 1.5 centimeters of insulation from each conductor). It is recommended to select a cable with a characteristic impedance (Z_0) of $100 \Omega (\pm 10\%)$. Any cable which meets the requirements of EIA-568A Category 5 (CAT5) is recommended.

Operation

The SN65LVDS386 and SN65LVDS387 EVMs provide easy I/O connections for instrumentation. This makes device testing quick and easy. Individual channels can be tested and parameters evaluated for specific applications. In addition, the EVMs are small and compact to allow the entire PWB to be placed in a small temperature chamber. Also, the I/O connectors and enable jumpers are located away from the device, and all external resistors are located on the opposite side of the EVM. This also allows the use of a forced-air temperature controller (such as a Thermostream, or a Temptronics system). The user will notice that the boards are designed such that the LVTTTL I/O connections are made on the left side of the EVM (P1 and P2) and the LVDS I/O connections are made on the right side of each EVM (P3).

Topic	Page
4.1 LVDS387 Operation	4-2
4.2 LVDS386 Operation	4-3
4.3 System Evaluation Using Both the SN65LVDS387EVM and SN65LVDS386EVM	4-3
4.4 References	4-5

4.1 SN65LVDS387EVM Operation

The SN65LVDS387EVM is ready to be used as shipped. When connected to the test instrumentation and 3.3-Vdc power (as described in section 3), performance can be tested and observed. All I/O connections are made using standard BergSticks™ that allow fast and easy connections. These also allow direct connections to oscilloscope probes. BergSticks™ are also used for the enable/disable jumper posts to provide easy connection to external equipment if device response to enable/disable is required. The jumper shorts can be manually placed in either the V_{CC} position (enabled) or the GND position (disabled), or the jumper post can be removed to allow connection to external equipment. Note that there is no 50- Ω termination onboard for the enable/disable pins.

Basic tests of the SN65LVDS387 driver will consist of applying an LVTTTL signal pattern to the P1/P2 input connector and monitoring the output of the driver. When tested as a stand-alone device, 100- Ω termination resistors can be added to the scope probe, or individual 100- Ω termination resistors can be installed on the board (backside of the SN65LVDS387EVM) at R1 through R16. The scope termination is recommended for high-signaling rates to eliminate the stub effects caused by the PWB traces running to the P3 connector.

The input pins on connectors P1 and P2 stagger the input and ground pins row to row. This is done to minimize channel-to-channel crosstalk and interference between input channels. If an LVDS channel is not responding, check to make sure the input connection has not been inverted.

4.2 SN65LVDS386EVM Operation

Like the SN65LVDS387EVM, the SN65LVDS386EVM is shipped with all required components already installed on the board, and is ready for testing. For the LVDS386, differential inputs need to be provided to simulate the differential output-voltage levels (V_{od} is nominally 400 mV) and common-mode output-voltage inputs (nominally 1.2 Vdc) of an LVDS driver. These inputs are easily connected to the right edge P3-P7 LVDS side of the SN65LVDS386EVM. The LVTTTL output signals can be monitored using a scope probe connected directly to the P1/P2 connector pin.

As shipped, each LVDS input channel is terminated with 100- Ω resistors (R1 through R16) across the receiver inputs. These resistors are located on the backside of the EVM near the input pins of the device. Each LVTTTL output pin is routed directly to the P1/P2 connector row. There are provisions on the SN65LVDS386EVM to install a series resistor and a pulldown resistor. This allows users to install a resistor divider on the output if required for testing the device. But, as shipped, the series resistors (R17 through R32) have zero-ohm resistors installed, and the pulldown resistors (R33 through R48) have no components installed.

4.3 System Evaluation Using Both the SN65LVDS387EVM and SN65LVDS386EVM

These EVMs has been designed to allow performance evaluation of both devices when connected together. This allows users to perform tests using the specific type and length of cable between the SN65LVDS387EVM and the SN65LVDS386EVM. Users also has the option to install any specific connectors and to use jumper wires to the BergStick™ connectors. However, it is recommended that any jumper wires be kept as short as possible to minimize their effect on system performance.

4.3.1 Point-to-Point Configuration

The majority of applications will have the outputs of the SN65LVDS387 driver connected directly to an SN65LVDS386 receiver. This point-to-point configuration can be used to perform higher-level system monitoring, such as channel-to-channel skew, crosstalk, and peak-to-peak jitter.

4.3.2 Multidrop Configuration

Using the SN65LVDS387EVM and SN65LVDS386EVM allows the performance of multidrop tests. A multidrop configuration is defined as one in which more than one receiver is connected to a single driver. There are many different multidrop configurations that can be tested using both the SN65LVDS387 and SN65LVDS386EVM. Two possible configurations are shown in Figure 4–1. The termination resistors on the SN65LVDS386EVM will need to be removed as required by the specific multidrop configuration.

Figure 4–1. Examples of Multidrop Interconnections

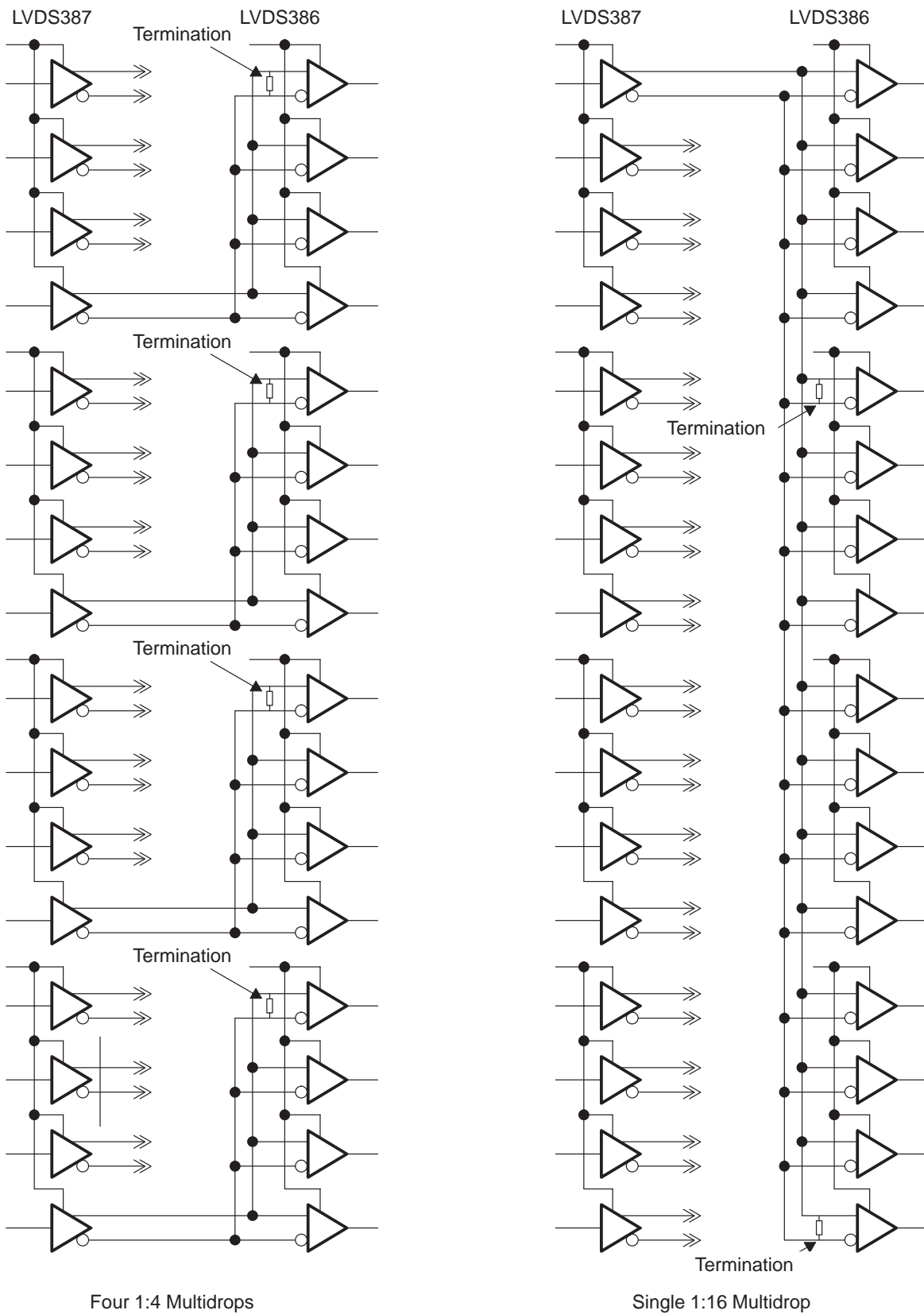

Note:

When testing an SN65LVDS387EVM and SN65LVDS386EVM together, make sure R1 through R16 (100 Ω) are not installed on the SN65LVDS387EVM. Termination of the LVDS signal lines needs to be done on the SN65LVDS386EVM.

4.4 References

There is a wide selection of LVDS devices and related applications materials available to assist in the design and development of LVDS interfaces. This information is located at <http://www.ti.com/sc/datatran>. Input LVDS into the search tool or enter the part number of a specific device to obtain additional information.

For more information on these devices visit TI's web site at http://www.ti.com/sc/docs/apps/analog/lvds_and_lvdm_general_purpose.html

These documents can also be located quickly by inserting the document number into the Quick Research box at our main web site at <http://www.ti.com>.

Data sheets:

- Full data sheet for the LVDS387 in Acrobat PDF: slls362b.pdf (217 KB), or in zipped PostScript: slls362b.psz (214 KB)
- Full data sheet for the LVDS386 in Acrobat PDF: slls394a.pdf (205 KB), or in Zipped PostScript: slls394a.psz (213 KB)

Application materials:

- *Interface Circuits for TIA/EIA-644 (LVDS)* (SLLA038)
- *Low Voltage Differential Signaling (Lvds) Evaluation Module (EVM)* (SLLA033A)
- *Low-Voltage Differential Signaling (LVDS) Design Notes* (SLLA014)
- *LVDS Devices Operate With $V_{CC} = 2.5-V_{dc}$* (SLLA046)
- *LVDS in Harsh Environments With the Next Generation Receivers From TI* (SLLA061)
- *LVDS Multidrop Connections* (SLLA054)
- *Measuring Crosstalk in LVDS Systems* (SLLA064)
- *Performance of LVDS With Different Cables* (SLLA053)
- *Slew Rate Control of LVDS Circuits* (SLLA034A)

Finally, the May 2000 edition of the *TI Applications Journal* contains an article that presents test results from the LVDS387 EVM and LVDS386 EVM when connected together in a point-to-point system using twisted-pair ribbon cable.

Parts List and Schematics

This appendix presents the parts list and schematics for as-shipped configurations of LVDS387 and LVDS386 EVMs. Note that equivalent parts may be used.

Topic	Page
A.1 Parts List for EVMs	A-2
A.2 Schematics	A-3

A.1 Parts List for EVMs

Item	387EVM		386EVM		Manufacturer	Manufacturer Part Number	REF DES	Description	Value or Function
	QTY		QTY						
1	1		1		Millennium Circuits	6417016A	PWB1	PWB	PRINTED WIRING BOARD
2	1		1		Sprague	592D686X9010R2T	C1	Capacitor, SMT, tantalum	10 V, ±10%, 68 µF
3	1		1		Sprague	592D106X9016C2T	C2	Capacitor, SMT, tantalum	16 V, ±10%, 10 µF
4	1		1		AVX	12063G105ZATRA	C3	Capacitor, SMT, Y5V	25V, 80/-20%, 1 µF
5	1		1		AVX	12065C104JATMA	C4	Capacitor, SMT, X7R	50V, ±5%, 0.1 µF
6	1		1		AVX	08051C102JATMA	C5	Capacitor, SMT, X7R	100V, ±5%, 0.001 µF
7	3		3		Panasonic	ECJ-1VB1C104K	C6, C9, C12	Capacitor, SMT	16V, ±5%, 0.1 µF
8	3		3		AVX	06033G103JATMA	C7, C10, C13	Capacitor, SMT, Y5V	25V, ±5%, 0.01 µF
9	3		3		AVX	06033G102JATMA	C8, C11, C14	Capacitor, SMT, Y5V	25V, ±5%, 0.001 µF
10	2		2		ITT-Pomona	3267-PK10	J1, J2	Connector, banana jack	One pin, square
11	1		1		AMP	90F4440	P3	Connector, header, 2 X 16P	Header, male, 2 X 16
12	2		2		AMP	90F7725	P4 – P7	Connector, header, 1 X 16P	Header, 1 x 16,
13	1		1		AMP	90F4440	P1, P2	Connector, header, 2 X 20P	Header, male, 2 X 20
14	1		N/A		Texas Instruments	SN65LVDS387	U1	Integrated circuit, SMT	16-Channel LVDS
15	N/A		1		Texas Instruments	SN65LVDS386	U1	Integrated circuit, SMT	16-Channel LVDS
16	4		4		AMP	4-103239-0X3	JMP1 – JMP4	Header	Make from 4-103239-0X3
17	4		4		AMP	SHUNT/531220-2	JMP1 – JMP4	Header, jumper short	Enable control jumper
18	N/A		16		Panasonic	ERJ-3GSYJ109	R1 – R16	Resistor, SMT	100 Ω, ±1%, 0.001 W
19	16		16		Digi-key	P0.0GCT-ND	R17-R32	Resistor, SMT	0 Ω, 1/16 W, 150 Ω
20	16		N/A		DALE	CRCW060349R9F	R33 – R48	Resistor, SMT	49.9 Ω, ±1%, 0.001 W
21	N/A		N/A		N/A	N/A	R49– R52	Resistor, SMT, 0603, 50 Ω	Reserved for X
22	REF		REF		Texas Instruments	6417016A	—	Schematic	—

A.2 Schematic Diagrams 620201 and 6420202

This section contains the following evaluation board schematic diagrams:

- 6420201, Schematic, Bench, Evaluation Board, SN65LVDS387DGG, EVM
- 6420202, Schematic, Bench, Evaluation Board, SN65LVDS386DGG, EVM

SYM	REVISIONS
A	ECN 2012887, 4/27/00, MPK

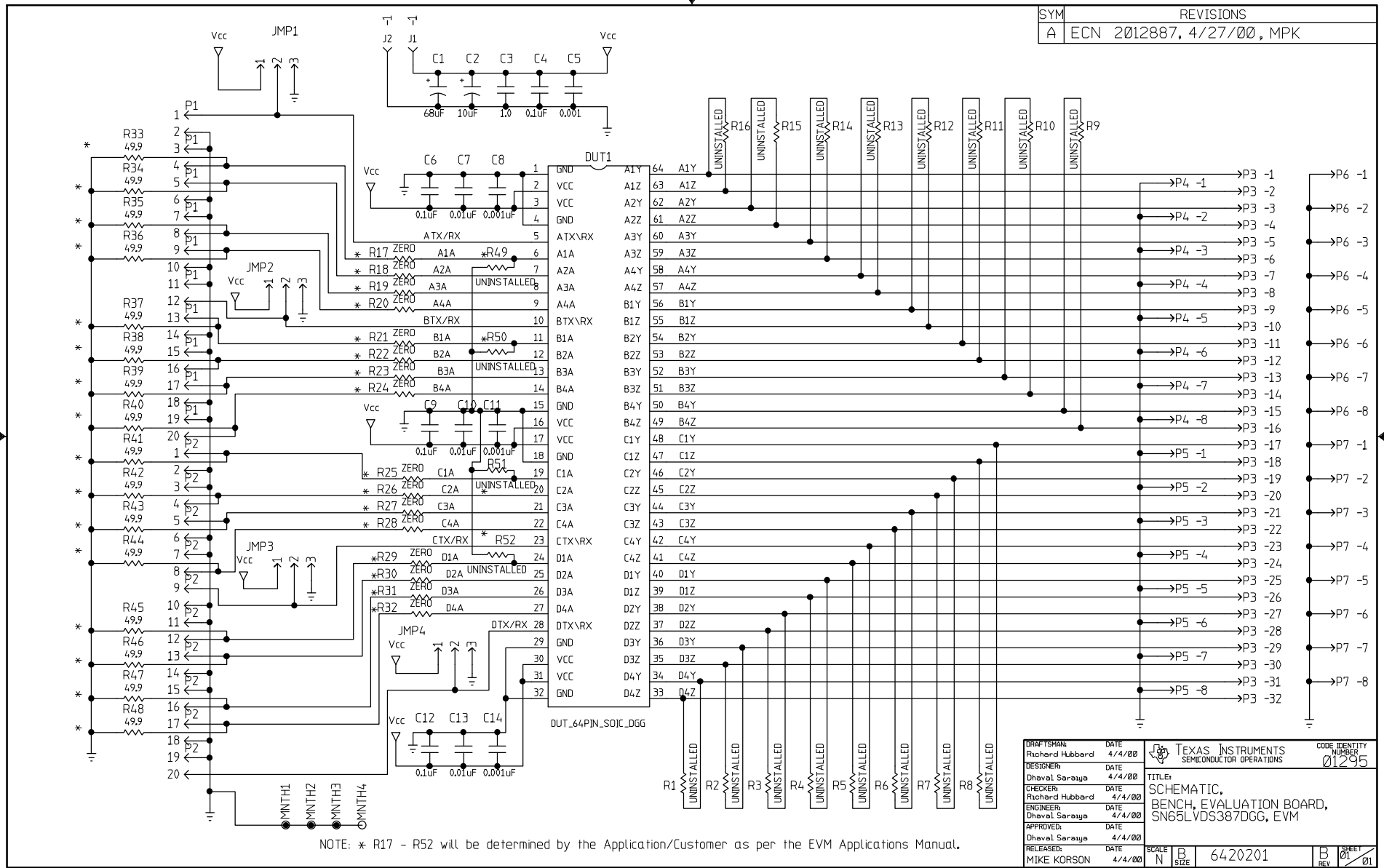

NOTE: * R17 - R52 will be determined by the Application/Customer as per the EVM Applications Manual.

DRAFTSMAN: Richard Hubbard	DATE 4/4/00	TEXAS INSTRUMENTS SEMICONDUCTOR OPERATIONS	CODE IDENTITY NUMBER 01295
DESIGNER: Dhaval Saraya	DATE 4/4/00		TITLE: SCHEMATIC, BENCH, EVALUATION BOARD, SN65LVDS387DGG, EVM
CHECKER: Richard Hubbard	DATE 4/4/00		
ENGINEER: Dhaval Saraya	DATE 4/4/00		
APPROVED: Dhaval Saraya	DATE 4/4/00		
RELEASED: MIKE KORSON	DATE 4/4/00	SCALE N	B SIZE 6420201 B REV 01

SYM	REVISIONS
A	ECN 2012325, 4/4/00, MPK

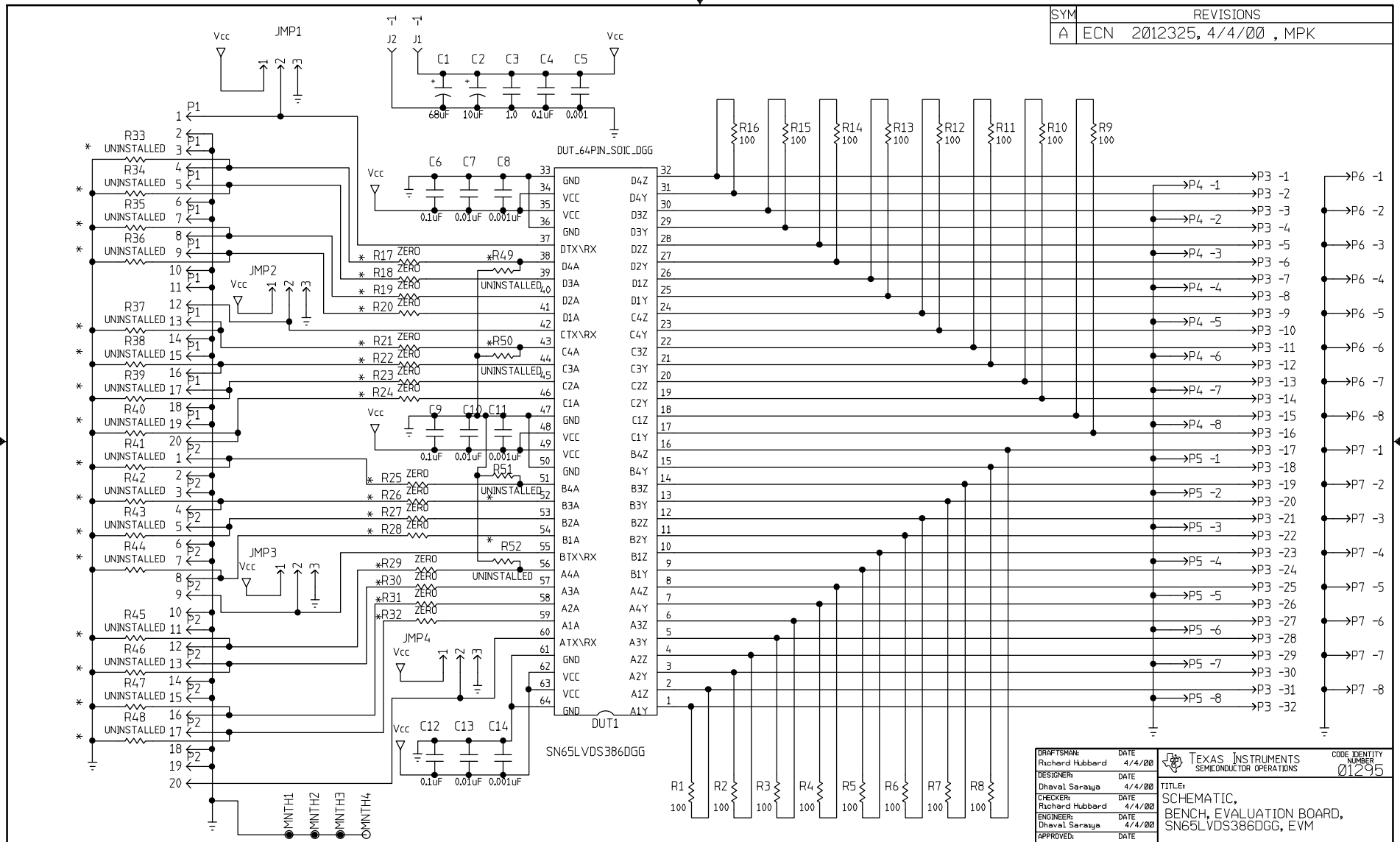

NOTE: * R17 - R52 will be determined by the Application/Customer as per the EVM Applications Manual.

DRAFTSMAN: Richard Hubbard	DATE: 4/4/00	TEXAS INSTRUMENTS SEMICONDUCTOR OPERATIONS	CODE IDENTIFY NUMBER 01295
DESIGNER: Dhaval Saraya	DATE: 4/4/00		TITLE: SCHEMATIC, BENCH, EVALUATION BOARD, SN65LVDS386DGG, EVM
CHECKER: Richard Hubbard	DATE: 4/4/00	SCALE: N	SIZE: B
ENGINEER: Dhaval Saraya	DATE: 4/4/00	6420202	
APPROVED: Dhaval Saraya	DATE: 4/4/00	REV: 01	SHEET 01
RELEASED: MIKE KORSON	DATE: 4/4/00		

IMPORTANT NOTICE AND DISCLAIMER

TI PROVIDES TECHNICAL AND RELIABILITY DATA (INCLUDING DATASHEETS), DESIGN RESOURCES (INCLUDING REFERENCE DESIGNS), APPLICATION OR OTHER DESIGN ADVICE, WEB TOOLS, SAFETY INFORMATION, AND OTHER RESOURCES "AS IS" AND WITH ALL FAULTS, AND DISCLAIMS ALL WARRANTIES, EXPRESS AND IMPLIED, INCLUDING WITHOUT LIMITATION ANY IMPLIED WARRANTIES OF MERCHANTABILITY, FITNESS FOR A PARTICULAR PURPOSE OR NON-INFRINGEMENT OF THIRD PARTY INTELLECTUAL PROPERTY RIGHTS.

These resources are intended for skilled developers designing with TI products. You are solely responsible for (1) selecting the appropriate TI products for your application, (2) designing, validating and testing your application, and (3) ensuring your application meets applicable standards, and any other safety, security, or other requirements. These resources are subject to change without notice. TI grants you permission to use these resources only for development of an application that uses the TI products described in the resource. Other reproduction and display of these resources is prohibited. No license is granted to any other TI intellectual property right or to any third party intellectual property right. TI disclaims responsibility for, and you will fully indemnify TI and its representatives against, any claims, damages, costs, losses, and liabilities arising out of your use of these resources.

TI's products are provided subject to TI's Terms of Sale (www.ti.com/legal/termsofsale.html) or other applicable terms available either on ti.com or provided in conjunction with such TI products. TI's provision of these resources does not expand or otherwise alter TI's applicable warranties or warranty disclaimers for TI products.

Mailing Address: Texas Instruments, Post Office Box 655303, Dallas, Texas 75265
Copyright © 2019, Texas Instruments Incorporated

Looking for pricing, stock, or lifecycle information?

Click below to explore more details on WIN SOURCE:

 [View SN65LVDS387EVM on WIN SOURCE](#)

 [Texas Instruments](#) Information

Optimize Your Supply Chain with WIN SOURCE Solutions

-  Global Sourcing Solution
-  Obsolete Management
-  Cost Control Management
-  Shortage Management
-  Alternative Solution
-  Excess Inventory Management