



**THE DATASHEET OF
SIP32101EVB**



Evaluation Board Manual

THE CHIP

DESCRIPTION

The SiP32101 bidirectional battery switch features reverse blocking capability to isolate the battery from the system. The internal switch has an ultra-low 6.5 mΩ (typ. at 3.3 V) on-resistance and operates from a +2.3 V to +5.5 V input voltage range, making the device ideal battery-disconnect switch for high-capacity battery applications. The SiP32101 has slew rate control, making it ideal in large load capacitor as well as high-current load switching applications. The device also has ultra low operation current. Its shutdown current is of 10 pA (typ.) and quiescent current of 15 pA. The SiP32101 is logic low enable. It can interface with low voltage control signal directly. The SiP32101 is available in an ultra compact 12 bump WCSP package with top size lamination. The device operates over the temperature of -40 °C to +85 °C.

FEATURES

- Bi-directional ON and OFF
- Ultra low R_{on} , 6.5 mΩ (typ.) at 3.3 V
- Wide input voltage, 2.3 V to 5.5 V
- Slew rate controlled turn on
- Ultra-low quiescent current: 15 pA
- EN pin with integrated pull down resistor
- Compact WCSP12 of 1.3 mm x 1.7 mm x 0.55 mm

APPLICATIONS

- Tablets/smart phones
- Battery isolator
- Medical/healthcare systems
- Mobile meters and instruments
- Telecommunication

SIP32101 EVALUATION BOARD

SiP32101 demo board is designed to evaluate the low $R_{DS(on)}$ and bidirectional function of the device.

Power Input and Output Terminals:

These power header terminals (J1 and J2) are designed for easily hood up to the power supply and the load for the evaluation (see fig. 1). The input voltage range for this evaluation is from 2.3 V to 5.5 V. The header J1 is Power Port B. The header J2 is Power Port A. To measure the device resistance, please probe the voltage at K-B (J4) and K-A (J3) illustrated at "Power Port Voltage Sense" section.

CONNECTION AND SIGNAL TEST POINTS

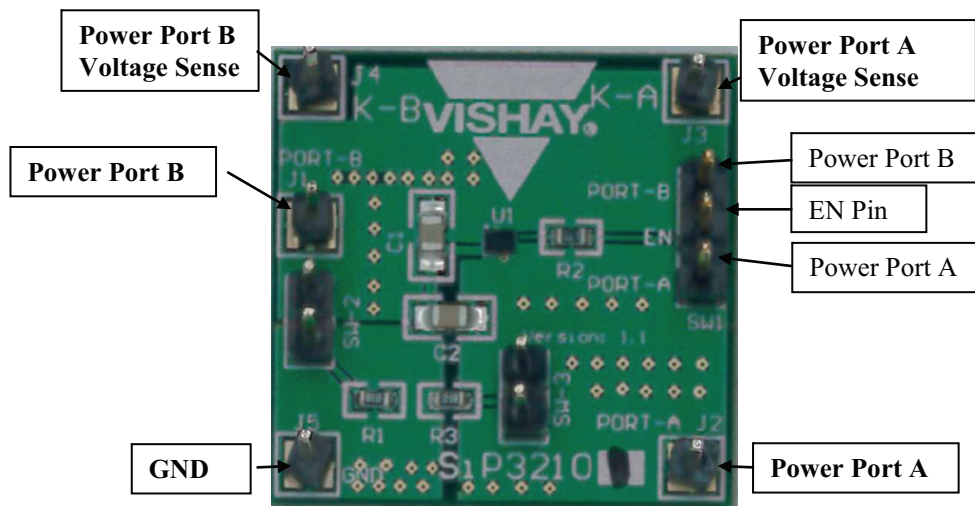

Fig. 1

Input Capacitor and Output Capacitor:

The capacitor C1 and C2 are mounted right next the device to ensure stable voltage right before and after the SiP32101 load switch. The capacitances of these capacitors are 0.1 μ F, 6.3 V.

Enable Terminal Header:

The header SW1 is directly connected to the EN pin of the device (see fig. 1). The EN pin can be toggled to both Power Port A and Power Port B by jumper. For whichever port is input of the device, the EN pin should be connected that port to shut down the device. The SiP32101 is activated low enable. The enable threshold voltage is 1.4 V and the disable threshold voltage is 0.4 V or lower.

Power Port Voltage Sense:

K-B (J4) and K-A (J3) header pins on the demo board provide the Kelvin connection for voltage senses connected right on the Power Port A and Power Port B. They are used to measure the voltage drop across the device. The $R_{DS(on)}$ of the device can be calculated by the measured voltage drop and load current.

SW2 and SW3:

The resistors R1 and R3 are 1 k Ω dummy load on the board for easy test of the enable function of the device. Setting jumper on SW2 will connect R1 to Power Port B. Setting jumper on SW3 will connect R3 to Power Port A.

POWER UP PROCEDURE

SiP32101 is bi-directional switch. Either power port can be input or output.

For port B as input, port A as output; connect positive lead of the power supply to header terminal J1 (Port B). Connect the negative lead of the power supply to header terminal J5 as ground. The voltage range of the power supply is between 2.3 V to 5.5 V as the input voltage of the device. Output load can be applied to header terminal J2 (Port A) and J5 as ground. The maximum load of SiP32101 demo board is rated for maximum current of 5 A. SiP32101 is active high to shut down the device. To shut down the device, EN pin of header terminal can be connected to input (port B) of the device by using jumper to short EN pin and Port B pin on SW1. The EN pin on SW1 must connect to input instead of output.

For Port A as input, Port B as output, connect positive lead of the power supply to the header terminal J2 (Port A). Connect the negative lead of the power supply to header terminal J5 as ground. To shut down the device, EN pin of header terminal can be connected to input (port A) of the device by using jumper to short EN pin and Port A pin on SW1. The EN pin on SW1 must connect to input instead of output.

COMMON TESTS PERFORMED ON THE EVALUATION BOARD

$R_{DS(on)}$ Measurement Setup

The following fig. 2 shows the typical $R_{DS(on)}$ measurement setup. The dropout voltage of the switch is measured on the

power port voltage sense K-B (J4) and K-A (J3). The $R_{DS(on)}$ can be figured out by dividing the dropout voltage by the output load current.

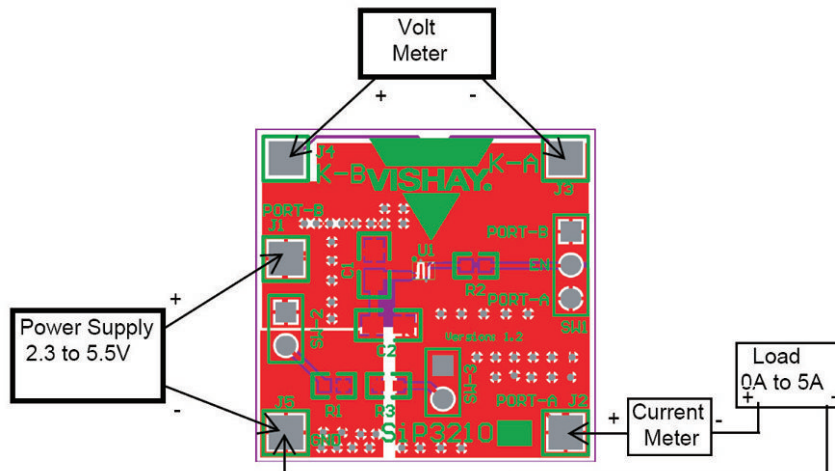

Fig. 2

Enable Slew Rate Power Up

The following fig. 3 shows the typical enable slew rate power up for the rise time measurement of the device. The rise time of the device can be measured by toggling the EN pin with

the signal source and measuring the output rise time with oscilloscope.

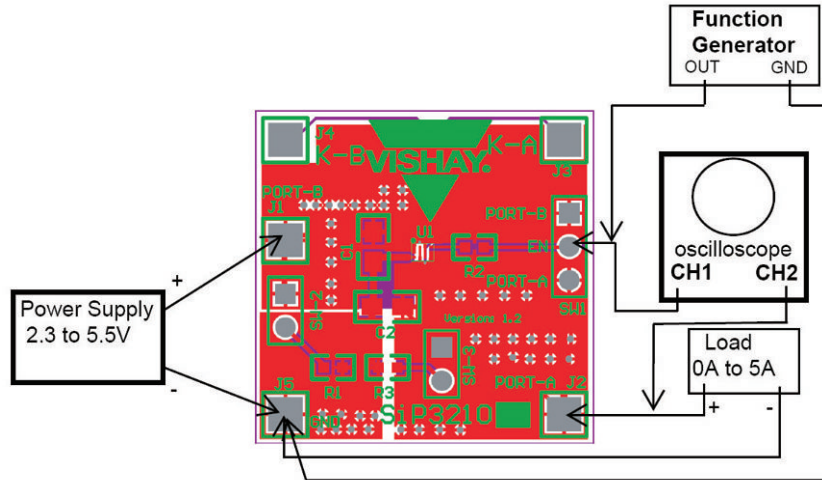

Fig. 3

SIP32101 EVALUATION BOARD SCHEMATIC

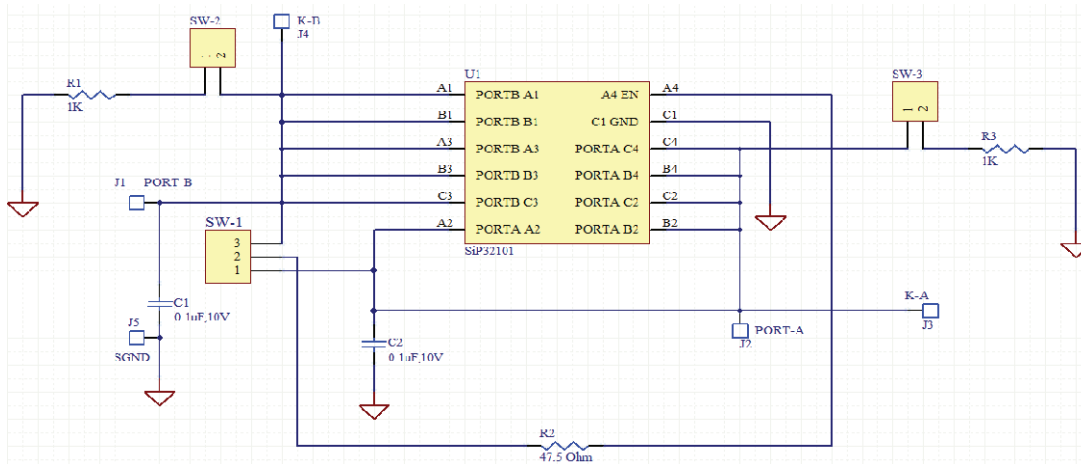
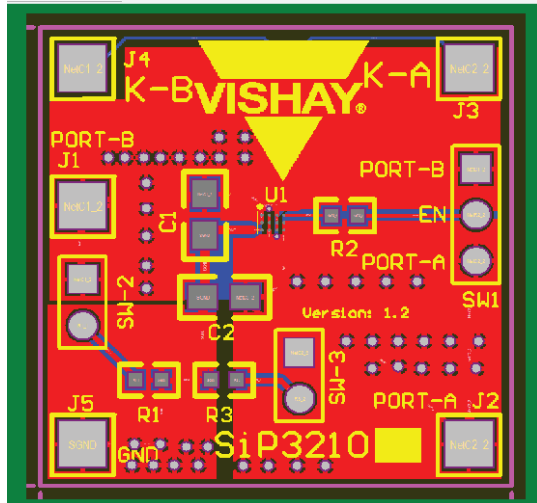
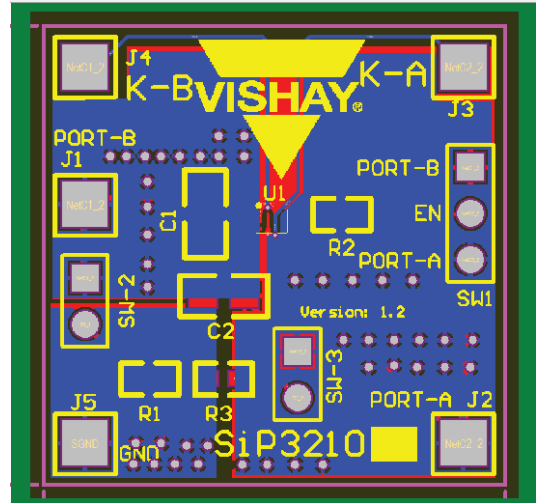

Fig. 4

EVALUATION BOARD LAYOUT



Top View



Bottom View

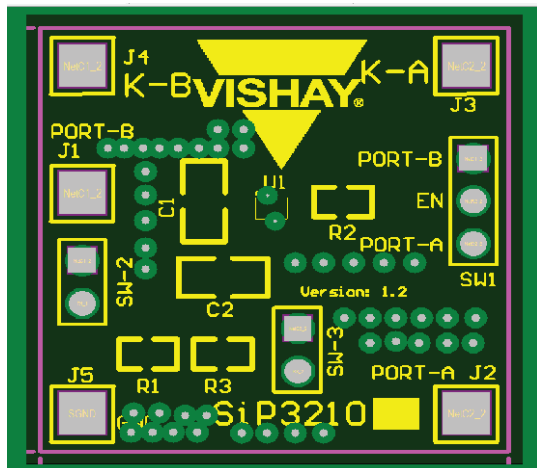

Internal Layer 1

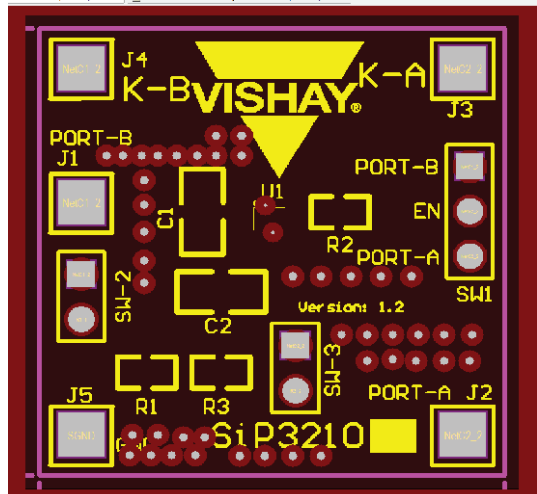

Internal Layer 2



BILL OF MATERIAL				
PATTERN	QUANTITY	COMPONENTS DESIGNATION	DESCRIPTION	PART NUMBER
0603	1	R1	1 kΩ 0603 ± 1%	Generic
0603	1	R2	47.5 Ω 0603 ± 1%	Generic
0603	1	R3	1 kΩ 0603 ± 1%	Generic
0805	1	C1	0.1 μF 0805 ± 20%	Generic
0805	1	C2	0.1 μF 0805 ± 20%	Generic
-	2	SW1, SW2, SW3	2 pin, 2.5 mm pitch header pin	Generic
-	1	SW3	3 pin, 2.5 mm pitch header pin	Generic
BGA4x3	1	U1	SiP32101 device	SiP32101
-	5	J1 to J5	Test pin	Generic
-	1	SiP32101 PCB	Evaluation PCB	Generic

LAB EXPERIMENT RESULT

Enable Power Up

Input Voltage:5.5V
Output Load:2 Ohm

Yellow: Output Voltage Port B
Red: Enable Voltage
Blue: Output Current
Green: Input Voltage Port A

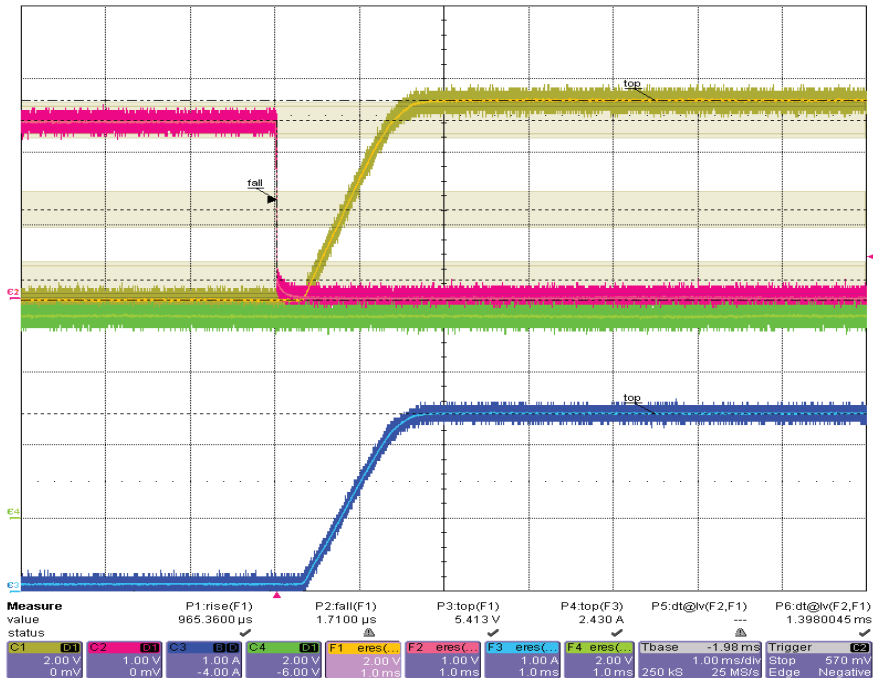



Enable Power Down

Input Voltage:5.5V
Output Load:2 Ohm

Yellow: Output Voltage
Port B
Red: Enable Voltage
Blue: Output Current
Green: Input Voltage Port
A

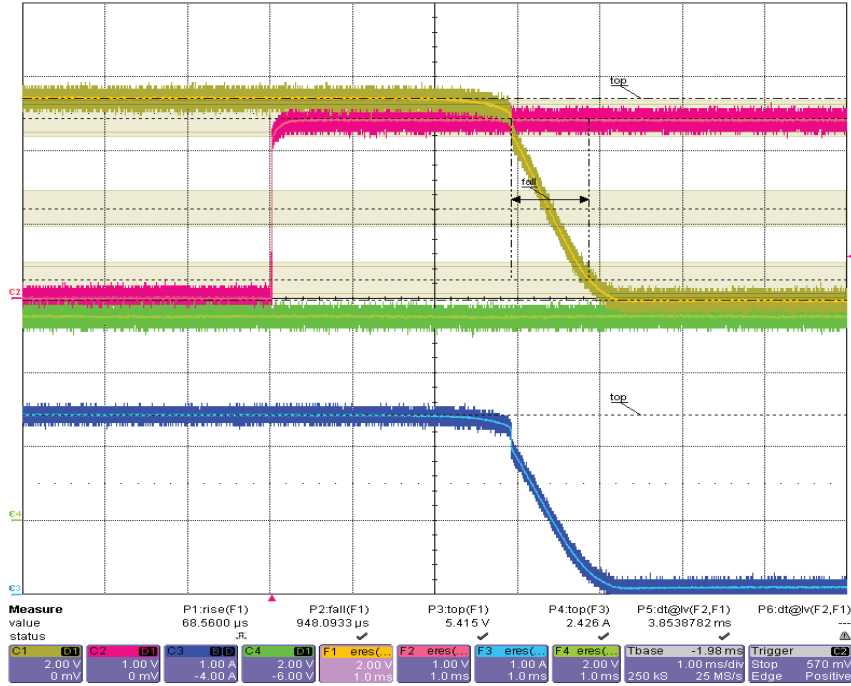

Enable Power Up

Input Voltage:5.5V
Output Load:2 Ohm

Yellow: Output Voltage
Port A
Red: Enable Voltage
Blue: Output Current
Green: Input Voltage Port
B

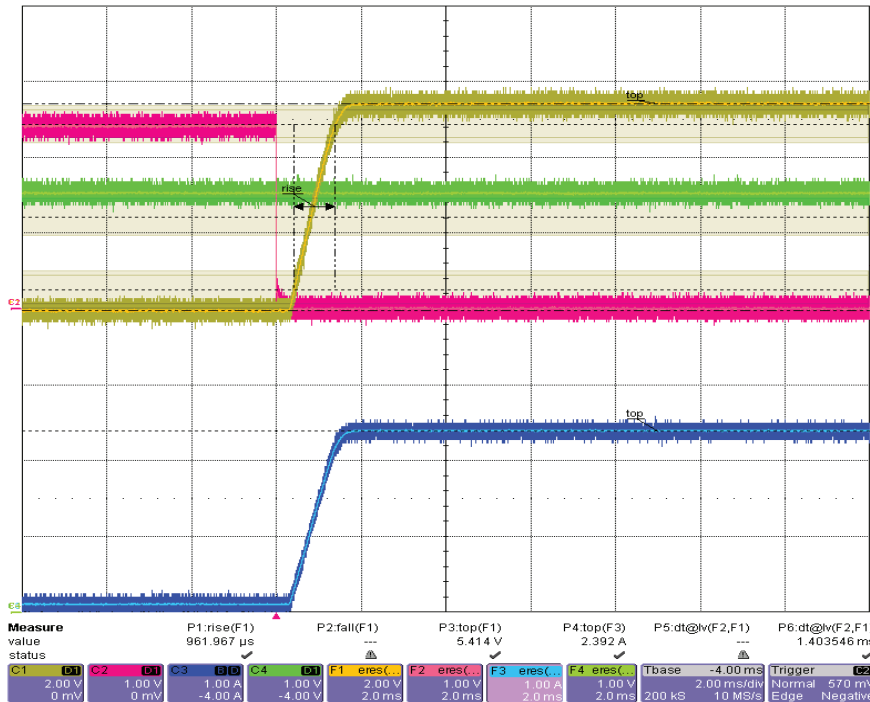



Enable Power Down

Input Voltage:5.5V
Output Load:2 Ohm

Yellow: Output Voltage
Port A
Red: Enable Voltage
Blue: Output Current
Green: Input Voltage Port
B

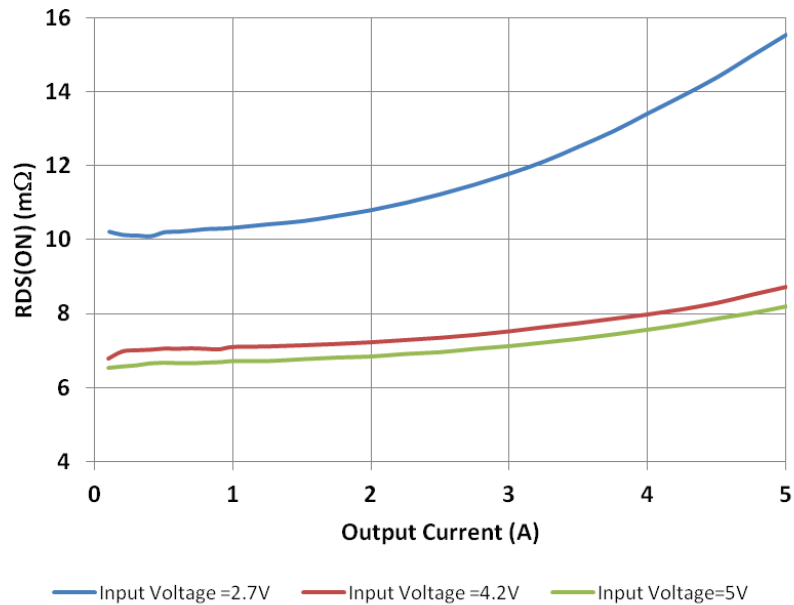
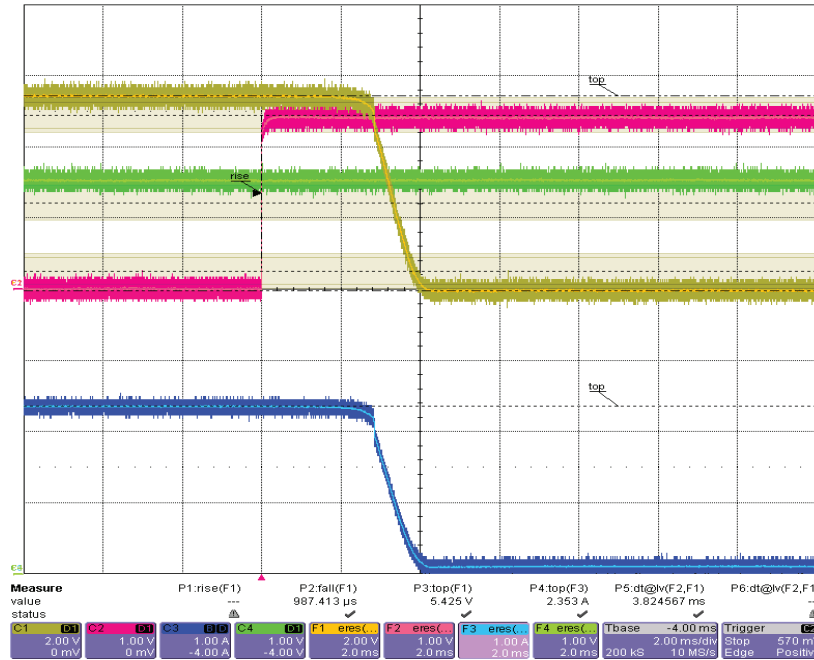

Vishay Siliconix maintains worldwide manufacturing capability. Products may be manufactured at one of several qualified locations. Reliability data for Silicon Technology and Package Reliability represent a composite of all qualified locations. For related documents such as package/tape drawings, part marking, and reliability data, see www.vishay.com/ppg?62935.

Looking for pricing, stock, or lifecycle information?

Click below to explore more details on WIN SOURCE:

 [View SIP32101EVB on WIN SOURCE](#)

 [Vishay Information](#)

Optimize Your Supply Chain with WIN SOURCE Solutions

-  Global Sourcing Solution
-  Obsolete Management
-  Cost Control Management
-  Shortage Management
-  Alternative Solution
-  Excess Inventory Management