



**THE DATASHEET OF
SP16160CH1RBKIT/NOPB**



SP16160CH1RB

High-IF Receiver Reference Design Board

LMH6517 + ADC16DV160 + LMK04031B

User's Guide

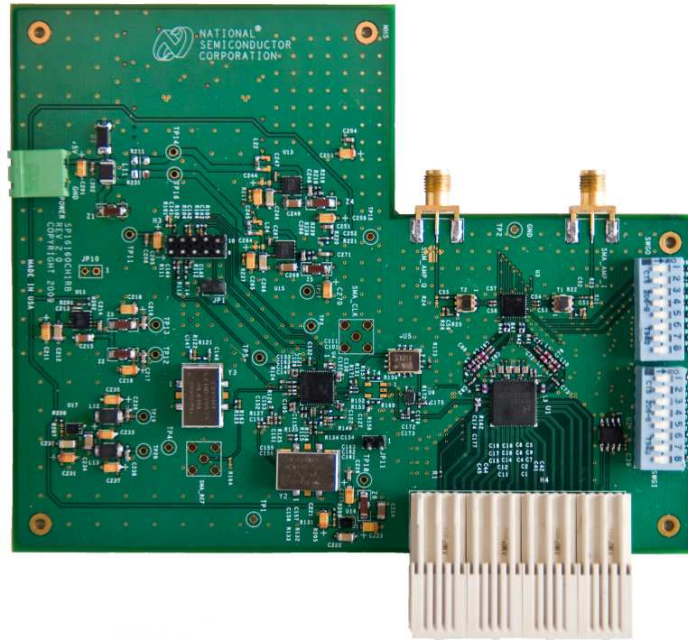

1.0 Reference Board Overview	2
2.0 Evaluation Kit Contents	4
3.0 System Description	4
4.0 Data Capture	5
5.0 Quick Start	5
6.0 Functional Description	7
7.0 System Performance	11
8.0 Device Configuration	13
9.0 Optional Hardware Configurations	17
10.0 Schematic	19
11.0 Layout	23
12.0 Bill of Materials	29

1.0 Reference Board Overview

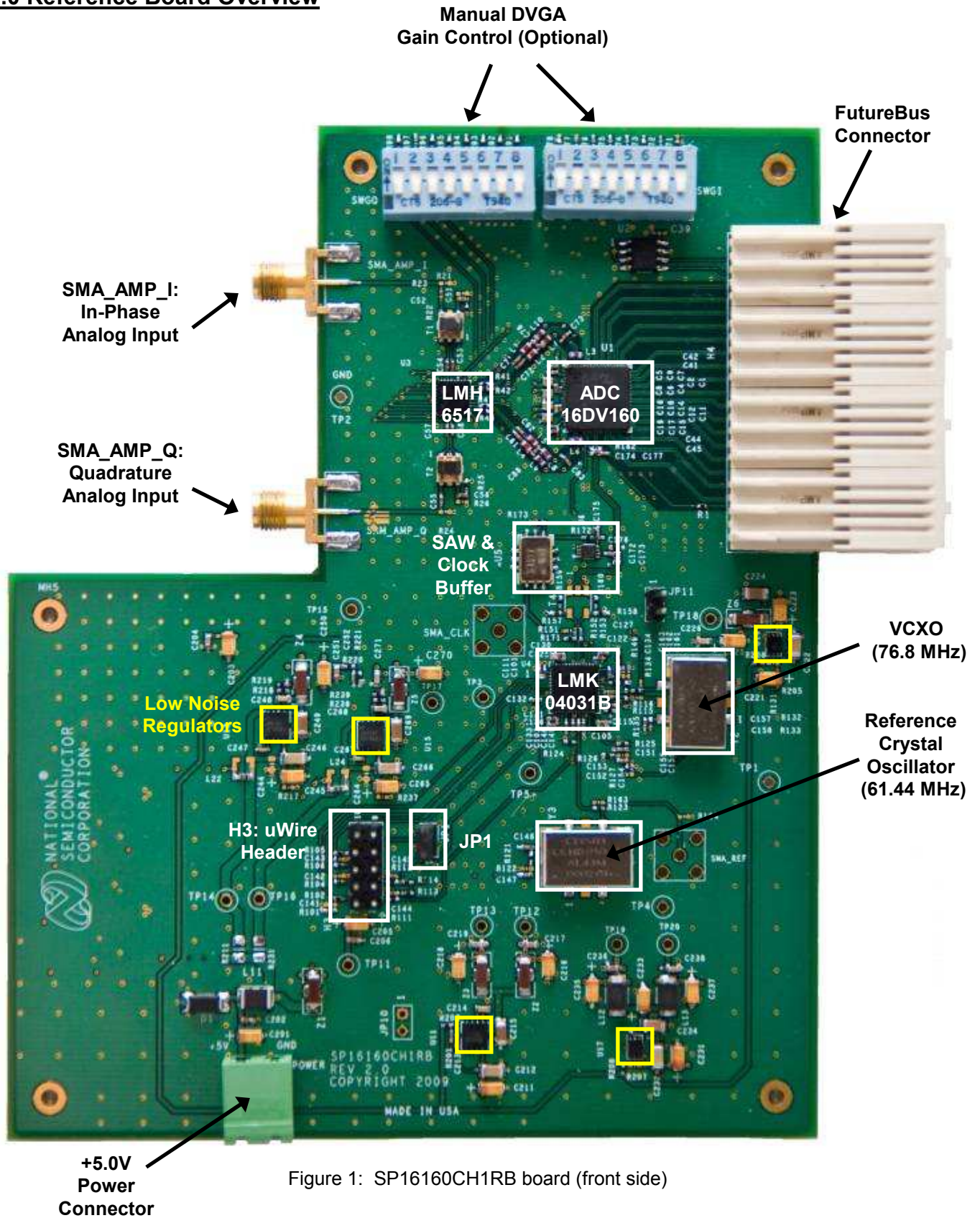

Figure 1: SP16160CH1RB board (front side)

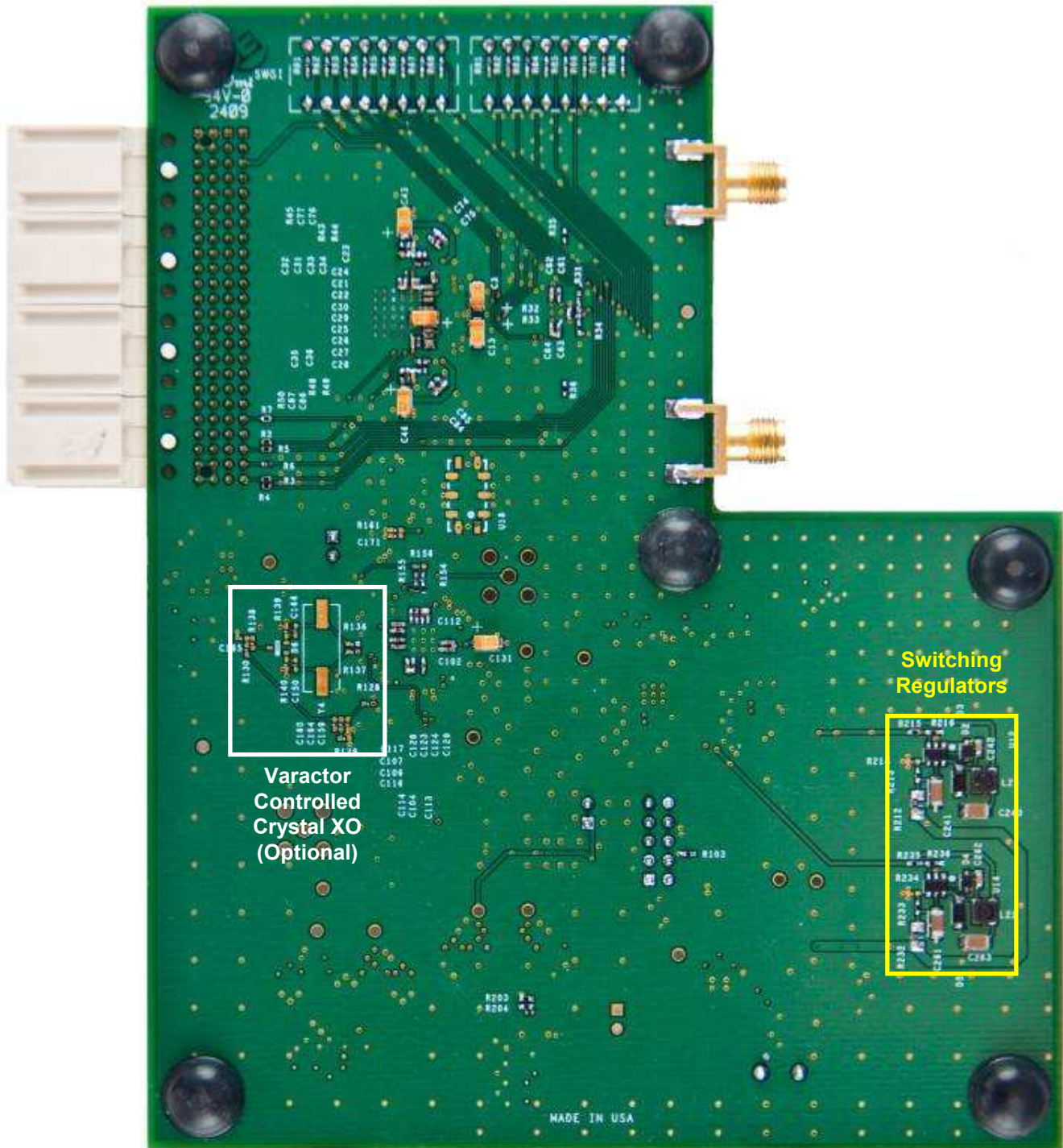

Figure 2: SP16160CH1RB board (back side)

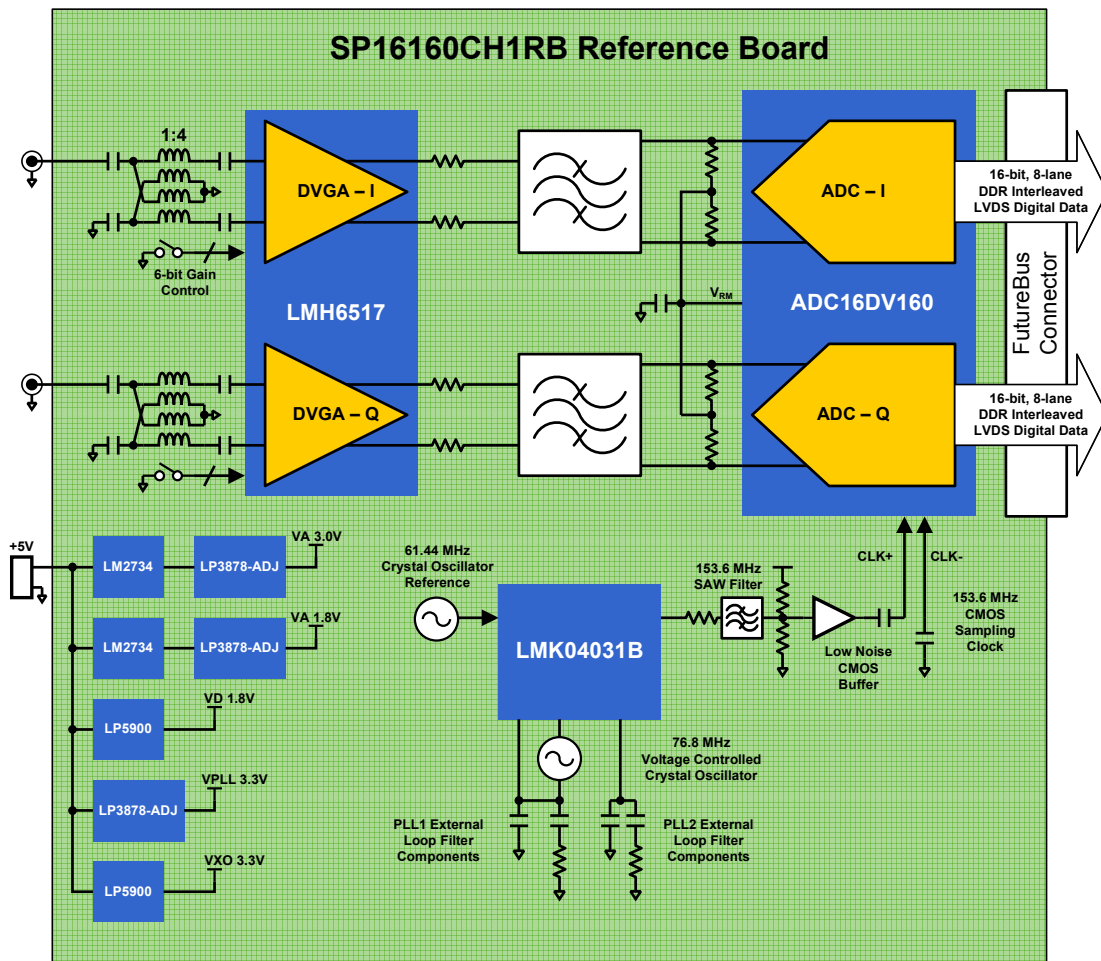

Figure 3: SP16160CH1RB block diagram

2.0 Evaluation Kit Contents

The SP16160CH1RB evaluation kit includes the following items:

- SP16160CH1RB reference design board
- PIC microcontroller board (ADC14PIC REV. A)

The SP16160CH1RB reference board is fully assembled for immediate evaluation. A PIC microcontroller board is included with the evaluation kit to properly configure the on-board clock solution.

The following items are required to evaluate the SP16160CH1RB but NOT included in the evaluation kit. See section 5.0 Quickstart for more information.

- Signal generator and connecting cables
- +5V, 1A power supply and cable
- Data capture hardware and analysis software

3.0 System Description

The SP16160CH1RB is a high IF receiver reference design board that utilizes the following components from National Semiconductor:

- **ADC16DV160** A dual channel, 16-bit, 160 MSPS (Megasamples-per-second) analog-to-digital converter (ADC) with parallel LVDS outputs.
- **LMH6517** A high performance, dual channel digitally controlled variable gain amplifier (DVGA) with a 31.5 dB gain range in 0.5 dB steps.
- **LMK04031B** A clock conditioning solution composed of a low-noise jitter cleaner, clock multiplier, and clock distribution stage.
- Several energy-efficient power management ICs including the **LM2734** switching regulator and the **LP3878-ADJ** and **LP5900** low drop-out (LDO) regulators.

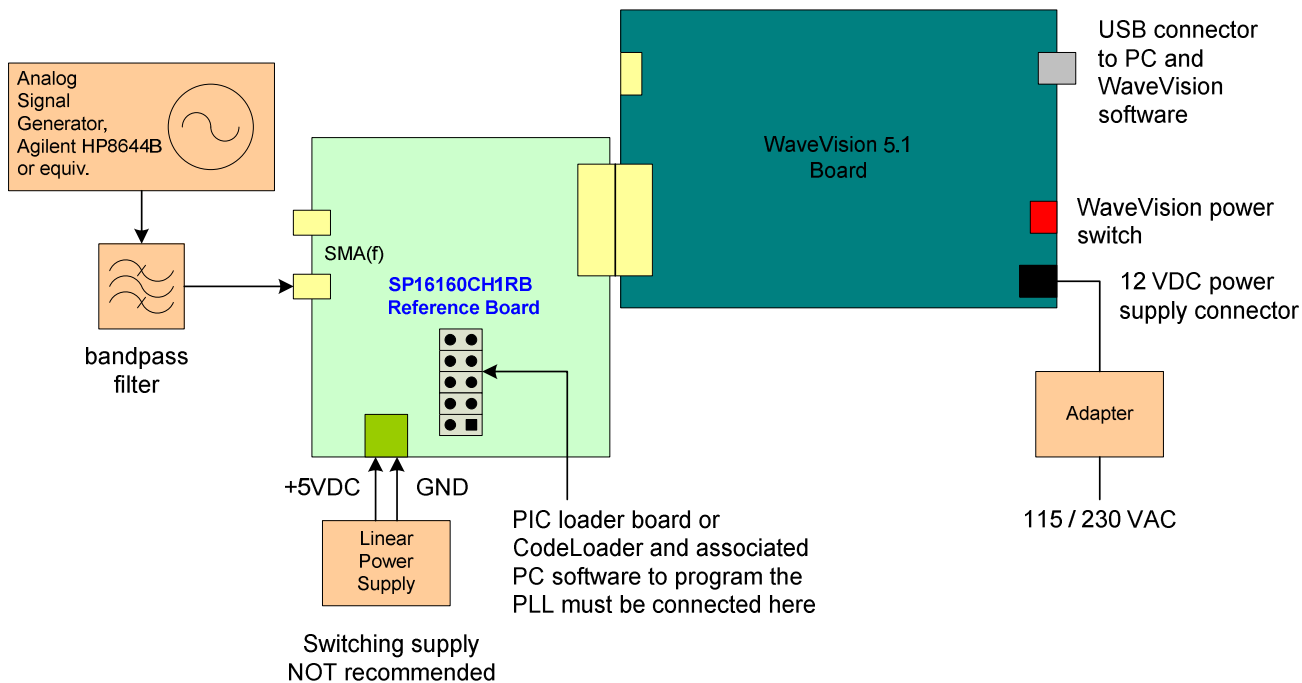

Figure 4: Connection diagram for the SP16160CH1RB board and WaveVision 5.1 data capture hardware

As shown in block diagram of Figure 3, this subsystem reference design provides single-to-differential conversion, digitally controlled gain, bandpass filtering of dual channel input signals and high dynamic range digitization. The low-noise optimized clock path provides a 153.6 MHz low-jitter, single-ended CMOS sampling clock for the ADC.

The measured system performance demonstrates an Nyquist band SNR of 72 dBFS for a -3 dBFS, 192 MHz input signal and SFDR greater than 85 dBFS for single tone input frequencies between 182 and 202 MHz and a sampling frequency of 153.6 MSPS.

This reference design enables immediate evaluation of a high dynamic range, high-IF sampling application such as a wireless communications sampling receiver subsystem.

4.0 Data Capture

The digital data from the SP16160CH1RB reference design board can be captured with a suitable instrument, such as a logic analyzer, or with National Semiconductor's WaveVision signal path data acquisition hardware and software platform. The SP16160CH1RB board is connected to the data acquisition hardware through the FutureBus connector (schematic reference designator H4).

The SP16160CH1RB is compatible with National Semiconductor's WaveVision 5.1 Signal Path Digital

Interface Board and associated WaveVision 5 software. Please note that the SP16160CH1RB board is not compatible with previous versions of the WaveVision hardware (WaveVision 4.x Digital Interface Boards).

The WaveVision hardware and software package allows fast and easy data acquisition and analysis. The WaveVision hardware connects to a host PC via a USB cable and is fully configured and controlled by the latest WaveVision software. The latest version of the WaveVision 5 software and information about the WaveVision 5.1 Signal Path Digital Interface hardware (part number: WAVEVSN BRD 5.1) are available through the National Semiconductor website at <http://www.national.com/analog/adc>.

5.0 Quick Start

5.1 WaveVision Software and Hardware Installation

- Begin by installing the latest version of WaveVision 5 and be sure to enable the update manager to keep up to date with the most current version. Do not start the WaveVision software application at this point.



The WaveVision software must be installed before connecting the WaveVision hardware.

- Connect the WaveVision 5.1 Digital Interface Board to your PC through the supplied USB cable and apply power to the WaveVision 5.1 board through the +12V AC-DC power adapter included in the WaveVision 5.1 hardware kit. The connection diagram is shown in Figure 4.

If this is the first time connecting a WaveVision 5.1 board to your PC, follow the on-screen instructions for installing the drivers for the hardware.

For more information on installing the WaveVision data acquisition hardware or software, please refer to the Quick Start Guide in the WaveVision User's Guide which can be found on the National Semiconductor website at http://www.national.com/appinfo/adc/evalboards_datacapture.html.

Please note that the SP16160CH1RB is only compatible with National Semiconductor's WaveVision 5.1 Digital Interface board.

5.2 Reference Board Jumper Positions

- Verify that the JP1 jumper is installed to provide power to the PIC microcontroller board. The PIC is used for programming the LMK04031B registers.



Remove JP1 if using CodeLoader to program the LMK04031B (see Section 8.2 of this guide).

5.3 Connecting Power and Signal Sources

- Connect the SP16160CH1RB reference board to the WaveVision 5.1 board through the FutureBus connector as shown in Figure 4. The SP16160CH1RB reference board should not be powered up, as the WaveVision hardware does not support hot-swapping of boards.
- Power up the WaveVision 5.1 board and connect it to the PC with a USB cable.
- Plug the PIC microcontroller board onto the dual-row header labeled "H3" as shown in Figure 5. Align the arrows on the two boards to ensure proper orientation. JP1 should have a jumper installed on the main board to provide power to the PIC microcontroller board. Lastly, flip the switches on the PIC microcontroller board to the following positions: Switch 1 = ON, Switch 2 = ON.
- Connect a 5.0V power supply capable of sourcing up to 1A to the green, 2-terminal power connector located along the side edge of the SP16160CH1RB board. This is shown in Figure 4. Ensure that the polarity of the wires going to the green power connector match the "+5V" and "GND" labels on the reference board. After the polarity is verified, turn on the 5V supply.

- Press the "RESET" button on the PIC microcontroller to load the register settings into the LMK04031B. The three LED's on the PIC microcontroller board will flash four times to indicate that the register bits have been sent to the LMK04031B. If the lights do not flash, ensure that JP1 is connected to supply power to the PIC board.
- Connect the signal source to the "SMA_AMP_I" SMA connector indicated in Figure 1. The recommended signal generators are the HP8644B (HP/Agilent) or the SMA100A (Rohde & Schwarz). A bandpass filter between the signal generator output and the SP16160CH1RB SMA connector is required to measure the true performance of the board. A Trilithic bandpass filter is recommended. See Figure 4.
- Set the signal source frequency to 190 MHz and the starting input amplitude to -15 dBm.
- Start the WaveVision software. The WaveVision software will automatically load the appropriate firmware to initialize data capture from the SP16160CH1RB. Allow the firmware file to finish downloading before continuing. When finished, the board should be ready to capture digital data.
- Capture the data and display the FFT of the captured data with the WaveVision software.

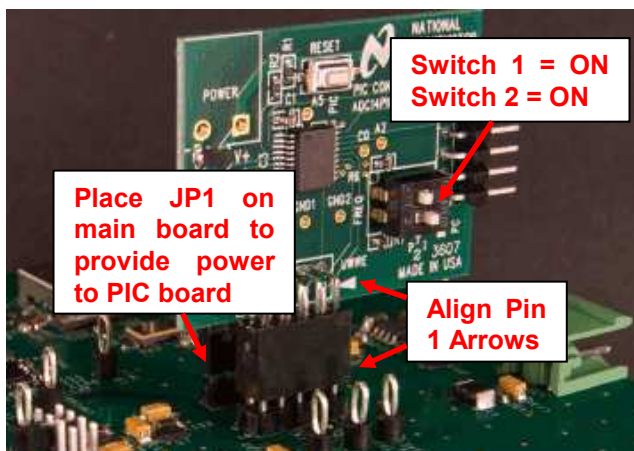

Figure 5: PIC microcontroller Board Connection and Configuration

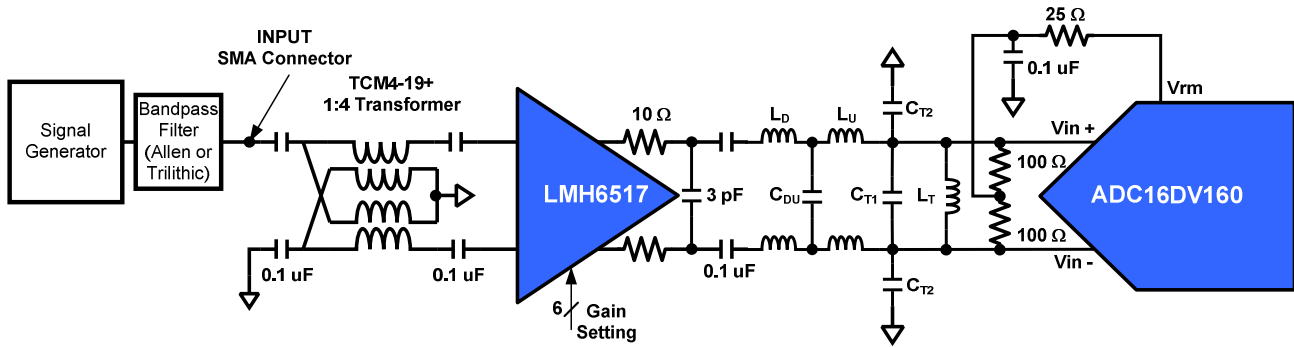

Figure 6: Single channel analog input signal path

6.0 Functional Description

6.1 Signal Path

The critical signal path of the SP16160CH1RB travels from the signal source input through a transformer, the DVGA, a bandpass filter, and then to the ADC. Circuit details are shown in Figure 6.

A transformer is necessary to match the 50 ohm impedance of the signal generator to the 200 ohm input impedance of the LMH6517. The 1:4 impedance ratio of the transformer provides ~6 dB of voltage gain at the input of the DVGA. AC coupling capacitors isolate the internal common-mode bias of the DVGA from the grounded center tap of the transformer.

The DVGA is composed of a ladder attenuator followed by a 22 dB, fixed-gain amplifier. The ladder has a 31.5 dB attenuation range in 0.5 dB steps and is controlled by a 6-bit internal register.

The T-matched bandpass anti-aliasing filter between the LMH6517 DVGA and the ADC16DV160 provides attenuation of amplifier distortion and noise. The SP16160CH1RB filter has been designed for an intermediate frequency (IF) of 192 MHz and a 20 MHz bandwidth.

Frequencies above the bandpass center have greater than 4th order roll-off (> 24dB/octave) with this filter topology whereas low frequencies have only a 1st order roll-off. This architecture can provide > 40 dB harmonic attenuation with minimal filter complexity and nearly 0 dB insertion loss to allow the DVGA to drive the ADC input to full scale without compressing at the supply rails. Ripple in the passband is easily kept below 1 dB. The equivalent noise bandwidth (ENBW) of this filter is approximately 44 MHz.

Filter component values for the circuit in Figure 6 are given in Table 1 and the normalized filter profile is shown in Figure 7. The load resistors of the filter are chosen to provide a low impedance input common-mode reference for the ADC and 0 dB voltage insertion

loss. The source resistors and 3 pF shunt capacitor at the DVGA output are necessary to maintain amplifier stability and provide an adequate passband profile.

The ADC samples the input signal at 153.6 MSPS, quantizes it to 16-bits, and outputs LVDS data. The full scale input range of the ADC is 2.4 V differential peak-to-peak ($V_{diff-PP}$) and must be fully utilized to maximize the SNR performance.

Table 1: Bandpass filter component values

Center Frequency [MHz]	BW [MHz]	L _D [nH]	L _U [nH]	C _{DU} [pF]	C _{T1} [pF]	C _{T2} [pF]	L _T [nH]
192	20	110	200	4	16	4	33

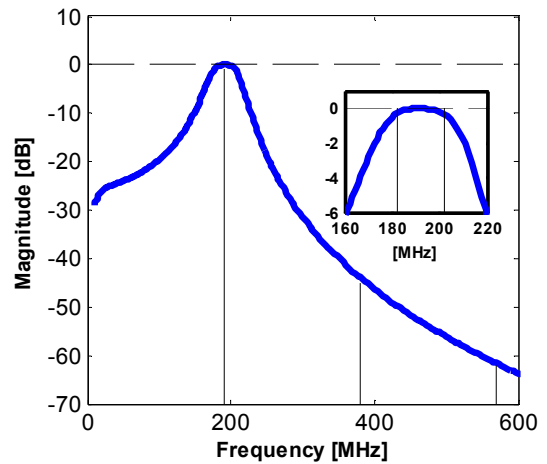

Figure 7: Bandpass filter profile centered at 192 MHz

A low noise signal generator such as the HP8644B (HP/Agilent) or SMA100A (Rohde & Schwarz) is recommended to drive the signal input of the SP16160CH1RB evaluation board. The output of the signal generator must be filtered to suppress the harmonic distortion and noise produced by the signal generator and to allow accurate measurement of the system's distortion performance. A tunable bandpass filter made by Trilithic (Indianapolis, IN) is

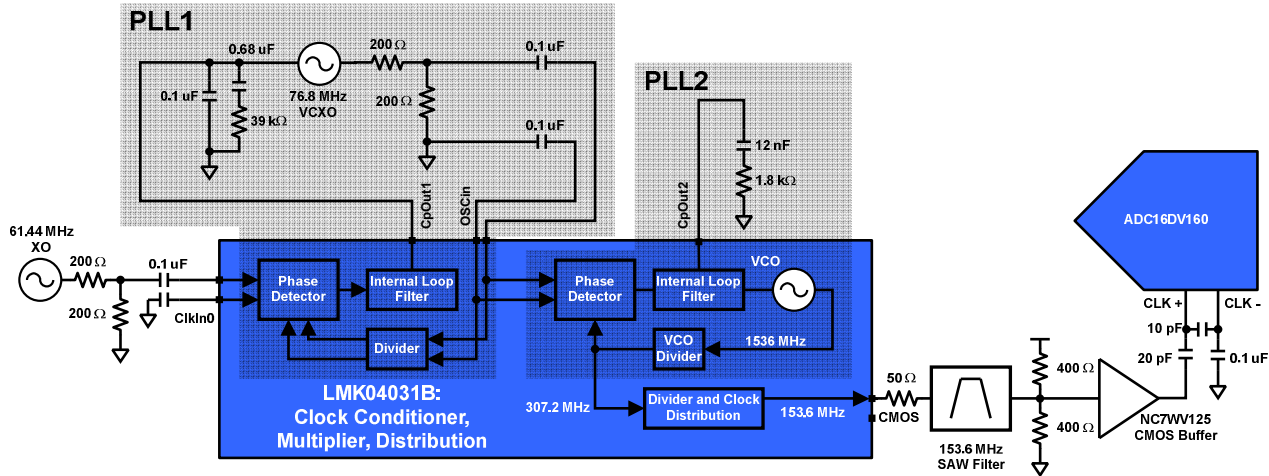

Figure 9: Sampling clock path of the SP16160CH1RB

recommended. Using only a lowpass filter is not recommended as the SNR performance is significantly degraded by the broad-band signal generator noise in the passband.

6.2 IF-Sampling Sub-System Frequency Plan

The SP16160CH1RB sub-samples the 192 MHz IF with a 153.6 MSPS clock so that the 20 MHz signal band aliases to the center of the first Nyquist zone at 38.4 MHz.

A large benefit of this plan is the placement of the second order harmonic, H2, completely out of the band of interest when it aliases. H3 cannot be excluded from the signal band and must be reduced in the system as much as possible. The frequency ranges of the H2 and H3 aliases are shown in Figure 8.

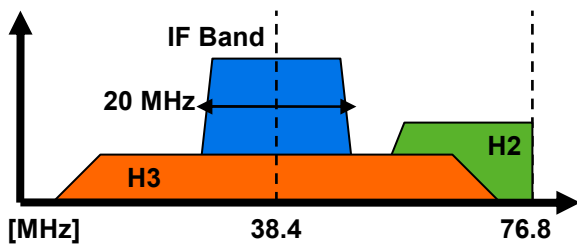

Figure 8: Frequency plan showing aliasing of the 192 MHz IF band, H2 band, and H3 band into the first Nyquist zone

6.3 ADC Reference

The SP16160CH1RB reference board is configured to use the internal 1.2V reference on the ADC16DV160. This is the recommended reference configuration for the ADC16DV160.

The ADC has an internal register option to reduce the reference voltage for improved distortion at the cost of reduced SNR. The register can be configured using the WaveVision 5 data capture platform.

6.4 Clock Path

The clock signal used to sample the analog input is generated using the LMK04031B. The LMK04031B is a low-jitter precision clock conditioner that consists of cascaded phase locked loops (PLLs), an internal voltage controlled oscillator (VCO) and a distribution stage. The first PLL locks an external voltage controlled crystal oscillator (VCXO) to an incoming reference clock and filters the phase noise of the reference. The output of the first PLL becomes the reference input to the second PLL stage which uses a VCO to multiply the external VCXO frequency. The VCO output is passed to the distribution stage which provides frequency division, buffering and conversion to a number of clock output formats including CMOS, LVPECL and LVDS.

For a lower cost implementation, the first PLL can also be configured to use an internal, low-noise oscillator circuit with an external crystal and varactor diode.

In the SP16160CH1RB system shown in Figure 9, the clock is generated with the LMK04031B by locking a 76.8 MHz VCXO (Crystek CVHD-950-76.8) to the 61.44 MHz reference oscillator, cleaning the phase noise, multiplying the VCXO to 1536 MHz and then dividing the frequency down to output a 153.6 MHz, single-ended CMOS clock. The external loop filter components for PLL1 and PLL2 are optimized for low jitter performance.

The single-ended CMOS clock signal from the LMK04031B is passed through a narrow bandwidth SAW filter and then buffered with a low-noise CMOS buffer to create a very low jitter, single-ended clock source at the CLK+ input of the ADC16DV160. Filtering

and buffering the clock reduces broadband white noise present on the clock output from the LMK04031B. Reducing the broadband noise is important because the noise present at the wideband clock input of the ADC convolves with the input signal during the sampling process and aliases back into the first Nyquist zone to degrade the SNR. A capacitive divider is then used to reduce the clock amplitude to within tolerable levels for the ADC.

6.5 Output Data

The dual channel, 16-bit digitized outputs from the SP16160CH1RB reference board consist of 38 lines that are arranged into 17 LVDS pairs. These 17 pairs of lines carry the 16-bit output data (16 pairs) and the DRDY output clock signal (1 pair) across the FutureBus connector on the edge of the reference board to the data capture hardware.

The data is clocked out of the ADC using the DRDY signal with a dual data rate (DDR) such that the even bits of both channels are available on the rising edge of DRDY while the odd bits are available on the falling edge.

Channel I data is available on the reference board at pins A5/B5 (MSB +/-) through A12/B12 (LSB +/-) of the FutureBus connector and Channel Q data is available at pins A14/B14 through A21/B21. The DRDY signal is at pins A13/B13.

Please see the SP16160CH1RB reference board schematic in Section 10.0 of this guide and the ADC16DV160 datasheet for further details.

6.6 Power requirements.

Power to the SP16160CH1RB evaluation board is supplied through the green power connector labeled "POWER" located along the side edge of the board. The power supply must be capable of sourcing +5V up to 1A. The SP16160CH1RB reference board draws approximately 800 mA when digitizing a full scale input.

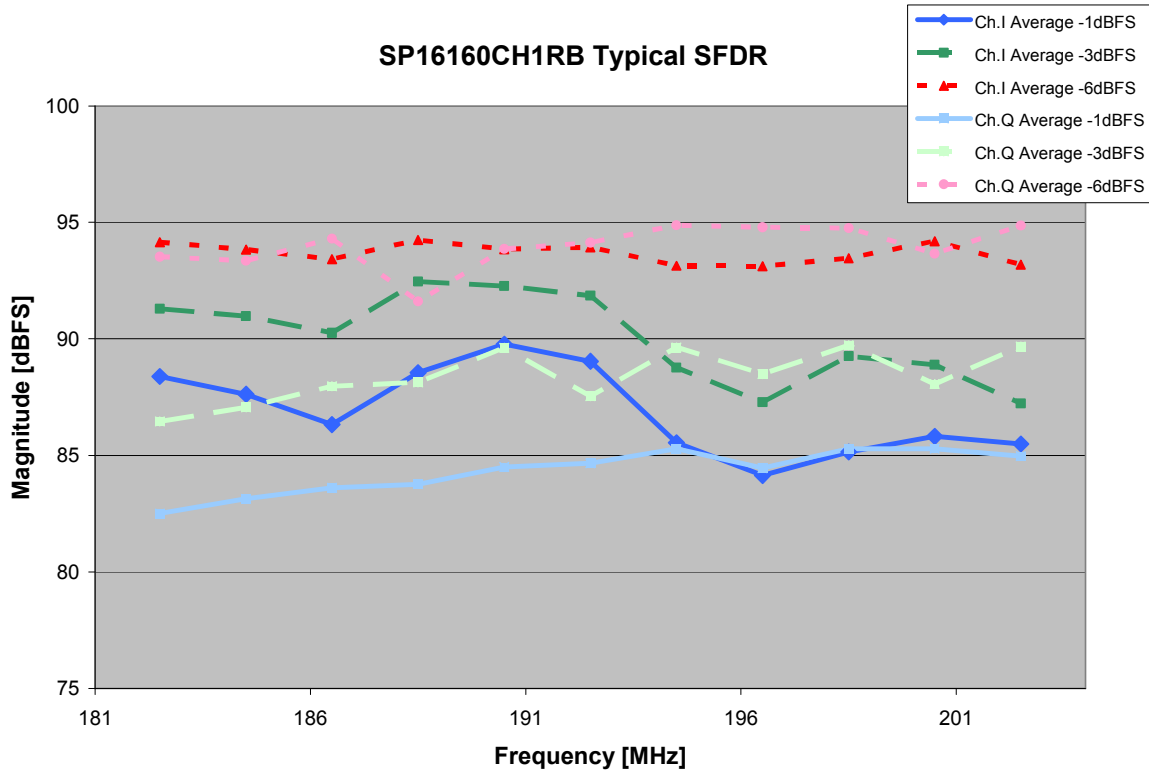

Figure 10: Typical SFDR performance vs. input signal frequency

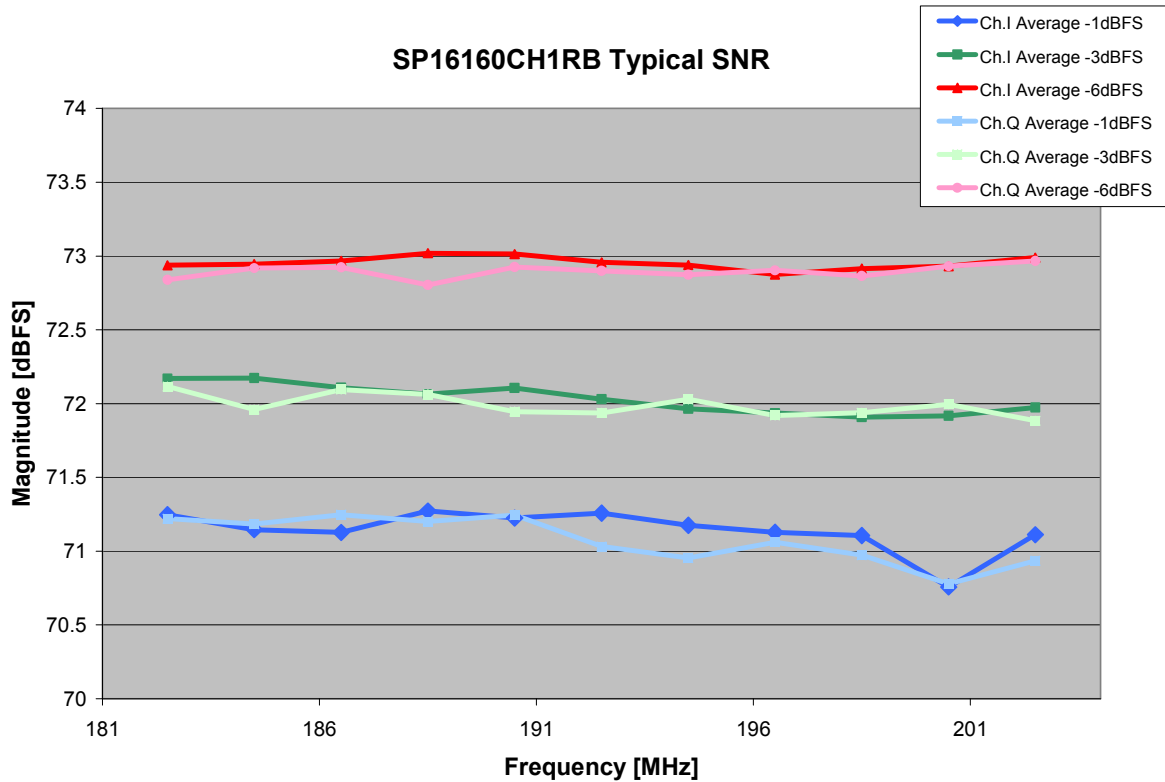

Figure 11: Typical Nyquist-band SNR performance vs. input signal frequency

7.0 System Performance

Figure 10 and Figure 11 show the typical SFDR and SNR performance respectively over frequency. The input signal is measured at -1, -3, and -6 dBFS and the sample rate is 153.6 MSPS. Figure 12 (a) and (b) show typical spectra for single and two-tone signals near 192 MHz.

7.1 Sources of Distortion

Harmonic distortion is introduced by the DVGA but does not appear at the ADC input due to the high attenuation of the anti-aliasing filter. Third-order intermodulation distortion falls into the filter bandpass and cannot be filtered out due to its proximity to the bandwidth of interest. Two-tone test measurements show that the third order products remain below 84 dBFS for a two-tone composite signal that has a 1 MHz tone separation and swings 90% of full scale (-1 dBFS, peak-to-peak).

The second- and third-order harmonic distortion (H2 and H3) that limits the SFDR of the system dominantly occurs at the interface to the ADC. Charge kickback from CMOS switches in the input stage of the ADC is a significant cause of the harmonic distortion and can be kept low with an empirical choice of capacitance in the filter's LC tank. Input signals near -1 dBFS amplitude result in an SFDR typically greater than 82 dBFS across the passband while -6 dBFS inputs typically have an SFDR of greater than 92 as shown in Figure 10.

7.2 Sources of Noise

The SNR of the SP16160CH1RB is limited by the thermal noise in the DVGA, thermal noise in the ADC, and the jitter on the sampling clock.

Thermal noise in the ADC sets the hard SNR limit in the system. An ideal 16-bit ADC is capable of a 98 dBFS SNR if quantization noise is the only contributor. Additional noise in the ADC16DV160 limits the small signal SNR to 78 dBFS and large signal SNR to 76.5 for a 192 MHz signal.

The signal bandwidth of the anti-aliasing filter is 20 MHz, considered here as the bandwidth with 0.5 dB ripple, but the effective noise bandwidth is 44 MHz due to the gradual roll-off of the filter profile. Noise from the DVGA passes through the filter bandpass to contribute to the total noise of the system. With the LMH6517 output noise density of 22 nV/sqrt(Hz) at 192 MHz and a 1 dB insertion loss through a filter with a 44 MHz ENBW, the small signal SNR due to the DVGA noise (SNR_{DVGA}) is 76.3 dBFS. The SNR_{DVGA} can be improved using a filter with a narrower effective noise bandwidth. It can also be improved by increasing the

insertion loss of the filter but will result in worse intermodulation distortion.

Jitter plays a role in limiting the SNR for large signal inputs. A 192 MHz, -1 dBFS input signal yields phase noise that results in an SNR, due to jitter (SNR_{Jitter}), of ~75 dBFS. This SNR_{Jitter} performance suggests a total clock jitter of less than 200 fs.

Combining the noise sources from the ADC, DVGA, and clock results in the total SNR (SNR_T) of 71 dBFS for a -1 dBFS input signal as shown in Figure 11. SNR_T also improves for lower DVGA gain settings due to a reduction in DVGA noise.

7.3 Wireless Base-Station Specific Performance

Base-station applications are concerned with maximizing the sensitivity in a certain channel bandwidth which can be limited by noise and spurs that appear in the channel.

Blocking signals that appear close in frequency to the channel not only limit the ability of the DVGA to apply gain to the signal, but also contribute more noise to the channel due to the phase noise skirt and the higher broadband phase noise level that accompanies large signals. To prevent overloading the ADC, a receiver's automation gain control (AGC) loop will keep the blocking signal at a reasonable level such as -4 dBFS.

Assuming a GSM-type channel bandwidth of 200 kHz and a -4 dBFS blocking signal that is 800 kHz from the channel center, the SP16160CH1RB achieves a SNR of 94 dBFS in the channel. In the absence of a blocking signal, the system achieves a channel SNR of greater than 99 dBFS.

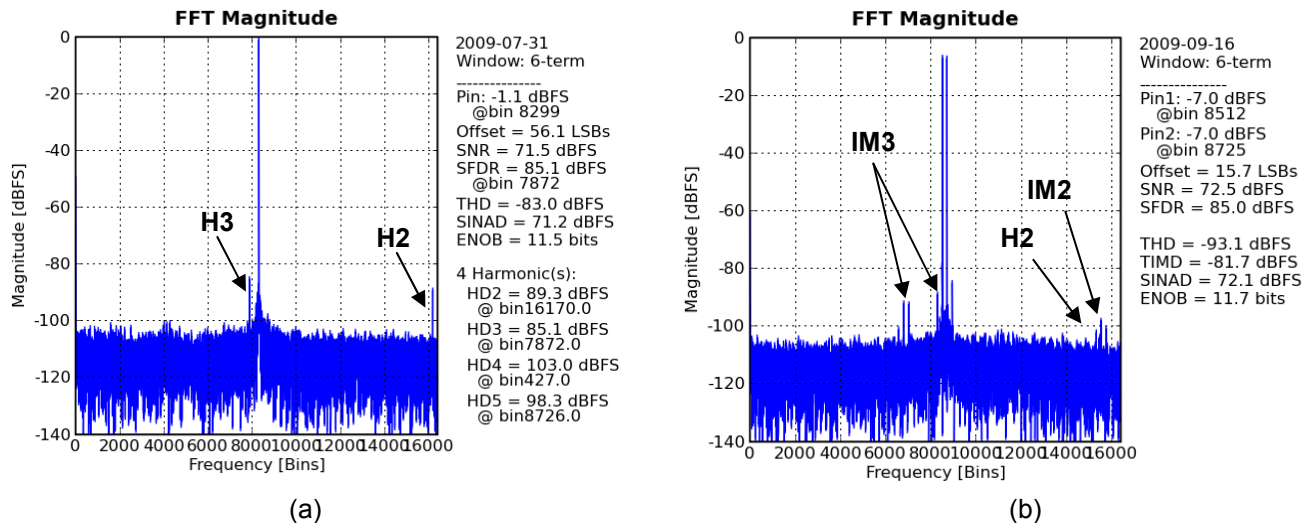

Figure 12: Typical FFT plot for a (a) 192 MHz, -1 dBFS input signal and (b) 194 MHz two-tone composite signal with 1 MHz spacing and -7 dBFS tones

8.0 Device Configuration

8.1 ADC16DV160 and LMH6517 Programming

The ADC16DV160 and LMH6517 are both programmable via a shared serial programming interface (SPI) bus that is accessible on the FutureBus connector. Writing to a device is handled with individual chip selects and is transparent to the user when using the WaveVision 5 capture platform and software.

Registers are programmed via the Registers tab in the WaveVision 5 software as shown in Figure 13 and Figure 14. After the reference board is been identified by the software, the Registers tab appears on the right-hand side of the window. Opening the tab reveals options for modifying the individual registers with high-level nomenclature.

ADC Device Registers (Figure 13)

- **Operation Mode:** Changes the operation of the ADC from normal operation to sleep, power-down, or fixed pattern modes.
- **Data Format:** Selects the output data format as Offset Binary or 2's Complement.
- **Full Scale Reference Voltage:** Varies the reference range of the ADC from 2.4 Vpp to 1.0 Vpp.
- **Sample Phase:** Selects the sampling edge of the clock.
- **Clock Divider:** Sets the internal clock to be divided by 1 or 2.
- **Output Clock Phase:** Varies the phase offset of the output data clock.

LMH Device Registers (Figure 14)

- **Ch. A/B Enable:** Enables or disables the DVGA output stage.
- **DVGA A/B Attenuation (bits):** Varies the attenuation of the ladder attenuator from 0 dB (value = 0) to 31.5 dB (value = 64).

The ADC16DV160 can only be programmed via SPI but the LMH6517 can operate in multiple modes. These modes include a Serial Mode in which the device is programmed via SPI, Parallel Mode in which the gain of the DVGA is controlled by manual switches, and Pulse Mode. The SP16160CH1RB is factory configured for Serial Mode but can be modified to operate in Parallel Mode. Pulse Mode is not supported on the SP16160CH1RB. Refer to the Optional Configurations section for more information.

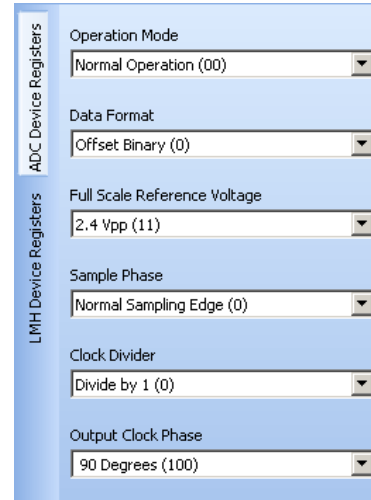

Figure 13: ADC16DV160 Registers tab in the WaveVision 5 software (Default)

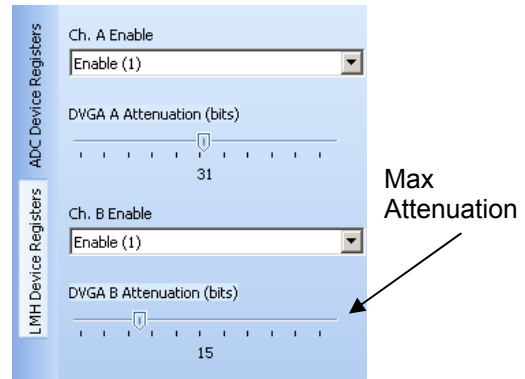

Figure 14: LMH6517 Registers tab in the WaveVision 5 software

8.2 LMK04031B Programming

The LMK04031B, which provides the sample clock for the ADC, must be configured correctly for the desired clock frequency. Programming can be accomplished by two methods.

The first method is to attach a small PIC-based module that is included in this evaluation kit. This module is plugged onto the 10-pin uWire header labeled "H3" as described in section 5.3 of this user's guide. If this module is used, the JP1 jumper must be installed to provide power from the main board to the PIC module. The PIC module will program the LMK04031B to output a 153.6 MHz single ended CMOS signal.

The second method for programming the LMK04031B uses the 10-pin uWire header to connect the LMK04031B's serial programming interface (DATA, CLK, LE) to a PC. To use this programming interface, a special parallel port (LPT) cable supplied by National Semiconductor allows the device to be directly

programmed with a PC using National Semiconductor's CodeLoader software. The serial programming interface can also be programmed over the USB port of the PC. To program the LMK04031B through the USB port, a separate interface board is available from National Semiconductor.

See http://www.national.com/appinfo/interface/clk_conditions.html to download CodeLoader, obtain a user's guide and to order any necessary hardware such as programming cables or USB interface boards.

! Remove JP1 if using CodeLoader to program the LMK04031B.

The procedure for programming the LMK04031B through National's CodeLoader software and special parallel port cable is described here if the user intends to program the SP16160CH1RB reference board for sampling rates other than 153.6 MSPS. Please note that the achievable sample rates are limited by the 61.44 MHz reference crystal oscillator and the 76.8 MHz VCXO if they are used. Hardware changes are also necessary to modify the clock path from the

standard 153.6 MHz path. Some output frequencies may also require loop filter changes for optimal jitter performance. In the default hardware configuration, 153.6 MHz is the only possible clock frequency due to the narrowband SAW filter in the clock path.

Figure 17 through Figure 25 illustrate each CodeLoader configuration screen and its contents used to properly program the LMK04031B Clock Conditioner through either a parallel port or USB PC interface and appropriate cable. These configuration screens are for programming the LMK04031B to output 153.6 MHz at CLKout2, which is the same output produced by using the PIC-module included in this evaluation kit.

Before programming the device, it is important that the LMK04031B go through a proper reset cycle. Check and then uncheck the RESET checkbox in the *Bits/Pins* tab in Figure 18 to accomplish the reset. Then configure the CodeLoader software according to the following figures and select *Load Device* from the *Keyboard Controls* file menu to program the device.

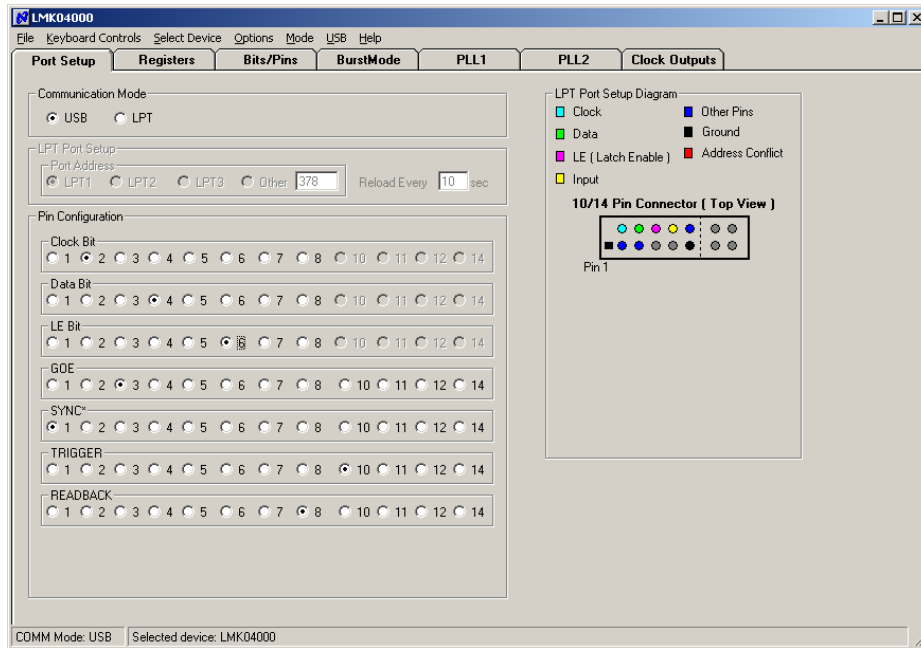

Figure 15: LMK04031B CodeLoader software communication port setup for programming

! The user may be required to select a different LPT port that is compatible with the capabilities of the PC being used to program the device. Using the USB port requires a separate interface board, available from National Semiconductor.

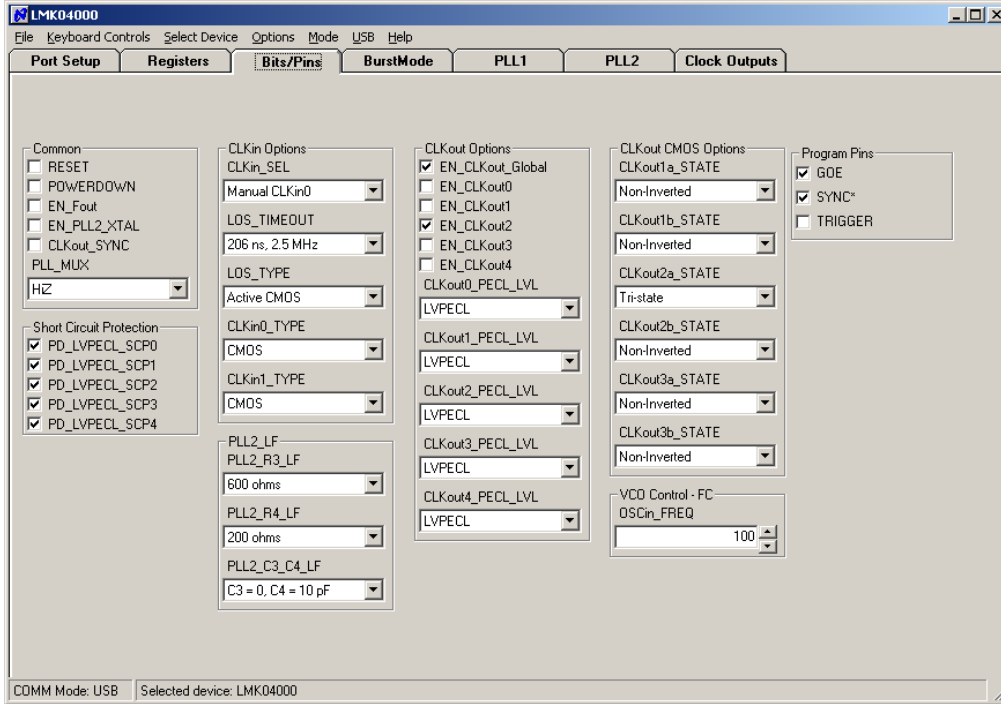

Figure 16: LMK04031 CodeLoader configuration, Bits/Pins tab.

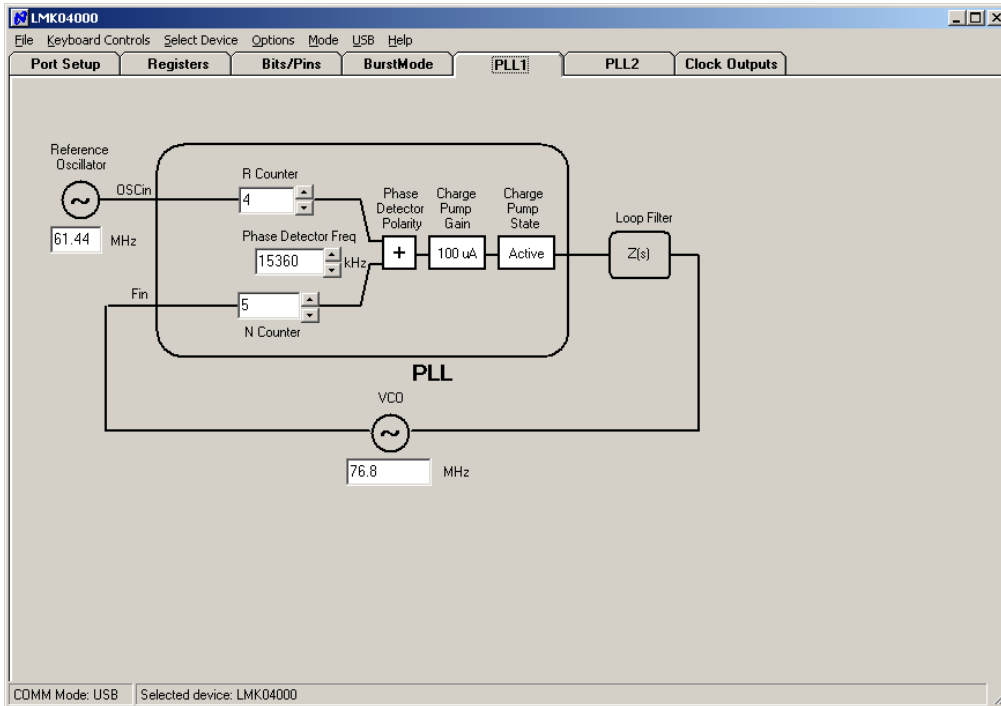

Figure 17: LMK04031B CodeLoader configuration, PLL1 tab.

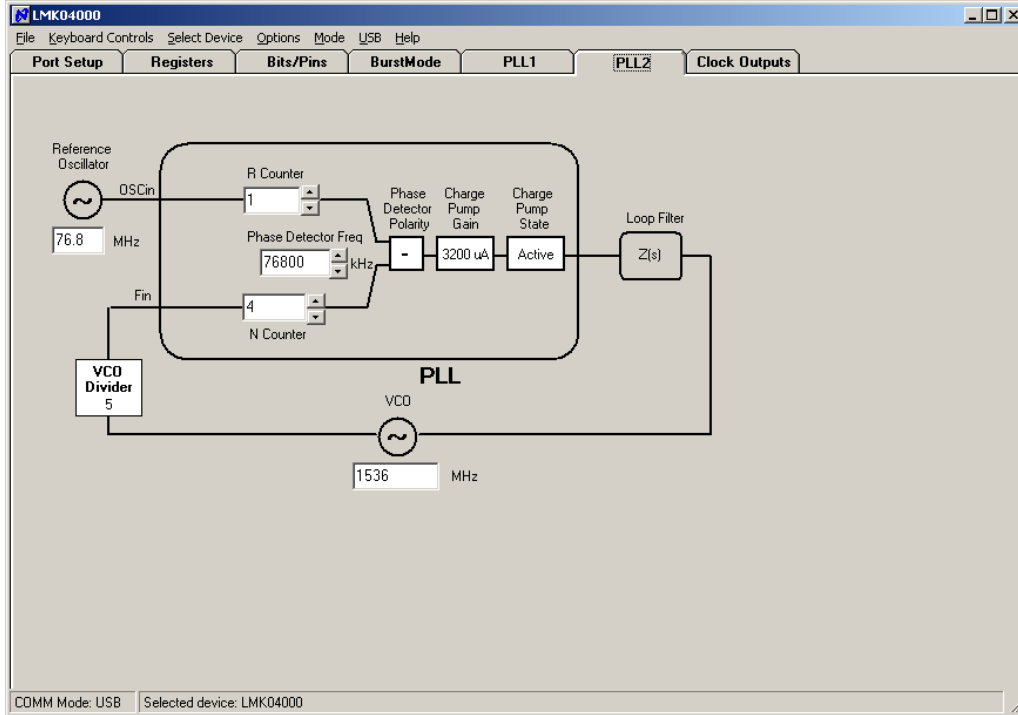

Figure 18: LMK04031B CodeLoader configuration, PLL2 tab.



Using PLL parameter values different from the values shown in Figure 17 and Figure 18 may result in degraded performance of the reference board.

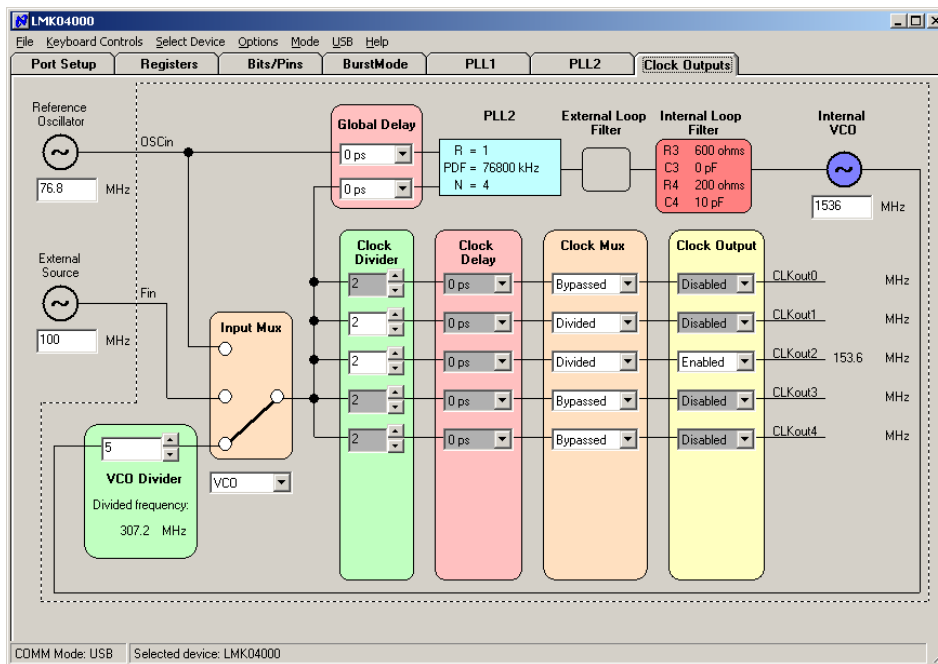

Figure 19: LMK04031B CodeLoader configuration, Clock Outputs tab.



The LMK04031B clock outputs are not easily accessible on the SP16160CH1RB reference board. See http://www.national.com/appinfo/interface/clk_conditioners.html for information on acquiring the LMK04031B Evaluation board that provides full access to all clock outputs on the LMK04031B.

9.0 Optional Hardware Configurations

Some optional hardware configurations are available on the SP16160CH1RB to evaluate the sub-system with different specified parameters and controls.

9.1 DVGA Gain DIP Switches

The SP16160CH1RB board is factory configured for programmable control of the DVGA gain via the SPI bus that is accessible on the FutureBus connector H4. 8-position DIP switches can be installed in the case that manual control of the gain is desired. The following changes must be made to the reference board to control the DVGA gain with switches. Table 2 gives the functions of the individual switches.

- Remove R71-R78 and R91-R98.
- Populate R61-R68 and R81-R88 with 10k ohm, 0402 resistors.
- Populate R71-R78 and R91-R98 with 20k ohm, 0402 resistors.
- Populate SWI and SWQ with 8-position, 10 mil spaced DIP switches. Note the orientation of the switch ON position in Figure 20.
- Remove R32. Populate R31 and R32 with 11k and 24k ohm, 0402 resistors respectively. These footprints are located on the back of the board under the DVGA.
- Remove resistors R4-R7 located on the back side by the FutureBus Connector.

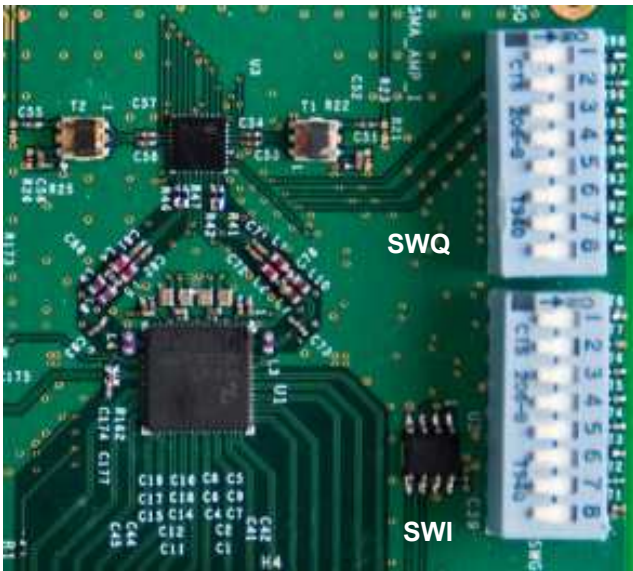

Figure 20: Orientation of the DIP switches that control the DVGA gain

Part	Sw #	Description
SWQ (Controls Q-Channel DVGA)	1	Latch (active high)
	2	DVGA Enable (active high)
	3	Gain[0] (LSB)
	4	Gain[1]
	5	Gain[2]
	6	Gain[3]
	7	Gain[4]
	8	Gain[5] (MSB, active high)
SWI (Controls I-Channel DVGA)	1	Gain[5] (MSB, active high)
	2	Gain[4]
	3	Gain[3]
	4	Gain[2]
	5	Gain[1]
	6	Gain[0] (LSB)
	7	DVGA Enable (active high)
	8	Latch (active high)

Table 2: Function of optional DVGA DIP switches

9.2 Sampling Clock Options

Utilizing the SAW filter and CMOS buffer with a single-ended CMOS clock optimizes the clock path for minimal jitter. There are additional available clocking schemes as listed below. Each non-default option requires hardware and software modification of the reference board.

1. External signal generator clock source
2. Single Ended CMOS with SAW and Buffer (Default configuration)
3. Differential LVPECL
4. Differential CMOS

The clock options above are listed in order from potentially least jitter (#1) to most jitter (#4).

Perform the following changes to modify the board for a **153.6 MHz differential LVPECL clock**:

- Remove R171, C174, C176 and C177
- Populate R154, R155, R159, and R160 with 0 ohm, 0402 resistors
- Populate R157 and R158 with 121 ohm, 0402 resistors
- Populate C172 and C173 with 0.1uF, 0402 capacitors

- Program the LMK04031B with the PIC Loader board set with Switch 1 = ON, Switch 2 = OFF

Perform the following changes to modify the board for a **differential CMOS clock**:

- Remove R171, C174, C176 and C177
- Populate R152, R153, R159 and R160 with 0 ohm, 0402 resistors
- Populate C172 and C173 with 0.1uF, 0402 capacitors
- This mode requires programming the LMK04031B via the CodeLoader software

Perform the following changes to modify the board for an **External signal generator clock source**:

- Remove R171, C174, C176 and C177
- Populate R151 and R158 with 0 ohm, 0402 resistors
- Populate T4 with a MA/COM MABA007159 or equivalent transformer
- Populate C172 and C173 with 20pF, 0402 capacitors
- Populate C174 with a 5 pF, 0402 capacitor
- Populate SMA_CLK with a SMA connector
- Provide a low-jitter, +18 dBm sinusoidal signal through a bandpass filter.

9.3 Varactor Controlled Crystal Oscillator

Very low-jitter clock performance is in-part achieved by using low noise oscillators for the frequency reference and VCXO. The reference board comes standard with Crystek CCHD-950 and CVHD-950 model oscillator modules that achieve low noise performance with -162 dBc/Hz broadband phase noise. Low phase noise comes with an associated high cost.

A lower cost solution is achieved for this reference board design with a varactor controlled crystal at the expense of lower noise performance at high input signal frequencies due to jitter. This circuit can be installed on the back side of the board to replace the VCXO module.

Please contact National Semiconductor for more information on configuring the reference board if this option is desired.

9.4 Bypassed Switching Regulators

LM2734 Switching regulators are utilized in this reference board design to minimize LDO regulator losses for the high current ADC supplies.

Noise on the supplies, especially the sensitive 1.8 V analog supply to the ADC, can cause a performance degradation in the form of small spurs offset ~500 kHz from a large input tone as shown in Figure 21. These spurs may be insignificant in many applications but can be reduced further if needed by reducing the supply ripple at the output of the switching regulators or eliminated completely by bypassing the switching regulators.

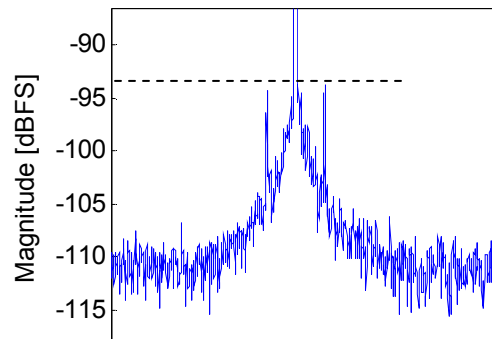

Figure 22: The on-board switching regulators can cause small spurious tones offset ~500 kHz from a large input signal

Bypassing the switching regulators reduces the noise on the ADC supplies at the expense of expending more power in the LDO regulators. Perform the following changes to bypass the switching regulators.

- Remove the resistor jumpers on L22 and L24.
- Remove R212 and R232.
- Populate R211 and R231 with 0805 0 ohm resistors.

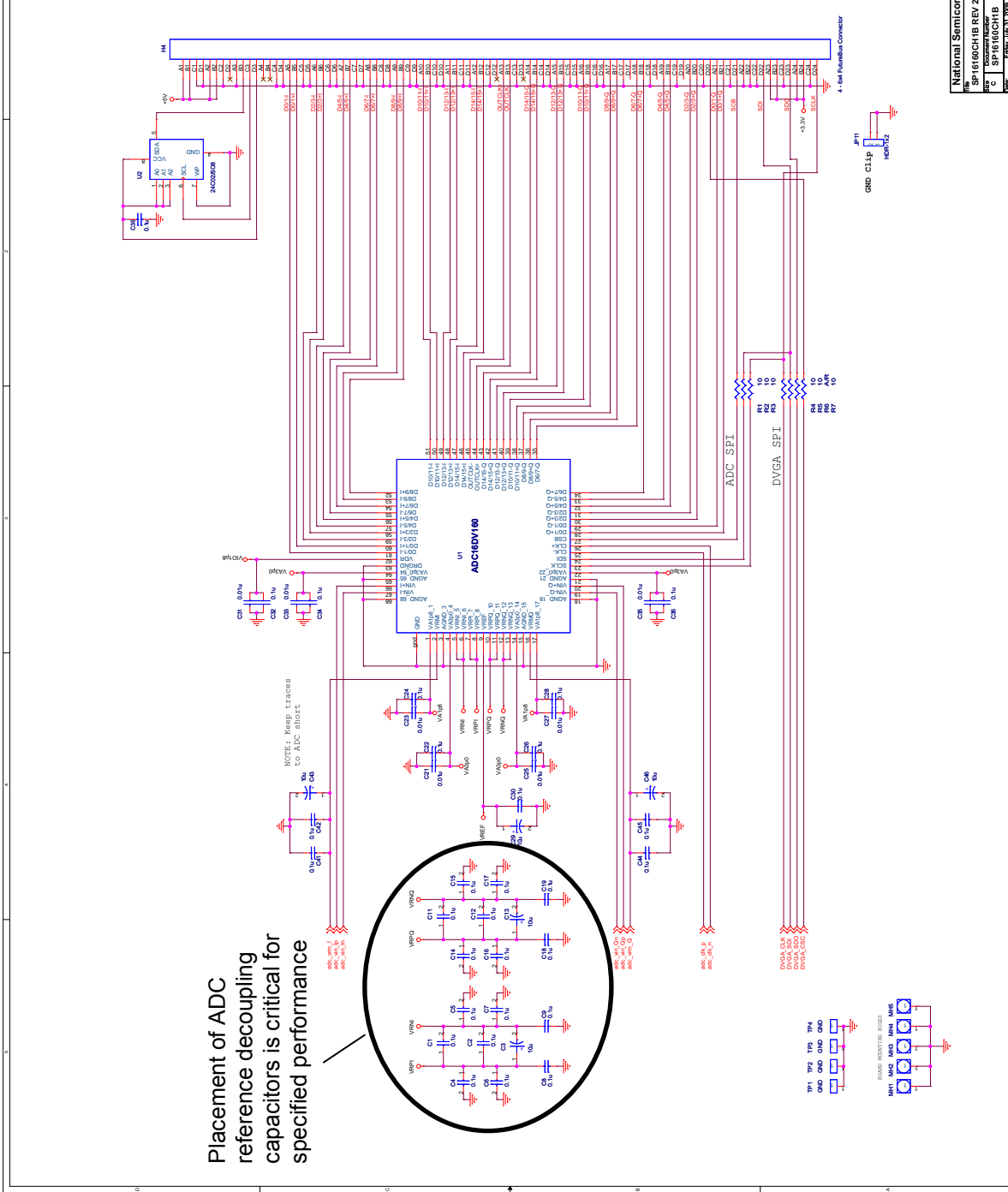

Figure 23: ADC16DV160 Circuit and FutureBus Connector

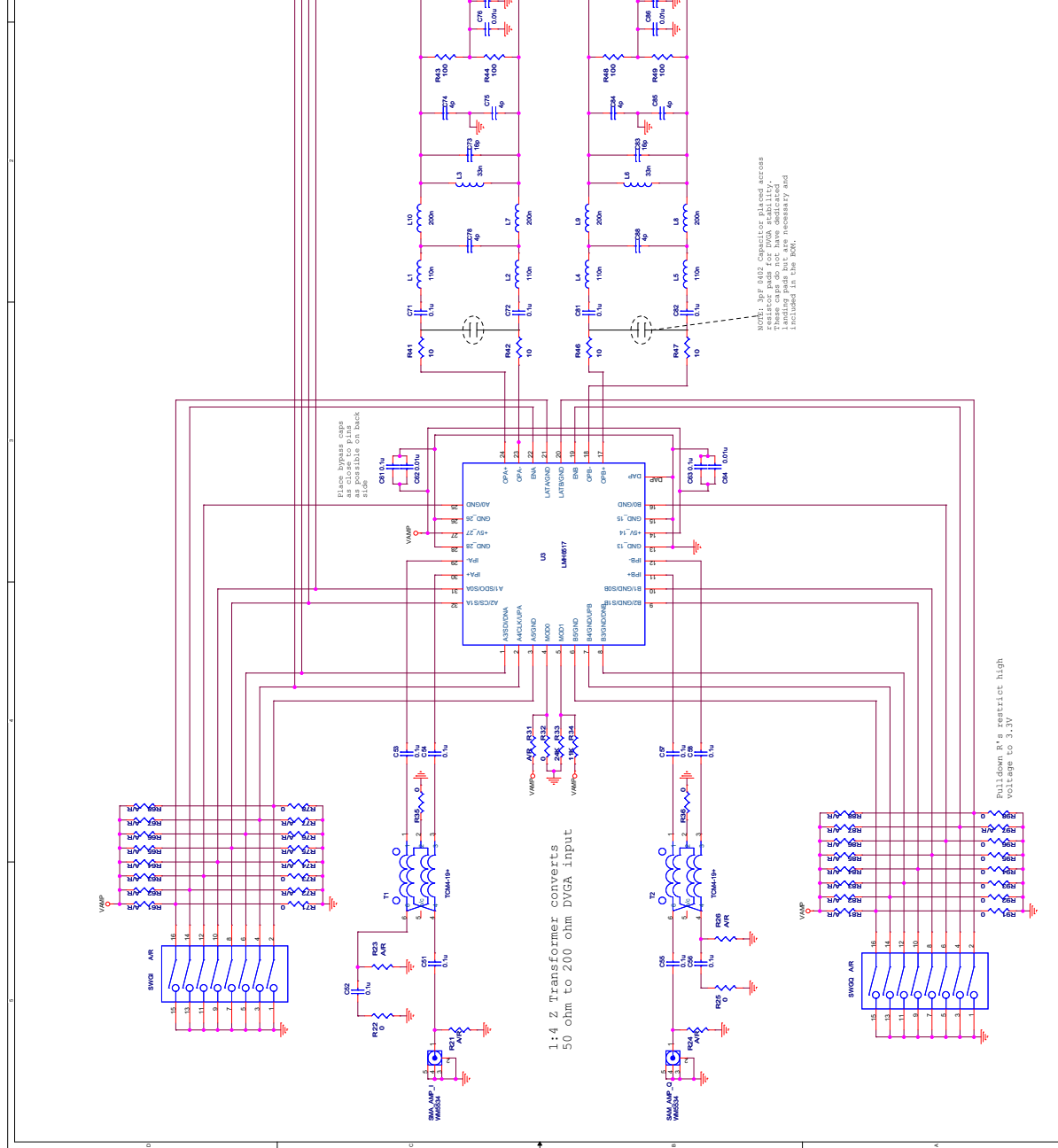

Figure 24: LMH6517 DVGA Circuit

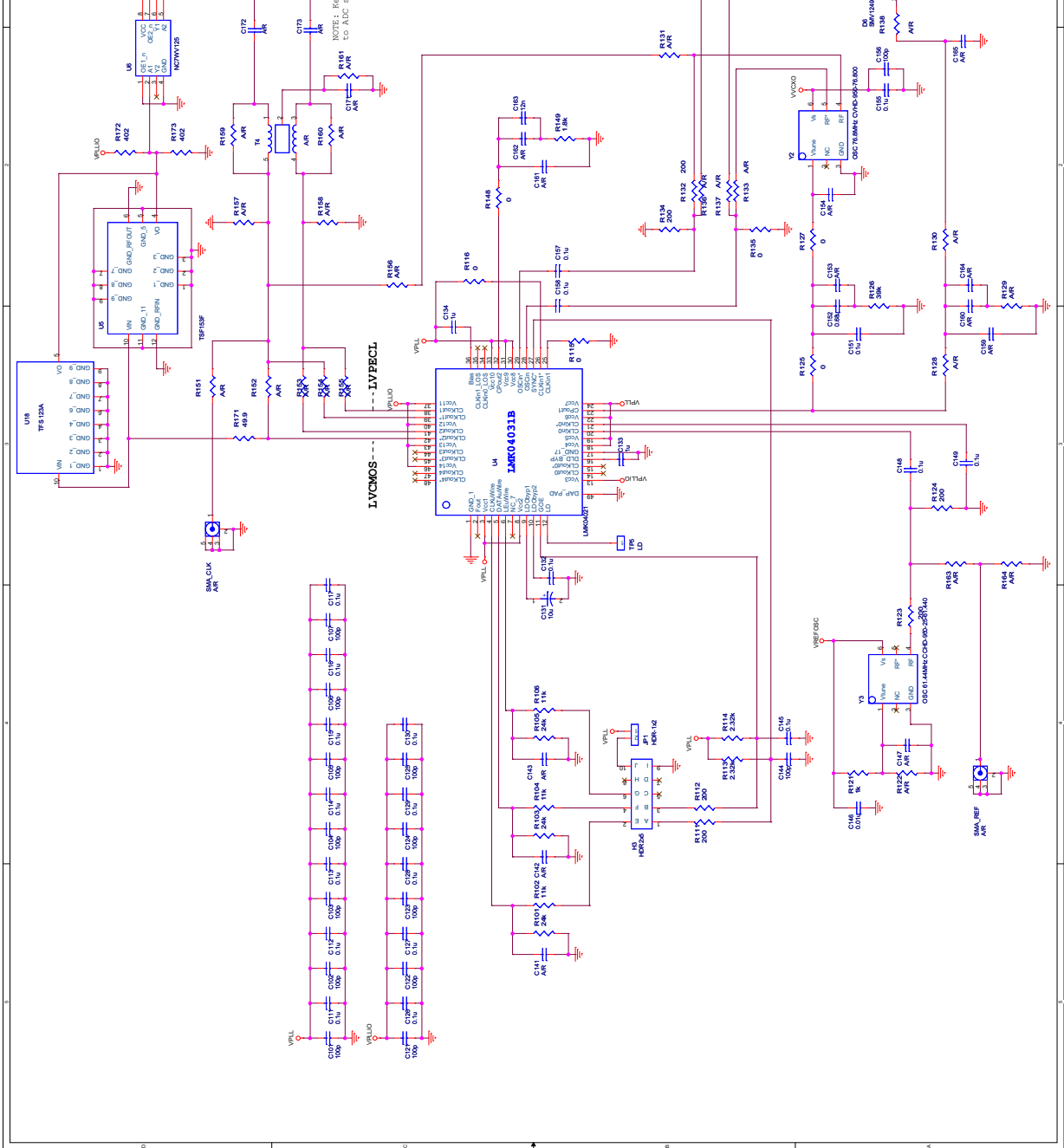

Figure 25: LMK04031B Clock Circuit

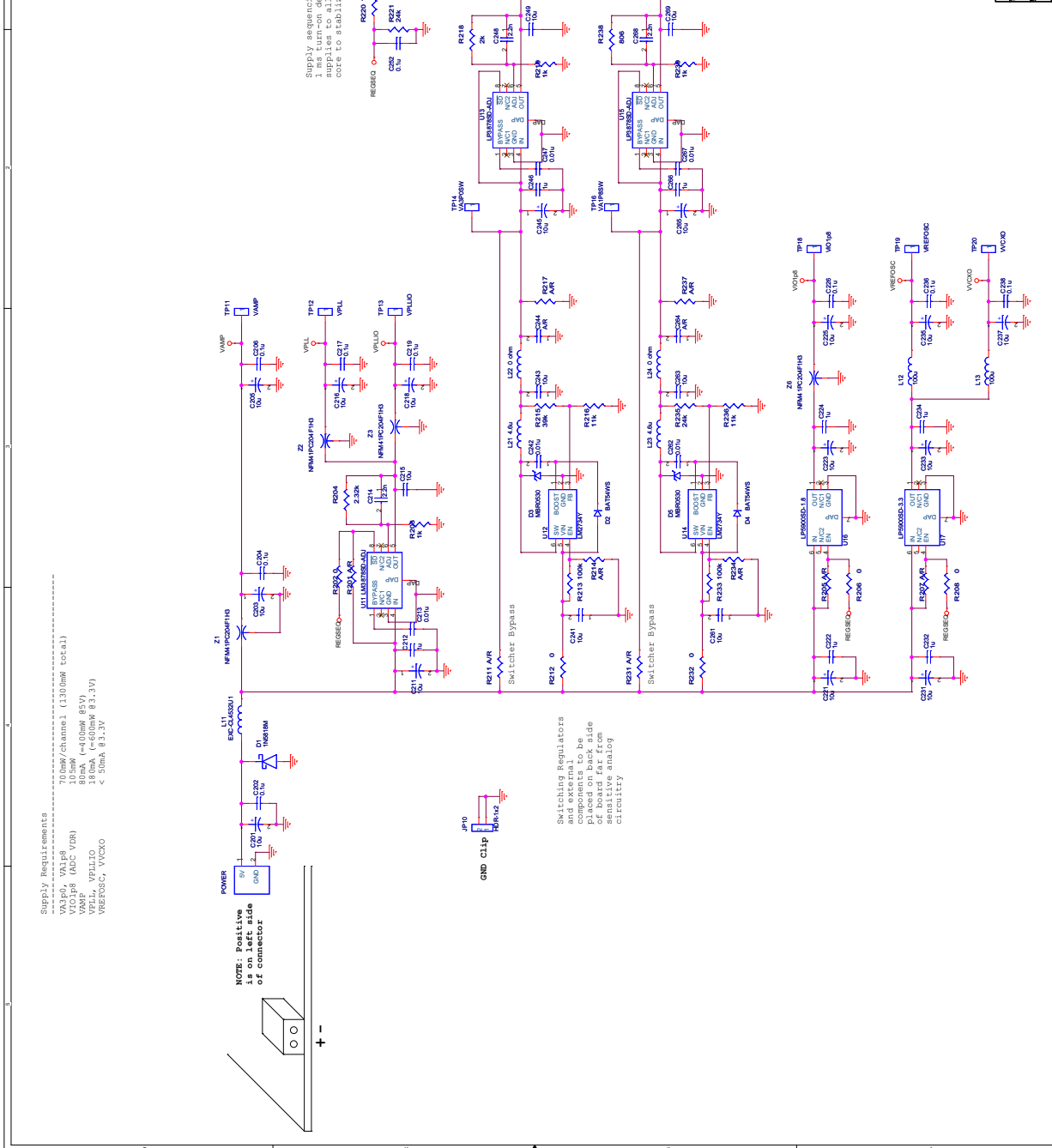

Figure 26: Power Distribution

11.0 Layout

NATIONAL SEMICONDUCTOR LAYER1 SILK

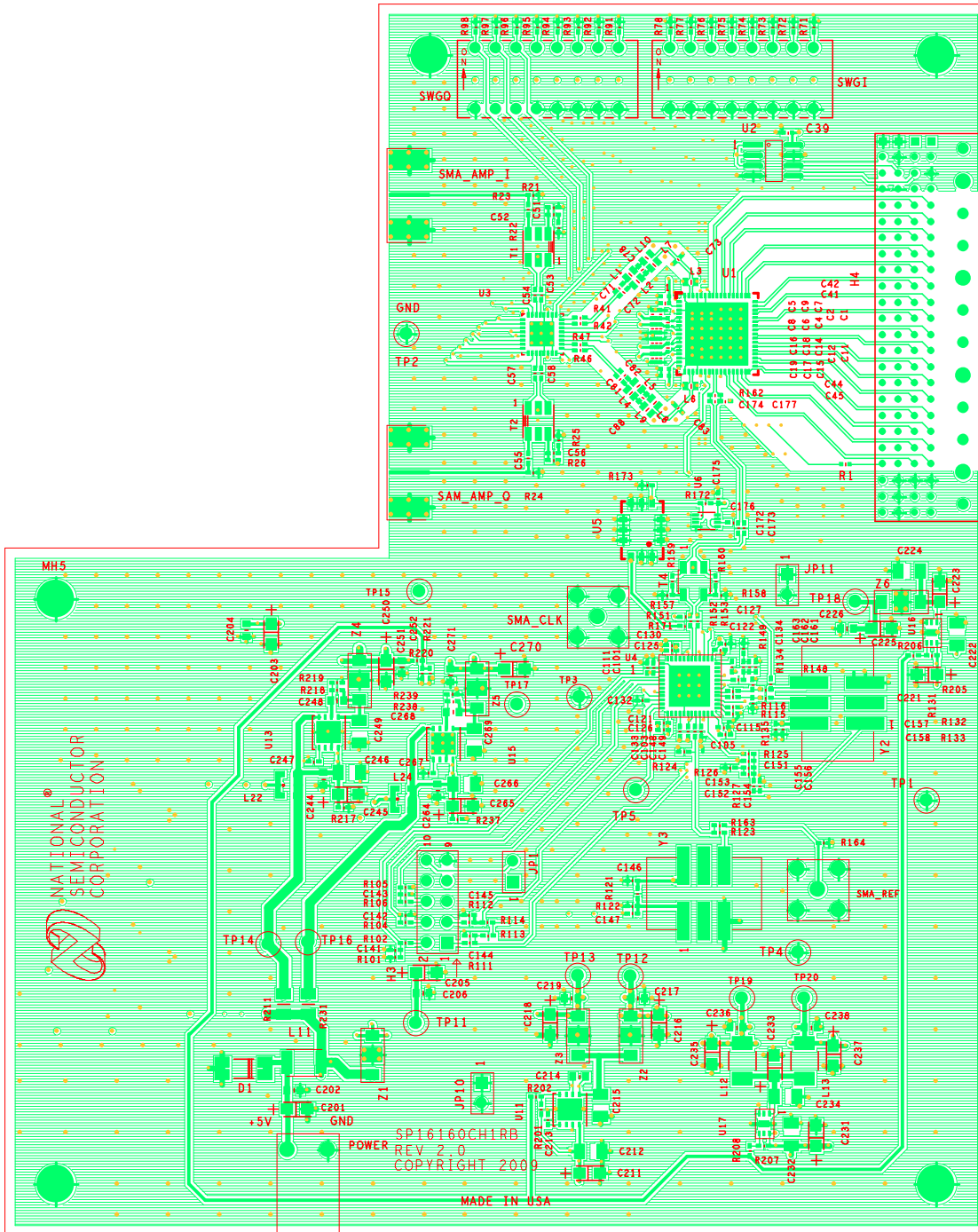

Figure 27: Layer 1 - Signal

NATIONAL SEMICONDUCTOR LAYER2

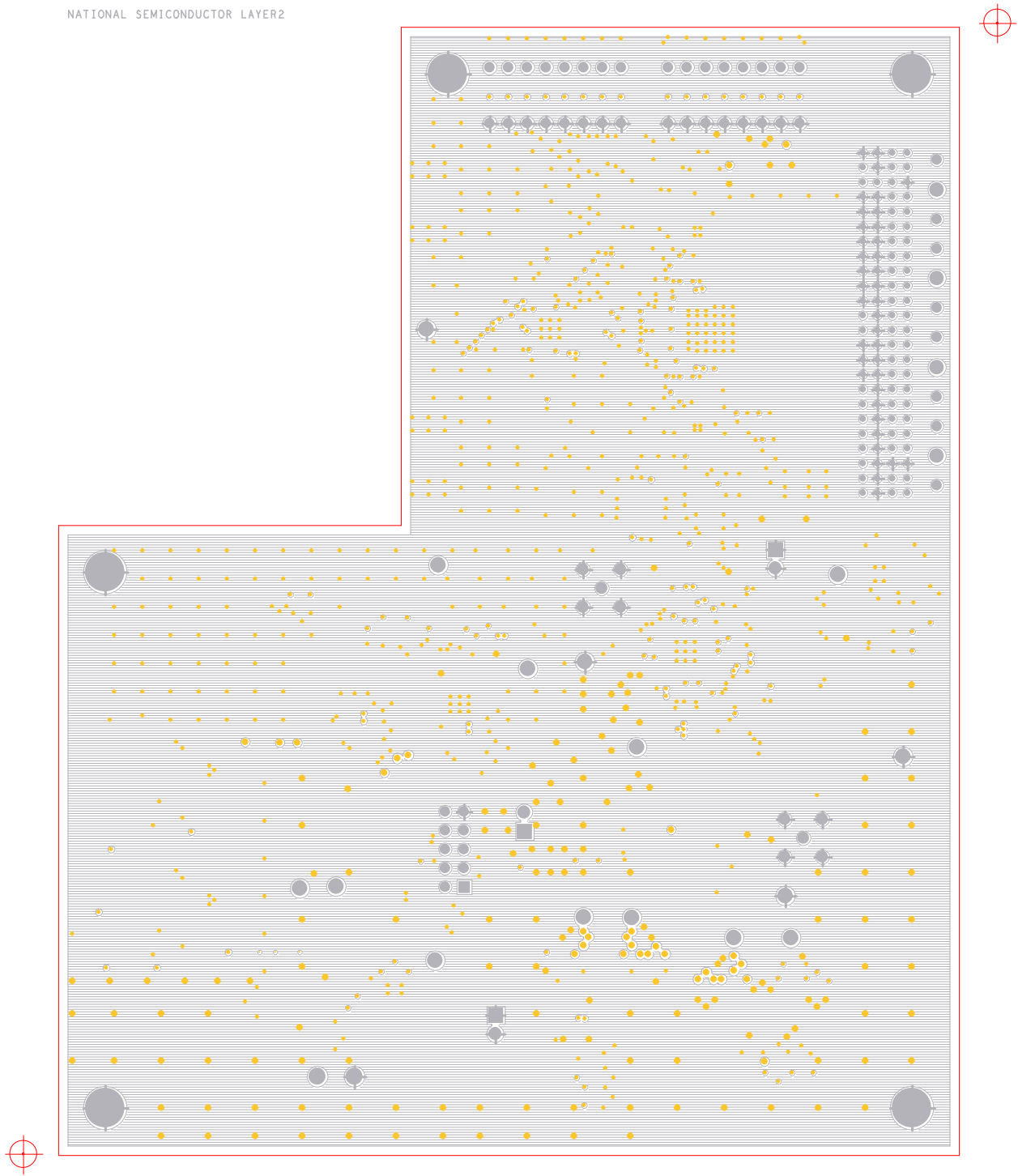

Figure 28: Layer 2 - Ground

NATIONAL SEMICONDUCTOR LAYER3

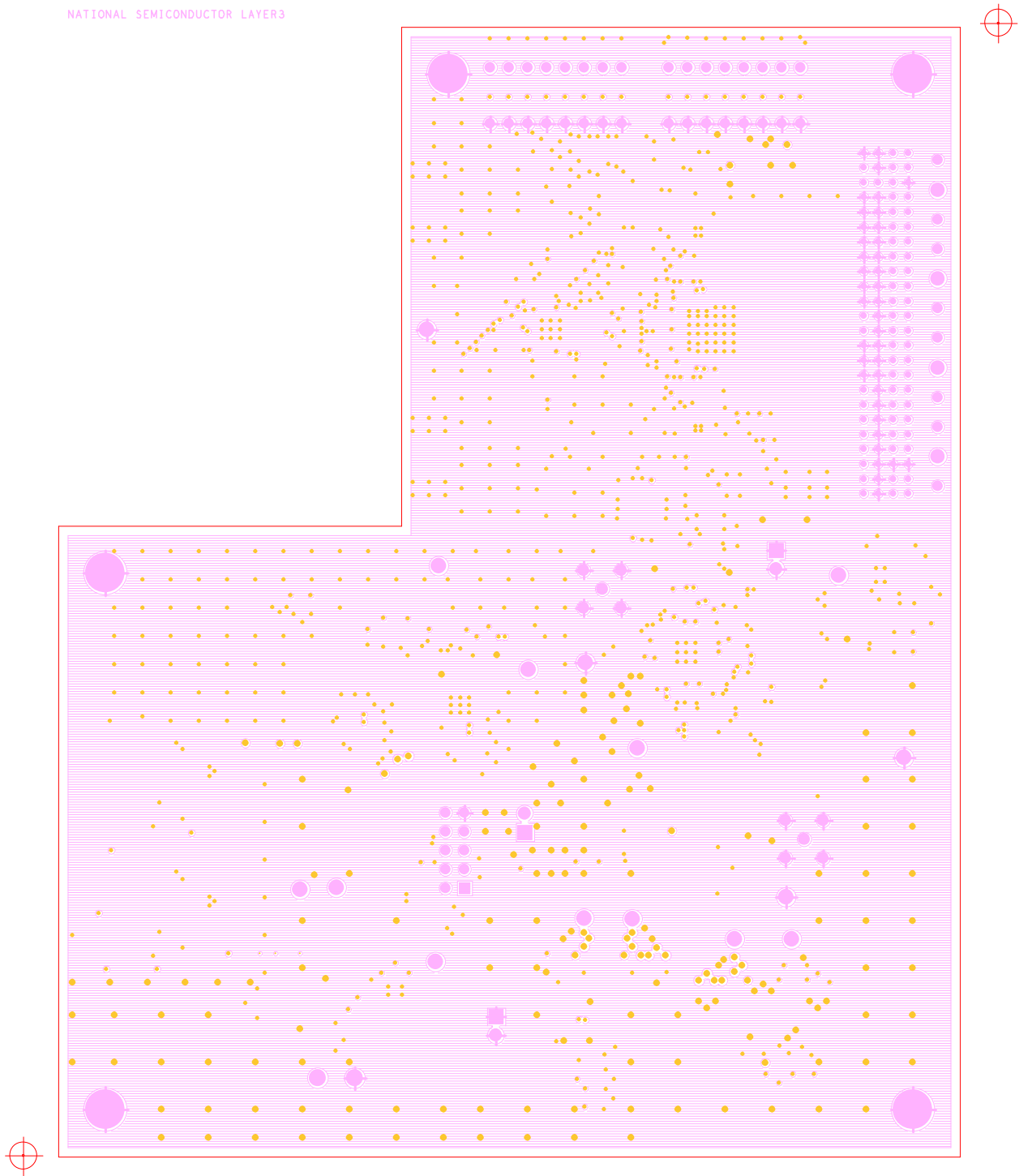

Figure 29: Layer 3 - Ground

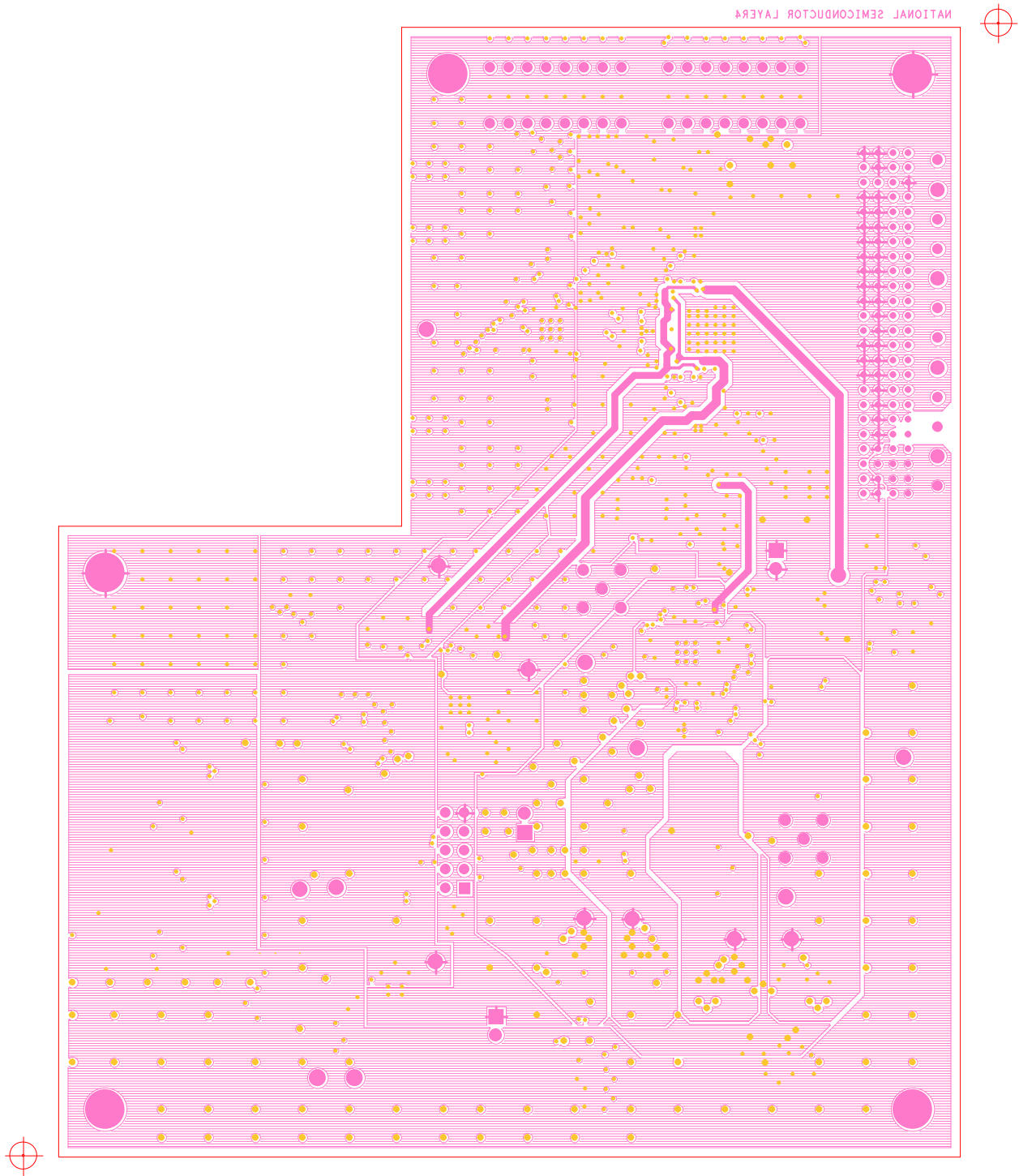

Figure 30: Layer 4 - Power

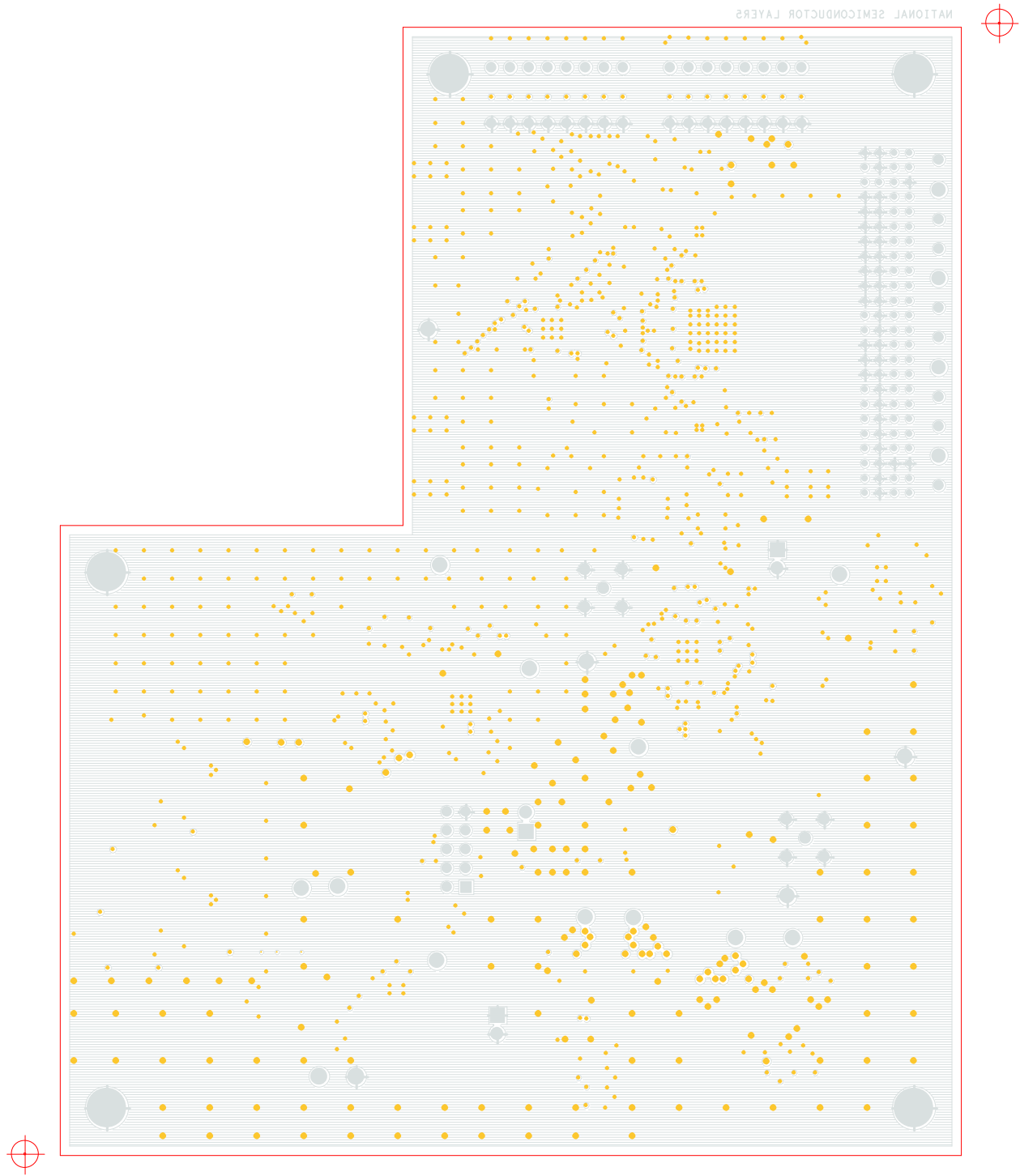

Figure 31: Layer 5 - Ground

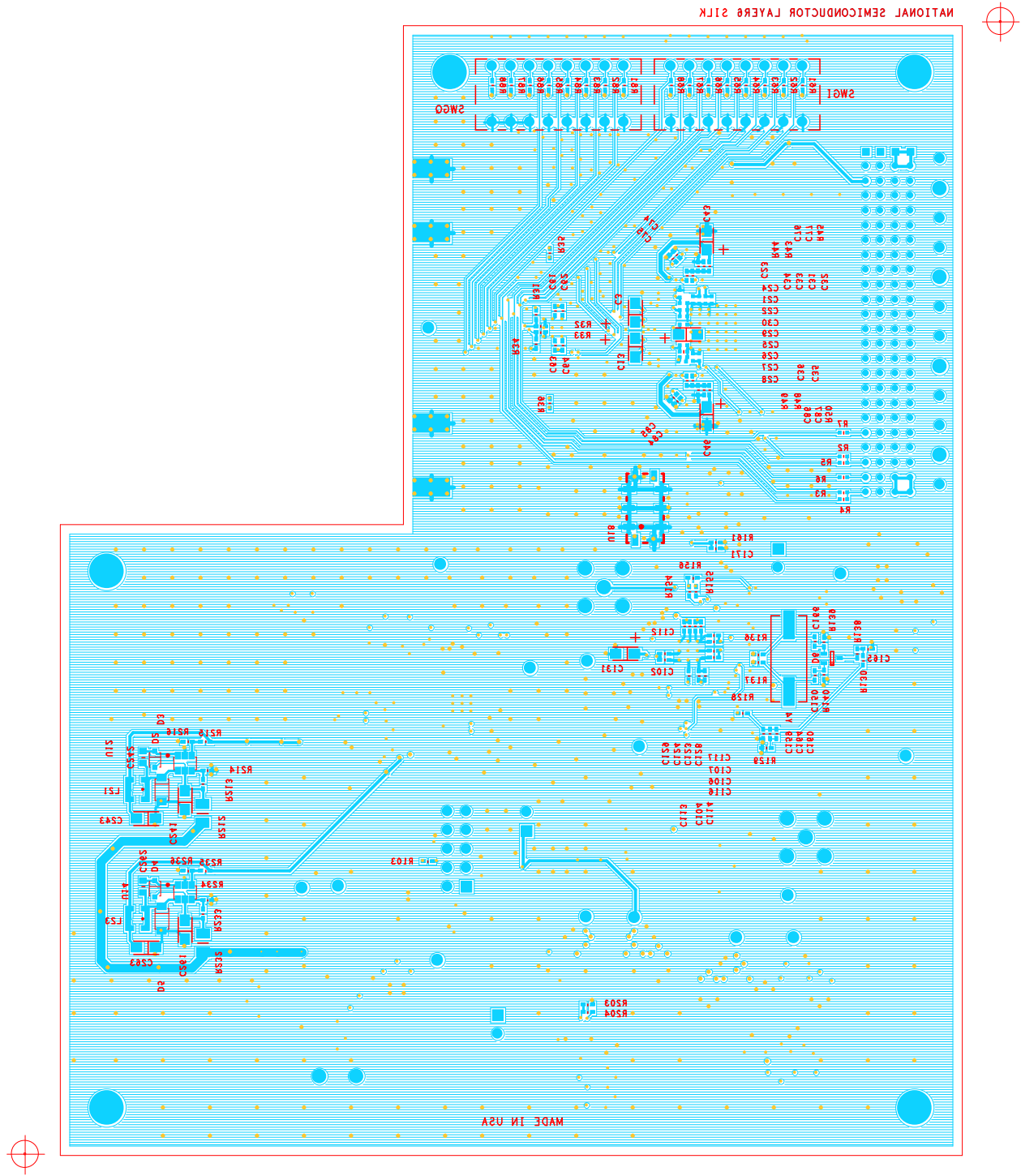

Figure 32: Layer 6 - Signal

SP16160CH1RB Reference Design Board User's Guide

The SP16160CH1RB Reference Design Board is intended for product evaluation purposes only and is not intended for resale to end consumers, is not authorized for such use and is not designed for compliance with European EMC Directive 89/336/EEC.

National does not assume any responsibility for any circuitry described. No circuit patent licenses are implied and National reserves the right at any time without notice to change said circuitry and specifications.

WaveVision is a trademark of National Semiconductor Corporation

LIFE SUPPORT POLICY

NATIONAL'S PRODUCTS ARE NOT AUTHORIZED FOR USE AS CRITICAL COMPONENTS IN LIFE SUPPORT DEVICES OR SYSTEMS WITHOUT THE EXPRESS WRITTEN APPROVAL OF THE PRESIDENT OF NATIONAL SEMICONDUCTOR CORPORATION. As used herein:

1. Life support devices or systems are devices or systems which, (a) are intended for surgical implant into the body, or (b) support or sustain life, and whose failure to perform, when properly used in accordance with instructions for use provided in the labeling, can be reasonably expected to result in a significant injury to the user.
2. A critical component is any component in a life support device or system whose failure to perform can be reasonably expected to cause the failure of the life support device or system, or to affect its safety or effectiveness.

National Semiconductor Corporation Americas	National Semiconductor Europe	National Semiconductor Asia Pacific Customer Response Group	National Semiconductor Japan Ltd.
Tel: 1-800-272-9959	Fax: +49 (0) 1 80-530 85 86	Tel: 65-2544466	Tel: 81-3-5639-7560
Fax: 1-800-737-7018	Email: europe.support@nsc.com	Fax: 65-2504466	Fax: 81-3-5639-7507
Email: support@nsc.com	Deutsch Tel: +49 (0) 1 80-530 85 85	Email: sea.support@nsc.com	
	English Tel: +49 (0) 1 80 532 78 32		

IMPORTANT NOTICE

Texas Instruments Incorporated and its subsidiaries (TI) reserve the right to make corrections, modifications, enhancements, improvements, and other changes to its products and services at any time and to discontinue any product or service without notice. Customers should obtain the latest relevant information before placing orders and should verify that such information is current and complete. All products are sold subject to TI's terms and conditions of sale supplied at the time of order acknowledgment.

TI warrants performance of its hardware products to the specifications applicable at the time of sale in accordance with TI's standard warranty. Testing and other quality control techniques are used to the extent TI deems necessary to support this warranty. Except where mandated by government requirements, testing of all parameters of each product is not necessarily performed.

TI assumes no liability for applications assistance or customer product design. Customers are responsible for their products and applications using TI components. To minimize the risks associated with customer products and applications, customers should provide adequate design and operating safeguards.

TI does not warrant or represent that any license, either express or implied, is granted under any TI patent right, copyright, mask work right, or other TI intellectual property right relating to any combination, machine, or process in which TI products or services are used. Information published by TI regarding third-party products or services does not constitute a license from TI to use such products or services or a warranty or endorsement thereof. Use of such information may require a license from a third party under the patents or other intellectual property of the third party, or a license from TI under the patents or other intellectual property of TI.

Reproduction of TI information in TI data books or data sheets is permissible only if reproduction is without alteration and is accompanied by all associated warranties, conditions, limitations, and notices. Reproduction of this information with alteration is an unfair and deceptive business practice. TI is not responsible or liable for such altered documentation. Information of third parties may be subject to additional restrictions.

Resale of TI products or services with statements different from or beyond the parameters stated by TI for that product or service voids all express and any implied warranties for the associated TI product or service and is an unfair and deceptive business practice. TI is not responsible or liable for any such statements.

TI products are not authorized for use in safety-critical applications (such as life support) where a failure of the TI product would reasonably be expected to cause severe personal injury or death, unless officers of the parties have executed an agreement specifically governing such use. Buyers represent that they have all necessary expertise in the safety and regulatory ramifications of their applications, and acknowledge and agree that they are solely responsible for all legal, regulatory and safety-related requirements concerning their products and any use of TI products in such safety-critical applications, notwithstanding any applications-related information or support that may be provided by TI. Further, Buyers must fully indemnify TI and its representatives against any damages arising out of the use of TI products in such safety-critical applications.

TI products are neither designed nor intended for use in military/aerospace applications or environments unless the TI products are specifically designated by TI as military-grade or "enhanced plastic." Only products designated by TI as military-grade meet military specifications. Buyers acknowledge and agree that any such use of TI products which TI has not designated as military-grade is solely at the Buyer's risk, and that they are solely responsible for compliance with all legal and regulatory requirements in connection with such use.

TI products are neither designed nor intended for use in automotive applications or environments unless the specific TI products are designated by TI as compliant with ISO/TS 16949 requirements. Buyers acknowledge and agree that, if they use any non-designated products in automotive applications, TI will not be responsible for any failure to meet such requirements.

Following are URLs where you can obtain information on other Texas Instruments products and application solutions:

Products

Audio	www.ti.com/audio
Amplifiers	amplifier.ti.com
Data Converters	dataconverter.ti.com
DLP® Products	www.dlp.com
DSP	dsp.ti.com
Clocks and Timers	www.ti.com/clocks
Interface	interface.ti.com
Logic	logic.ti.com
Power Mgmt	power.ti.com
Microcontrollers	microcontroller.ti.com
RFID	www.ti-rfid.com
OMAP Mobile Processors	www.ti.com/omap
Wireless Connectivity	www.ti.com/wirelessconnectivity

Applications

Automotive and Transportation	www.ti.com/automotive
Communications and Telecom	www.ti.com/communications
Computers and Peripherals	www.ti.com/computers
Consumer Electronics	www.ti.com/consumer-apps
Energy and Lighting	www.ti.com/energy
Industrial	www.ti.com/industrial
Medical	www.ti.com/medical
Security	www.ti.com/security
Space, Avionics and Defense	www.ti.com/space-avionics-defense
Video and Imaging	www.ti.com/video



TI E2E Community Home Page

e2e.ti.com

Mailing Address: Texas Instruments, Post Office Box 655303, Dallas, Texas 75265
Copyright © 2012, Texas Instruments Incorporated

Looking for pricing, stock, or lifecycle information?

Click below to explore more details on WIN SOURCE:

-  [View SP16160CH1RBKIT/NOPB on WIN SOURCE](#)
-  [Texas Instruments](#) Information

Optimize Your Supply Chain with WIN SOURCE Solutions

-  Global Sourcing Solution
-  Obsolete Management
-  Cost Control Management
-  Shortage Management
-  Alternative Solution
-  Excess Inventory Management