



THE DATASHEET OF S12ZVMAEVB



S12ZVMAEVB QUICK START GUIDE (QSG)

ULTRA-RELIABLE MICROCONTROLLERS
FOR INDUSTRIAL AND AUTOMOTIVE

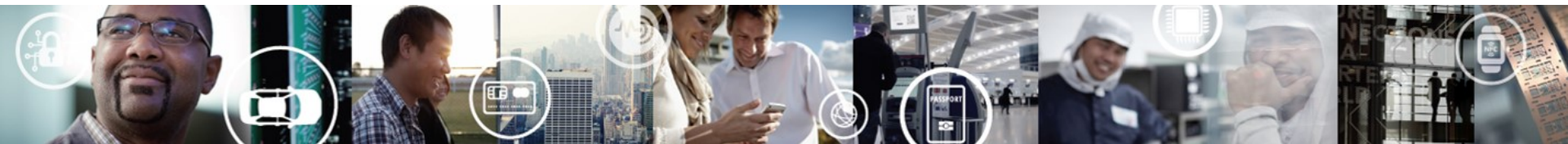

Get to know the S12ZVMAEVB

The S12ZVMA is a programmable single-chip solution for simple loads needed to be controlled in the car remotely via LIN or PWM command.

Integrated LIN-PHY, 12V-Vreg, and half-bridge gate driver allow building extremely compact solutions for DC-motors, solenoids or resistive loads

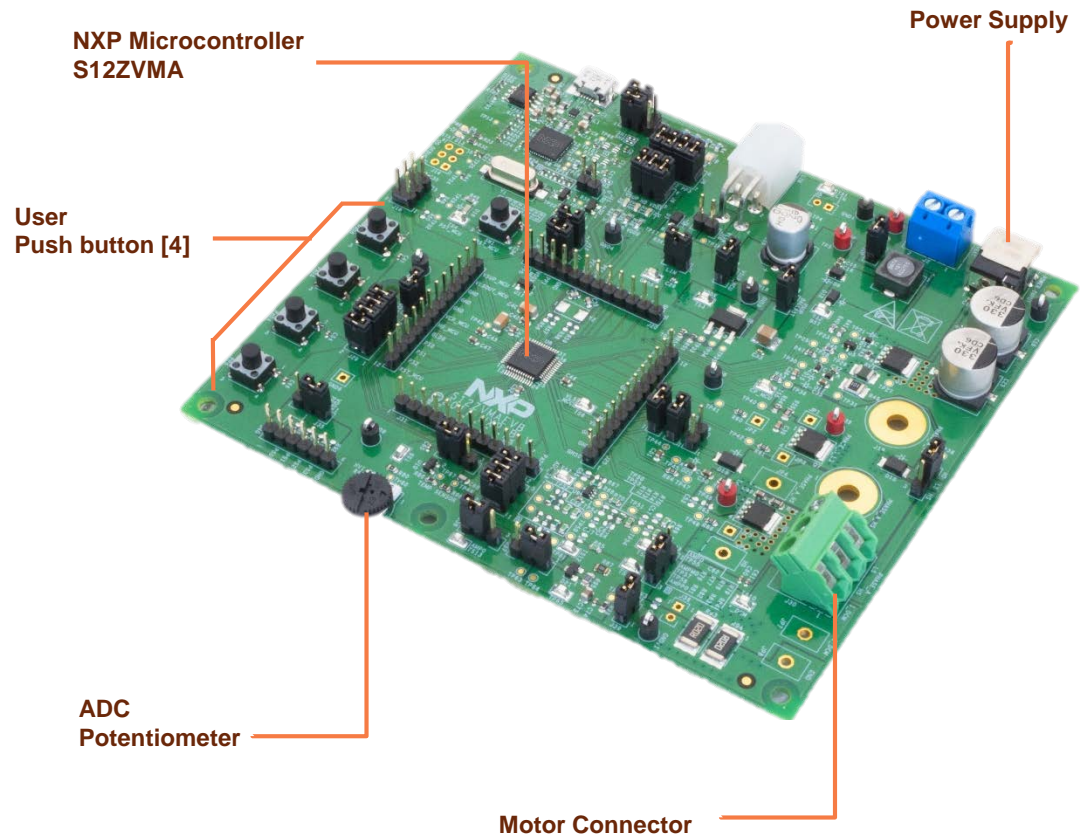

Step-by-Step Installation Instructions

In this quick start guide, you will learn how to set up the **S12ZVMAEVB** board and run the default exercise.

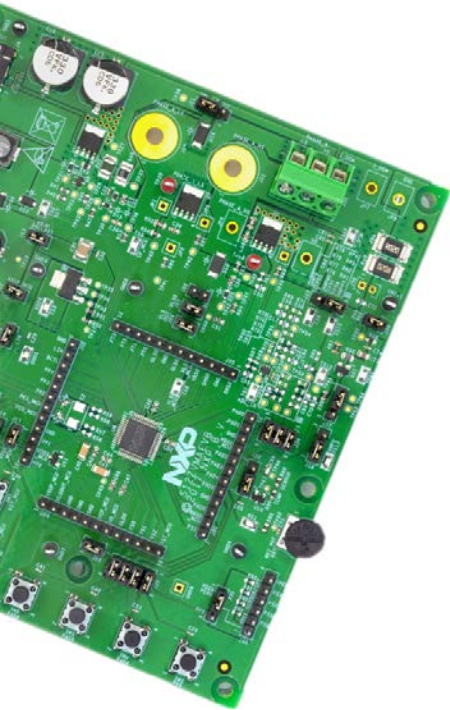

1

Install Software and Tools

Install [CodeWarrior Development Studio v11](#) for S12Z devices. CodeWarrior Dev Tools for MagniV MCUs

2

Connect the USB Cable

Connect one end of the USB cable to the PC and the other end to the mini-B connector on the S12ZVMAEVB board. Allow the PC to automatically configure the USB drivers if needed.

3

Using the Example Project

Load the example code contained in your quick start package to enable the push buttons and the potentiometer..

4

Learn More About the S12ZVMA

Read the release notes and documentation on the nxp.com/S12ZVMA.

- The Processor Expert graphical initialization software included in your CodeWarrior installation will help reduce your time to market

Peripheral List

The table below shows the components available in the EVB as well as the pin number where it's connected.

Peripheral	ID	MCU PORT	Description
Potentiometer	R97	PAD3	Potentiometer connected to ADC channel 3
Temperature sensor	KTY82	PAD3	Potentiometer connected to ADC channel 3
LED – Voltage indicator	D9	-	VSUP LED Indicator
	D10	-	HD LED Indicator
	D11	-	VDDX LED Indicator
LED – User Interface	D1	PP0	User LED 1
	D2	PP1	User LED 2
	D3	PP2	User LED 3
	D4	PP3	User LED 4
Switch Panel	SW2	PAD6	User switches
	SW3	PAD5	
	SW4	PAD4	
	SW5	PP4	
Reset	SW1	-	Reset Switch

Default Jumper configuration

J7	Vsup Enable	
	Closing This jumper connects Vbat to the rest of the board	
J9	Power Supply Voltages – LEEDs indicators	
	Pin 1-2 Closed	Enable Vsup LED indicator
	Pin 3-4 Closed	Enable HD LED indicator
	Pin 5-6 Closed	Enable VDDX LED indicator
J15	Master mode enabled	
	Connects pullup resistors in order for the board to function as LIN master	
J10	Power supply via LIN	
	Closing this jumper connects Vbat to pin 3 of LIN Connector	
J26	VLS OUT enabled	
	Closing this jumper connects VLS_OUT pin to the rest of the board	

Default Jumper configuration

J17	VDDX enabled
	Closing this jumper connects VDDX to the MCU
J16	VDDX_PERH
	Closing this jumper connects VDDX as supplying source for the peripherals
J13	Voltage supply for the ballast transistor enable
	Closing this jumper connects Vsup to the ballast transistor
J12	Voltage supply for the MCU enable
	Closing this jumper connects Vsup to the MCU
J23	Reverse Battery and charge pump enabled
	Closing this jumper connects HD signal to the HD_pin of the MCU
J28	High-Side recirculation diode enable
	Closing this jumper enables D19 to function as a recirculation diode when the motor is been drove by the high-side.

Default Jumper configuration

J21	Pin 1-2 Closed	Diode is connected to HD
	Pin 2-3 Closed	Diode is connected to HS
J33	Current measurement selector	
	Pin 1-2 Closed	External operational amplifier is selected for measure the current
	Pin 2-3 Closed	Internal operational amplifier is selected for measure the current
J37	Internal operational amplifier reference voltage selector	
	Pin 1-2 Closed	2.5 V reference selected
	Pin 2-3 Closed	5 V reference selected
J38	Internal operational amplifier reference voltage selector	
	Pin 1-2 Closed	2.5 V reference selected
	Pin 2-3 Closed	5 V reference selected

Default Jumper configuration

J38	Pin 1-2 Closed	Internal output comparator routed to PAD2
	Pin 2-3 Closed	External output comparator routed to PAD2
J34	Internal operational amplifier routing	
	Pin 1-2 Closed	Enables 5 V reference to internal operational amplifier
	Pin 3-4 Closed	AMPP0 routed to PAD0
	Pin 5-6 Closed	AMPM0 routed to PAD1
J39	2.5 Voltage Enable	
	Closing this jumper enables the 2.5 V reference for the operational amplifiers.	

Default Jumper configuration

J22	Switches	
	Pin 1-2 Closed	SW5 routed to PP4
	Pin 3-4 Closed	SW4 routed to PAD4
	Pin 5-6 Closed	SW3 routed to PAD5
	Pin 7-8 Closed	SW2 routed to PAD6
J22	LEDs	
	Pin 1-2 Closed	D1 routed to PP0
	Pin 3-4 Closed	D2 routed to PP1
	Pin 5-6 Closed	D3 routed to PP2
	Pin 7-8 Closed	D4 routed to PP3

Default Jumper configuration

J35	Hall Sensor voltage supply	
	Pin 1-2 Closed	Voltage is supplied to Hall sensor using VDDX
	Pin 2-3 Closed	Voltage is supplied to Hall sensor using EVDD pin (PP0)
J32	Potenciometer / Temperature Sensor selector	
	Pin 1-2 Closed	Potenciometer is routed to PAD3
	Pin 2-3 Closed	Temperature sensor is routed to PAD3
J11	Bootloader Enable	
	Closing this jumper enables the OSBDM to start in bootloader mode.	
J22	OSBDM Rx/Tx routing	
	Pin 1-3 Closed	OSBDM Rx routed to PP1
	Pin 3-5 Closed	OSBDM Rx routed to PE0
	Pin 2-4 Closed	OSBDM Tx routed to PP0
	Pin 7-8 Closed	OSBDM Tx routed to PE1

Default Jumper configuration

J21	HVI Circuit –Reference Voltage Selector	
	Pin 1-2 Closed	- SW1 is connected to VBAT level. This provides a HIGH voltage level when switch SW1 is pressed.
	Pin 4-6 Closed	- SW1 is connected to GND level. This provides a LOW voltage level when switch SW1 is pressed.

Internal Operational Amplifier

- The internal amplifier signals of the S12ZVMA EVB are not correctly routed. In order to use the internal amplifier of the S12ZVMA some jumpers need to be open and some external cables connected in order to get the amplifier to work:
- Open jumpers: J32, J34 (3-4, 5-6), J38.
- External cables: Connected from J38 pin 1 to PAD3 of the header ring, J34 pin 3 to PAD1 of the header ring, J34 pin 5 to PAD2 of the header ring.
- The following images show the changes explained above:

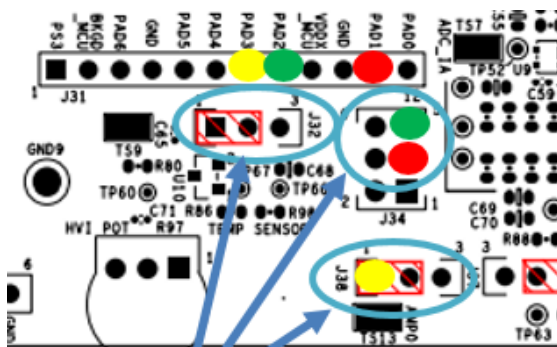



SECURE CONNECTIONS
FOR A SMARTER WORLD

Looking for pricing, stock, or lifecycle information?

Click below to explore more details on WIN SOURCE:

 [View S12ZVMAEVB on WIN SOURCE](#)

 [NXP / Nexperia Information](#)

Optimize Your Supply Chain with WIN SOURCE Solutions

-  Global Sourcing Solution
-  Obsolete Management
-  Cost Control Management
-  Shortage Management
-  Alternative Solution
-  Excess Inventory Management