



THE DATASHEET OF SCA3060-D01 DEMO



Data Sheet



SCA3060-D01 DIGITAL LOW POWER ACCELEROMETER FOR NON-SAFETY CRITICAL AUTOMOTIVE APPLICATIONS

Features

- 3,0 V – 3,6 V supply voltage
- ± 2 g measurement range
- 16 bit SPI digital interface
- Selectable frequency response
- Very low current consumption (3.3 V, 150 μ A typ)
- 64 samples/axis buffer memory for output acceleration data and advanced features enable significant power and resource savings at system level
- Interrupt signal triggered by motion
- Size 7.6 x 3.3 x 8.6 mm (w x h x l)
- Proven capacitive 3D-MEMS technology
- High shock durability
- RoHS compliant / lead free soldering
- AEC Q-100 qualified

Applications

SCA3060-D01 is targeted to non-safety critical automotive applications such as

- Inertial navigation
- Vehicle alarms
- Inclination sensing
- Motion activation
- Black box systems

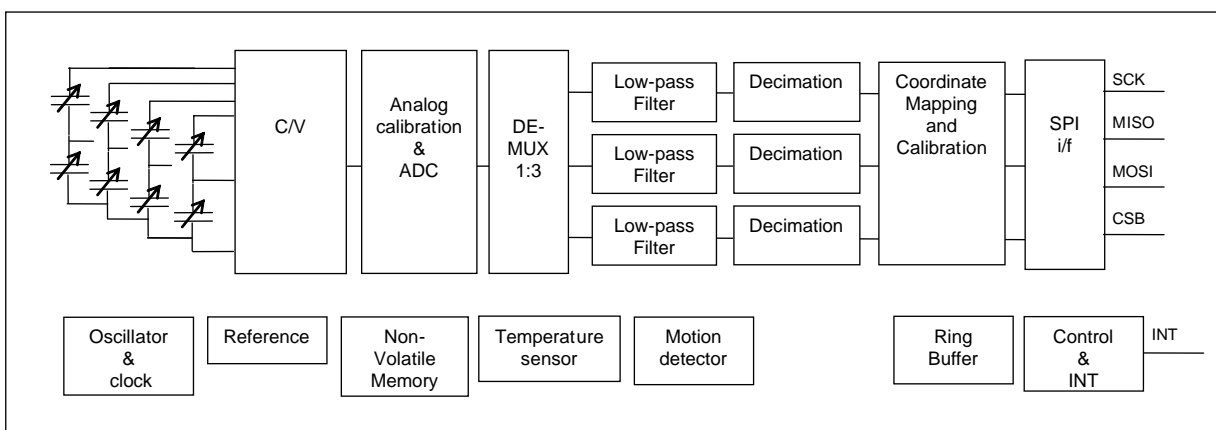

Figure 1 SCA3060-D01 Block Diagram

Performance Characteristics ¹⁾

Parameter	Condition				Units
		Min	Typ ¹⁾	Max	
Analog and digital Vdd		3.0	3.3	3.6	V
Operating temperature **		-40	-	105	°C
Current consumption *	Reset ²⁾	-	<9	-	µA
	Measurement / MD mode	-	150	-	µA
Acceleration range * ³⁾	Nominal	-	± 2	-	g
Total offset error ⁴⁾	-40 ... +105 °C	-200	±200	+200	mg
Sensitivity * ⁶⁾		-	1000	-	Count/g
Total Sensitivity error *		-	±2%	±4%	%
Non-Linearity ** ⁷⁾		-	±1	±3%	% FS
Cross-Axis sensitivity ** ⁸⁾		-	±3	-	%
Bandwidth ** ⁹⁾	Measurement mode		9		Hz
	Wide band mode		35		Hz
Noise ** ¹⁰⁾	Measurement mode		9		mg RMS
	Wide band mode	-	16	-	mg RMS
Output data rate **	Measurement mode		50		Hz
	Wide band mode		100		Hz
Start up time ** ¹¹⁾		-	200	-	ms
Output load **		-	-	35	pF
SPI clock rate **		-	-	325	kHz

* 100% tested in production

** Qualified during product validation

1) Typical values are not guaranteed.

2) Includes the current through the internal 400 kΩ pull-up resistor connected to digital I/O Vdd.

3) Range defined as $\sqrt{x^2+y^2+z^2} \leq 2g$. The measuring range is tested on sensing element level. FS = 2g.

4) Includes effects over supply voltage, temperature and life time

6) Sensitivity = {Count(+1g) - Count(-1g)}/2 [Count/g].

7) From straight line through sensitivity calibration (+1g, -1g) points.

8) The cross-axis sensitivity determines how much acceleration, perpendicular to the measuring axis, couples to the output. The total cross-axis sensitivity is the geometric sum of the sensitivities of the two axes which are perpendicular to the measuring axis. The angular alignment error between X, Y and Z axis is included into the cross axis sensitivity.

9) Frequency responses according to Figure 4.

10) Average noise/axis over the measurement bandwidth defined as $\sqrt{\frac{1}{3}(n_x^2+n_y^2+n_z^2)}$, where n_x , n_y and n_z are

the measured signal's standard deviation due to noise in x, y and z directions.

11) Settling error less than 1% of FS.

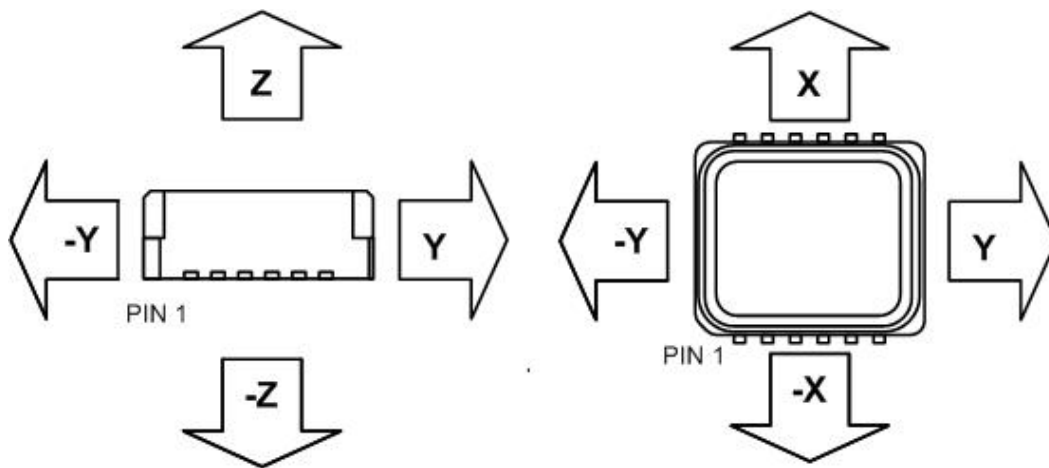

Figure 2 Accelerometer measuring directions

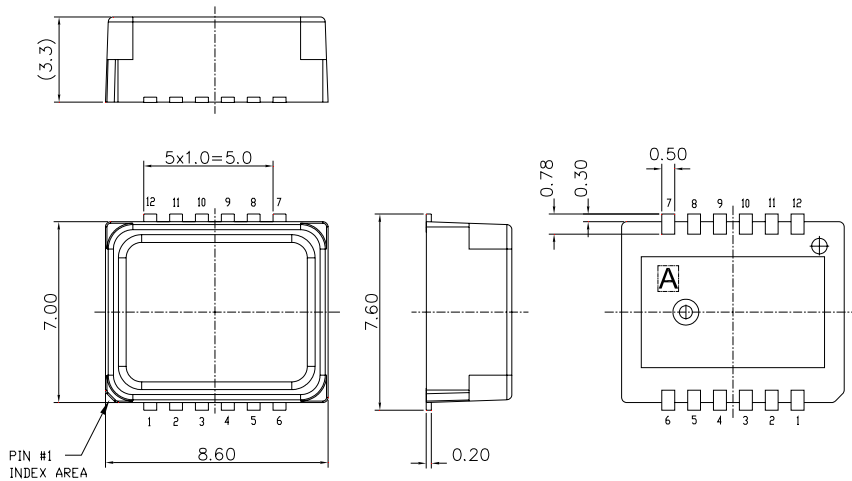

figure 3 housing dimensions

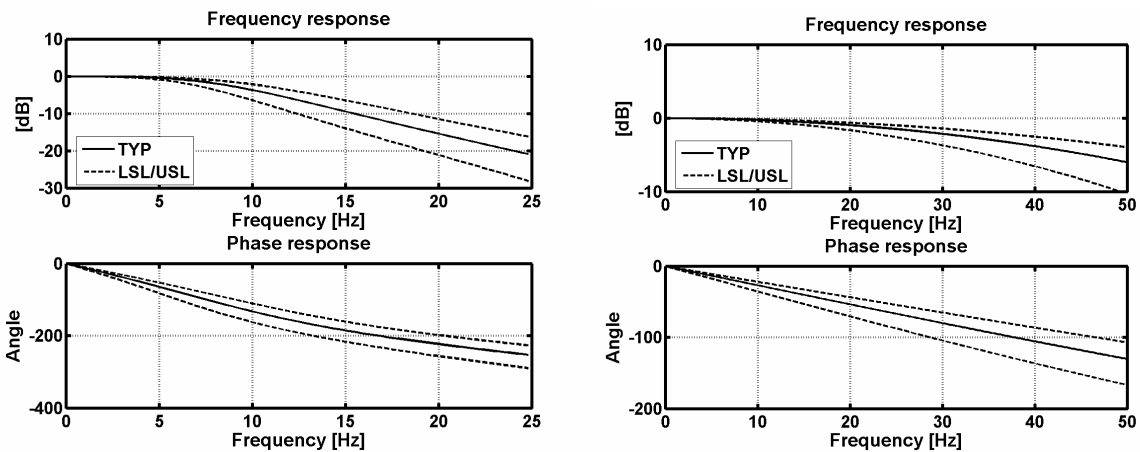

Figure 4 Frequency response of SCA3060-D01 in measurement mode (left) and in wide band mode (right)

Looking for pricing, stock, or lifecycle information?

Click below to explore more details on WIN SOURCE:

- ⊖ [View SCA3060-D01DEMO on WIN SOURCE](#)
- ⊖ [Murata Electronics North America Information](#)

Optimize Your Supply Chain with WIN SOURCE Solutions

- ✓ Global Sourcing Solution
- ✓ Obsolete Management
- ✓ Cost Control Management
- ✓ Shortage Management
- ✓ Alternative Solution
- ✓ Excess Inventory Management