



# THE DATASHEET OF STEVAL-MKI154V1



## LSM9DS0 9-axis iNEMO combo module adapter board for standard DIL 24 socket, compatible with STEVAL-MKI109V2

Data brief

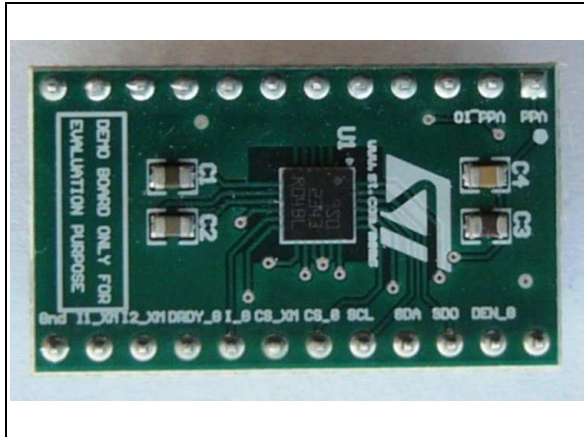

### Features

- Complete LSM9DS0 pinout for a standard DIL 24 socket
- Fully compatible with STEVAL-MKI109V2 motherboard
- RoHS compliant

### Description

The STEVAL-MKI154V1 is an adapter board designed to facilitate the evaluation of MEMS devices in the LSM9DS0 product family. The board offers an effective solution for fast system prototyping and device evaluation directly within the user's own application.

The STEVAL-MKI154V1 can be plugged into a standard DIL 24 socket. The adapter provides the complete LSM9DS0 pinout and comes ready-to-use with the required decoupling capacitors on the VDD power supply line.

This adapter is supported by STEVAL-MKI109V2, which is a motherboard including a high-performance 32-bit microcontroller which functions as a bridge between the sensor and a PC, on which it is possible to use the downloadable graphical user interface (Unico GUI), or dedicated software routines for customized applications.

# 1 Schematic diagram

Figure 1. STEVAL-MKI154V1 circuit schematic

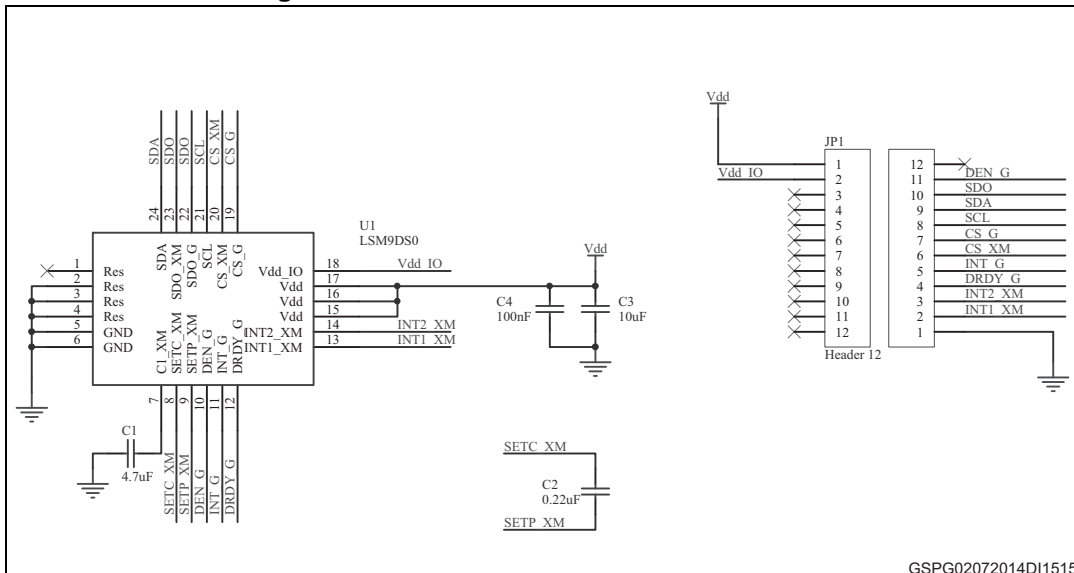

GSPG02072014D11515

## 2 Revision history

Table 1. Document revision history

Date	Revision	Changes
07-Jul-2014	1	Initial release.
19-Sep-2014	2	Modified title in cover page.

**IMPORTANT NOTICE – PLEASE READ CAREFULLY**

STMicroelectronics NV and its subsidiaries ("ST") reserve the right to make changes, corrections, enhancements, modifications, and improvements to ST products and/or to this document at any time without notice. Purchasers should obtain the latest relevant information on ST products before placing orders. ST products are sold pursuant to ST's terms and conditions of sale in place at the time of order acknowledgement.

Purchasers are solely responsible for the choice, selection, and use of ST products and ST assumes no liability for application assistance or the design of Purchasers' products.

No license, express or implied, to any intellectual property right is granted by ST herein.

Resale of ST products with provisions different from the information set forth herein shall void any warranty granted by ST for such product.



ST and the ST logo are trademarks of ST. All other product or service names are the property of their respective owners.

Information in this document supersedes and replaces information previously supplied in any prior versions of this document.

© 2014 STMicroelectronics – All rights reserved

## Looking for pricing, stock, or lifecycle information?

Click below to explore more details on WIN SOURCE:

-  [View STEVAL-MKI154V1 on WIN SOURCE](#)
-  [STMicroelectronics](#) Information

## Optimize Your Supply Chain with WIN SOURCE Solutions

-  Global Sourcing Solution
-  Obsolete Management
-  Cost Control Management
-  Shortage Management
-  Alternative Solution
-  Excess Inventory Management