



**THE DATASHEET OF
SK-AX2-CG624-KITBTM**



SN54ABT162841, SN74ABT162841 20-BIT BUS-INTERFACE D-TYPE LATCHES WITH 3-STATE OUTPUTS

SCBS665C – JUNE 1996 – REVISED JUNE 2004

- Members of the Texas Instruments Widebus™ Family
- Output Ports Have Equivalent 25-Ω Series Resistors, So No External Resistors Are Required
- Typical V_{OLP} (Output Ground Bounce) <0.8 V at $V_{CC} = 5$ V, $T_A = 25^\circ\text{C}$
- High-Impedance State During Power Up and Power Down
- I_{off} and Power-Up 3-State Support Hot Insertion
- Distributed V_{CC} and GND Pins Minimize High-Speed Switching Noise
- Flow-Through Architecture Optimizes PCB Layout
- Latch-Up Performance Exceeds 500 mA Per JEDEC Standard JESD-17

SN54ABT162841 . . . WD PACKAGE
SN74ABT162841 . . . DGG OR DL PACKAGE
(TOP VIEW)

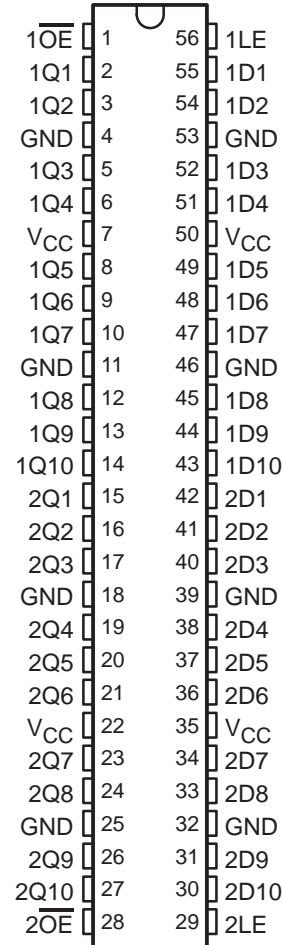

description/ordering information

These 20-bit transparent D-type latches feature noninverting 3-state outputs designed specifically for driving highly capacitive or relatively low-impedance loads. They are particularly suitable for implementing buffer registers, I/O ports, bidirectional bus drivers, and working registers.

The 'ABT162841 devices can be used as two 10-bit latches or one 20-bit latch. While the latch-enable (1LE or 2LE) input is high, the Q outputs of the corresponding 10-bit latch follow the data (D) inputs. When LE is taken low, the Q outputs are latched at the levels set up at the D inputs.

ORDERING INFORMATION

T_A	PACKAGE†		ORDERABLE PART NUMBER	TOP-SIDE MARKING
-40°C to 85°C	SSOP – DL	Tube	SN74ABT162841DL	ABT162841
		Tape and reel	SN74ABT162841DLR	
	TSSOP – DGG	Tape and reel	SN74ABT162841DGGR	ABT162841
-55°C to 125°C	CFP – WD	Tube	SNJ54ABT162841WD	SNJ54ABT162841WD

† Package drawings, standard packing quantities, thermal data, symbolization, and PCB design guidelines are available at www.ti.com/sc/package.



Please be aware that an important notice concerning availability, standard warranty, and use in critical applications of Texas Instruments semiconductor products and disclaimers thereto appears at the end of this data sheet.

Widebus is a trademark of Texas Instruments.

UNLESS OTHERWISE NOTED this document contains PRODUCTION DATA information current as of publication date. Products conform to specifications per the terms of Texas Instruments standard warranty. Production processing does not necessarily include testing of all parameters.



POST OFFICE BOX 655303 • DALLAS, TEXAS 75265

Copyright © 2004, Texas Instruments Incorporated

SN54ABT162841, SN74ABT162841 20-BIT BUS-INTERFACE D-TYPE LATCHES WITH 3-STATE OUTPUTS

SCBS665C – JUNE 1996 – REVISED JUNE 2004

description/ordering information (continued)

A buffered output-enable ($\overline{1OE}$ or $\overline{2OE}$) input can be used to place the outputs of the corresponding 10-bit latch in either a normal logic state (high or low logic levels) or a high-impedance state. In the high-impedance state, the outputs neither load nor drive the bus lines significantly.

The outputs, which are designed to sink up to 12 mA, include equivalent 25- Ω series resistors to reduce overshoot and undershoot.

These devices are fully specified for hot-insertion applications using I_{off} and power-up 3-state. The I_{off} circuitry disables the outputs, preventing damaging current backflow through the devices when they are powered down. The power-up 3-state circuitry places the outputs in the high-impedance state during power up and power down, which prevents driver conflict.

To ensure the high-impedance state during power up or power down, \overline{OE} shall be tied to V_{CC} through a pullup resistor; the minimum value of the resistor is determined by the current-sinking capability of the driver.

\overline{OE} does not affect the internal operation of the latches. Old data can be retained or new data can be entered while the outputs are in the high-impedance state.

FUNCTION TABLE
(each 10-bit latch)

INPUTS			OUTPUT
\overline{OE}	LE	D	Q
L	H	H	H
L	H	L	L
L	L	X	Q_0
H	X	X	Z

SN54ABT162841, SN74ABT162841 20-BIT BUS-INTERFACE D-TYPE LATCHES WITH 3-STATE OUTPUTS

SCBS665C – JUNE 1996 – REVISED JUNE 2004

logic diagram (positive logic)

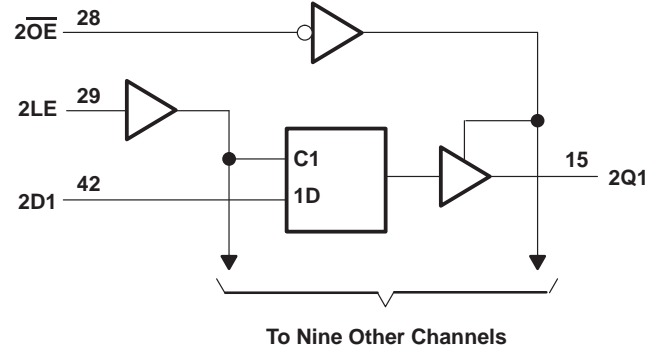
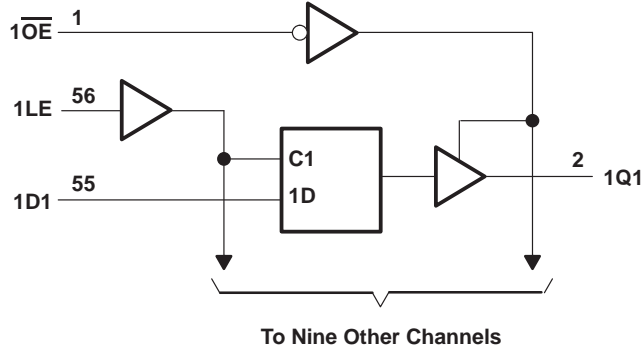

absolute maximum ratings over operating free-air temperature range (unless otherwise noted)†

Supply voltage range, V_{CC}	–0.5 V to 7 V
Input voltage range, V_I (see Note 1)	–0.5 V to 7 V
Voltage range applied to any output in the high or power-off state, V_O	–0.5 V to 5.5 V
Current into any output in the low state, I_O	30 mA
Input clamp current, I_{IK} ($V_I < 0$)	–18 mA
Output clamp current, I_{OK} ($V_O < 0$)	–50 mA
Package thermal impedance, θ_{JA} (see Note 2): DGG package	64°C/W
DL package	56°C/W
Storage temperature range, T_{stg}	–65°C to 150°C

† Stresses beyond those listed under “absolute maximum ratings” may cause permanent damage to the device. These are stress ratings only, and functional operation of the device at these or any other conditions beyond those indicated under “recommended operating conditions” is not implied. Exposure to absolute-maximum-rated conditions for extended periods may affect device reliability.

- NOTES: 1. The input and output negative-voltage ratings may be exceeded if the input and output clamp-current ratings are observed.
2. The package thermal impedance is calculated in accordance with JESD 51-7.

recommended operating conditions (see Note 3)

		SN54ABT162841		SN74ABT162841		UNIT
		MIN	MAX	MIN	MAX	
V_{CC}	Supply voltage	4.5	5.5	4.5	5.5	V
V_{IH}	High-level input voltage	2		2		V
V_{IL}	Low-level input voltage		0.8		0.8	V
V_I	Input voltage	0	V_{CC}	0	V_{CC}	V
I_{OH}	High-level output current		–3		–12	mA
I_{OL}	Low-level output current		8		12	mA
$\Delta t/\Delta v$	Input transition rise or fall rate	Outputs enabled		10	10	ns/V
$\Delta t/\Delta V_{CC}$	Power-up ramp rate	200		200		μ s/V
T_A	Operating free-air temperature	–55	125	–40	85	°C

NOTE 3: All unused inputs of the device must be held at V_{CC} or GND to ensure proper device operation. Refer to the TI application report, *Implications of Slow or Floating CMOS Inputs*, literature number SCBA004.

PRODUCT PREVIEW information concerns products in the formative or design phase of development. Characteristic data and other specifications are design goals. Texas Instruments reserves the right to change or discontinue these products without notice.



POST OFFICE BOX 655303 • DALLAS, TEXAS 75265

SN54ABT162841, SN74ABT162841

20-BIT BUS-INTERFACE D-TYPE LATCHES

WITH 3-STATE OUTPUTS

SCBS665C – JUNE 1996 – REVISED JUNE 2004

electrical characteristics over recommended operating free-air temperature range (unless otherwise noted)

PARAMETER	TEST CONDITIONS	T _A = 25°C			SN54ABT162841		SN74ABT162841		UNIT	
		MIN	TYP†	MAX	MIN	MAX	MIN	MAX		
V _{IK}	V _{CC} = 4.5 V, I _I = -18 mA			-1.2		-1.2		-1.2	V	
V _{OH}	V _{CC} = 4.5 V, I _{OH} = -1 mA			2.5		2.5		2.5	V	
	V _{CC} = 5 V, I _{OH} = -1 mA			3		3		3		
	V _{CC} = 4.5 V	I _{OH} = -3 mA			2.4		2.4			2.4
I _{OH} = -12 mA				2*				2		
V _{OL}	V _{CC} = 4.5 V	I _{OL} = 8 mA			0.4		0.8	0.65	V	
		I _{OL} = 12 mA			0.8*			0.8		
V _{hys}				100					mV	
I _I	V _{CC} = 0 to 5.5 V, V _I = V _{CC} or GND			±1		±1		±1	µA	
I _{OZPU}	V _{CC} = 0 to 2.1 V, V _O = 0.5 V to 2.7 V, $\overline{OE} = X$			±50		±50		±50	µA	
I _{OZPD}	V _{CC} = 2.1 V to 0, V _O = 0.5 V to 2.7 V, $\overline{OE} = X$			±50		±50		±50	µA	
I _{OZH}	V _{CC} = 2.1 V to 5.5 V, V _O = 2.7 V, $\overline{OE} \geq 2$ V			10		10		10	µA	
I _{OZL}	V _{CC} = 2.1 V to 5.5 V, V _O = 0.5 V, $\overline{OE} \geq 2$ V			-10		-10		-10	µA	
I _{off}	V _{CC} = 0, V _I or V _O ≤ 4.5 V			±100				±100	µA	
I _{CEX}	Outputs high	V _{CC} = 5.5 V, V _O = 5.5 V			50			50	µA	
I _{O‡}		V _{CC} = 5.5 V, V _O = 2.5 V	-25	-75	-100	-25	-100	-25	-100	mA
I _{CC}	Outputs high	V _{CC} = 5.5 V, I _O = 0, V _I = V _{CC} or GND			0.5		0.5	0.5	mA	
	Outputs low				89		89	89		
	Outputs disabled				0.5		0.5	0.5		
ΔI _{CC} §		V _{CC} = 5.5 V, One input at 3.4 V, Other inputs at V _{CC} or GND			1.5		1.5	1.5	mA	
C _i		V _I = 2.5 V or 0.5 V			3.5				pF	
C _o		V _O = 2.5 V or 0.5 V			9				pF	

* On products compliant to MIL-PRF-38535, this parameter does not apply.

† All typical values are at V_{CC} = 5 V.

‡ Not more than one output should be tested at a time, and the duration of the test should not exceed one second.

§ This is the increase in supply current for each input that is at the specified TTL voltage level, rather than V_{CC} or GND.

timing requirements over recommended ranges of supply voltage and operating free-air temperature (unless otherwise noted) (see Figure 1)

		V _{CC} = 5 V, T _A = 25°C		SN54ABT162841		SN74ABT162841		UNIT
		MIN	MAX	MIN	MAX	MIN	MAX	
t _w	Pulse duration, LE high or low	4		4		4		ns
t _{su}	Setup time, data before LE↓	0.8		0.8		0.8		ns
t _h	Hold time, data after LE↓	1.8		1.8		1.8		ns

PRODUCT PREVIEW information concerns products in the formative or design phase of development. Characteristic data and other specifications are design goals. Texas Instruments reserves the right to change or discontinue these products without notice.



SN54ABT162841, SN74ABT162841
20-BIT BUS-INTERFACE D-TYPE LATCHES
WITH 3-STATE OUTPUTS

SCBS665C – JUNE 1996 – REVISED JUNE 2004

switching characteristics over recommended ranges of supply voltage and operating free-air temperature, $C_L = 50$ pF (unless otherwise noted) (see Figure 1)

PARAMETER	FROM (INPUT)	TO (OUTPUT)	$V_{CC} = 5$ V, $T_A = 25^\circ$ C			SN54ABT162841		SN74ABT162841		UNIT
			MIN	TYP	MAX	MIN	MAX	MIN	MAX	
t _{PLH}	D	Q	2.1	3.5	4.5	2.1	5.7	2.1	5.2	ns
t _{PHL}			3	4.3	5.3	3	6.2	3	6	
t _{PLH}	LE	Q	2.1	3.5	4.5	2.1	5.6	2.1	5.4	ns
t _{PHL}			2.8	4.1	5.1	2.8	6.1	2.8	5.8	
t _{PZH}	\overline{OE}	Q	2	3.6	4.7	2	5.8	2	5.7	ns
t _{PZL}			3	4.6	5.7	3	6.7	3	6.5	
t _{PHZ}	\overline{OE}	Q	2.6	4.3	5.7	2.6	6.6	2.6	6.5	ns
t _{PLZ}			2.2	3.6	5.8	2.2	8.4	2.2	7.1	

SN54ABT162841, SN74ABT162841
20-BIT BUS-INTERFACE D-TYPE LATCHES
WITH 3-STATE OUTPUTS

SCBS665C – JUNE 1996 – REVISED JUNE 2004

PARAMETER MEASUREMENT INFORMATION

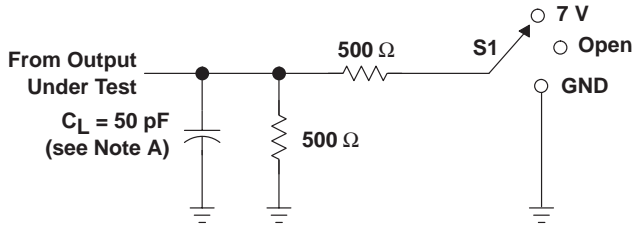

LOAD CIRCUIT

TEST	S1
t_{PLH}/t_{PHL}	Open
t_{PLZ}/t_{PZL}	7 V
t_{PHZ}/t_{PZH}	Open

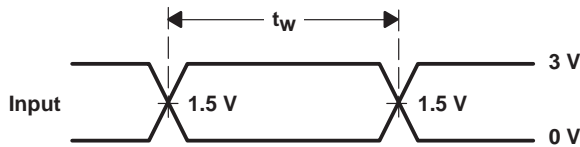

**VOLTAGE WAVEFORMS
 PULSE DURATION**

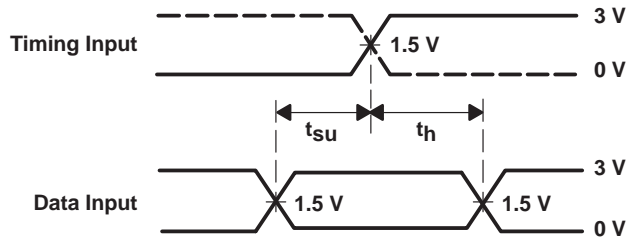

**VOLTAGE WAVEFORMS
 SETUP AND HOLD TIMES**

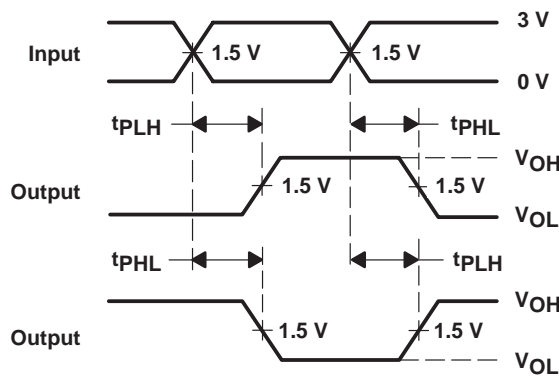

**VOLTAGE WAVEFORMS
 PROPAGATION DELAY TIMES
 INVERTING AND NONINVERTING OUTPUTS**

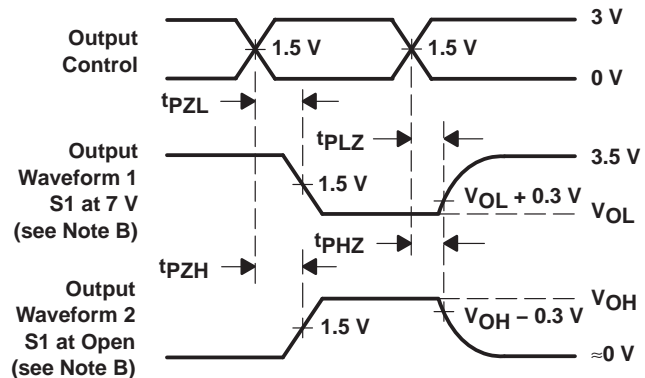

**VOLTAGE WAVEFORMS
 ENABLE AND DISABLE TIMES
 LOW- AND HIGH-LEVEL ENABLING**

- NOTES: A. C_L includes probe and jig capacitance.
 B. Waveform 1 is for an output with internal conditions such that the output is low, except when disabled by the output control. Waveform 2 is for an output with internal conditions such that the output is high, except when disabled by the output control.
 C. All input pulses are supplied by generators having the following characteristics: $PRR \leq 10 \text{ MHz}$, $Z_O = 50 \Omega$, $t_r \leq 2.5 \text{ ns}$, $t_f \leq 2.5 \text{ ns}$.
 D. The outputs are measured one at a time, with one transition per measurement.
 E. All parameters and waveforms are not applicable to all devices.

Figure 1. Load Circuit and Voltage Waveforms

PACKAGING INFORMATION

Orderable Device	Status (1)	Package Type	Package Drawing	Pins	Package Qty	Eco Plan (2)	Lead finish/ Ball material (6)	MSL Peak Temp (3)	Op Temp (°C)	Device Marking (4/5)	Samples
SN74ABT162841DGGR	ACTIVE	TSSOP	DGG	56	2000	RoHS & Green	NIPDAU	Level-1-260C-UNLIM	-40 to 85	ABT162841	Samples
SN74ABT162841DL	ACTIVE	SSOP	DL	56	20	RoHS & Green	NIPDAU	Level-1-260C-UNLIM	-40 to 85	ABT162841	Samples
SN74ABT162841DLR	ACTIVE	SSOP	DL	56	1000	RoHS & Green	NIPDAU	Level-1-260C-UNLIM	-40 to 85	ABT162841	Samples

(1) The marketing status values are defined as follows:

ACTIVE: Product device recommended for new designs.

LIFEBUY: TI has announced that the device will be discontinued, and a lifetime-buy period is in effect.

NRND: Not recommended for new designs. Device is in production to support existing customers, but TI does not recommend using this part in a new design.

PREVIEW: Device has been announced but is not in production. Samples may or may not be available.

OBSELETE: TI has discontinued the production of the device.

(2) **RoHS:** TI defines "RoHS" to mean semiconductor products that are compliant with the current EU RoHS requirements for all 10 RoHS substances, including the requirement that RoHS substance do not exceed 0.1% by weight in homogeneous materials. Where designed to be soldered at high temperatures, "RoHS" products are suitable for use in specified lead-free processes. TI may reference these types of products as "Pb-Free".

RoHS Exempt: TI defines "RoHS Exempt" to mean products that contain lead but are compliant with EU RoHS pursuant to a specific EU RoHS exemption.

Green: TI defines "Green" to mean the content of Chlorine (Cl) and Bromine (Br) based flame retardants meet JS709B low halogen requirements of <=1000ppm threshold. Antimony trioxide based flame retardants must also meet the <=1000ppm threshold requirement.

(3) MSL, Peak Temp. - The Moisture Sensitivity Level rating according to the JEDEC industry standard classifications, and peak solder temperature.

(4) There may be additional marking, which relates to the logo, the lot trace code information, or the environmental category on the device.

(5) Multiple Device Markings will be inside parentheses. Only one Device Marking contained in parentheses and separated by a "~" will appear on a device. If a line is indented then it is a continuation of the previous line and the two combined represent the entire Device Marking for that device.

(6) Lead finish/Ball material - Orderable Devices may have multiple material finish options. Finish options are separated by a vertical ruled line. Lead finish/Ball material values may wrap to two lines if the finish value exceeds the maximum column width.

Important Information and Disclaimer:The information provided on this page represents TI's knowledge and belief as of the date that it is provided. TI bases its knowledge and belief on information provided by third parties, and makes no representation or warranty as to the accuracy of such information. Efforts are underway to better integrate information from third parties. TI has taken and continues to take reasonable steps to provide representative and accurate information but may not have conducted destructive testing or chemical analysis on incoming materials and chemicals. TI and TI suppliers consider certain information to be proprietary, and thus CAS numbers and other limited information may not be available for release.

In no event shall TI's liability arising out of such information exceed the total purchase price of the TI part(s) at issue in this document sold by TI to Customer on an annual basis.

TAPE AND REEL INFORMATION

QUADRANT ASSIGNMENTS FOR PIN 1 ORIENTATION IN TAPE

*All dimensions are nominal

Device	Package Type	Package Drawing	Pins	SPQ	Reel Diameter (mm)	Reel Width W1 (mm)	A0 (mm)	B0 (mm)	K0 (mm)	P1 (mm)	W (mm)	Pin1 Quadrant
SN74ABT162841DGGR	TSSOP	DGG	56	2000	330.0	24.4	8.6	15.6	1.8	12.0	24.0	Q1
SN74ABT162841DLR	SSOP	DL	56	1000	330.0	32.4	11.35	18.67	3.1	16.0	32.0	Q1

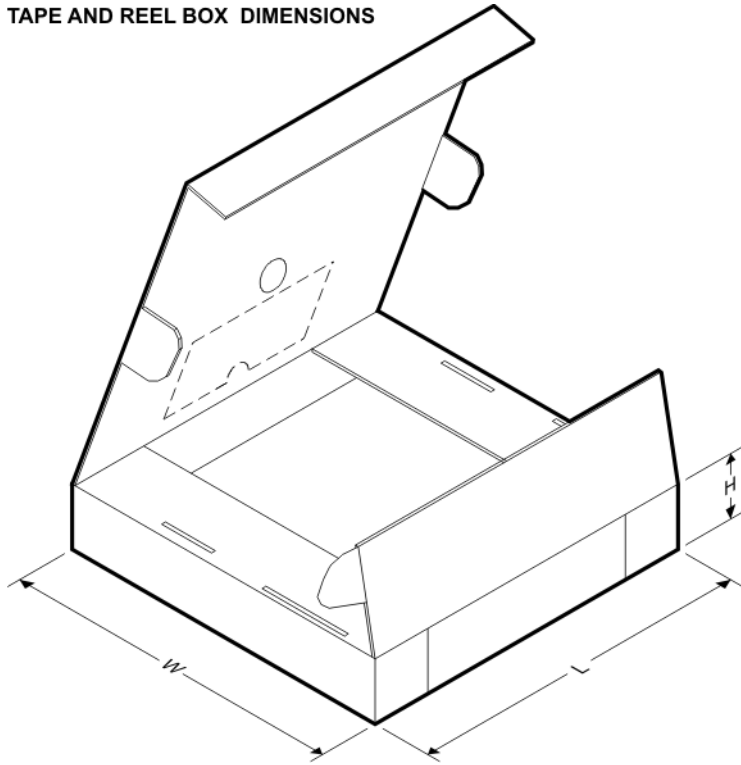
TAPE AND REEL BOX DIMENSIONS

*All dimensions are nominal

Device	Package Type	Package Drawing	Pins	SPQ	Length (mm)	Width (mm)	Height (mm)
SN74ABT162841DGGR	TSSOP	DGG	56	2000	367.0	367.0	45.0
SN74ABT162841DLR	SSOP	DL	56	1000	367.0	367.0	55.0

TUBE

*All dimensions are nominal

Device	Package Name	Package Type	Pins	SPQ	L (mm)	W (mm)	T (μm)	B (mm)
SN74ABT162841DL	DL	SSOP	56	20	473.7	14.24	5110	7.87

MECHANICAL DATA

DL (R-PDSO-G56)

PLASTIC SMALL-OUTLINE PACKAGE



- NOTES:
- A. All linear dimensions are in inches (millimeters).
 - B. This drawing is subject to change without notice.
 - C. Body dimensions do not include mold flash or protrusion not to exceed 0.006 (0,15).
 - D. Falls within JEDEC MO-118

PowerPAD is a trademark of Texas Instruments.

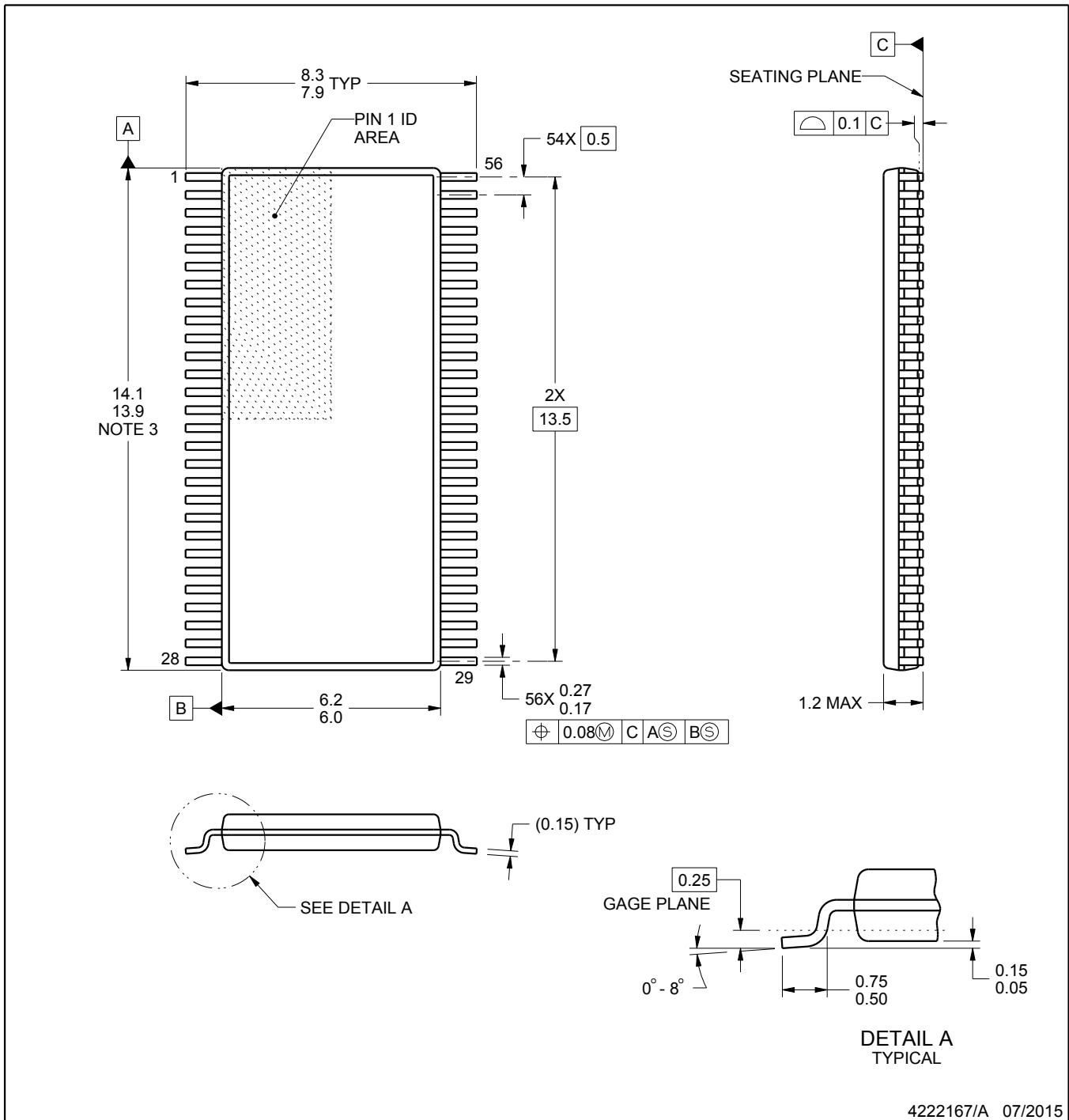

4222167/A 07/2015

NOTES:

1. All linear dimensions are in millimeters. Any dimensions in parenthesis are for reference only. Dimensioning and tolerancing per ASME Y14.5M.
2. This drawing is subject to change without notice.
3. This dimension does not include mold flash, protrusions, or gate burrs. Mold flash, protrusions, or gate burrs shall not exceed 0.15 mm per side.
4. Reference JEDEC registration MO-153.

EXAMPLE BOARD LAYOUT

DGG0056A

TSSOP - 1.2 mm max height

SMALL OUTLINE PACKAGE

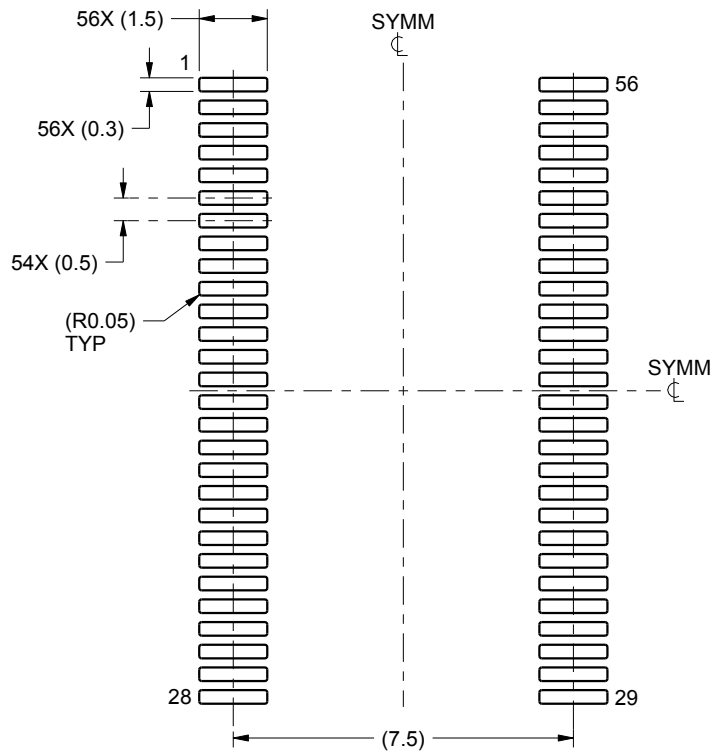

LAND PATTERN EXAMPLE
SCALE:6X

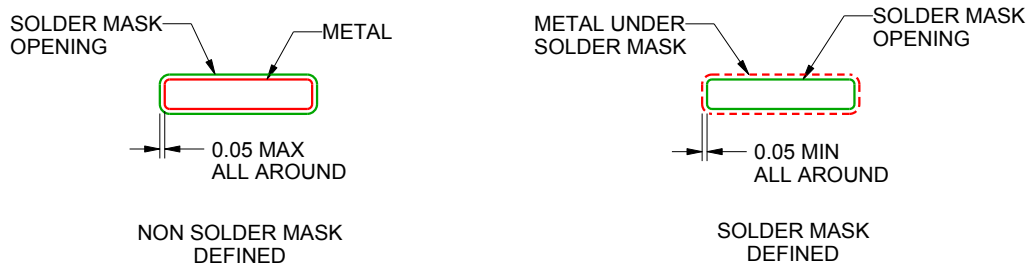

SOLDER MASK DETAILS

4222167/A 07/2015

NOTES: (continued)

- 5. Publication IPC-7351 may have alternate designs.
- 6. Solder mask tolerances between and around signal pads can vary based on board fabrication site.

EXAMPLE STENCIL DESIGN

DGG0056A

TSSOP - 1.2 mm max height

SMALL OUTLINE PACKAGE



SOLDER PASTE EXAMPLE
BASED ON 0.125 mm THICK STENCIL
SCALE:6X

4222167/A 07/2015

NOTES: (continued)

7. Laser cutting apertures with trapezoidal walls and rounded corners may offer better paste release. IPC-7525 may have alternate design recommendations.
8. Board assembly site may have different recommendations for stencil design.

IMPORTANT NOTICE AND DISCLAIMER

TI PROVIDES TECHNICAL AND RELIABILITY DATA (INCLUDING DATA SHEETS), DESIGN RESOURCES (INCLUDING REFERENCE DESIGNS), APPLICATION OR OTHER DESIGN ADVICE, WEB TOOLS, SAFETY INFORMATION, AND OTHER RESOURCES "AS IS" AND WITH ALL FAULTS, AND DISCLAIMS ALL WARRANTIES, EXPRESS AND IMPLIED, INCLUDING WITHOUT LIMITATION ANY IMPLIED WARRANTIES OF MERCHANTABILITY, FITNESS FOR A PARTICULAR PURPOSE OR NON-INFRINGEMENT OF THIRD PARTY INTELLECTUAL PROPERTY RIGHTS.

These resources are intended for skilled developers designing with TI products. You are solely responsible for (1) selecting the appropriate TI products for your application, (2) designing, validating and testing your application, and (3) ensuring your application meets applicable standards, and any other safety, security, regulatory or other requirements.

These resources are subject to change without notice. TI grants you permission to use these resources only for development of an application that uses the TI products described in the resource. Other reproduction and display of these resources is prohibited. No license is granted to any other TI intellectual property right or to any third party intellectual property right. TI disclaims responsibility for, and you will fully indemnify TI and its representatives against, any claims, damages, costs, losses, and liabilities arising out of your use of these resources.

TI's products are provided subject to [TI's Terms of Sale](#) or other applicable terms available either on ti.com or provided in conjunction with such TI products. TI's provision of these resources does not expand or otherwise alter TI's applicable warranties or warranty disclaimers for TI products.

TI objects to and rejects any additional or different terms you may have proposed.

Mailing Address: Texas Instruments, Post Office Box 655303, Dallas, Texas 75265
Copyright © 2022, Texas Instruments Incorporated

Looking for pricing, stock, or lifecycle information?

Click below to explore more details on WIN SOURCE:

- ⊖ [View SK-AX2-CG624-KITBTM on WIN SOURCE](#)
- ⊖ [Microchip Technology](#) Information

Optimize Your Supply Chain with WIN SOURCE Solutions

- ✓ Global Sourcing Solution
- ✓ Obsolete Management
- ✓ Cost Control Management
- ✓ Shortage Management
- ✓ Alternative Solution
- ✓ Excess Inventory Management