



**THE DATASHEET OF
SW-314-TB**



M/A-COM GaAs SP4T Absorptive Switch, DC - 3 GHz

V 5

SW-314

Features

- Integral TTL Driver
- Isolation: 50 dB Typ. At 1 GHz
- Ultra Low DC Power Consumption
- Hermetic Surface Mount Package
- 50 Ohms Nominal Impedance
- MIL-STD-883 Screening Available

Description

M/A-COM's SW-314 is a GaAs MMIC SP4T absorptive switch with an integral silicon ASIC driver. This device is in a 24-lead ceramic surface mount package. These switches exhibit excellent performance from DC to 3 GHz, with very low DC power dissipation. The SW-314 is ideally suited for RF/IF communications applications. Environmental screening is available. Contact the factory for information.

Ordering Information

Part Number	Package
SW-314	CR-14
SW-314-TB	Unit Mounted on Test Board

Truth Table

TTL Control Inputs				Condition of Switch			
C1	C2	C3	C4	RF Common to Each RF Port			
				RF1	RF2	RF3	RF4
1	0	0	0	On	Off	Off	Off
0	1	0	0	Off	On	Off	Off
0	0	1	0	Off	Off	On	Off
0	0	0	1	Off	Off	Off	On

0 = TTL Low 1 = TTL High

Functional Schematic

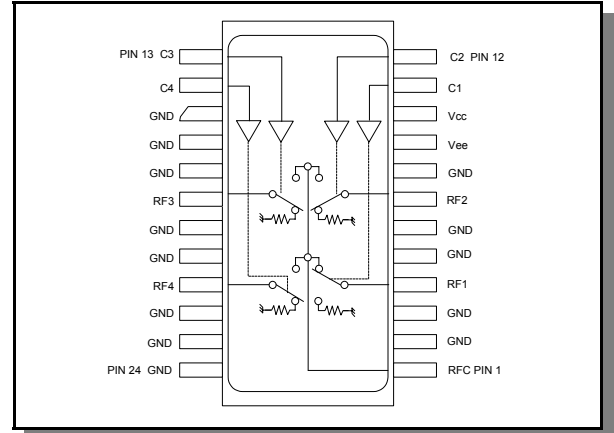

Absolute Maximum Ratings ^{1,2}

Parameter	Absolute Maximum
Max Input Power 0.05 GHz 0.5 - 3.0 GHz ²	+27 dBm +34 dBm
Bias Voltages Vcc Vee	-0.5 to +5.5V -8.5V to +0.5V
Control Voltage ³	-0.5V, to Vcc +0.5V
Operating Temperature	-55°C to +125°C
Storage Temperature	-65°C to +150°C

1. Operation of this device above any one of these parameters may cause permanent damage.
2. When the input power is applied to the terminated port, the absolute maximum is +30 dBm.
3. Standard CMOS TTL interface, latch-up will occur if logic signal is applied prior to power supply.

M/A-COM Inc. and its affiliates reserve the right to make changes to the product(s) or information contained herein without notice.

Visit www.macom.com for additional data sheets and product information.

- North America: Tel. (800) 366-2266
- Asia/Pacific: Tel. +81-44-844-8296, Fax +81-44-844-8298
- Europe: Tel. +44 (1908) 574200, Fax +44 (1908) 574300

tyco / Electronics

M/A-COM

Electrical Specifications^{4,5} (From -55°C to +85°C)

Parameter	Test Conditions	Frequency	Units	Min	Typ	Max
Insertion Loss	—	DC - 0.5 GHz	dB	—	—	1.3
		DC - 1.0 GHz	dB	—	—	1.4
		DC - 2.0 GHz	dB	—	—	1.6
		DC - 3.0 GHz	dB	—	—	1.8
Isolation	—	DC - 0.5 GHz	dB	50	—	—
		DC - 1.0 GHz	dB	40	—	—
		DC - 2.0 GHz	dB	35	—	—
		DC - 3.0 GHz	dB	30	—	—
VSWR	RFC, RF1 - RF4 (On)	DC - 0.5 GHz	Ratio	—	—	1.6:1
		DC - 1.0 GHz	Ratio	—	—	1.6:1
		DC - 2.0 GHz	Ratio	—	—	1.6:1
		DC - 3.0 GHz	Ratio	—	—	1.8:1
VSWR	RF1 - RF4 (Off)	DC - 0.5 GHz	Ratio	—	—	1.3:1
		DC - 1.0 GHz	Ratio	—	—	1.5:1
		DC - 2.0 GHz	Ratio	—	—	1.9:1
		DC - 3.0 GHz	Ratio	—	—	2.4:1
Trise, Tfall	10% to 90%	—	ns	—	7	—
Ton, Toff	50% Control to 90% / 10% RF	—	ns	—	25	—
Transients	In-Band (peak-peak)	—	mV	—	20	—
1 dB Compression	Input Power	0.05 GHz	dBm	—	+20	—
		0.5 GHz to 3 GHz	dBm	—	+27	—
IP3	Two-Tone Input Power up to +5 dBm	0.05 GHz	dBm	—	+35	—
		0.5 GHz to 3 GHz	dBm	—	+46	—
IP2	Two-Tone Input Power up to +5 dBm	0.05 GHz	dBm	—	+45	—
		0.5 GHz to 3 GHz	dBm	—	+60	—
Vcc	—	—	V	4.5	5.0	5.5
Vee	—	—	V	-8.0	—	-5.0
Icc	Vcc = 4.5 to 5.5 V Vctl = 0 to 0.8V, or Vcc -2.1V to Vcc	—	mA	—	0.2	4.0
Iee	Vee = -5.0V to -8.0V	—	mA	—	0.1	1.0
Vctl Vcti	Logic 0 (TTL)	—	V	0.0	—	0.8
	Logic 1 (TTL)	—	V	2.0	—	5.0
Input Leakage Current (Low)	0 to 0.8V	—	µA	—	—	1.0
Input Leakage Current (High)	2.0 to 5.0V	—	µA	—	—	1.0

4. All specifications apply when operated with bias voltages of +5V for Vcc and -5V for Vee.

5. When DC blocks are used, a 10K ohm return to GND is required on the RFC port.

M/A-COM Inc. and its affiliates reserve the right to make changes to the product(s) or information contained herein without notice.

Visit www.macom.com for additional data sheets and product information.

■ North America: Tel. (800) 366-2266

■ Asia/Pacific: Tel. +81-44-844-8296, Fax +81-44-844-8298

■ Europe: Tel. +44 (1908) 574200, Fax+44 (1908) 574300

tyco / Electronics

M/A-COM

Typical Performance Curves

Insertion Loss vs. Frequency

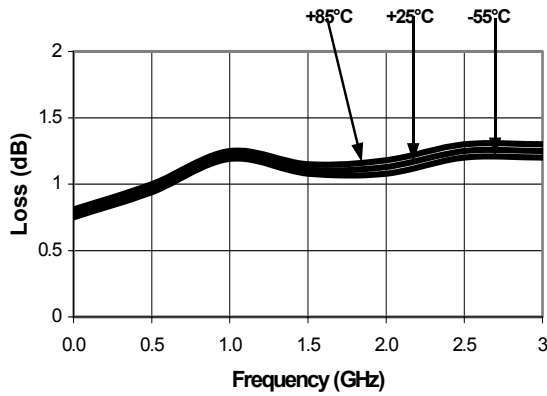

Isolation vs. Frequency

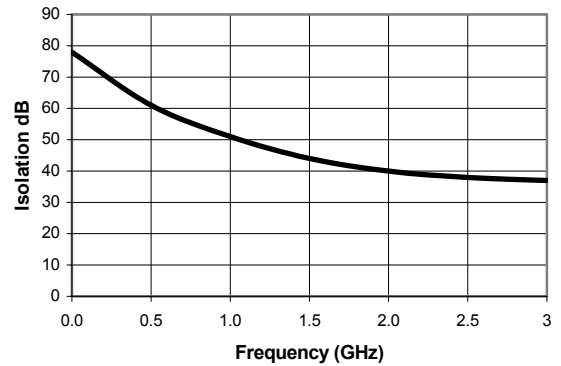

VSWR vs. Frequency

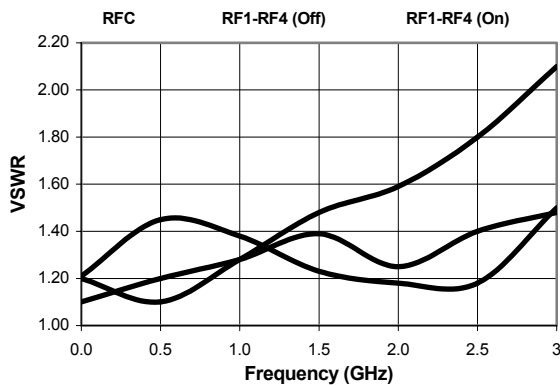

CR-14

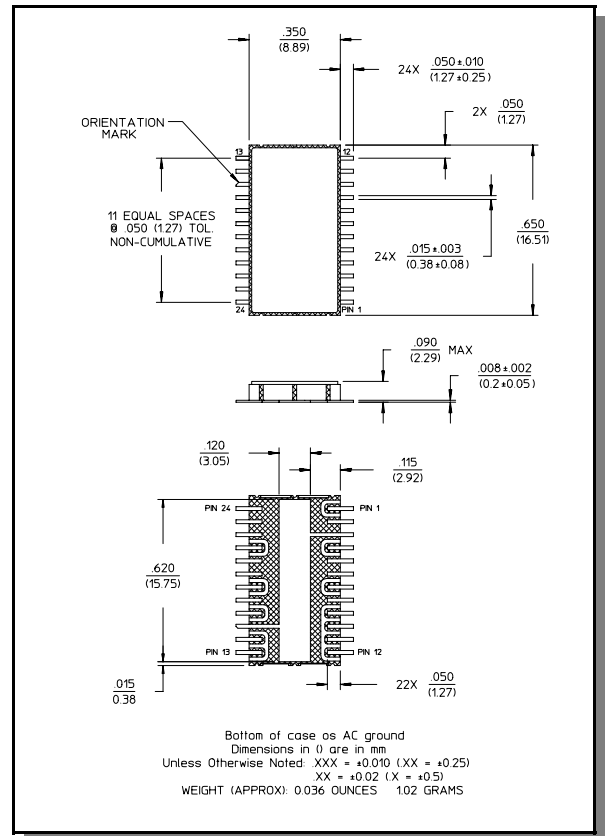

M/A-COM Inc. and its affiliates reserve the right to make changes to the product(s) or information contained herein without notice.

Visit www.macom.com for additional data sheets and product information.

- North America: Tel. (800) 366-2266
- Asia/Pacific: Tel. +81-44-844-8296, Fax +81-44-844-8298
- Europe: Tel. +44 (1908) 574200, Fax+44 (1908) 574300

Looking for pricing, stock, or lifecycle information?

Click below to explore more details on WIN SOURCE:

- ⊖ [View SW-314-TB on WIN SOURCE](#)
- ⊖ [M/A-Com Technology Solutions Information](#)

Optimize Your Supply Chain with WIN SOURCE Solutions

- ✓ Global Sourcing Solution
- ✓ Obsolete Management
- ✓ Cost Control Management
- ✓ Shortage Management
- ✓ Alternative Solution
- ✓ Excess Inventory Management